

Colección Estudios, 5



TELL EL-GHABA I

**A Saite Settlement in North Sinai, Egypt
(Argentine Archaeological Mission, 1995-2004)**

**Edited by Perla Fuscaldo
Editorial Assistance: Silvia Lupo**

Introduction

Catalogue

Introduction to the Catalogue

Stratigraphy and Archaeological Material recovered from Tell el-Ghaba

Part I: Area I

Part II: Area II

Part III: Area VI

**Consejo Nacional de Investigaciones Científicas y Técnicas
Instituto Multidisciplinario de Historia y Ciencias Humanas
Departamento de Egiptología
Saavedra 15, 5º, Buenos Aires (C1083), Argentina
Buenos Aires
2005**

CONICET

Tell el-Ghaba I : A saite settlement in north sinai, Egypt (Argentine Archaeological Mission, 1995-2004). Introduction. Catalog. . - 1a ed. - Buenos Aires : Consejo Nacional Investigaciones Científicas Técnicas - CONICET. Instituto Multidisciplinario de Historia y Ciencias Humanas - IMHICIHU. , 2011. Internet. - (Tell el-Ghaba)

ISBN 978-950-692-096-8

**1. Arqueología. I. Título.
CDD 930.1**

**Consejo Nacional de Investigaciones Científicas y Técnicas
(CONICET)**

**Instituto Multidisciplinario de Historia y Ciencias Humanas
(IMHICIHU)**

Director: Dr. Ariel Guance

Vice-Director: Dr. Luis Borrero

Address: Saavedra 15, 5th floor (C1083 ACA) Buenos Aires, Argentina

Phone/fax: (00-54-11) 4953-8548, 2042

e-mail: imhicihu@conicet.gov.ar

Departamento de Egiptología (DEGIP)

Chairman: Dr. Alicia Daneri de Rodrigo

e-mail: degip.imhicihu@conicet.gov.ar

Colección Estudios: Publication of projects developed at the DEGIP

Project No. I: "Sinai"

Director: Dr. Perla Fuscaldo

e-mail: perla.fuscaldo@fibertel.com.ar

Grants for publication

1.- *The Agencia Nacional de Promoción Científica y Tecnológica (ANPyCT-Buenos Aires) through the Fondo para la Investigación Científica y Tecnológica (FONCyT), in the frame of the Programa de Modernización Tecnológica, Contrato de Préstamo BID 802/OC-AR*, for the project: *PICT' 2000, No. 04-08867, "Tell el-Ghaba, Egipto: Excavaciones de rescate y análisis de laboratorio de un sitio saíta en el Delta Oriental"*, 2002-2003, under the direction of Perla Fuscaldo.

2.- CONICET, IMHICIHU.

ISSN: 1850-3462

ISBN-10: 950-692-073-7

ISBN-13: 978-950-692-073-9

Tell el-Ghaba I

Contents

Introduction by Perla Fuscaldo

The Argentine Archaeological Mission at Tell el-Ghaba	8
The site	8
Calendar of fieldwork and study seasons in Egypt (1995-2002)	10
Financial support	15
Acknowledgements	16
Reports prior to this publication.....	18
List of Maps	21

Catalogue

by Perla Fuscaldo, Eduardo Crivelli Montero, Silvia Lupo, Susana Basílico,
Beatriz Cremonte, Claudia Kohen, Cristina Bacquerisse (together with Adriana Chauvin,
Silvana Fantechi, María Violeta Pereyra de Fianza and Ana María Rosso)

Introduction to the Catalogue

I.- Catalogue	23
II.- Methodology	23
a) Methods of excavation, by Eduardo Crivelli Montero	
b) Methods of lab recording. Pottery recording, by Perla Fuscaldo, Silvia Lupo . and Susana Basílico	
III.- On the archaeological material from the Catalogue, by Perla Fuscaldo	25
List of Abbreviations used in the Catalogue	27
List of Plans, Plates, Graphics and Sections	29
Egyptian chronology	31
Tables I and II: Description of local and non-local fabrics	32
Bibliography	37
Abbreviations used in the Bibliography	48

Stratigraphy and Archaeological Material recovered from Tell el-Ghaba,

by Eduardo Crivelli Montero and Perla Fuscaldo

Part I: Area I

Abstract	50
Level I: Strata below Building A and Structure G	50
1.- Stratigraphy	
2.- Archaeological material: L0371 (Fig.1), L0372	
Level II: Building A and Structure G	53
Building A (Plan II)	
1.- General description	

2.- Archaeological material: L0035 (Fig. 2), L0040 = L0043 = L0044 (Fig. 3), L0050 = L0052 (Fig. 4), L0101 = L0266 (Fig. 5), L0290 = L0346, L0316 (Fig. 6), L0319 = L0211 (Fig. 7), L0345 (Fig. 8), L0352 (Fig. 9), L0353 (Fig. 10), L0356 (Fig. 11).

Structure G (Plan II)

1.- Description

2.- Archaeological material, L0273 (Fig. 12)

Level III: L0289 80

1.- Description

2.- Archaeological material (Fig. 13)

Level IV: Building B 84

1.- General description (Plan III)

2.- Archaeological material: L0012 = L0209 (Fig. 14), L0014 = L0059 = L0081 (Fig. 15), L0015 = L0023 (Fig. 16), L0016 = L0183 (Fig. 17), L0017 (Fig. 18), L0029 (Fig. 19), L0038 (Fig. 20), L0047 (Fig. 21), L0069 (Fig. 22), L0084 (Fig. 23), L0169 (Fig. 24), L0176 (Fig. 25), L0179 (Fig. 26), L0263 = L0222 (Fig. 27), L0237 (Fig. 28), L0250 = L0175 = L280 (Fig. 29), L0271 = L0283 = L0060 (Fig. 30), L0294 (Fig. 31).

Level V: Workshops in southern Area I (Plan IV)..... 130

1.- Stratigraphy

2.- Archaeological material: L0007 (Fig. 32), L0013, L0067 (Fig. 33), L0185 (Fig. 34), L0186, L0202 (Fig. 35), L0206 (Fig. 36), L0244 (Fig. 37), L0274 (Fig. 38), L0314 (Fig. 39).

Level VI: Conflagration and abandonment (L0001)..... 144

1.- Description

2.-Archaeological material (Fig. 40)

List of Figures and Plates of the recovered material from Area I by loci..... 201

Plates of the recovered material from Area I by loci..... 202

Part II: Area II

Abstract 203

Area II, East section

Level I: Strata below Building L 203

1.- Stratigraphic sequence

2.- Archaeological material: L1231 (Fig. 1), L1233 (Fig. 2), L1234 (Fig. 3), L1235 (Fig. 4), L1408 (Fig. 5), L1409 (Fig. 6), L1410 (Fig. 7), L1413 (Fig. 8), L1419 (Fig. 9), L1420 (Fig. 10)

Level II: Building L 221

1.- General description (Plan VI)

Walls of Building L

Rooms of Building L

2.- Archaeological material: L1102 (Fig. 11), L1104 (Fig. 12), L1107 (Fig. 13), L1108, L1112 = L1102bis (Fig. 14), L1122 (Fig. 15), L1123 (Fig. 16), L1124 (Fig. 17), L1125 (Fig. 18), L1126 (Fig. 19), L1217 (Fig. 20), L1224 (Fig. 21), L1225 (Fig. 22), L1228 = L1237 (Fig. 23), L1229 (Fig. 24), L1230 (Fig. 25), L1236 (Fig. 26), L1400 (Fig. 27), L1404 (Fig. 28), L1406 (Fig. 29), L1407 (Fig. 30), L1417 (Fig. 31), L1421, L1423 (Fig. 32)

Level III: Decay of Building L and utilization of the place before the erection

of Building D 264

1.- General description

2.- Archaeological material: L1212 (Fig. 33), L1214 (Fig. 34), L1219 (Fig. 35), L1221 (Fig. 36)

Level IV: Building D 274

1.- General description (Plan V)

2.- Archaeological material: L1138 (Fig. 37)

Level V: Upper layers 275

Area II, West section. Sondages in the open spaces of Building C (L1008) (Plan V)

Abstract 275

Operation 25 275

1.- Stratigraphic sequence

2.- Archaeological material: L1001, L1008 (Fig. 38), L1010 (Fig. 39), L1014 (Fig. 40), L1016 (Fig. 41).

Operation 26 279

1.- Stratigraphic sequence

2.- Archaeological material: L1001, L1008, L1010, L1016 (Fig. 41), L1031 (Fig. 42)

Operations 32, 33, 34 and 35 281

1.- Stratigraphic sequence

2.- Archaeological material: L1001, L1008, L1024 (Fig. 43), L1025 (Fig. 44), L1038 (Fig. 45), L1039 (Fig. 46), L1043 (Fig. 47), L1054 (Fig. 48), L1060 (Fig. 49),

L1061 (Fig. 50).

Operations 36 and 41	303
1.- Stratigraphic sequence	
2.- Archaeological material: L1001, L1008, L1058 (Fig. 51), L1065 (Fig. 52), L1069 (Fig. 53), L1084 (Fig. 54), L1090 (Fig. 55), L1091, L1094 (Fig. 56), L1095 (Fig. 57)	
Some remarks concerning the operations in Area II West	319
West and East sections	
Archaeological material from the destruction layer L1001 = L1004 (Fig. 58)	319
List of Figures and Plates of the recovered material from Area II by loci	341
Plates of the recovered material from Area II by loci	343

Part III: Area VI

Abstract	345
Level I: Pre-Building F	345
1.- Stratigraphic sequence	
2.- Archaeological material: L0511 (Fig. 1), L0517 (Fig. 2), L0518 (Fig. 3), L0546 (Fig. 4), L0547 (Fig. 5), L0587 (Fig. 6), L0589 (Fig. 7), L0591 (Fig. 8)	
Level II: Building F	358
1.- General description (Plan VIII)	
2.- Archaeological material: L0503 (Fig. 9), L0516 (Fig. 10)	
Level III: Post-Building F	362
1.- Stratigraphic sequence	
2.- Archaeological material: L0507 (Fig. 11), L0508 (Fig. 12), L0512 (Fig. 13), L0519 (Fig. 14), L0522 (Fig. 15), L0551 (Fig. 16), L1001 (Fig. 17)	
List of Figures and Plates of the recovered material from Area VI by loci	377
Plates of the recovered material from Area II by loci	377

TELL EL-GHABA I

Introduction

by Perla Fuscaldo

The Argentine Archaeological Mission at Tell el-Ghaba

Between 1995 and 2002 the Argentine Archaeological Mission worked at Tell el-Ghaba, North Sinai, Egypt ([Maps I and II](#)), in the frame of the “Archaeological Salvage Project of the Monuments in North Sinai”, headed by Faiza Hekal and Mohamed Abd el-Maksoud, under UNESCO patronage.¹

The Argentine Archaeological Mission at Tell el-Ghaba was a joint project involving the former *Programa de Estudios de Egiptología* (now the Department of Egyptology, of the National Scientific Council (CONICET-Buenos Aires) and the School of Philosophy and Letters (Facultad de Filosofía y Letras), University of Buenos Aires (UBA). Declared of national interest by the Government of the Argentine Republic,² this project is currently under the patronage of the Department of Cultural Relations of the Ministry of Foreign Affairs, International Trade and Worship and the National Museum of Oriental Art (Museo Nacional de Arte Oriental).

In 1995 the Argentine Archaeological Mission at Tell el-Ghaba started to work in North Sinai, with a team of Egyptologists and Archaeologists from the National Scientific Council (CONICET) and the University of Buenos Aires. The first part of the project³ was under my direction. At present it is under the direction of Silvia Lupo, who is still working with the same team.

The site

Tell el-Ghaba ([Map I](#)) was one of the sites on the ancient “Ways of Horus”, the land bridge between the eastern Nile Delta and the Levant.⁴ It is located at 30° 58’ North and 32° 25’ East, between Tell Hebwa to the west and Tell Kedwa to the east, at the edge of the eastern part of a lagoon, near the former Pelusiac branch of the Nile ([Map II](#)). In the VII century AD, the Pelusiac branch dried out and the region became a desert. Thus, by the time we started to work at Tell el-Ghaba, this deserted region was covered with dunes and brushwood. It was an area used for pasturing camels and hunting birds ([Plates I:1 and I:2](#)).

The fieldwork done under the direction of Eduardo Crivelli⁵, and the geophysical survey carried out by Jorge Trench⁶ showed that the site had at least an extension of 12 Ha (120,000 m²), 500 m long and 250 m wide; the latter measurement would be the distance

¹ On this project, `Abd el-Maksoud, *Discussion in Egyptology* 24, 7-12.

² Decree No. 563/95.

³ For reports prior to this publication, see below.

⁴ On the survey carried out in 1990-1991 by the French Mission at Tell el-Herr for the Supreme Council of Antiquities, see Valbelle, Le Saout, Chartier-Raymond, Abd el-Samie, Traunecker, Wagner, Carrez-Maratray, Zignani, *CRIPEL* 14, 11-22, specially p.18 (Tell el-Ghaba). On the survey and excavations made between 1972-1982 by the North Sinai Expedition of the Ben-Gurion University of the Negev, under the direction of E. O. Oren, during the Israeli occupation of the region, see: Oren, in Stern, Lewinson-Gilboa and Aviram (eds.), *The New Encyclopedia of Archaeological Excavations in The Holy Land*, vol. 4, 1386-1396; Oren, *BASOR* 256 (1984), 7-44; Oren, in Rainey (ed.), *Egypt, Israel and Sinai*, 69-119. An excavation on the north part of the concession was carried out in 1992 by Nabil Sharif (SCA; see [Plan IX](#), topographic plan made by the Argentine Archaeological Mission in 1995, with the remains of mud-brick structures from Sharif excavation). I thank Eliezer Oren for allowing me to have access to the field and ceramic documentation of his survey in North Sinai; and to D. Valbelle and F. Le Saout for allowing me access to the documentation of the survey at Tell el-Ghaba, the “Report on sherds seen in North Sinai in October 1992” (by P. French and by J. Bourriau), and the pottery recovered in this survey that is stored in the French Mission House at Balouza.

⁵ See the description of the stratigraphy in “The Stratigraphy and the Archaeological Material recovered from Tell el-Ghaba” (pp.23), in the *Catalogue*, and Eduardo Crivelli Montero, “The Excavation of the Site. Methodology and Problems”, in *Tell el-Ghaba II, Studies* (forthcoming).

⁶ Jorge Trench, “The Geophysical Survey of the Site. Methodology and Results”, in *Tell el-Ghaba II, Studies* (forthcoming).

from the border of the lagoon (Plan I).⁷ The archaeological deposit is around 1.80 m deep, the sediments are salt-rich and the water table is quite high, the organic material is badly preserved, and the upper part has been swept away by erosion. Only the basement of the mud brick structures remains. The Egyptian pottery from Tell el-Ghaba corresponds to the Phase IV North,⁸ the imported one to the Iron Age IIC⁹ and Cypro-Archaic I (IV),¹⁰ which shows the connection between Egypt and the Eastern Mediterranean, especially with the Levant.¹¹

The pottery, used as the main chronological indicator, dates Tell el-Ghaba as an early Saite settlement, from the beginning of the 26th Dynasty, in the second part of the reign of Psametichus I, until the beginning of that of Psametichus II. It is probable that before the Saite expansion on the Levant, which started with the capture of the harbour of Ashdod by Psametichus I in his 29th year¹² (635 BC.), the kings of the 26th Dynasty built some forts and settlements in the “Ways of Horus” for the campaigns in Judah. Tell el-Ghaba could have been one of these sites. The large amount of Levantine amphorae found in the site points to an important land-trade with Judah and Israel, which could have increased in connection with the Egyptian expansion to the Euphrates carried out by Necho II (609-595 BC), who fought in Megiddo against Judah and was defeated by the Babylonians in Karkemish. A clay plaque¹³ with the representation of a nude female with Nubian features, could be connected with the campaign of Psametichus II against Nubia (592-590 BC) at the beginning of his reign.¹⁴

⁷ Plan of Tell el-Ghaba showing the areas excavated and surveyed by the Argentine Archaeological Mission, 1995-1999.

⁸ 650/625 - 575/550 BC, according to Aston, *Egyptian Pottery of the Late New Kingdom and Third Intermediate Period*, 92.

⁹ 700-586 BC, according to Neaehl/1993, in Herr, *BA* 60, 3, 116.

¹⁰ 750-600 BC, Sorensen, 287, note 2.

¹¹ On the pottery of the site see *Tell el-Ghaba II, Studies*, “The Pottery”, by P. Fuscaldo, S. Lupo, B. Cremonese and S. Basilico (forthcoming).

¹² Chronology of the Saite period according to Kitchen, *The Third Intermediate Period in Egypt*, 467.

¹³ Inv. No. F0179 + F0475, a “concubine”, found in L0001. On the finds from Tell el-Ghaba, see *Studies*, “The Finds”, by C. Bacquerisse (forthcoming).

¹⁴ See: *Tell el-Ghaba II, Studies*, “The Date of the Site” by P. Fuscaldo (forthcoming).

Calendar of fieldwork and study seasons in Egypt (1995-2002)

- Director of the Mission (1995-2004):
Perla Fuscaldo (Egyptologist; CONICET-UBA)
- Director of fieldwork:
Eduardo Crivelli (Archaeologist; CONICET-UBA)

First Campaign, 1995

September 12th -November 23rd

- Lab director and pottery recorder:
Perla Fuscaldo (Ph.D.; Egyptologist; CONICET-UBA)
- Vice-director of the Mission and deputy director; field assistant:
Violeta Pereyra de Fianza (M.A.; Egyptologist; CONICET-UBA)
- Field director:
Eduardo Crivelli (M.A.; Archaeologist; CONICET-UBA)
- Field supervisor
Maryla Kapica (M.A.; Archaeologist; University of Cracow, Poland)
- Field-assistant and pottery-recording team:
Silvia Lupo de Ferriol (M.A.; Egyptologist; CONICET)
Silvana Fantechi (B.A.; Egyptologist; CONICET)*
- Field-assistant and small-finds recorder:
Andrea Zingarelli (B.A.; Egyptologist; CONICET)*
- Architect
Antonio Balogh-Kovács
- Photographer:
Eduardo Crivelli
- Inspector of the SCA
Ezzat Fathy Masoued

Second Campaign, 1996

September 19th - November 19th

- Lab director and pottery recorder:
Perla Fuscaldo
- Vice-director of the Mission and deputy director:
Violeta Pereyra de Fianza
- Field director:
Eduardo Crivelli
- Field-supervisor team:
Silvana Fantechi (B.A.; Egyptologist; CONICET)*
Daniel Loponte (M.A.; Archaeologist; University of La Plata)
Violeta Pereyra de Fianza (M.A.; Egyptologist; CONICET-UBA)
Andrea Zingarelli (B.A.; Egyptologist; CONICET) *
- Field-assistant team:
Alejandro Botta (Ph. D. student; CONICET)*
Pablo Ceriani (volunteer, student UBA)
Eduardo Poli (volunteer, student UBA)

*Ad-honorem researchers in the former *Programa de Estudios de Egiptología (PREDE-CONICET)*, now the *Departamento de Egiptología (DEGIP)*, Instituto Multidisciplinario de Historia y Ciencias Humanas (IMHICIHU), CONICET, Buenos Aires. See pp.2

- Pottery recording team:
Silvia Lupo de Ferriol (M.A.; Egyptologist; CONICET)
Juliana Garrote (M.A.; Archaeologist)
Elsa Rosenvasser Feher (Ph. D.; Physicist; volunteer)
Silvia Crochetti (B.A.; volunteer, University of La Pampa)
- Small-finds recording team:
Ana María Rosso (volunteer, student UBA)
Eduardo Poli (volunteer, student UBA)
- Restorer:
Graciela Arbolave
- Fauna analysis:
Daniel Loponte
- Photographer:
Libio Pensavalle
- Inspector of the SCA and pottery recorder:
Osama R. Hamza

Third Campaign, 1997

Field work: March 11th -April 10th

- Director of the Mission:
Perla Fuscaldo
- Vice-director of the Mission and deputy director:
Violeta Pereyra de Fianza
- Field director:
Eduardo Crivelli
- Field-supervisor team:
Daniel Loponte (M.A.; Archaeologist; University of La Plata)
Violeta Pereyra de Fianza (M.A.; Egyptologist; CONICET-UBA)
Andrea Zingarelli (B.A.; Egyptologist; CONICET) *
- Field assistant and small-finds recorder:
Claudia Kohen (M.A.; Archaeologist; CONICET-UBA;)*
- Architect :
Antonio Balogh-Kovács
- Photographer:
Pablo Zubizarreta
- Inspector of the SCA:
Osama R. Hamza

Fourth Campaign, 1997

Lab work: October 31st -December 8th

- Lab director and pottery analyst:
Perla Fuscaldo
- Pottery-recording team:
Silvia Lupo (M.A.; Egyptologist; CONICET)
Eduardo Crivelli (M.A.; Archaeologist; CONICET-UBA)
Susana Basílico (M.A.; Archaeologist; UBA)*
Juliana Garrote (M.A.; Archaeologist; UBA)*
Claudia Kohen (M.A.; Archaeologist; CONICET-UBA) *

*Ad-honorem researchers in the former *Programa de Estudios de Egiptología (PREDE-CONICET)*, now the *Departamento de Egiptología (DEGIP), Instituto Multidisciplinario de Historia y Ciencias Humanas (IMHICIHU), CONICET, Buenos Aires*. See [pp.2](#)

- Adriana Chauvin (Student UBA)
- Photographer:
Eduardo Crivelli
- Inspector of the SCA:
Ramadan Helmi Mohamed

Fifth Campaign, 1998

September 26th -December 5th

- Lab director and pottery analysis:
Perla Fuscaldo
- Field director:
Eduardo Crivelli
- Geophysical survey director
Jorge Trench (Ph.D.; Physicist)
- Field-supervisor team:
Susana Basílico (M.A.; Archaeologist; CONICET-UBA)*
Silvana Fantechi (B.A.; Egyptologist; CONICET-UBA)*
Claudia Kohen (M.A.; Archaeologist; CONICET-UBA) *
Violeta Pereyra de Fianza (M.A.; Egyptologist; CONICET-UBA)
Andrea Zingarelli (B.A.; Egyptologist; CONICET-UBA)*
Adriana Chauvin (student UBA)*
- Field assistant:
Cristina Bacquerisse (B.A.; CONICET-UBA)*
- Topographer:
Marta Búcola
- Photographers:
Libio Pensavalle
Pablo Zubizarreta
- Pottery-recording team:
Silvia Lupo de Ferriol (M.A.; Egyptologist; CONICET)
Beatriz Cremonte (Ph.D.; Archaeologist; CONICET; pottery analyst)
Susana Basílico (M.A.; Archaeologist; UBA)*
Adriana Chauvin (Student UBA)
- Small-find recording team:
Ana María Rosso (volunteer, student UBA);
Cristina Bacquerisse (B.A.; CONICET-UBA; field assistant)*
- Restorer:
Graciela Arbolave
- Photographer:
Susana Basílico
- Inspectors of the SCA:
`Ahmed Rashed `Amer
Mahmaud Mansour

Sixth Campaign, 1999

September 23rd -December 5th

- Lab director and pottery analyst:
Perla Fuscaldo

*Ad-honorem researchers in the former Programa de Estudios de Egiptología (PREDE-CONICET), now the Departamento de Egiptología (DEGIP), Instituto Multidisciplinario de Historia y Ciencias Humanas (IMHICIHU), CONICET, Buenos Aires. See [pp.2](#)

- Field director and deputy director from September 27th to October 29th:
Eduardo Crivelli (Ph.D.)
- Geophysical survey director
Jorge Trench (Ph.D.; Physicist)
- Field-supervisor team:
Susana Basílico (M.A.; Archaeologist; CONICET-UBA)*
Claudia Kohen (M.A.; Archaeologist; CONICET-UBA)*
Adriana Chauvin (student UBA; CONICET-UBA)*
Leticia Martínez (M.A.; archaeologist; CONICET-UBA)*
Paola Ramundo (M.A.; archaeologist; CONICET-UBA)*
Silvina Vigliani (M.A.; archaeologist; CONICET-UBA)*
Claudia Bisso (student UBA)
- Field assistants:
Natalia Bas (student UBA)
Cristina Bacquerisse (B. A.; Egyptologist; CONICET-UBA)*
- Pottery-recording team:
Silvia Lupo (M.A.; Egyptologist; CONICET; deputy of the director from December 1st to 4th)
Beatriz Cremonte (Ph.D.; Archaeologist; CONICET; pottery analysis)
Susana Basílico (M.A.; Archaeologist; CONICET-UBA)*
Adriana Chauvin (student UBA; CONICET-UBA)*
Leticia Martínez (M.A.; archaeologist; CONICET-UBA)*
Paola Ramundo (M.A.; archaeologist; CONICET-UBA)*
Silvina Vigliani (M.A.; archaeologist; CONICET-UBA)*
- Small-find recording team:
Cristina Bacquerisse (B. A.; Egyptologist; CONICET-UBA)*
Natalia Bas (student UBA)
Claudia Bisso (student UBA)
- Lithic material recorder:
Adriana Chauvin (student UBA; CONICET-UBA)*
- Human remains recorder:
Claudia Bisso
- Restorer:
Graciela Arbolave
- Photographers:
Eduardo Crivelli
Susana Basílico
Claudia Kohen
- Inspectors of the SCA:
Mahmaud Mansour (field work)
`Ab Salam (lab work)

2000

No academic activities in Egypt. Research work was done in Buenos Aires

*Ad-honorem researchers in the former *Programa de Estudios de Egiptología (PREDE-CONICET)*, now the *Departamento de Egiptología (DEGIP)*, Instituto Multidisciplinario de Historia y Ciencias Humanas (IMHICIHU), CONICET, Buenos Aires. See [pp.2](#)

Seventh Campaign, 2001**September 6th -October 8th** ¹⁵

- Director of the Mission
Perla Fuscaldó
- Lab director and deputy director:
Silvia Lupo de Ferriol (M.A.; Egyptologist, CONICET)
- Pottery recorder:
Susana Basílico (M.A.; Archaeologist; CONICET-UBA)*
- Archaeoichthyological studies:
Alberto Cione (Ph.D.; Paleontologist; CONICET-Museo de Ciencias Naturales de La Plata)
- Pottery analyst
Beatriz Cremonte (Ph.D.; Archaeologist; CONICET)
- Sediment studies:
Eduardo Crivelli (Ph.D.; Archaeologist, CONICET)
- Pottery recorder:
Claudia Kohen (M.A.; Archaeologist; CONICET)*
- Lithic material recorder
Adriana Chauvin (M.A.; Archaeologist; CONICET)*
- Lab assistant
Ana Peñaloza (M.A.)
- Photographer:
Claudia Kohen
- Inspectors of the SCA:
`Ahmed Mahfouz
`Ahmed Raslan

2002**October 8th - November 17th**

- Director of the Mission:
Perla Fuscaldó
- Lab director and deputy director:
Silvia Lupo de Ferriol (M.A.; Egyptologist; CONICET)
- Archaeoichthyological studies:
Alberto Cione (Ph.D.; Paleontologist; CONICET-Museo de Ciencias Naturales de La Plata)
- Pottery analyst:
Beatriz Cremonte (Ph.D.; Archaeologist; CONICET)
- Pottery recorder:
Susana Basílico (M.A.; Archaeologist; CONICET)*
Claudia Kohen (M.A.; Archaeologist; CONICET)*
Silvina Vigliani (M.A.; Archaeologist; CONICET)*
- Lithic material recorder:
Adriana Chauvin (M.A.; Archaeologist; CONICET)*

*Ad-honorem researchers in the former *Programa de Estudios de Egiptología (PREDE-CONICET)*, now the *Departamento de Egiptología (DEGIP)*, *Instituto Multidisciplinario de Historia y Ciencias Humanas (IMHICIHU)*, CONICET, Buenos Aires. See [pp.2](#)

¹⁵ The lab work in Egypt was cancelled on September 20th for security reasons.

- Small finds recorder:
Cristina Bacquerisse (B.A.; Egyptologist; CONICET)*
- Lab assistant:
Ana Peñaloza (M.A.)
- Photographer:
Claudia Kohen
- Inspector of the SCA:
Ramadan Helmi Mohamed

Financial support

The field and lab work conducted in Egypt (1995-2002) as well as the research done in Argentina (1995-2005) were supported by *financial grants* from Argentine Governmental Agencies, and sponsored by individuals and companies. These are mentioned herein below:

1995:

Consejo Nacional de Investigaciones Científicas y Técnicas (CONICET), Facultad de Filosofía y Letras (Universidad de Buenos Aires), INVAP, Fundación Felipe Fiorellini. Lufthansa and Kodak Buenos Aires helped us with their products.

1996:

Consejo Nacional de Investigaciones Científicas y Técnicas (CONICET), Facultad de Filosofía y Letras (Universidad de Buenos Aires), Elsa Rosenvasser Feher (Emeritus professor), Claudia Kohen (M.A.), Fundación Felipe Fiorellini, INVAP, Fundación Banco de la Nación Argentina, Imageland S.A., volunteers Elsa Rosenvasser Feher, Graciela Arbolave, Susana Basílico, Juliana Garrote, Silvia Crochetti, Ana María Rosso, and students Pablo Ceriani and Eduardo Poli.

1997:

Consejo Nacional de Investigaciones Científicas y Técnicas (CONICET; Proyectos de investigación plurianuales, PIP 1997-1998, No. 4450: “La Misión Arqueológica Argentina en Tell el-Ghaba, Egipto”), Facultad de Filosofía y Letras (Universidad de Buenos Aires), Instrumental Pasteur, S.A., and Claudia Kohen and Susana Basílico.

1998-1999:

- a) *Agencia Nacional de Promoción Científica y Tecnológica (ANPyCT-Buenos Aires) through the Fondo para la Investigación Científica y Tecnológica (FONCyT), in the frame of the Programa de Modernización Tecnológica, Contrato de Préstamo “BID 802/OC-AR”, for two projects: 1.- PICT’ 97, No. 04-00150-02427, “Tell el-Ghaba, Egipto: excavación y registro documental”, under the direction of Eduardo Crivelli, and 2.- PICT’ 97, No. 04-00150-02430, “Tell el-Ghaba, Egipto: La cerámica local e importada. Análisis morfológico, macro y microscópico”, under the direction of Perla Fuscaldo and the participation of Beatriz Cremonete, Silvia Lupo de Ferriol and Susana Basílico (1998-1999), with the cooperation of Adriana Chauvin, Silvina Vigliani, Leticia Martínez and Paola Ramundo (1999);*
- b) *Universidad de Buenos Aires, Secretaría de Ciencia y Técnica (UBACYT 1998-2000,*

*Ad-honorem researchers in the former *Programa de Estudios de Egiptología (PREDE-CONICET)*, now the *Departamento de Egiptología (DEGIP), Instituto Multidisciplinario de Historia y Ciencias Humanas (IMHICIHU), CONICET, Buenos Aires.* See [pp.2](#)

TF/051: “*Tell el-Ghaba, Egipto: Arqueología de un sitio faraónico de época saíta*”);

c) Claudia Kohen, Susana Basílico and Graciela Arbolave. Anaeróbicos Argentinos S.A. helped us with its products.

2000:

Universidad de Buenos Aires, Secretaría de Ciencia y Técnica (UBACYT 1998-2000, TF/051).

2001:

a) *Consejo Nacional de Investigaciones Científicas y Técnicas (CONICET; PIP No. 4450;*

b) *Universidad de Buenos Aires, Secretaría de Ciencia y Técnica (UBACYT TF/051);*

c) Elsa Rosenvasser Feher and Claudia Kohen.

2002:

a) *Agencia Nacional de Promoción Científica y Tecnológica (ANPyCT-Buenos Aires) through the Fondo para la Investigación Científica y Tecnológica (FONCyT), in the frame of the Programa de Modernización Tecnológica, Contrato de Préstamo BID 802/OC-AR”, for the project: PICT’ 2000, No. 04-08867, “Tell el-Ghaba, Egipto: Excavaciones de rescate y análisis de laboratorio de un sitio saíta en el Delta Oriental”, 2002-2003, under the direction of P. Fuscaldó.*

b) *Consejo Nacional de Investigaciones Científicas y Técnicas (CONICET; PIP No. 4450);*

c) Claudia Kohen.

2003-2004:

Agencia Nacional de Promoción Científica y Tecnológica, PICT’ 2000, No. 04-08867.

Acknowledgements

The permission for the work was granted by the “Supreme Council of Antiquities” (SCA) of Egypt, to whom we are indebted, especially to the Director of this institution, *Dr. Zahi Hawass*, and the former directors since 1995 (*Dr. `Abdel-Halim Nur el-Din, Dr. `Ali Hassan* and *Prof. Gaballah `Aly Gaballah*); the help of the former Director of the “North Sinai Archaeological Salvage Project”, *Dr. Faiza Hekal*, and the members of the *Supreme Council of Antiquities* mentioned below are gratefully acknowledged: the General Inspector of Pharaonic Monuments, *Dr. `Abdel Halim Risk*, the General Inspector of North Sinai (1995-1998) and General Inspector of the Eastern Delta (since 1999), *Dr. Mohammed `Abd el-Maqsoud*; the General Inspector of North Sinai (since 1999), *Dr. Mohamed `Abdel Fattah `Abd el-Ghary*; the Inspector *Dr. Mohamed Kamel*; the inspectors in our Mission: *`Ezzat Fathy Masoued, `Ahmed Rashed `Amer, Mahmaud Mansour, `Ab Salam, `Ahmed Mahfouz* and *`Ahmed Raslan*, and especially to *Osama R. Hamza* and *Ramadan Helmi Mohamed*; and the former Chief of the Tourist Police in Ismailia, *Col. Sherif el-Husseini*, who solved many of our problems in Egypt. Special thanks to one of the workers, *`Es-Sayed `Abd el-`Al*, for his permanent loyalty to the Mission.

We are grateful to the former Director of *The Cairo Egyptian Museum, Dr. Mamdouh Eldamaty*, and the curator *Mrs. Elham Mountaser*, for allowing us to compare archaeological material from the Museum collections with Tell el-Ghaba objects (1999), and to *Mrs. May Trad* for her unfailing help during our visits to this Museum. We also thank the Director of the *Archaeological Centre at Abu Seifa, Dr. `Ab el-Samir*, for offering us the Centre as the Mission House (2001-2002).

We wish to thank all *the members and volunteers of the Argentine Archaeological Mission at Tell el-Ghaba* mentioned in the *Calendar of fieldwork and study seasons*

(1995-2002), for their dedication. Special thanks to *Dr. Silvia Lupo* and *Susana Basílico (M.A.)* for their permanent assistance in the organization of the Mission and in the pottery work; to *Dr. Elsa Rosenvasser Feher*, who sponsored the campaign in 1996 and donated a *Geoscan Resistance Meter RM15 with Multiplexer* and a *Geoscan Gradiometer Flux-Gate type FM18* (1998) in “the name of the children of Prof. Dr. Abraham Rosenvasser, in his honour”; and to *Claudia Kohen (M.A.)*, who sponsored field photography, created an *ad-hoc* database for the Mission, digitized the field and lab documentation, and generously and permanently helped in all the activities of the Mission in Buenos Aires and in Egypt.

We are also indebted to the former *Secretary of Sciences and Technology, University of Buenos Aires (Secretaria de Ciencia y Tecnología, Universidad de Buenos Aires)*, *Dr. Alicia Fernandez Cirelli*, to the former *Dean of the School of Philosophy and Letters* of the same University, *Luis Yanes (M.A.)*, and to the General Director of the FONCyT (1998), *Dr. Carlos M. Marschoff*, for their help in getting the financial support on time, and to the former Vice-Dean of the *School of Humanities, Maimonides University, Prof. Regina Steiner*, for her enthusiastic support.

We are greatly indebted to:

- *Dr. Eduardo Crivelli* (CONICET), for his careful work in the field;
- *Dr. Beatriz Cremonte* (CONICET, *Instituto de Mineralogía, Universidad Nacional de Jujuy*) for her work on the imported fabric typology from the site;
- *Susana Basílico*, for the preparation of the plans in Autocad (plans of the site and the buildings);
- *Dr. Alberto Cione* (CONICET and *Museo de Ciencias Naturales de La Plata*), for his studies on the fauna from Tell el-Ghaba;
- *Dr. Jorge Trench†*, for the geophysical survey he made in the site (1998-1999);
- *Dr. Tomasz Herbich*, for reviewing the files of the 1999 survey, in the frame of the agreement between the Argentine Archaeological Mission and the Polish Centre of Mediterranean Archaeology in Cairo (2004);

We are thankful to the following members of the Austrian Archaeological Mission at Tell el-Dab`a, *Prof. Dr. Manfred Bietak*, Director of the *Austrian Archaeological Institute in Cairo* and of the *Austrian Mission at Tell el-Dab`a*, for encouraging me to work at Tell el-Ghaba; and to him and to *Dr. Joseph Dorner* for teaching me the methodology for recording field and lab work; to *Dr. David Aston* and *Dr. Irmgard Hein* for help and advice on Egyptian pottery and on imported ceramics respectively; to *Mag. Rudolfin Seeber* for her advice on restoration problems, and to her and *Dr. Joseph Dorner* for providing material for our work in 1998; and to *María Antonia Negrete Martinez* and *Nicola Math* for their advice on archaeological drawing;

Special thanks to *Prof. Dr. Eliezer Oren*, Director of *The Canadian Chair of Archaeology, Ben Gurion University of the Negev*, for allowing me to have access to the field and ceramic documentation of his survey in North Sinai;

- *Dr. Yubal Goren*, from the *Institute of Archaeology, University of Tel Aviv*, for his advice on Levantine fabrics;
- *The Agencia Nacional de Promoción Científica y Tecnológica-Buenos Aires* for the financial support;
- *Prof. Dr. Angela von den Driesch*, from the *Institut für Paläoanatomie, Domestikationsforschung und Geschichte der Tiermedizin der Universität München*, for her advice on the fauna (2002);
- *Dr. Tomasz Herbich* (the former Director of *The Polish Centre of Mediterranean Archaeology, Cairo*), *Dr. C. Becker* and *Dr. J. Fassbinder* (Bayer Landeswamt für Denkmalpflege, München) and *Dr. Edgard Pusch* (Director of the *Hildesheim Mission at Qantir*), for their general advice on the geophysical survey during the campaign of 1998;
- *Cristina Bacquerisse (M.A.)*, for her enthusiastic cooperation in the lab work;

- *Dr. Grzegorz Majcherek*, the Director of *The Polish Mission at Kom el-Dikka*, for his evaluation of the Coptic and early Islamic pottery found in a Bedouin deposit at Tell el-Ghaba in 1997;
- *Dr. Maciej Pawlikowski*, the Head of *Commission of Mineralogical Sciences, The Polish Academy of Sciences, Crakow*, for his unfailing support and advice on geological and mineralogical problems;
- *Dr. Carlos Limarino* and *Dr. Roberto Koko*, and their team (*Departamento de Geología, Cátedra de Sedimentología, Facultad de Ciencias Exactas y Naturales, Universidad de Buenos Aires*), for the special seminar they organized for the members of the Mission (1995);
- *Dr. Carlota Sempé*, the Director of the *Laboratorio de Análisis Cerámico, Universidad Nacional de La Plata*, and her assistant, *Dr. Nora Zagorodny*, for their cooperation in the fabric analysis in 1997;
- *Dr. Amalia Sanguinetti de Bórmida*, the Director of the former “*Programa de Estudios Prehistóricos-CONICET*”, for her permanent and enthusiastic support;
- *Dr. Héctor Pucciarelli* (*CONICET* and *Museo de Ciencias Naturales de La Plata*) for his advice on bioanthropological studies;
- *Topographer Marta Búcola*, for her field work in 1998 and her assistance in the 1999 campaign;
- The members of the Embassy of the Argentine Republic in Cairo, *Ambassadors Domingo Cullen* and *Osvaldo Pascual*; *Ministers Juan José Santader* -with whom we visited Tell el-Ghaba for the first time-, *Felipe Alvarez de Toledo* and *Catalina Santalesa*; *First Secretary, Ana Peñaloza*, and *Eduardo Acuña*; *Military Counsellor*, the late *Cnl. Luciano Teodoro Parszyk*, and the Egyptian members of the Embassy, *Seham Amin Ghaly* and *El Sayed Soheim*;
- The President of INVAP, *Juan José Gil Gervino*, for his financial support in 1995, and the members of the same company, *Carlos Amaya*, *Santos Mesina* and *Mónica Somma de Spahr*;
- *Marcelo Politi* (1995 and 1998) and *Sandra Messina*, for their assistance in Cairo;
- *Lyla Pinch Brock*, for her always useful advice;
- *Rosalía López Herrera*, for the teaching of Egyptian Arabic.

We thank *Santos* and *Sandra Mesina*, *Tomek* and *Malgorzata Herbich*, *Ana Peñaloza*, *Osvaldo* and *Juana Pascual*, and *Jaime* and *Susana Cornejo Saravia*, for their company while we were in Cairo. We give my warm thanks to *Elsa Rosenvasser Feher* and *Claudia Kohen* for reviewing the English version of this manuscript.

Reports prior to this publication

1997

1. Fuscaldó, P., “Tell el-Ghaba: Tres campañas de rescate arqueológico en Egipto”, *Ciencia e Investigación* 50, No.1-2, 31-38.

1999

2. Pereyra de Fidanza, V., E. Crivelli Montero, S. Lupo, S. Fantechi and A. Zingarelli, “Tell el-Ghaba: Three Seasons of Excavations in North Sinai”. *Proceedings of the Centenary of Mediterranean Archaeology at the Jagiellonian University 1897-1997, Cracow* (Cracow), vol. II, 59-73.

2000

3. Fuscaldó, P., “Tell el-Ghaba (North Sinai)”, *BCE* XXI, 3-6.

4. Fuscaldo, P., "Three Campaigns of the Argentine Archaeological Mission at Tell el-Ghaba, North Sinai, Egypt. A Salvage Project", in P. Matthiae, A. Enea, L. Peyronel and F. Pinnock (eds.), *Proceedings of the First International Congress on the Archaeology of the Ancient Near East, Roma, May 18th – 23rd, 1998* (Roma), 523-529.

2002

5. Fuscaldo, P., S. Basílico, B. Cremonese and S. Lupo, "A Preliminary Report on the Pottery from Tell el-Ghaba, a Saite Settlement in North Sinai", in Z. Hawass (ed.), *Egyptology at the Dawn of the Twenty-first Century. Proceedings of the 8th International Congress of Egyptologists, Cairo, March 23rd – April 3rd, 2000* (The American University in Cairo, Cairo), vol. 1, Archaeology, 189-192.
6. Lupo, S., and S. Basílico, "On the Chronology of Tell El-Ghaba, North Sinai", *BACE* 13, 127-134.
7. Basílico, S. y S. Lupo, "Tell el-Ghaba, un asentamiento de frontera de época saíta en el norte del Sinaí. La cerámica egipcia e importada del Área I". *Actas del 1er. Congreso Nacional de Arqueología Histórica, Mendoza 9-11 de Diciembre del 2000* (Buenos Aires), 843-852.
8. Crivelli Montero, E., C. Kohen y A. Chauvin, "Tell el-Ghaba, Sinaí Norte, Egipto: el asentamiento y la economía". *Actas del 1er. Congreso Nacional de Arqueología Histórica, Mendoza, 9-11 de Diciembre del 2000* (Buenos Aires), 833-841.
9. Lupo, S., and S. Basílico, "The Pottery from Tell el-Ghaba, North Sinai, exhibited at the Abu Seifa Archaeological Centre", in M. Eldamaty and Mai Trad (eds.), *Egyptian Museum Collection around the World. Studies for the Centennial of the Egyptian Museum* (Cairo), vol. II, 753-762.
10. Rosso, A. M., "Le symbolisme religieux des *oudjats* de Tell el-Ghaba: les problèmes techniques de leur préservation", in Z. Hawass (ed.), *Egyptology at the Dawn of the Twenty-first Century. Proceedings of the 8th International Congress of Egyptologists, Cairo, March 23rd – April 3rd, 2000* (The American University in Cairo, Cairo), vol. 3, Language, Conservation, Museology, 380-386.

2003

11. Lupo, S. y S. Basílico, "La cerámica como indicadora de la cronología de un sitio de frontera: el caso de Tell el-Ghaba, norte de Sinaí, Egipto", in M. Ramos y E. Néspolo (eds.), *Signos en el tiempo y rastros en la tierra, Actas de las III Jornadas de Arqueología e Historia de las Regiones Pampeanas y Patagónica, Universidad Nacional de Luján, 6-8 de Septiembre del 2000* (Luján), 297-305.

2004

12. Basílico, S. and S. Lupo, "Tell el-Ghaba, North Sinai: The Pottery from Buildings A and B", *BCE* XXII, 3-11.

2004 (in print)

13. Fuscaldo, P., "The Argentine Archaeological Mission at Tell el-Ghaba. Last Results". *Proceedings of the Second International Congress on the Archaeology of the Ancient Near East, Copenhagen, May 22nd-26th, 2000* (Eisenbrauns, Winona Lake).

1996-1997 (2005)

14. Fuscaldo, P., E. Crivelli Montero, M. V. Pereyra de Fidanza and A. Zingarelli, "A Preliminary Report on the Three Campaigns of the Argentine Archaeological Mission at Tell el-Ghaba, North Sinai, Egypt, 1995-1997 (Excavations and Study Seasons)", *REE* 6-7 (CD version).

2005 (in print)

15. Fuscaldo, P., "The Egyptian Painted Wares from Tell el-Ghaba, North Sinai (early 26th Dynasty)", 2003.
16. Fuscaldo, P., S. Lupo and S. Basílico, "Tell el-Ghaba, a Border Site from the Early Saite Period (Function of the Buildings)". *Proceedings of the 4th International Congress on the Archaeology of the Ancient Near East*, Freie Universität Berlin, Berlin, March 29th-April 3rd, 2004.
17. Lupo, S. and S. Basílico, "The Final Stage and Abandonment of Tell el-Ghaba, North Sinai: a Site on the Egyptian Eastern Border". *Proceedings of the 9th International Congress of Egyptology, Grenoble, 4th-12th of September 2004*.
18. Basílico, S. and S. Lupo, "Tell el-Ghaba, un asentamiento de frontera de época saíta en el Norte de Sinaí, Egipto. La cerámica egipcia e importada del Área II". *Actas del simposio "La investigación arqueológica del antiguo Egipto: estudios de hallazgos"*, XV Congreso Nacional de Arqueología Argentina, Río Cuarto, Córdoba, Argentina, 20-25 de Septiembre del 2004.
19. Kohen, C., "La presencia de pesas de telar en Tell el-Ghaba: conjeturas sobre la manufactura de textiles en un sitio del norte del Sinaí durante la época tardía". *Actas del Simposio "La investigación arqueológica del antiguo Egipto: estudios de hallazgos"*, XV Congreso Nacional de Arqueología Argentina, Río Cuarto, Córdoba, Argentina, 20 al 25 de Septiembre del 2004.

List of Maps*

Map I: Egypt, the Nile Delta.

Map II: The Eastern Delta. The Suez Canal-Pelusium area with archaeological sites (adapted from D. Valbelle, F. Le Saout, M. Chartier-Raymond, M. Abd el-Samie, C. Traunecker, G. Wagner, J.-Y. Carrez-Maratray, P. Zignani, “Reconnaissance archéologique à la pointe orientale du Delta. Rapport préliminaire sur les saisons 1990 et 1991”, *CRIPPEL* 14 (1992), Fig. 1).

* Digitilized by Perla Fuscaldo

TELL EL-GHABA I

Catalogue **Introduction**

by Perla Fuscaldo, Eduardo Crivelli Montero, Silvia Lupo and Susana Basílico

Catalogue

The *Catalogue* includes the stratigraphy of Tell el-Ghaba and the archaeological material found in the site. After the stratigraphic description, the material is presented here by areas and loci. This volume is divided into three different parts that involve the stratigraphy and archaeological material related to the structures from Area I, Area II and Area VI, respectively. There is also a brief description of the excavation and recording methods. The material from other loci of Areas I, II and VI, and from Areas III and V (Plan VII) will be included in the second volume of this publication (*Tell el-Ghaba II, Studies*, forthcoming).

The *Catalogue* is based on the database files of the Mission in Microsoft Access.¹⁶ The stratigraphy was made by Eduardo Crivelli Montero with the cooperation of Claudia Kohen. The pottery catalogue was prepared by Perla Fuscaldo, Silvia Lupo and Susana Basílico, and the finds catalogue by Perla Fuscaldo and Cristina Bacquerisse, except for the lithics¹⁷ (which was done by Adriana Chauvin), the wdjats¹⁸ (by Ana María Rosso), and the scarabs, scaraboids, button seals and plaques with epigraphy¹⁹ (by María Violeta Pereyra de Fidanza and Silvana Fantechi). The final form of “The Catalogue” and the digitized drawings were prepared by Perla Fuscaldo²⁰.

Methodology

a) Methods of excavation, by Eduardo Crivelli Montero

The architect of the Mission, Antonio Balogh-Kovács, established a grid of 5 x 5 m squares in 1995. Although the excavation was carried out in accordance with Edward Harris' proposals, more attention was paid to sections.

¹⁶ For the recorders in Egypt see below (note 25).

¹⁷ F0011A, F0023A, F0028A, F0031A, F0036A, F0040, F0075A, F0077A, F0078, F0080A, F0082B, F0089A, F0109A, F0114, F0136A, F0142A, F0144A, F0149A, F0156, F0157A, F0161A, F0167A, F0168A, F0182A, F0183A, F0184A, F0219A, F0219A, F0220A, F0225A, F0233A, F0234A, F0236A, F0240A, F0241A, F0242, F0255A, F0265A, F0268A, F0305A, F0328, F0334A, F0335A, F0343A, F0346A, F0347, F0355A, F0357A, F0372A, F0378A, F0382A + F0383A, F0396, F0401A, F0405A, F0409A, F0426A, F0427A, F0473A, F0478A, F0479A, F0496A, F0501A, F0502A, F0503A, F0504A, F0505A, F0506A, F0507A, F0508A, F0509A, F0510A, F0535A, F0536A, F0537A, F0538A, F0539A, F0540A, F0542A, F0547A, F0568A, F0569A, F0570A, F0571A, F0572A, F0573A, F0574A, F0575A, F0576A, F0578A, F0579A, F0580A, F0581A, F0583A, F0584A, F0673A, F0675A, F0735A, F0739, F0752A, F0810A, F0814, F0816A, F0817A, F0819A, F0820A, F0821A, F0822A, F0823A, F0828A, F0829A, F0831A, F0832A, F0845A, F0847A, F0870A, F0875A, F0900A, F0901A, F0902A, F0904A, F0905A, F0906A, F0907A, F0908A, F0910A, F0910A, F0911A, F0912A, F0913A, F0914A, F0916A, F0917A, F0918A, F0919A, F0934A, F0935A, F0936A, F0938A, F0940A, F0941A, F0942A, F0943A, F0945A, F0946A, F0948A, F0950A, F0951A, F0952A, F0953A, F0954A, F0955A, F0956A, F0957A, F0958A, F0959A, F0960A, F0961A, F0962A, F0963A, F0964A, F0965A, F0966A, F0967A, F0968A, F0969A, F0970A, F0971A, F0972A, F0973A, F0974A, F0975A, F0976A, F0977A, F0978A, F0979A, F0980A, F0981A, F0982A, F0983A, F0984A, F0985A, F0986A, F0987A, F1075A, F1076A, F1077A, F1078A, F1079A, F1080A, F1081A, F1082A, F1083A, F1084A, F1085A, F1086A, F1087A, F1088A, F1089A, F1090A, F1091A, F1092A, F1093A, F1094A, F1095A, F1096A, F1097A, F1098A, F1099A, F1100A, F1101A, F1102A, F1103A, F1104A, F1105A, F1106A, F1107A, F1108A, F1109A, F1110A, F1111A, F1112A and F1120A.

¹⁸ Inv. No. F0006, F0007A, F0013, F0014A, F0033, F0041, F0043, F0044, F0045, F0046, F0047, F0048, F0049, F0050, F0051A, F0052A, F0053, F0054, F0055A, F0056, F0057, F0058A, F0063, F0065, F0066A, F0067, F0068, F0069A, F0073, F0076, F0094, F0099, F0118, F0125A, F0138, F0151, F0154A, F0159, F0160, F0165, F0174, F0195, F0201, F0217, F0218, F0244, F0251, F0295, F0297A, F0440A, F0444, F0468, F0476, F0483, F0532 and F9554A.

¹⁹ F0015, F0019, F0072, F0083, F0092, F0166, F0235, F0274, F0280, F4034A, F0491, F0492A, F0622, F0629, F0636A, F0640A, F0650 and F0655.

²⁰ The photographs published in this volume were taken from the documentation done in Egypt by the members of the Mission, see *Introduction*, § *Calendar of fieldwork and study seasons in Egypt (1995-2002)*.

Each stratigraphic unit (known as *locus* in Tell el-Ghaba, and commonly in the Near East) is identified by a number in the single series of numbers valid for the whole site. Examples of *loci* are floors, floor preparation, walls, pits (P), ditches, fill of pits, tombs, debris layers, natural lenses of sediments, etc. Each locus is recorded and described in a *locus sheet* that also indicates the stratigraphic relationships. Complementary forms have been designed for walls, installations, tombs, etc. Special software has been used to facilitate the compilation of the stratigraphy.

The excavation is performed following each stratigraphic unit. Each square is under the supervision of an archaeologist who manages a couple of local workers and does the recording. These workers have been trained by the archaeologists of the Mission to use their tools according to the kind of context and have gained some experience in several digs. Total or partial sieving of the sediments is carried out and samples are floated in the Mission house. Plans and sections are drawn at a scale of 1:20, many photographs (black and white, colour and also slides) are taken and some video recording is also done. Important finds are plotted in plans.

The exploration of the tell was first performed by means of slit trenches, dug until the first feature was found; but then, geophysical survey was performed, with good results (Plans X and XI).²¹

The field team and a software specialist designed a computerized data model for the site. Based on a standard Database Management System, the aim was to create a specific application to serve the multiple purposes of storage, retrieval and analysis of the archaeological material. A field database is intended to record the properties of finds and loci and their relationship between them. In the case of Tell el-Ghaba the established basic archaeological unit is the “locus”, whose attributes are recorded on a “*locus sheet*”. Links to accessory sheets (i.e. *Wall sheet*, *Installation sheet*, *Floor sheet*, *Tomb sheet*, *Radiocarbon sample sheet*, *Other samples sheet*, *Operation sheet*, *Structure sheet*), complementary databases (i.e. those of *Pottery*, *Lithics*, *Small finds* and *Faunal remains*), Harris matrixes, and digitized graphic information are used to recreate the original contexts.

b) Methods of lab recording. Pottery recording, by Perla Fuscaldo, Silvia Lupo y Susana Basílico²².

The pottery was initially separated according to the field provenance and classified as Egyptian or Imported. Egyptian fabrics were analysed according to the Vienna System²³ that we adapted to our ceramic repertoire from the 1st millennium BC. Egyptian body sherds also underwent this analysis, to be later measured in dm² for statistical purposes. The analysis of the Egyptian fabrics was made on a fresh break, with a 10-20X manual lens under the sunlight. All the imported pottery was registered, notwithstanding they were body sherds, and analysed under a 40-120X binocular magnifying glass for its fabric classification.

We adopted the general classification used in the Austrian Archaeological Mission at Tell el-Dab`a/Avaris for foreign fabrics: IV for Levantine, VI for Cypriote and VII for Aegean fabrics. The Arabic number after the Roman number is the same as that used in Tell el-Dab`a for the imported fabric from the end of the Second Intermediate Period and the New Kingdom when we have the same fabric at Tell el-Ghaba. For the other fabrics we

²¹ Jorge Trench, “The Geophysical Survey of the Site. Methodology and Results”, in *Tell el-Ghaba II, Studies* (forthcoming).

²² Fuscaldo, Basílico, Cremonte and Lupo, in Hawass, ed, *Proceedings of the 8th International Congress of Egyptologist*, vol. 1, 189-192; Lupo and Basílico, *BACE* 13, 127-134.

²³ Nordström and Bourriau, in Arnold and Bourriau (eds.), *An Introduction to Ancient Egyptian Pottery*, 175-182.

used our own fabric typology preceded by the abbreviation TG. The imported fabric typology was prepared by Beatriz Cremonte. A brief description of pottery fabrics is included in [Tables I and II](#) (Description of local and non-local fabrics).

All the Egyptian and imported pottery was registered either in the inventory or in the context records.²⁴ The inventory pieces are those whose shape and decoration are more representative and which contain a more complete section, while the context sherds are the most fragmentary ones. The variables taken into account for these registrations were the field provenance, type of vessel, part preserved (rim, base, handle, etc), measures (rim, neck, base and major diameter, heights and wall thickness, handle diameter), fabric, manufacturing technique (thrown on the wheel, by hand), matrix, firing, hardness (according to the modified Mohs scale), surface and break colour (according to the *Munsell Soil Color Charts*, 1994 revised edition), surface treatment (smoothed, polished, burnished), and decoration, if any. All the recorded pottery was drawn in the scale 1:1, and the pottery from the Inventory has been partially photographed.²⁵

Two databases in Microsoft Access, one for the Inventory and the other for the Contexts, were used for storage of this information, which was fundamental for the study of the pottery. Perla Fuscaldo, Silvia Lupo and Susana Basílico carried out this task.

On the archaeological material from the Catalogue, by Perla Fuscaldo

The archaeological material is divided into two: **Pottery** and **Finds**.

Pottery comprises **Egyptian** and **imported** ceramics, classified by *fine* and *household wares, pottery with special functions*, and *votive ware*. In turn Egyptian pottery is divided according to the clay in two main groups: **Nile silt clay** and **Egyptian marls**.

Imported pottery is classified by the main areas of probably origin: **North Sinai/South Palestine, Levantine, Cypriote** and **Aegean**, and arranged in *fine* and *household wares*. Although complete vessels are very scarce, many Egyptian pots were incorporated in the Inventory as well as nearly all the imported fine wares.

The pottery with painted decoration / polished or burnished surface was classified as *fine ware*. Distinction was especially made according to the morphology. Fabrics were considered only for practical variations observed in the same morphology.

The pottery (fine and household ware and the votive pottery) was arranged in *open* and *closed shapes*. When designed, rim position was established leaning it on a horizontal surface to observe and determine its definitive position. This allowed us to classify the pottery according to the mouth aperture in open and closed shapes. **Rims** were classified according to whether they were direct or unmodelled, and/or have an articulation to the exterior or the interior of the vessel. Rims with both articulations that look regular were called symmetrical. Lip shapes were defined as follows: every lip round in shape can be named round, rounded or rolled; lips with a sharp inclination inwards or outwards are called trimmed or bevelled; irregular lips are defined as modelled. Lips extremely projected outwards are pendant.²⁶

Cups with more than 10 cm of rim diameter are considered deep bowls, and jars with 20 cm or more of rim diameter were are called storage jars.

The **registered pottery** from the Inventory is presented in the *Catalogue* with the references mentioned below.

Above the boxes:

- **order number** given to the described pot in this book;

²⁴ The pottery of Tell el-Ghaba is very fragmentary and few vessels are preserved complete.

²⁵ For the recorders in Egypt, see the *Introduction*, § *Calendar of fieldwork and study seasons in Egypt (1995-2002)*.

²⁶ Lupo and Basílico, personal communication.

- **type of vessel**;
 - between brackets the **figure** where it is drawn;
 - **inventory number in the record** of the Mission, preceded by **P** (= Pottery), numbered in whole numbers if it is stored in the magazine of the Supreme Council of Antiquities (SCA) at New Qantarah, followed by **A** if it is stored in the magazine of the Mission at the Abu Seifa Archaeological Centre, and **B** if it is exhibited in the museum of the same centre;
 - between brackets the **drawing number in the record** of the Mission;
- Inside the boxes:
- **ware**;
 - **fabric**, in the “Vienna system” for the Egyptian fabrics, and in the Tell el-Ghaba system for the imported ones (preceded by **II** for the North Sinai/South Palestine fabrics, **IV** for the Levantine, **VI** for the Cypriote and by **VII** for the Aegean, and followed by **TG** and the **number** given for each fabric in the Tell el-Ghaba fabric typology);
 - **manufacturing method**;
 - **shaping technique of the base**;
 - **firing index**;
 - **hardness**, in the modified Mohs scale.

Below the boxes:

- **part preserved, attributes and contour**;
- **size**, and **vessel index** if the shape is complete;
- **surface colour** according to the *Munsell Soil Color Charts* (1994 revised edition);
- **break**; for the **inclusions** see a brief description of the fabrics in the “Vienna system” for the Egyptian pottery ([Table I](#)), and the Tell el-Ghaba fabric typology for the imported ([Table II](#));
- **technical details**;
- **decoration**;
- **surface treatment**;
- **secondary uses**;
- **SCA number**;
- references to the **place where it was found**, if it is not mentioned before the description of the vessel.

Because of the fragmentary condition of the vessels, the sherds were registered in **contexts** not only for diagnosis of shapes, fabrics and wares, and for statistical analysis, but also for the shape typology. They are presented in the *Catalogue* in a shorter form, which includes

Above the boxes:

- **order number** given to the described pot in this book;
- **type of vessel**;
- between brackets the **figure** where it is drawn;
- **context number** where it is registered, and between brackets the **order number in the context**;

Inside the boxes:

- **ware**;
- **fabric**, in the “Vienna system” for the Egyptian fabrics, and in the Tell el-Ghaba system for the imported (preceded by **II** for the North Sinai/South Palestine fabrics, **IV** for the Levantine, **VI** for the Cypriote and by **VII** for the Aegean, and followed by **TG** and the **number** given for each fabric in the Tell el-Ghaba fabric typology);
- **manufacturing method**;
- **shaping technique of the base**, if it is preserved;

Below the boxes:

- **part preserved, attributes and contour**;

- **size;**
- **technical details;**
- **surface treatment and secondary uses;**

The other sherd material from the contexts not recorded for diagnostic purposes (**body sherds**) is measured by fabrics in dm².

Finds are classified by **type of object** and described with the following references:

- **order number** given to the described object in this book;
- **type of object;**
- between brackets the **figure** where it is drawn or the **plate** where the photography is published;
- **inventory number in the record** of the Mission, preceded by **F** (= Find), and numbered in whole numbers if it is stored in the magazine of the Supreme Council of Antiquities (SCA) at New Qantarah, followed by **A** if it is stored in the magazine of the Mission at the Abu Seifa Archaeological Centre, and **B** if it is exhibited in the museum of the same centre;
- between brackets the **drawing number in the record** of the Mission;
- the **material, manufacture technique, size, colour, description and function**, if it is known.

Slag was recorded with an inventory number only for practical reasons.

For the abbreviations see the **List of Abbreviations in the Catalogue**.

List of Abbreviations used in The Catalogue

Bd: base diameter
 BP: brown polished
 BPBI: Bichrome decoration on brown/reddish yellow polished slip
 BS: brown smoothed slip
 BSMO: monochrome decoration on brown smoothed slip
 C-: context
 c.: coarse
 D: diameter
 f.: fine
 GBP: grey brushed polished slip
 H₁: total height of the vessel
 H₂: height from the base to the major diameter
 H₃: height of the neck
 H₄: height of the base or foot
 Ha: hand-shaping technique of the base
 Ha₁: hand-shaping technique
 Ha₂: part of the vessel is hand-made
 Hd: handle diameter
 L: locus
 L.: length
 Md: major diameter
 MO: monochrome
 ox.: fired in an oxidizing atmosphere
 P: polished or burnished
 PSBI: bichrome decoration on pink smoothed slip
 R₁: ring base made by hand

R₂: ring base made on the wheel and raised in the middle
 R₃: ring base made on the wheel and lowered in the middle
 RBP: red brushed polished slip
 re.: fired in a reducing atmosphere
 Rd: rim diameter
 RP: polished or burnished red slip
 RPMO/RPBI: monochrome (outside) and bichrome (inside) decoration on red polished slip
 RS: smoothed red slip
 RSMO: monochrome decoration on red smoothed slip
 "s": "sandwich" ware
 s.: sandy
 TD: Tell el-Dab`a/Avaris
 TG: Tell el-Ghaba
 UncMO: monochrome decoration on uncoated surface
 UncRS: uncoated exterior, red slipped smoothed interior
 v.f.: very fine
 v.s.: very sandy
 VI: vessel index
 W: base made on the wheel
 W.: width
 W₁: low-stemmed simple wheel
 W₂: tall-stemmed simple wheel
 WP: whitish (white to pink and yellow) polished slip
 WPBI: bichrome decoration on whitish (white to pink and yellow) polished slip
 WPMO: monochrome decoration on whitish polished slip
 WS: white smoothed slip (or whitish self slip)
 WSBI: bichrome decoration on whitish smoothed slip
 WSMO: monochrome decoration on whitish slip

LIST OF PLANS, SECTIONS, GRAPHICS AND PLATES

Plans

- Plan I:** Plan of Tell el-Ghaba showing the areas excavated and surveyed by the Argentine Archaeological Mission (1995-1999) (Topographic plan by Antonio Balogh-Kovács (1995-1996) and Marta Búcola (1998); Autocad version by Susana Basílico).*
- Plan II:** Area I, Building A and Structure G (Autocad version by Susana Basílico).*
- Plan III:** Area I, Building B (Autocad version by Susana Basílico).
- Plan IV:** Area I, workshops (BA/41, oven L0186, top plans 3 and 4 by Eduardo Crivelli; BB/41, oven L0067, top plans 3 and 4 by Marila Kapika)*.
- Plan V:** Area II, Buildings C and D, 1998 (Autocad version by Susana Basílico).
- Plan VI:** Area II, Buildings L and D (Autocad version of Building D by Susana Basílico; Building L and digitalisation for the publication by Claudia Kohen).
- Plan VII:** Area V, Building E (Autocad version by Susana Basílico).*
- Plan VIII:** Area VI, Building F (Autocad version by Susana Basílico).
- Plan IX:** Area III, remains of mud brick structures, Nabil Sharif excavation, SCA, 1992 (Topographic plan by Antonio Balogh-Kovács, 1995; Autocad version by Susana Basílico).
- Plan X:** Geophysical survey of Tell el-Ghaba, Area VI (1998. Geophysical survey by Jorge Trench†; topographer: Marta Búcola; file for publication by Tomasz Herbich, 2004).
- Plan XI:** Geophysical survey of Tell el-Ghaba, Areas I, VII and VIII (1999). Geophysical survey by Jorge Trench†; file for publication by Tomasz Herbich, 2004.

Sections*

- Plan XII:** Area II, west section, Operation 26. Section of N and E walls, by Eduardo Crivelli Montero.
- Plan XIII:** Area II, west section, Operation 26. Section of S and W walls, by Eduardo Crivelli Montero.

Plates*

- Plate I, 1:** Tell el-Ghaba in 1995.
- Plate I, 2:** Tell el-Ghaba at dawn.
- Plate II:** Area I. Work under Building B.
- Plate III:** Area I. Building B completely exposed, seen from the northwest. The concentric ditches and associated pits among baulks to the right end of the picture are Structure G.
- Plate IV:** Area I. Structure G during excavation, seen from the southeast.
- Plate V:** Area I, workshop (oven L 0274. Pottery plate (Inv. No. P758A) *in situ* in L0314 (fill of the drain L0315).
- Plate VI:** Area I, remains of the burnt floor of Building A under Building B.
- Plate VII:** Area I, Building A, context L0356: doughnut-shaped pottery loom weights and two small vessels deposited in the foundation trench L0102. Mud bricks in the lower part of the picture belong to overlying Building B.

*Digitized in Adobe Photoshop for the publication by Perla Fuscaldo.

Plate VIII: Area I, BA/43, L0001, west section. Note lenses of oxidized sediment in the base of L0001.

Plate IX: Area II. Building D completely exposed, seen from the west. In four casemates or rooms, the excavation of underlying Building L has begun.

Plate X: Area II. A part of Building L during excavation, as seen towards west. Note foundation sand L1412 under mud brick wall L1107. On the lower right of the picture, two doughnut-shaped loom weights (L1408) can be seen inside the burnt fill of ditch L1411 (Building M).

Plate XI: Area II, Building L. Storage jars as found *in situ*.

Plate XII: Area II, Operation 99/2, L1203, west section No.1.

Plate XIII: Area VI. Building F partially exposed, seen from the east. Test pits have been dug in four rooms.

Graphics (Harris matrix)**

Graphic I: Area I (sketch).

Graphic II: Area II, east section.

Graphic III: Area II, west section, Operation 25.

Graphic IV: Area II, west section, Operation 26.

Graphic V: Area II, west section, Operations 32, 33, 34 and 35.

Graphic VI: Area II, west section, Operations 36 and 41.

Graphic VII: Area VI.

** by Eduardo Crivelli Montero

EGYPTIAN CHRONOLOGY

Early 26th Dynasty kings

Psametichus I (54 years): 664-610 BC

Necao II (15 years): 610-595 BC

Psametichus II (6 years): 595-589 BC

Apries (19 years): 589-570 BC

(from K. A. Kitchen, *The Third Intermediate Period in Egypt 1100-650*, Warmister, Aris & Phillips, 1972, 467)

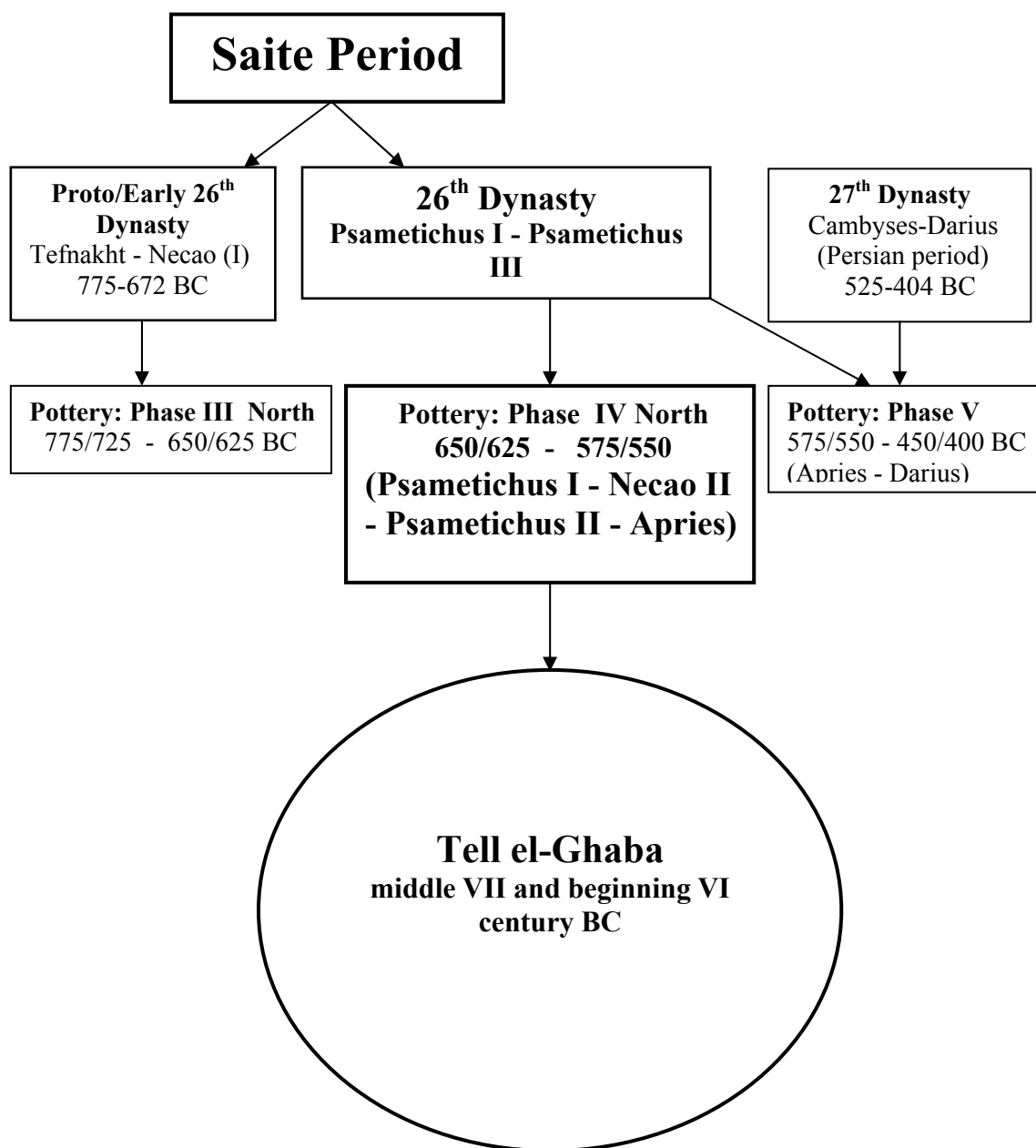


TABLE I: EGYPTIAN FABRICS ACCORDING TO THE "VIENNA SYSTEM" AND OTHERS NOT INCLUDED THERE. A BRIEF DESCRIPTION*

Nile silt clay	
Nile B ₁	Groundmass: relatively silty; inclusions of sand; micaceous particles; scattered fine straw particles as impressions in the clay and as silica skeletons of the plant structure.
Nile B ₂	The groundmass is similar in character to Nile B ₁ , but mineral and organic inclusions occur in larger sizes and in greater quantities.
Nile C ₁	Fairly silty clay with fine to coarse sand grains and a predominance of fine straw inclusions.
Nile C ₂	Fairly silty clay with fine to coarse sand grains and an abundance of coarse particles of straw inclusions.
Nile E ₁	Fine, medium and coarse rounded sand grains and fine straw inclusions.
Nile E ₂	Inclusions of fine, medium and coarse rounded sand grains.
Egyptian marls	
Marl A ₄	Marl A: a dense, homogenous groundmass containing fine mineral inclusions and very little organic matter. Variant 4: coarse texture and great quantity of fine to coarse sand inclusions, with a considerable range of colour, porosity and hardness. Colour: pink (7.5YR 7/4) to pale yellow (5Y 7/3).
Marl F	An eastern Nile Delta or North Sinai marl clay. In its most common form, the section fires a uniform very pale brown with a surface colour of white to dirty grey. Inclusions within the paste comprise sand, limestone grits and the occasional small pebble. Section: a uniform very pale brown colour; surface: white to dirty grey colour. Variants: Marl F sandy, Marl F very sandy, and Marl F with ochre inclusions.

*From: Arnold, Do. and J. Bourriau (Eds.), An Introduction to Ancient Egyptian Pottery (Mainz am Rhein, 1993), Fascicle 2, Ceramic Technology: Clays and Fabrics, by Hans Åke Nordström and J. Bourriau, 168-182. Aston, D., Egyptian Pottery of the Late New Kingdom and Third Intermediate Period (Twelfth-Seventh Centuries BC) (SAGA, 13; Heidelberg, Heidelberg Orientverlag, 1996), 9. Bietak, M., Tell el-Dab'a V. Wien (Österreichischen Akademie der Wissenschaften, 1991) 328. Cremonte, B., Non-local Pottery Fabrics from Tell el-Ghaba. A Preliminary Classification (to be published in Tell el-Ghaba II, Studies).

TABLE II: TELL EL-GHABA IMPORTED FABRIC TYPOLOGY. A BRIEF DESCRIPTION*

Fabric classification		Fabric description
North Sinai /South Palestine fabrics (II)	II.TG 08	Soft fabric. Inclusions: Ochre [2] small to very large, rounded. Sand [2] fine and medium. Black particles [1] small. Light brown particles [1] tabular and thin.
	II.TG 09	Soft fabric. Inclusions: Ochre [1] medium to very large. Sand [3] fine. Black particles [1] small. Some light brown large and rounded inclusions (clay nodules?). Whitish particles [1] fine, angular and tabular. Organic material [1] [1] small, rounded, calcinated.
	II.TG 10	Soft fabric. Inclusions: Ochre [1] small and rounded. Sand [3] fine to medium rounded vitreous and milky quartz. Black particles [1] small and rounded. Whitish particles [1] fine to large. Probable clay nodules and small rounded brown zones.
	II?TG 47	Hard fabric. Inclusions: Ochre [1] fine to medium, rounded. Sand [2] medium [1] coarse, vitreous and pinkish quartz, rounded. Limestone? [1] fine to coarse, rounded. Black particles [1] small and rounded. Whitish particles [1] fine to medium, rounded.
	II?TG 59	Medium hard fabric. Inclusions: Ochre [2] small to large, rounded. Sand [1] fine. Limestone [2] small, very scarce large and rounded. Black particles [1] small. Forams [1] small and medium. Mica [1] as muscovite points. Brown particles [1] large, rounded and tabular. Straw [1] as long and thin voids. Clay nodule: large and light brown.
Levantine fabrics (IV)	IV.TG 01	Medium hard fabric. Inclusions: Ochre [1] fine [1] coarse. Sand [2] fine. Limestone [2] fine, scarce medium and coarse zones. Black particles [1] fine. Forams [1] fine.
	IV.TG 03	Medium hard fabric. Inclusions: Ochre [1] fine to coarse. Sand [1] fine to medium, rounded and angular quartz. Limestone [1] fine [1] coarse and very coarse. Black particles [1] probably calcinated organic material. Forams [2].
	IV.TG 05	Hard fabric. Inclusions: Ochre [1] small. Sand [1] medium. Limestone [1] small [1] large. Black particles [1] small and medium. Forams [1].
	IV.TG 06	Medium hard fabric. Inclusions: Ochre [1] tiny. Sand [2] fine. Limestone [2] small and medium, rounded. Black particles [1] small. Forams [1] small.
	IV.TG 07	Hard fabric. Inclusions: Ochre [1] small and large. Sand [1] medium (vitreous quartz and reddish brown translucent particles). Limestone [2] small to large (oxidized edges). Black particles [1] medium. Forams [1]. Mica [1] probably muscovite. Straw: a large black and rectangular inclusion (4 mm) in the grey core.
	IV.TG 11	Medium hard fabric. Inclusions: Ochre [1] small [1] large. Sand [1] fine, quartz and scarce translucent red particles. Limestone [2] small and medium with oxidized edges. Black particles [1] small and medium, rounded.
	IV.TG 16	Low hardness fabric. Inclusions: Ochre [1] small and rounded. Limestone [1] small and rounded. Black particles [1] small and medium, rounded. Forams [1] small. Shell [1] small. Orange particles: [3] small to very large, tabular with angular edges, orange fine grained rock like shale with abundant iron oxides.
	IV.TG 17	Hard fabric. Inclusions: Ochre [1] small. Sand [1] fine and medium. Limestone [1] small to large. Black particles [1] tiny. Forams [1].

*From: Cremonte, B., Non-local Pottery Fabrics from Tell el-Ghaba. A Preliminary Classification (to be published in Tell el-Ghaba II, Studies).

Fabric classification		Fabric description
Levantine fabrics (IV)	IV.TG 18	Low hardness fabric. Inclusions: Sand [3] fine to coarse rounded vitreous quartz. Limestone [2] small to very large, angular and rounded (soft). Mica [1] tiny (as probable muscovite points). Some calcinated organic material (chaff?).
	IV.TG 19	Very hard fabric. Inclusions: Ochre [1] scarce and fine. Sand [1] fine. Rounded and some angular quartz. Limestone [2] small and medium, rounded and angular. Black particles [1] small to medium pebbles. Forams [1] very scarce and small.
	IV.TG 21	Medium hard fabric. Inclusions: Ochre [1] tiny. Sand [1] fine, angular vitreous quartz. Limestone [2] small to medium, rounded. Black particles [1] small and rounded. A few straw hues and probable shell.
	IV.TG 23	Medium hard fabric. Inclusions: Ochre [1] small and rounded. Sand [1] fine (vitreous rounded quartz). Limestone [2] small to large, rounded. The large ones, very scarce. Black particles [1] small and rounded. Red particles [1] small and angular. Forams [1]. Probably clay nodules.
	IV.TG 24	Medium hard fabric. Inclusions: Ochre [1] small to medium. Sand [1] fine to medium: milky quartz and tiny red translucent particles. Limestone [2] small and [2] large and very large. Black particles [1] small. Forams [1].
	IV.TG 25	Hard fabric. Inclusions: Ochre [1] small. Sand [1] fine to medium. Limestone [1] medium to large. Black particles [1] small and medium rounded pebbles. Forams [2] medium a very clear.
	IV.TG 29	Medium hard fabric. Inclusions: Ochre [1] fine and medium. Sand [2] fine (rounded vitreous and milky quartz). Limestone [1] fine. Black particles [1] fine. Forams [1]. One probable clay nodule or <u>grog</u> .
	IV.TG 31	Medium hard fabric. Inclusions: Ochre [1] small [1] medium, rounded. Sand [1] small and medium vitreous quartz. Limestone [2] small to large, rounded and angular. Black particles [1] small and medium, rounded and angular. Forams or shell [1].
	IV.TG 32	Very hard fabric. Inclusions: Ochre [1] small and rounded. Sand [1] fine, rounded vitreous quartz. Limestone [2] small and rounded. Black grit [1]. Forams [1]. Mica [1] as points of muscovite.
	IV.TG 36	Hard fabric. Inclusions: Ochre [2] small to large, rounded. One of them very large and tabular. Sand [1] fine to medium rounded vitreous quartz. Limestone [2] small to large, angular, very scarce rounded. Black particles [1] small to medium, angular and rounded.
	IV.TG 51	Hard fabric. Inclusions: Ochre [2] fine to coarse, rounded and tabular with tiny inclusions and forams inside. Sand [2] fine to medium (vitreous quartz). Limestone [2] fine and medium, rounded. Black particles [2] small, rounded, tabular and angular. One large and rounded black inclusion (burnt seed?). Forams or shell [1].
	IV.TG 52	Hard fabric. Inclusions: Ochre [2] fine to coarse, rounded and tabular with tiny inclusions and forams inside, coarse particles are very common. Sand [2] fine to medium (vitreous quartz). Limestone [2] fine and medium, rounded. Black particles [2] small, rounded, tabular and angular. Forams or shell [1].
	IV.TG 53	Medium hard fabric. Inclusions: Ochre [1] small [1] medium, rounded. Sand [2] fine [1] medium, rounded vitreous quartz. Limestone [1] small. Black particles [2] small [1] medium, rounded. Forams ? [1] small.
IV.TG 57	Medium hard fabric. Inclusions: Ochre [1] small and rounded. Sand [2] fine [1] medium, rounded vitreous quartz and scarce reddish translucent particles. Limestone [1] small and medium,	

Fabric classification		Fabric description
Levantine fabrics (IV)	IV.TG 57	rounded, tabular and angular. Black particles [1] small [1] medium, rounded and angular. Forams [1] small. Mica [1] fine (muscovite). Grey particles [1] small. Straw [1].
	IV.TG 61	Hard fabric. Inclusions: Ochre [3] fine to coarse, rounded with tiny inclusions inside. Some of them look like grog. Sand [2] fine to coarse rounded vitreous and milky quartz. Limestone [2] fine to coarse, rounded. Black particles [2] small and medium, translucent and rounded. Mica [1] as scarce points. Greyish particles [1] small. Probable forams.
(Phoenicians)	IV.TG 13 = Phoen.05	Hard fabric. Inclusions: Ochre [1] fine to medium. Sand [2] fine. Limestone [1] fine.
	IV.TG 22 = Phoen.04	Hard fabric. Inclusions: Ochre [1] fine and medium, rounded. Sand [1] fine to medium. Limestone [1] fine and rounded, medium very scarce. Black particles [1] fine and rounded. Mica [1] fine and very clear (muscovite). Forams [1] fine.
	IV.TG 35 = Phoen.01	Very hard fabric. Inclusions: Ochre [1] small. Sand [1] fine. Rounded vitreous quartz. Limestone [1] small and rounded. Black particles [1] small and rounded. Forams [1] small, very scarce. Mica [1] points of muscovite. Red particles [1] small and rounded.
	IV.TG 37 = Phoen.03	Medium hard fabric. Inclusions: Ochre [1] medium, angular. Sand [1] fine, rounded vitreous quartz. Limestone [2] fine to very large, rounded and angular. One tabular inclusion (6 mm). Black particles [1] small and rounded. Forams [2] small. Shell [1] small. Mica [1] points of muscovite. Black particles [1] medium and rounded, probably clay nodules.
	IV.TG 38 = Phoen.02	Medium hard fabric. Inclusions: Ochre [2] small and medium, rounded. Sand [2] fine, rounded vitreous quartz. Limestone [2] small to very large, rounded and sub-angular. Black particles [1] small and medium, rounded. Forams [1] small. Red particles [1] small and medium, rounded. Some light and rounded inclusions (clay nodules or organic material?). Distribution: non uniform.
Cypriote fabrics (VI)	VI.TG 04	Soft fabric. Inclusions: Ochre [1] fine to coarse, rounded and dark orange. Sand [1] fine. Limestone [1] small [1] medium to large. Black particles [1] small. Forams [1].
	VI.TG 40	Medium hard fabric. Inclusions: Ochre [1] fine and rounded. Sand [2] fine, rounded vitreous quartz. Limestone? [1] scarce and fine. Black particles [2] small. Mica [1] as tiny points. Distribution: uniform.
	VI.TG 42	Medium hard fabric. Inclusions: Sand [2] fine [1] medium and coarse, rounded and angular. Limestone? [1] medium and large, rounded. Black particles [1] small and medium, rounded. Brown particles [1] large and rounded. Mica [1]. Presence of salts.
	VI.TG 43	Medium hard fabric. Inclusions: Ochre [1] fine, rounded. Sand [2] fine to medium, vitreous quartz. Limestone [1] small and rounded. Black particles [1] fine to medium, rounded, angular and tabular. Mica?
	VI.TG 44	Soft fabric. Inclusions: Ochre [2] fine to large, rounded. Sand [1] fine to large, rounded vitreous quartz. Limestone [1] fine to large, rounded. Black particles [1] fine and rounded. Forams ? [1] fine. Mica?
	VI.TG 49	Quite soft fabric. Inclusions: Ochre [1] small to large, rounded. Sand [1] fine and medium rounded vitreous quartz. Limestone? small to large, rounded. Black particles [2] small to large, angular and rounded. Forams [1] fine. Whitish, brown and dark particles [2] fine to coarse and a probable clay nodule (light and rounded).
Aegean fabrics (VII)	VII.TG 39	Medium hard fabric. Inclusions: Ochre [1] very fine and rounded. Sand [2].

Fabric classification	Fabric description
Aegean fabrics (VII)	VII.TG 41 Medium hard fabric. Inclusions: Limestone [1] small and medium, rounded. Black particles [1] small, rounded.
	VII.TG 45 Hard fabric. Inclusions: Sand [1] very fine. Black particles [1] tiny and very scarce.
	VII.TG 46 (Chian) Medium hard fabric. Inclusions: Ochre [1] small and rounded. Sand [2] medium, vitreous quartz. Whitish particles [1] fine to large, rounded. Black particles [1] small and large, rounded. Mica [1] points of muscovite. One large and rounded yellowish brown particle (limestone?).
	VII.TG 48 (Samian) Medium hard fabric. Inclusions: Ochre [2] small (predominant) to large, rounded. Sand [1] fine [1] medium, rounded vitreous quartz. Limestone [2] small (predominant) to large, rounded. Black particles [2] small and rounded. Forams [1] very scarce and small. Mica [1] few points of muscovite.
	VII.TG 58 Hard fabric. Inclusions: Ochre [1] small to very large, rounded. Sand [2] fine to coarse (rounded vitreous quartz). Limestone [1] fine and rounded. Forams [1] small. Grey particles [2] fine to coarse, rounded and soft. Black particles [1] fine. One whitish translucent inclusion, some brown particles and a burnt organic inclusion.

Bibliography

I.- Stratigraphy (E. Crivelli Montero)

Coque, R., *Geomorfología* (Madrid, Alianza, 1984).

Gal, Z., and Y. Alexandre, *Horbat Rosh Zayit. An Iron Age Storage Fort and Village*. (Jerusalem, Israel Antiquities Authority, 2000).

Harris, E. C., *Principios de estratigrafía arqueológica* (Barcelona, Crítica, 1991).

Redmount, C. and R. Friedman, "Tales of a Delta Site: the 1995 Field Season at Tell el-Muqdam", *JARCE* 34 (1997), 57-83.

II.- Pottery and small finds (P. Fuscaldo)

`Abd el-Maksoud, M., "Fouilles récentes au Nord Sinaï, sur le site de Tell el-Herr. Première saison: 1984-1985", *CRIPEL* 8 (1986), 15-16.

`Abd el-Maksoud, M., "Une nouvelle forteresse sur la route d'Horus. Tell el-Hebua 1986 (Nord Sinaï)", *CRIPEL* 9 (1987), 13-16.

`Abd el-Maksoud, M., "Excavations on 'The Way of Horus'. Tell el-Heboua North Sinai (1986-1987)", *Proceedings of Colloquium The Archaeology, Geography and History of the Egyptian Delta in the Pharaonic Times, Wadham Collegue, 29-31 August, 1988, Discussions in Egyptology*, Special Number 1 (1989), 173-92.

`Abd el-Maksoud, M., "Project de sauvatage des sites antiques du Nord Sinaï", *Discussion in Egyptology* 24 (1992), 7-12.

`Abd el-Maksoud, M., *Tell Heboua (1981-1991). Enquête archéologique sur la Deuxième Période Intermédiaire et le Nouvel Empire à l'extrémité orientale du Delta* (Paris, Éditions Recherche sur les Civilisations, 1998).

Adams, W. Y., "Time, Types and Sites : The Interrelationship of Ceramic, Chronology and Typology", *BES* 8 (1986/87), 7-46.

Allen, S., "Spinning bowls: Representation and Reality", in J. Phillips et alii (ed.), *Ancient Egypt, the Aegean and the Near East. Studies in Honour of Martha Rhoads Bell* (San Antonio, Texas, 1997), vol. 1, 17-38.

Amiran, R., *Ancient Pottery of the Holy Land. From its beginnings in the Neolithic Period to the end of the Iron Age* (Jerusalem-Ramat Gan, Massada Press, 1969).

Andrews, C., *Ancient Egyptian Jewellery* (London, 1990).

Andrews, C., *Amulets of Ancient Egypt* (London, 1994).

Annis, M. B., L. Jacobs and R. F. Docter, "Archaic Commercial Amphorae from Cartaghe: a Technological Analysis", *Newsletter. Department of Pottery Technology* 13 (1995), 53-79.

Arnold, Do. and Bourriau, J. (eds.), *An Introduction to Ancient Egyptian Pottery*, Fasc.1 and

2 (Mainz am Rhein, Phillip von Zabern, 1993).

Artzy, M., "The Utilitarian 'Persian' Storejar Handles", *BASOR* 238 (1980), 69-73.

Aston, D. A., "Two Decorative Styles of the Twentieth Dynasty", *CCE* 3 (1992), 71-80.

Aston, D. A., *Egyptian Pottery of the Late New Kingdom and Third Intermediate Period (Twelfth-Seventh Centuries BC). Tentative Footsteps in a Forbidding Terrain* (SAGA, 13; Heidelberger, Heidelberger Orientverlag, 1996).

Aston, D. A., *Die Keramik des Grabungsplatzes QI. Teil 1: Corpus of Fabrics, Wares and Shapes* (Mainz am Rhein, Phillip von Zabern, 1998).

Aston, D. A., *Elephantine XIX. Pottery from the Late New Kingdom to the Early Ptolemaic Period* (Archäologische Veröffentlichungen, 95; Mainz, Phillip von Zabern, 1999).

Åström, P., *The Middle Cypriote Bronze Age*, in E. Gjerstad (ed.), *The Swedish Cyprus Expedition*, vol. IV, part 1, 1984.

Ayalon, E., "The Iron Age II Pottery Assemblage from Horvat Teiman (Kuntillet 'Ajrud) Pottery", *Tel Aviv* 22 (1995), 141-212.

von Beckerath, J., *Chronologie des pharaonischen Ägypten. Die Zeitbestimmung der ägyptischen Geschichte von der Vorzeit bis 332 v. Chr.* (Münchener Ägyptologische Studien, 46, herausgegeben von G. Burkard und D. Kessler; Mainz, 1998).

Ben-Shlomo, D., "The Iron Age Sequence of Tel Ashdod: a Rejoinder to 'Ashdod revisited' by I. Filkenstein and L. Singer-Avitz", *Tel Aviv* 30, No.1 (2003), 83-107.

Ben-Tor, A., *The Archaeology of Ancient Israel* (New Haven, Yale University Press [Tel Aviv]: Open University of Israel, 1992).

Ben-Tor, A., "The small finds", in A. Ben-Tor, Y. Portugali, M. Avissar, U. Baruch and M. Hunt, *Tell Qiri, a Village in the Jezreel Valley. Report of the Archaeological Excavations 1975-1977 (The Yoqne'am Regional Project)* (Qedem, Monographs of the Institute of Archaeology, The Hebrew University of Jerusalem, 24; Jerusalem, 1987), 236-243.

Bergoffen, C. J., "Overland Trade in Northern Sinai: The Evidence of the Late Cypriot Pottery", *BASOR* 284 (1991), 59-76.

Bieber, A. M., Jr., D. W. Brooks, G. Harbottle, and E. V. Sayre, "Application of Multivariate Techniques to Analytical Data on Aegean Ceramics", *Archaeometry* 18 (1976), 59-74.

Bietak, M., *Tell el Dab'a II* (Wien, Österreichischen Akademie der Wissenschaften, 1975).

Bietak, M., "Stratigraphie und Seriation. Arbeiten zur Erschliessung der relativen Chronologie in Ägypten", in *Festgabe H. Vetters* (Wien, 1985), 5-9.

Bikai, P., "The Late Phoenician Pottery Complex and Chronology", *BASOR* 229 (1978),

47-56.

Bikai, P., *The Phoenician Pottery of Cyprus* (Nicosia, 1987).

Bikai, P., "The Phoenicians and Cyprus", in V. Karageorghis (ed.), *Proceedings of the International Symposium Cyprus in the 11th Century B.C.* (Nicosia, 1994), 31-36.

Bourriau, J., "Processing Finds from Excavations: What does the Future Offers us?", in S. Schoske (ed.), *Akten des Vierten Internationalen Ägyptologischen Kongresses München 1985* (München, 1988), *BSAK* 1, 11-18.

Bourriau, J., "Imported Pottery in the Third Intermediate and Late Dynastic Periods from the Excavations 2000-2001", in U. Hartung, P. Ballet, F. Béguin, J. Bourriau, P. French, T. Herbich, P. Kopp, G. Lecuyot und A. Schimite, *Tell el-Fara'in- Buto* 8, *MDAIK* 59 (2003), 224-233.

Bourriau, J. and P.T. Nicholson, "Marl Clay Pottery Fabrics of the New Kingdom from Memphis, Saqqara and Amarna", *JEA* 78 (1992), 29-91.

Braun, E., "Iron Age II Burials and Archaeological Investigations at Horbat Menorim (El-Manara), Lower Galilee", *Atiqot* XLII (2001), 171 ff.

Brehme, S., M. Brönnner, V. Karageorghis, G. Plotz-Honster and B. Weisser, *Ancient Cypriote Art in Berlin* (Nicosia, 2001).

Breyer, F. A. K., "Psammetik II., der alte Haudegen- Zu einer soldatensprachlichen Wendung in der Shellal-Inschrift", *SAK* 30 (2002), 53 ff.

Briend, J. et Humbert, J. (eds.), *Tell Keisan (1971-1973), une cité phénicienne en Galilée* (Orbis Biblicus et Orientalis, Serie Archaeologica; Freiburg, 1980).

Brissaud, P-H. et alii, "Répertoire préliminaire de la poterie trouvée à San el Hagar", 1st. Part, *CCE* 1 (1987), 77-80; 2nd Part, Cahier de Tanis I (Memoires No. 75; Paris, 1987), 75-99.

Buhl, M. L., *Sukas VII: The Near East Pottery and Objects of the other Materials from the Upper Strata* (Copenhagen, 1983).

Bunimovitz, S. and Z. Lederman, "Tel Shemesh, 2001-2003", in *Notes and News*, *IEJ* 53 (2003), 233-237.

Cecchini, S. M., "Un bâtiment mystérieux sur l'acropole de Tell Afis", in P. Matthiae, A. Enea, L. Peyronel, F. Pinnock, (eds.), *Proceedings of the First International Congress on the Archaeology of the Ancient Near East, Rome, May 18th -23rd, 1998* (Roma, 2000), vol I, 199-212.

Chaaya, A., "L'évolution et le changement culturel à Tell 'Arqa après l'invasion de Tiglath-Pileser III (Niveaux 10-9)", in P. Matthiae, A. Enea, L. Peyronel, F. Pinnock, (eds.), *Proceedings of the First International Congress on the Archaeology of the Ancient Near East, Rome, May 18th -23rd, 1998* (Roma, 2000), vol I, 213-222.

Chapman, S., "A Catalogue of Iron Age Pottery from the Cemeteries of Khirbet Silm, Joya, Qrayé and Qasmieh of South Lebanon", *Berytus XXI* (1972), 55-194.

Chartier-Raymond, M. et C. Traunecker, "Reconnaissance archéologique à la pointe orientale du Delta. Campagne 1992", *CRIPEL* 15 (1993), 45-71.

Clairmont, Ch., "Greek pottery from the Near East", *Berytus II* (1954-1955), 1-34.

Cook, R., *Greek painted pottery* (Chicago, 1960).

Coulson, W.D.E., *Ancient Naukratis II. Survey at Naukratis and Environs. Part I, Survey at Naukratis* (Oxbow Monograph, 60; Oxford, Oxbowbooks, 1996).

Coulson, W.D.E. and A. Leonard, *Cities of the Delta I. Naukratis. Preliminary Report on the 1977-78 and 1980 Seasons* (Malibu, Undena Publications, 1981).

Curtis, R. I., *Ancient Food Technology* (Technology and Change in History, 5; Leiden, 2001).

Davies, W.M., "Ancient Naukratis and the Cypriots in Egypt", *GM* 35 (1979), 13-23.

Dayagi-Mendels, M., *The Akhziv Cemeteries. The Ben-Dor Excavations, 1941-1944* (IAA Report, No. 15; Jerusalem, 2002).

de Salvia, F., "The Cypriotes in the Saite Nile Delta: the Cypro-Egyptian Religious Syncretism", in A. Nibbi (ed.), *Proceedings of the Colloquium 'The Archaeology, Geography and History of the Egyptian Delta in Pharaonic Times'. Wadham College, 29-31 August, 1988* (*Discussions in Egyptology*, Special Number 1, 1989), 81-118.

Dorman, P. F., *Faces in Clay. Technique, Imagery and Allusion in a Corpus of Ceramic Sculpture from Ancient Egypt* (Münchener Ägyptologische Studien, 52; Mainz am Rhein, 2002).

Dupont, P. et J. C. Goyon, "Amphores grecques archaïques de Gurna: à propos d'une publication récente". *Atti VI Congresso Internazionale di Egittologia* (Torino, 1992), 153-166.

El-Taba'i, A. et J.-Y. Carrez-Maratray, "Aux portes de Péluse: Farama Ouest Campagne de Sauvetage 1992", *CRIPEL* 15 (1993), 111-118.

Eph'al, I., "Nebuchadnezzar the Warrior", *IEJ* 53, No. 2 (2003), 178-191.

Falkovitch, J., "L'usage des amulettes égyptiennes", *BSEG* 16 (1992), 19-26.

Fantalkin, A., "Mezah Hashavyahu: its Material Culture and Historical Background", *Tel Aviv* 28, No.1 (2001), 3-165.

Faust, A., "Burnished Pottery and Gender Hierarchy in Iron Age Israelite Society", *JMA* 15.1 (2002), 53-73.

Festuccia, S., "The Moulds of Ebla, Morphology and Archaeological Contexts", in P.

Matthiae, A. Enea, L. Peyronel, F. Pinnock (eds.), *Proceedings of the First International Congress on the Archaeology of the Ancient Near East, Rome, May 18th –23rd, 1998* (Roma, 2000), vol I, 421-436.

Filkenstein, I., and L. Singer-Avitz, “Ashdod revisited“, *Tel Aviv* 28 (2001), 231-259.

Finkelstein, I., O. Zimhoni and A. Kafri, “The Iron Age Pottery Assemblages from Areas F, K and H and their Stratigraphic and Chronological Implications“, in Finkelstein, I., D. Ussishkin, and B. Halpern (eds.), *Megiddo III. The 1992-1996 Seasons* (Emery and Claire Yass Publications in Archaeology, 1998), 244-324.

Forbes, R. J., “*Metallurgy in Antiquity. A Notebook for Archaeologist and Technologists*” (Leiden, 1950).

French, P., “Late Dynastic pottery from the Berlin/Hannover Excavations at Saqqarah”, *MDAIK* 44 (1988), 79-80.

French, P., “A Preliminary Study of Pottery in Lower Egypt in the Late Dynastic and Ptolemaic Periods”, *CCE* 3 (1993) [Ateliers de potiers et productions céramiques en Égypte], 83-93.

French, P. and H. Ghaly, “Pottery chiefly of the Late Dynastic Period (Saqqarah)”, *CCE* 2 (1991), 93-123.

Fuscaldo, P., S. Basílico, B. Cremonte and S. Lupo, “A Preliminary Report on the Pottery from Tell el-Ghaba, a Saite Settlement in North Sinai”, in Z. Hawass (ed.), *Egyptology at the Dawn of the Twenty-first Century. Proceedings of the 8th. International Congress of Egyptologist, Cairo, March 23rd –April 3rd, 2000* (The American University in Cairo, Cairo, 2002), vol. 1, Archaeology, 189-194.

Gal, Z., “Horbat Rosh Zayit and the Early Phoenician Pottery”, *Levant* XXIV (1992), 173-186.

Gal, Z., “The Diffusion of Phoenician Cultural Influence in Light of the Excavations at Hurvat Rosh Zayit”, *Tel Aviv* 22 (1995), 89-93.

Gardiner, A.H., “The Ancient Military Road Between Egypt and Palestine”, *JEA* 6 (1920), 99-116.

Gershuny, L., “Pottery from Area E”, in A. Kempinski (ed.), *Excavations at Kabri. Preliminary Report of 1986 Season* (Tel Aviv, 1987), 66-69.

Geva, S., “Archaeological Evidence from the Trade between Israel and Tyre?”, *BASOR* 248 (1982), 69-72.

Gjerstad, E., *The Cypro-Geometric, Cypro-Achaic and Cypro-Classical Periods (The Swedish Cyprus Expedition, ed. by E. Gjerstad; Stockholm, 1984), vol. IV, part. 2.*

Goedicke, H., “The Campaign of Psammetik II against Nubia”, *MDAIK* 37 (1981), 187-198.

Goren, Y., "Petrographic Analyses of Horvat Teiman (Kuntillet 'Ajrud) Pottery. Appendix A", *Tel Aviv* 22 (1995), 206-207.

Goren, Y., E. Oren and R. Feinsein, "The Archaeological and Ethnoarchaeological Interpretation of a Ceramological Enigma: Pottery Production in Sinai (Egypt) during the New Kingdom". *KUHAA Konferens*, 34 (Stockholm, 1995), 101-112.

Gratin, B., "Tell el-Herr (Nord Sinaï). Étude stratigraphique de la céramique", *CRIPPEL* 18 (1996), 71-105.

Hamroush, Hany A., "Pottery Analysis and Problems in the Identification of the Geological Origins of Ancient Ceramics", *CCE* 3 (1992), 39-51.

Hamza, O., "Quedua", *CCE* 5 (1997), 81-102.

Hancock, R., S. Aufreiter and I. Elsokkary, "Nile Alluvium: Soils and Ceramics", *BES* 8 (1986/87), 61-71.

Haritz, J.- M. Rodziewicz, Syene, "Review of the Urban Remains and its Pottery", *MDAIK* 50 (1994), 115 ff.

Herr, L., "Iron II Palestine: Emerging Nations", *BA* 60, part 3 (1997), 114-183.

Hoffmeier, J. K., and M. `Abd el-Maksoud, "A New Military Site on "The Ways of Horus"-Tell el-Borg 1999-2001: a Preliminary Report", *JEA* 89 (2003), 109-197.

Holladay, E. J. S., *Cities of the Delta III. Tell el-Maskhuta. Preliminary Report on the Wadi Tumilat Project 1978-1979* (Malibu, Undena Publications, 1982).

Holthoer, R., *New Kingdom Pharaonic Sites. The Pottery* (T. Säve-Söderbergh, ed., *The Scandinavian Joint Expedition to Sudanese Nubia*, 5:1; Uppsala 1997).

Hope, C. A., "Kegs and Flask from the Dakhle Oasis", with an Appendice by M.A.J. Eccleston, O.E. Kaper, S. Marchand, and D. Darnell, *CCE* 6 (2000), 189-234.

Hunt, M., "The Iron Age", in A. Ben-Tor, Y. Portugali, M. Avissar, U. Baruch and M. Hunt, *Tell Qiri, a Village in the Jezreel Valley. Report of the Archaeological Excavations 1975-1977 (The Yoqne'am Regional Project)* (Jerusalem, 1987. Qedem, Monographs of the Institute of Archaeology, The Hebrew University of Jerusalem, 24), 139-223.

Jacquet-Gordon, H., "A Tentative Typology of Egyptian Bread Moulds", in Do. Arnold (ed.), *Studien zur altägyptischen Keramik* (Mainz am Rhein, 1981), 11-24.

Jaeger, B., *Essai de classification et datation des scarabées Menkheperre* (Orbis Biblicus et Orientalis, Serie Archaeologica 2; Fribourg, 1982).

James, F.W., *The Iron Age at Beth Shan* (Philadelphia, 1966).

Jones, R. F. J., "Why Pottery?" in M. Millet (ed.), *Pottery and the Archaeologist* (Institute of Archaeology at the University of London, Occasional Publication No. 4; London, 1979), 1-5.

Keel, O., *Corpus der Stempelsiegel-Amulette aus Palästina/Israel, von den Anfängen bis zur Perserzeit*. Einleitung (Orbis Biblicus et Orientalis 10, Serie Archaeologica; Göttingen, 1995). Katalog Band I: *Von Tell Abu Farag bis 'Attil*, unter Mitarbeit von D. Ben-Tor, B. Jaeger, A. Jäkle, K. Jarosh, H. Keel-Leu, C. Mlinar und C. Uehlinger, with three contributions by B. Brandl (Orbis Biblicus et Orientalis, 13, Serie Archaeologica; Göttingen, 1997).

King, R. H., D. W. Rupp, and L. W. Sorenson, "A Multivariate Analysis of Pottery from Southwestern Cyprus using Neutron Activation Analysis Data", *JAS* 13 (1986), 361-374.

Kitchen, K. A., *The Third Intermediate Period in Egypt 1100-650* (Warmister, Aris & Phillips, 1972).

Lavenex Vergès, F., *Bleus égyptiens. De la pâte auto-émailée au pigment bleu synthétique* (Louvain - Paris, Éditions Peeters, 1992).

Lilyquist, C. and R. H. Brill, with M. T. Wypyski, and contributions by H. Shirahata, R. J. Koestler, and R. D. Vocke Jr., *Studies in Early Egyptian Glass* (New York, The Metropolitan Museum of Art, 1993).

Littauer, M. A. and J. H. Crouwel, *Wheeled Vehicles and Ridden Animals in the Ancient Near East* (Handbuch der Orientalistik, herausgegeben von B. Spuler, Siebente Abteilung, Kunst und Archäologie, herausgegeben von J. E. van Lohuizen-de Leeuw, Erster Band, Der Alte Vordere Orient, Zweiter Abschnitt, Die Denkmäler, herausgegeben von B. Hrouda., B. Vorderasien, Lieferung 1). Chapter Nine: Earlier First Millennium B.C. (ca. 1000-600 B.C.); Leiden/Köln, 1979), 99-143.

Lohwasser, A., "Eine phönizische Bronzeschale aus dem Sudan", *Ä&L* XII (2002), 221-234.

López Grande, M. J., F. Quesada Sanz, y M. A. Molinero Polo, *Excavaciones en Ehnasya El Medina (Heracleópolis Magna)* (Madrid, 1995), vol. 2.

Lupo S. and S. Basílico, "On the Chronology of Tell El-Ghaba, North Sinai", *BACE* 13 (2002), 127-134.

Maeir, A.M., "The Relations between Egypt and the Southern Levant during the Late Iron Age. The Material Evidence from Egypt", *Ä&L* XII (2002), 235-246.

Majcherek, G. and `Abd el-Aziz El-Shennawi, "Research on Amphorae Production on the Northwestern Coast of Egypt", *CCE* 3 (1992), 130-136.

Marcolongo, B., "Évolution du paléo-environnement dans la partie orientale du Delta du Nil depuis la transgression flandrienne (8000 BP) par rapport aux modèles de peuplement anciens", *CRIPEL* 14 (1992), 23-31.

Mason, R., "Analytical Techniques in Near Eastern Archaeology: Materials and the Scanning Electron Microscope", *BA* 58, No. 4 (1995), 237.

Na'aman, N., "The Broke of Egypt and Assyrian Police on the Border of Egypt", *Tel Aviv* 6 (1979), 68-90.

Na'aman, N., "Population Changes in Palestine following Assyrian Deportations", *Tel Aviv* 20 (1993), 104-124.

Na'aman, N., "Israel, Edom and Egypt in the 10th Century B.C.E.", *Tel Aviv* 19 (1992), 71-93.

Na'aman, N., "An Assyrian Residence at Raman Rahel?", *Tel Aviv* 28 (2001), 260-280.

Naveh, J., "The excavations at Mesad Hashavyahu: Preliminary Report", *IEJ* 12 (1962), 89-113.

Newbery, P.E., *Ancient Egyptian Scarabs* (Chicago, 1905/1979).

Nicholson, P.T., "The Pottery Workshop at Q48.4 at Tell El-Amarna", *CCE* 3(1992), 61-70.

Nicholson, P.T. and I. Shaw (ed.), *Ancient Egyptian Materials and Technology* (Cambridge University Press, 2000).

Niemeir, W.D., "The Greek Pottery", in A. Kempinski (ed.), *Excavations at Kabri. Preliminary Report of 1989 Season* (Tell Kabri Expedition; Tel Aviv, 1990), 4, XXXIV-XXXIX.

Nordström, H. Å. and J. Bourriau, "Ceramic Technology: Clays and Fabrics", in D. Arnold and J. Bourriau (eds.), *An Introduction to Ancient Egyptian Pottery* (Deutsches Archäologisches Institut Abteilung Kairo, Sonderschrift 17; Mainz am Rhein, 1993), fascicle 2, 145-190.

Oren, E. D., "The Overland Route between Egypt and Palestine in the Early Bronze Age (Preliminary Report)", *IEJ* 23 (1973), 198-205.

Oren, E. D., "Migdol: A New Fortress on the Edge of the Eastern Nile Delta", *BASOR* 256 (1984), 7-44.

Oren, E. D., "Northern Sinai Survey", in E. Stern, A. Lewinson-Gilboa and J. Aviram (eds.), *The New Encyclopedia of Archaeological Excavations in The Holy Land*, vol. 4 (Jerusalem, Israel Exploration Society, 1985), 1386-1396.

Oren, E. D., "The 'Ways of Horus' in North Sinai", in A. F. Rainey (ed.), *Egypt, Israel and Sinai. Archaeological and Historical Relationships in the Biblical Period* (Tel Aviv, Tel Aviv University, 1987), 69-119.

Padró, J., "Découverte de céramiques phéniciennes à Héracléopolis Magna (Égypte)", *Atti del II Congresso Internazionale di Studi Fenici e Punici* (Roma, 1991), vol. 3, 1103-1108.

Paice, P., "A Preliminary Analysis of Some Elements of the Saite and Persian Period Pottery at Tell el-Maskhuta", *BES* 8 (1986/87), 95-107.

Papadopoulos, J. K., "From Macedonia to Sardinia: Problems in Iron Age Aegean Chronology, and Assumptins of Greek Maritime Primacy", in M.S. Balmuth and R. H. Tykot, (eds.), *Sardinian and Aegean Chronology. Towards the Resolution of Relative and*

Absolute Dating in the Mediterranean. Proceedings of the International Colloquium "Sardinian Stratigraphy and Mediterranean Chronology", Tufts University, Medford, Massachusetts, March 17-19, 1995 (Studies in Sardinian Archaeology, V; Oxbow Books, 1998), 363-369.

Petrie, W. M. F., *Naucratis I (1984-5)* (Londres, Egypt Exploration Fund, 1886).

Petrie, W. M. F., *Tanis II, including Nebesheh and Defenneh (Tahpanhes)* (Londres, Egypt Exploration Fund, 1888).

Petrie, W. M. F., *Tools and Weapons* (Warmister, 1917/ Encina, CA, 1974).

Redmount, C. A., *On an Egyptian Asiatic Frontier: an Archaeological History of the Wadi Tumilat* (Ann Arbor, Michigan, 1989), vol. I-IV.

Redmount, C. A., "Of Silts and Marls and Mixes: Analysis of Modern Egyptian Pottery", *GM* 147 (1995), 93-101.

Redmount, C. A. and R. Friedman, "The 1993 Field Season of the Berkeley Tell el-Muqdam Project: Preliminary Report", *Newsletter of the ARCE* 164 (1994), 1-10.

Rehren, T. and E. Pusch, "New Kingdom Glass-melting Crucibles from Qantir-Pi Ramesses", *JEA* 83 (1997), 127 ff.

Rice, P.M., *Pottery Analysis: A Sourcebook* (Chicago, 1987).

Rodziewicz, M., "Field Notes from Elephantine on the Early Aswan Pink Clay Pottery", *CCE* 3 (1992), 103-107.

Rzóska, J., "Delta Lakes of Egypt", in J. Rzóska, (ed.), *The Nile, Biology of an Ancient River* (The Hague, 1976), 309-312.

Sagona, A. C., "Levantine Storage Jars of the 13th to 4th Century BC", in *Opuscula Atheniensi* 14 (1982), 73-110.

Salles, J.-F., *La nécropole "K" de Byblos* (Mémoires No. 2; Paris, 1980).

Sauneron, S., "Le monde du magicien égyptien", in D. Bernot, et al. (eds.), *Le monde du sorcier* (Sources Orientales, 7; Paris, 1966), 27-65.

Sauneron, S. et J. Yoyotte, "La campagne nubienne de Psammétique II et sa signification historique", *BIFAO* 50 (1952), 157-207.

Sebbane, M., O. Ilan, U. Avner and D. Ilan, "The Dating of Early Bronze Age Settlements in the Negev and Sinai", *Tel Aviv* 20 (1993), 41-54.

Segal, I., L. Halicz, and A. Kamenski, "The Metallurgical Remains from Ashqelon, Afridar- Areas E, G and H", *Atiqot* 45 (The Early Bronze Age Site at Ashqalon, Afridar, 2004), 311-330.

Seiler, A., *Hebua I. Second Intermediate Period and Early New Kingdom Pottery*, *CCE* 5

(1997), 23-33.

Shamir, O., "The Spindle Whorls from Ashqalon, Afridar-Area E", *'Atiqot* 45 (The Early Bronze Age Site at Ashqalon, Afridar, 2004), 97-100.

Shea, W. H., "A Date for the Recently Discovered Eastern Canal of Egypt", *BASOR* 226 (1977), 31-38.

Sorensen, L. W., "Travelling Pottery Connections between Cyprus, the Levant and the Greek World in the Iron Age", in S. Swiny, R. L. Hohlfelder, H. Wylde Swiny (eds.), *Res Maritimae. Cyprus and the Eastern Mediterranean from Prehistory to Late Antiquity. Proceedings of the Second International Symposium, "Cities on the Sea", Nicosia, Cyprus, October 18th-22nd, 1994* (American Schools of Oriental Research. Archaeological Reports. Cyprus American Archaeological Research Institute Monograph Series; Atlanta, Georgia, 1997), vol. 1, 285-299.

Spalinger, A., "Egypt and Babylonia: A Survey (c. 620 B.C.-550 B.C.)", *SAK* 5 (1977), 221-244.

Steel, L., "Pottery Production in Cyprus in the Eleventh Century B.C.", in V. Karageorghis (ed.), *Proceedings of the International Symposium Cyprus in the 11th Century B.C* (Nicosia, 1994), 239-246.

Steel, L., "Consuming Passions: A Contextual Study of the Local Consumption of Mysenaean Pottery at Tell el-'Ajjul", *JMA* 15.1 (2002), 25-51.

Stern, E., *Material Culture from the Land of the Bible in the Persian Period 538-332 BC* (Jerusalem, Israel Exploration Society, 1973).

Stern, E., *The Beginning of the Greek Settlement in Palestina in the Light of the Excavations at Tel Dor (Recent Excavations in Israel. Studies in Iron Age Archaeology*, ed. by S. Gitin, and W. G. Dever; Winona Lake, 1989), 107-124.

Strange, S., "A Proposal for a New Periodization for the Bronze and Iron Ages in the Southern Levant (Jordan, Palestine and Israel)", in P. Matthiae, A. Enea, L. Peyronel, F. Pinnock (eds.), *Proceedings of the First International Congress on the Archaeology of the Ancient Near East, Rome, May 18th-23, 1998* (Roma, 2000), vol II, 1571-1577.

Ulreich, H., M. A. Negrete, E. Puch und L. Perdigones, "Cerro del Prado. Die Ausgrabungen 1989 im Schutthang der phönizischen Ansiedlung an der Gradaranque-Mündung", *MM* 31 (1990), 194-250.

Valbelle, D., "La (les) route(s)-d'Horus", in J.L. Chappaz et S. Poggia (eds.), *Hommages à Jean Leclant* (Paris, 1994), vol. 4, 379-386.

Valbelle, D., F. Le Saout, M. Chartier-Raymond, M. Abd el-Samie, C. Traunecker, G. Wagner, J.-Y. Carrez-Maratray, P. Zignani "Reconnaissance archéologique à la pointe orientale du Delta. Rapport préliminaire sur les saisons 1990 et 1991", *CRIPPEL* 14 (1992), 11-22.

Veldhuijzen, H. A., "The First Iron Smelting Site in the Levant at Tell Hammeh, Jordan".

Paper presented at the *4ICAANE*, Berlin, 2004.

Veniale, F., "Raw Materials and Manufacturing Processes in Ancient Ceramic Artefacts", in F. Burragato, O. Grubessi and L. Lazzarini (eds.), *First European Workshop on Archaeological Ceramics* (Rome, 1994), 55-72.

Vitto, F., "An Iron Age Burial Cave in Nazareth", *'Atiqot XLII* (2001), 159 ff.

Waldbaum, J., "Early Greek Contacts with the Southern Levant ca. 1000-600 B.C.: The Eastern Perspective", *BASOR* 293 (1994), 53-93.

Wimmer, S., "(No) more Egyptian Temples at Canaan and Sinai", in I. Shirun-Grumach (ed.), *Jerusalem Studies in Egyptology* (Wiesbaden, 1998), 97-111.

Yardenna, A., "The 'Hippo' Jar and other Storage Jars at Hurvat Rosh Zayit", *Tel Aviv* 22 (1995), 77-88.

Zemer, A., *Storage Jars in Ancient Sea Trade* (Haifa, 1978).

Zimhoni, O., "The Iron Age Pottery from Tel Jezreel. An Interim Report", *Tel Aviv* 19 (1992), 57-70.

Zimhoni, O., *Studies in the Iron Age Pottery of Israel. Typological, Archaeological and Chronological Aspects* (Institute of Archaeology at Tel Aviv University, Occasional Publications No. 2, ed. by L. Singer-Avitz, and D. Ussishkin; Tel Aviv, 1997).

Abbreviations used in the Bibliography

Ä&L: *Ägypten und Levante*, International Journal for Egyptian Archaeology and Related Disciplines, Vienna.

'Atiqot: Journal of the Israel Antiquities Authority, Jerusalem.

ARCE: *American Research Center in Egypt*, Cairo.

Archaeometry: Oxford, UK.

BA: *Biblical Archaeologist* (now *Near Eastern Archaeology*), New Haven.

BACE: *Bulletin of the Australian Centre of Egyptology*, Sydney.

BASOR: *Bulletin of the American Society for Oriental Research*, New Haven.

BCE: *Bulletin de Liaison du groupe international d'étude de la céramique égyptienne*, Cairo

Berytus: *Journal of the Faculty of Arts and Sciences, The American University of Beirut*.

BES: *Bulletin of the Egyptological Seminar*, New York.

BIFAO: *Bulletin de l'Institut Français d'Archéologie Orientale*, Cairo.

BSAK: *Studien zur Altägyptische Kultur, Beiheft*, Hamburg.

BSEG: *Bulletin de la Société d'Égyptologie Genève*, Geneva.

CCE: *Cahiers de la Céramique Égyptienne*, Cairo.

CRIPPEL: *Cahiers de Recherches de l'Institut de Papyrologie et d'Égyptologie de Lille*, Lille.

GM: *Göttinger Miszellen*, Göttingen.

IAA: *Israel Antiquities Authorities*, Jerusalem.

IEJ: *Israel Exploration Journal*, Jerusalem.

JARCE: *Journal of the American Research Center in Egypt*, Boston.

JAS: *Journal of Archaeological Science*, Nottingham.

JEA: *Journal of Egyptian Archaeology*, London.

JMA: *Journal of Mediterranean Archaeology*, Ann Arbor.

KUHAA: *Kungl. Vitterhets Historie och Antikvitets Akademien*, Stockholm.

Levant: *Annual of the Council for British Research in the Levant*, London.

MDAIK: *Mitteilungen des Deutschen Archäologischen Instituts, Abt. Kairo*, Wiesbaden – Mainz.

MM: *Madrider Mitteilungen*, Mitteilungen des Deutschen Archäologischen Instituts, Abt. Madrid, Mainz.

REE: *Revista de Estudios de Egiptología*, Buenos Aires.

SAGA: *Studien zur Archäologie und Geschichte Altägyptens*, Heidelberger.

SAK: *Studien zur Altägyptische Kultur*, Hamburg.

Tel Aviv: *Journal of the Institute of Archaeology*, Tel Aviv University, Tel Aviv.

TELL EL-GHABA I

Catalogue

Stratigraphy and Archaeological Material recovered from Tell el-Ghaba

by Eduardo Crivelli Montero and Perla Fuscaldo

PART I: AREA I

Abstract: Area I, located in the central-south of the Tell ([Plan I](#)), was selected for the beginning of the fieldwork because the rather thin sand cover allowed area excavation without the need to employ too much manpower. Other parts of Tell el-Ghaba are covered by a thick sheet of shifting sand and of some dunes. Moreover, the inspectors of the SCA had commented that some time ago, local Bedouins had plundered tombs in this general area. In fact, no burials were found by the Argentine Mission in the 250 m² which were exposed.

The stratigraphy is described from below up to the surface ([Graphic I](#)).

The first occupations took place on wet, clayey ground, as indicated by the laminated stratification and also by a sherd pavement (Level I). Some washed out burn debris indicates that the settlement extended outside the excavated area. Two flimsy structures, Buildings A and G, were erected afterwards (Level II). Building A (which was found thoroughly burnt) had reed walls and was roofed. Structure G was perhaps no more than a briefly utilized circular tent. After a period of accumulation of debris coming from neighbouring activity areas (Level III), multi-roomed Building B was built with mud bricks and eventually refurbished (Level IV). After its abandonment, a workshop area occupied the southern part of the Area (Level V). Violent destruction and fire almost levelled this, another, parts of the Tell –and others (Level VI). Afterwards, only some fishermen seem to have frequented the place.

LEVEL I: Strata below Building A and Structure G

1.- Stratigraphy

The sterile sediment underlying the archaeological sequence in Area I is plastic, rich in clay, and seems to have formed in a very wet medium: some lamination is apparent and at least in parts it can be described as a gley. It resembles the bed of the Eastern Lagoon, which is a *sebja*.²⁷ This sediment (sandy clay) has been examined in two test pits, respectively in BA/42 and BB/41. In BA/42, L0112 was very wet sandy clay, to the point that it could not be sieved. Instead, it was spread on the sieve and searched (unsuccessfully) for cultural items. In November 2nd, 1995, water table was found at 11.85 m below datum.²⁸ In BB/41, yellowish sandy clay L0379 was archaeologically sterile. In October 8th, 1999, it was tested down to 11.10 m from datum without reaching water table.

Overlying sandy clay L0375 is hard, difficult to excavate and very scarce in cultural remains. In Squares BB/41 and BB/42 it had been cut in antiquity by many criss-crossing ditches or furrows. Although these ditches follow different directions, several of them meet roughly at right angles, strongly suggesting that they are the foundation trenches of flimsy structures. A second reason for this interpretation is the fact that both Building A and Building B had the same alignment as some of these ditches (that is, WNW-ESE and/or NNE-SSW). As for the function of these postulated constructions, the abundance of fish remains in the fill of the ditches (unified as **L0371**)²⁹ strongly points to fishermen's huts and not to dens. Several hearths were also found (L0370, **L0372**; L0373; L0376), suggesting the beginning of a more or less regular occupation of this part of the site. Immediately west of hearth L0370 (120 cm wide), a lens 54 x 30 cm in diameter, formed

²⁷A *sebja* is a closed, flat and very brackish depression, devoid of vegetation (Coque, *Geomorfología*, 231-234).

²⁸ Datum was fixed at 10 m above the level of the SW peg of Square BA/41.

²⁹ The locus number in **bold** and *cursive* indicates that the recovered archaeological material is described after the stratigraphy of the corresponding level.

by a matrix of fish bones, was found. Between hearths L0372 and L0373, two positive features built of the same clayey sediment (*tina*) were left standing; two experienced workers interpreted them as accessories to the hearths; specifically, supports for pottery. They may have also served as seats.

Now charcoal and other organic remains are more common and the fill turns softer and less clayey.

In the eastern half of BB/41, the remains of a pavement (L0366) formed with sherds was found. Although such features are commonly found in both in Near Eastern and Egyptian archaeology³⁰ and this one is badly preserved (it has been cut by four ditches), it is the only example known at the moment in Tell el-Ghaba and was cleaned, documented and left in place.

The levels affected by the criss-crossing trenches are covered by sand L0266, which fills some of them. L0266 is, in its turn, cut by two major features, Building A and Structure G (Graphic I).

2.- Archaeological material

L0371 (Fig. 1)

I.- Pottery

a) Egyptian pottery

Nile silt clay

Fine ware

No. 1: bowl (Fig. 1:1), Inv. No. P1211A (Drawing No. 0525)

RP	Nile B ₂	W ₂	---	ox.	2-3
----	---------------------	----------------	-----	-----	-----

Rim sherd; incurved rim. Rd: 16.00 cm 3/32; Wd: 0.55 cm; H₁: 3.80 + x cm. Surface colour: 10R 5 /6 red slip. Break: 7.5YR 6/2 pinkish grey core; 2.5YR 6/6 red oxidation zones. Surface treatment: burnished. *Find No. 086.*

Household ware

No. 2: carinated bowl (Fig. 1:1), Inv. No. C-0628 [010]

Uncoated	Nile B ₂	W ₂
----------	---------------------	----------------

Rim sherd; carinated walls; vertical direct rim. Rd: 18.00 cm 1/16; Wd: 0.50 cm; H₁: 2.50 + x cm; throwing lines inside; smoothed on the wheel; eroded; salt incrustated.

No. 3: deep bowl (Fig. 1:1), Inv. No. P1209A (Drawing No. 0935)

Uncoated	Nile B ₂	W ₂ + Ha ₂	---	ox.	2
----------	---------------------	----------------------------------	-----	-----	---

Rim sherd; direct rim. Rd: 10.00 cm 1/3; Wd: 0.30 cm; H₁: 2.30 + x cm. Surface colour: 2.5YR 6/6 light red. Break: 2.5YR 3/1 dark reddish grey core; 2.5YR 6/6 light red oxidation zones. Decoration: modelled decoration applied on the rim. Surface treatment: smoothed.

No. 4: cup, Inv. No. C-0628 (2) [001]

Uncoated	Nile B ₁	W ₂	base finished on the wheel
----------	---------------------	----------------	----------------------------

Base fragment; pointed base. Wd: 0.35-0.70 cm; H₁: 3.50 + x cm; throwing lines inside; smoothed on the wheel; eroded. Another, Nile B₂, a base.

No. 5: jar (Fig. 1:1), Inv. No. C-0628 [001]

Uncoated	Nile B ₂	W ₂
----------	---------------------	----------------

³⁰ An example in the Persian Period is Tell el-Muqdam. Redmount and Friedman, *JARCE* 34, 65 and Fig. 4.

Rim sherd; vertical direct rim. Rd: 10.00 cm 1/4; Wd: 0.55 cm; H₁: 4.50 + x cm; throwing lines inside; smoothed on the wheel; eroded.

No. 6: jar (Fig. 1:1), Inv. No. C-0628 [002]

Uncoated	Nile B ₂	W ₂
----------	---------------------	----------------

Rim sherd; slightly inverted direct rim. Rd: 12.00 cm 5/32; Wd: 0.55 cm; H₁: 5.15 + x cm; throwing lines inside; smoothed on the wheel; salt incrustated inside.

No. 7: jar, Inv. No. C-0628 [014]

Uncoated	Nile B ₂	Ha ₂
----------	---------------------	-----------------

Handle fragment; loop handle; Hd: 3.50 x 2.00 cm; 1; single strap; oval in section; eroded.

No. 8: storage jar (Fig. 1:1), Inv. No. C-0628 [004]

Uncoated	Nile B ₂	W ₂
----------	---------------------	----------------

Rim sherd; inverted articulated interior and exterior rim; rolled lip. Rd: 20.00 cm 3/32; Wd: 1.00 cm; H₁: 5.60 + x cm; throwing lines inside; smoothed on the wheel; eroded.

No. 9: storage jar (Fig. 1:1), Inv. No. C-0628 [005]

Uncoated	Nile B ₂	W ₂
----------	---------------------	----------------

Rim sherd; inverted flattened direct rim. Rd: 20.00 cm 1/8; Wd: 0.90 cm; H₁: 5.50 + x cm; throwing lines inside; smoothed on the wheel; eroded.

No. 10: storage jar (Fig. 1:2), Inv. No. C-0628 [006]

Uncoated	Nile B ₂	W ₂
----------	---------------------	----------------

Rim sherd; inverted articulated interior and exterior rim; round lip. Rd: 20.00 cm 1/16; Wd: 0.85 cm; H₁: 3.90 + x cm; throwing lines inside; smoothed on the wheel; eroded.

No. 11: storage jar (Fig. 1:2), Inv. No. C-0628 [008]

Uncoated	Nile C ₁	W ₂
----------	---------------------	----------------

Rim sherd; inverted articulated interior and exterior rim; modelled lip. Rd: 24.00 cm 1/16; Wd: 1.40 cm; H₁: 3.90 + x cm; throwing lines inside; smoothed on the wheel; eroded.

No. 12: storage jar (Fig. 1:2), Inv. No. C-0628 [009]

Uncoated	Nile C ₂	W ₂
----------	---------------------	----------------

Rim sherd; everted articulated interior and exterior rim; modelled lip. Rd: 24.00 cm 1/8; Wd: 1.00 cm; H₁: 3.90 + x cm; throwing lines inside; smoothed on the wheel; overfired.

Pottery with special functions

No. 13: bakery tray, Inv. No. C-0628 [007]

Uncoated	Nile C ₂	W ₁
----------	---------------------	----------------

Rim sherd; everted direct rim. Rd: 24.00 cm 1/16; Wd: 1.50 cm; H₁: 4.50 + x cm; throwing lines inside; smoothed on the wheel; eroded.

No. 14: tray, fragment, Nile C₂, Wd: 2.30 cm: 0.25 dm².

**Egyptian marls,
household ware**

No. 15: juglet, Inv. No. C-0628 [015]

Uncoated	Marl F	Ha ₂
----------	--------	-----------------

Handle fragment; Hd: 1.80 x 1.50 cm; 1; single strap; oval in section; eroded.

No. 16: jar (Fig. 1:2), Inv. No. C-0628 [003]Uncoated | Marl F | W₂

Rim sherd; inverted direct rim. Rd: 12.00 cm 3/8; Wd: 0.50 cm; H₁: 4.00 + x cm; throwing lines inside; smoothed on the wheel; eroded.

No. 17: amphora (Fig. 1:2), Inv. No. C-0628 [012]Uncoated | Marl F | W₂ + Ha₂

Shoulder and handle fragment; "torpedo" type; attached vertical loop handle. Md: 28.00 cm 1/8; Wd: 1.00 cm; H₁: 5.00 + x cm; Hd: 4.20 x 2.70 cm; 1; single strap; oval in section. Throwing lines inside; smoothed on the wheel; eroded. Another, Md: 28.00 cm 1/8; Hd: 4.00 x 2.80 cm.

Body sherds, Nile B₂ and C: 33.00 dm².

b) Imported pottery**Levantine household ware**

No. 18: amphora, Inv. No. C-0628, IV.TG 35 = IV.Phoen.01, body sherds: 0.10 dm².

II.- Finds**Scarab**

No. 19: scarab seal (Plate 1), Inv. No. F0622 (Drawing No. 0443; object sketch). Complete; faience; moulded. 1.30 x 0.90 x 0.70 cm; colour: 2.5Y 6/3 light yellowish brown. Description: carved on both sides; the back has a painted design; the base is decorated with a hieroglyphic inscription: *Imn-R^c (Mn - hpr - R^c)*; longitudinal perforation. SCA No. 4032. *Find No. 90.*

Weights

No. 20: net weight (Fig. 1:2), Inv. No. F0851A (Drawing No. 0930). Complete; lead; melted. 1.60 x 2.05 x 1.40 cm; U-shape. *Find No. 087.*

No. 21: net weight (Fig. 1:2), Inv. No. F0853A (Drawing No. 0930). Fragmentary; lead; melted. 1.70 x 2.10 x 1.80 cm. *Find No. 088.*

No. 22: scale weight (Fig. 1:3), Inv. No. F0938A (Drawing No. 0943). Complete; limestone. Weight: 103.00 gr. 3.80 x 3.80 x 4.00 cm. Cubic shape. *Find No. 082.*

Weapon

No. 23: slingstone (Fig. 1:3), Inv. No. F0942A (Drawing No. 0945). Complete; limestone. Weight: 174 grs. 4.60 x 4.80 cm. *Find No. 081.*

L0372**Finds****Object of unknown use**

No. 1: fragment of an object, Inv. No. F0949A. Pink granite. 5.40 x 5.80 x 4.20 cm; polished.

LEVEL II: Building A and Structure G

Both structures must be considered archaeologically contemporary, since careful observation failed to note any stratigraphic difference between them. Of course, a certain *décalage* cannot be ruled out. Note that whereas Building A was destroyed by a fire, there

is no indication of conflagration in Structure G, although it should have been constructed with light, organic materials.

Building A

1.- General description

This structure ([Plan II](#)) has been excavated only in part. It possessed at least two rooms (A-1 and A-2) and seems to have been rectangular in layout. Its longer axis runs WNW-ESE, the same as several other structures of Tell el-Ghaba, including some of the aforementioned foundation trenches and overlying Building B. This consistency suggests an enduring regulation of the space.

The first construction phase was the digging of the foundation trenches into sand **L0266**. Two of them (**L0101** and L0102) were double. In the southernmost trench **L0353** of Room A-2, a possible foundation deposit (**L0356**; Plate VII) was discovered. It included a pumice sharpening stone (Inv. No. F0870); two juglets (Inv. No. P1092A and P1110A); a jar (Inv. No. P1201A); sixteen doughnut-shaped objects of baked and unbaked clay (Inv. No. F0605A, F0607A, F0608A, F0611A, F0613A, F0617, F0618A, F0620A, F0621A, F0624A, F0626A, F0628A, F0631A, F0633A, F0635A, F0708A), which seem to be loom weights; slag, a fragment of a bronze object and a faience bead (Inv. No. F0702A). Room A-2 had an entrance at the S side, indicated by a door socket and the corresponding stopper, both in limestone. Burnt marks identified in the northernmost foundation trench of Room A-2 suggest that the walls consisted of upright reeds or rushes. Resting on this same ditch (L0211P) beside Room A-1 (where burning was not so intense), a Levantine Bichrome jar (Inv. No. P0387B) was found containing a stone plaque (Inv. No. F0235). It is, perhaps, another foundation deposit (**L0211**).

At least the eastern room -the one provided with a door socket- was roofed, as indicated by two limestone blocks, which are interpreted as post bases. Hearths were placed directly over the floor.

Building A was thoroughly burnt. Alternating oxidization and carbonisation affected the fill of the foundation trenches and the floor ([Plate VI](#)).

Locus	Square/s	Description	Interpretation, comments
L0319P = L0211P	BB/42	Ditch	Foundation trench of external (northern) wall.
L0101	BA/42	Ditch	Double foundation trench of inner wall, filled by L0050 and L0052 .
L0102	B/A42	Ditch	Double foundation trench of external (southern) wall, western branch. Filled by L0035 .
L0353	BB/41	Ditch	Foundation trench of external (southern) wall, eastern branch, filled by L0356 .
L0319 = L0211	BB/42 and BA/42-BA/43	Burnt fill of ditch	Burnt fill of north foundation trench of Building A. It was rich in clay (<i>muna</i>) and featured round marks c. 5 - 8 mm wide, interpreted as the burnt remains of the upright reeds or rushes forming the wall. An almost complete pot (Inv. No. P0387B) was found on its western branch

Locus	Square/s	Description	Interpretation, comments
L0319 = L0211	BB/42 and BA/42-BA/43	Burnt fill of ditch	(perhaps in a corner; but more excavation is needed). It was painted, featured a swastika and enclosed a stone plaque with a hieroglyphic inscription (Inv. No. F0035) carved on both faces. It may be a foundation deposit.
L0050 = L0052	BA/42	Line of oxidization / carbonisation	Fill of the double foundation trench L0101 of inner wall.
L0035	BA42	Clean yellow sand, fringed by very dark, carbonaceous sediment	Oxidized fill of south foundation trench, western branch. It fills double foundation trench L0102.
L0352	BB/41	Burnt fill of ditch	Oxidized fill of south foundation trench, eastern branch. It fills foundation trench L0353 . Contains foundation deposit (?) L0356 .
L0040 = L0043 = L0044	BA/42 BB/42	An oxidized and carbonised surface	Floor. No floor preparation was identified. Several locus numbers were assigned to different parts of this floor according to changes in coloration; but it was concluded that these differences resulted from different degrees of thermal alteration and lacked stratigraphic significance.
L0290 = L0346	BA/42-BB/42	Hearth	A thick feature. It was placed on L0345, an early floor of Building A, and seems to have been in use during the formation of floor L0040.
L0316	BB/42	Hearth	A thin feature. An arch of <i>muna</i> bordering its south side may have served to support cooking pots.
L0345	BA/42-BB/42	Floor	An early floor of Building A. It could be separated from L0040 only where overlaid by hearth L0290 = L0346.

2.- Archaeological material

L0035 (Fig. 2)

Finds

Raw material

No. 1: fragment of pumice (Fig. 2), Inv. No. F0136A (Drawing No. 0124, F28). 7.90-5.60 x 10.80 x 4.10-2.20 cm. Find No. 68.

L0040 = L0043 = L0044 (Fig. 3)

I.- Pottery

a) Egyptian pottery

Nile silt clay***Fine ware*****No. 1: bowl** (Fig. 3:1), Inv. No. P1109A (Drawing No. 0632)

RP	Nile B ₂	W ₂	---	ox.	2-3
----	---------------------	----------------	-----	-----	-----

Rim and shoulder fragment; incurved rim. Rd: 12.00 cm 1/16; Wd: 0.60 cm; H₁: 2.50 + x cm. Surface colour: 10R 4/8 red slip. Break: reddish brown core; brownish red oxidation zones. Technical details: convex sided walls; a groove below the rim. Surface treatment: horizontally burnished, high lustre. Smoked on the rim.

Household ware**No. 2: bowl?** (Fig. 3:1), Inv. No. C-0427 [037]

Uncoated	Nile B ₂	W ₂
----------	---------------------	----------------

Rim sherd; inverted articulated exterior rim, trimmed lip. Rd: 20.00 cm 3/32; Wd: 1.00 cm; H₁: 2.40 + x cm. Throwing lines inside; smoothed on the wheel.

No. 3: bowl (Fig. 3:1), Inv. No. C-0427 [080]

RS	Nile B ₂	W ₂
----	---------------------	----------------

Rim sherd; inverted articulated symmetrical rim, round lip. Rd: 12.00 cm 1/8; Wd: 0.70 cm; H₁: 3.70 + x cm. Throwing lines inside; red slipped surface; smoothed on the wheel.

No. 4: bowl (Fig. 3:1), Inv. No. C-0644 [013]

Uncoated	Nile B ₂	W ₂
----------	---------------------	----------------

Rim sherd; incurved walls; everted articulated interior rim, round lip. Rd: 18.00 cm 1/16; Wd: 0.45 cm; H₁: 2.60 + x cm. Throwing lines inside; smoothed on the wheel; eroded.

No. 5: bowl (Fig. 3:1), Inv. No. C-0060 [003]

Uncoated	Nile B ₂	W ₂
----------	---------------------	----------------

Rim sherd; incurved walls; inverted articulated interior rim. Rd: 22.00 cm 1/16; Wd: 0.70 cm; H₁: 4.75 + x cm. Throwing lines inside; smoothed on the wheel; smoked inside.

No. 6: bowl (Fig. 3:1), Inv. No. C-0059 [010]

Uncoated	Nile B ₂	W ₂
----------	---------------------	----------------

Rim sherd; incurved walls; inverted direct rim. Rd: 20.00 cm 1/32; Wd: 0.50 cm; H₁: 1.30 + x cm. Throwing lines inside; smoothed on the wheel.

No. 7: bowl (Fig. 3:1), Inv. No. C-0644 [021]

Uncoated	Nile B ₂	W ₂
----------	---------------------	----------------

Rim sherd; incurved walls; inverted direct rim, round lip. Rd: 22.00 cm 1/16; Wd: 0.50 cm; H₁: 3.40 + x cm. Throwing lines inside; smoothed on the wheel; eroded.

No. 8: bowl (Fig. 3:1), Inv. No. C-0644 [014]

Uncoated	Nile B ₂	W ₂
----------	---------------------	----------------

Rim sherd; incurved walls; inverted articulated symmetrical rim, trimmed lip. Rd: 22.00 cm 3/32; Wd: 0.70 cm; H₁: 4.60 + x cm. Throwing lines inside; smoothed on the wheel; eroded.

No. 9: bowl (Fig. 3:1), Inv. No. C-0427 [044]

Uncoated	Nile B ₂	W ₂
----------	---------------------	----------------

Rim sherd; vertical articulated exterior rim, rounded lip. Rd: 26.00 cm 1/8; Wd: 0.60 cm; H₁: 5.00 + x cm. Throwing lines inside; smoothed on the wheel.

No. 10: bowl (Fig. 3:1), Inv. No. C-0427 [031]

Uncoated	Nile B ₂	W ₂
----------	---------------------	----------------

Rim sherd; everted articulated exterior rim. Rd: 32.00 cm 3/32; Wd: 1.10 cm; H₁: 6.70 + x cm. Smoked rim, eroded. Others, Rd: 17.00 cm 1/8, Rd: 18.00 cm 1/16, Rd: 20.00 cm 1/4, Rd: 22.00 cm 1/8, Rd: 24.00 cm 1/4, Rd: 26.00 cm 1/8, Rd: 26.00 cm 3/32, Rd: 30.00 cm 1/16. Nile E₁, Rd: 22.00 cm 3/32. Nile E₂, Rd: 24.00 cm 1/16.

No. 11: bowl (Fig. 3:1), Inv. No. C-0427 [032]

Uncoated	Nile B ₂	W ₂
----------	---------------------	----------------

Rim sherd; everted articulated exterior rim. Rd: 24.00 cm 3/32; Wd: 0.70 cm; H₁: 1.30 + x cm; smoothed on the wheel; eroded inside.

No. 12: bowl (Fig. 3:1), Inv. No. C-0427 [030]

Uncoated	Nile B ₂	W ₂
----------	---------------------	----------------

Rim sherd; everted direct rim. Rd: 30.00 cm 3/32; Wd: 1.00 cm; H₁: 5.00 + x cm. Throwing lines inside; smoothed on the wheel; eroded. Others, Rd: 18.00 cm 1/8, Rd: 20.00 cm 1/8, Rd: 24.00 cm 3/32, Rd: 28.00 cm 3/32. Nile C₁, Rd: 24.00 cm 3/32, Rd: 30.00 cm 1/16. Nile C₂, Rd: 36.00 cm 1/16. Nile E₁, Rd: 24.00 cm 3/32.

No. 13: bowl (Fig. 3:2), Inv. No. C-0427 [036]

Uncoated	Nile B ₂	W ₂
----------	---------------------	----------------

Rim sherd; everted direct rim, trimmed lip. Rd: 16.00 cm 3/32; Wd: 0.80 cm; H₁: 1.70 + x cm. Throwing lines inside; smoothed on the wheel; eroded rim.

No. 14: bowl (Fig. 3:2), Inv. No. C-0427 [040]

Uncoated	Nile B ₂	W ₂
----------	---------------------	----------------

Rim sherd; everted articulated exterior rim, trimmed lip. Rd: 18.00 cm 3/32; Wd: 0.60 cm; H₁: 2.50 + x cm. Throwing lines inside; smoothed on the wheel.

No. 15: bowl (Fig. 3:2), Inv. No. C-0427 [043]

Uncoated	Nile B ₂	W ₂
----------	---------------------	----------------

Rim sherd; everted articulated symmetrical rim, trimmed lip. Rd: 18.00 cm 3/32; Wd: 0.70 cm; H₁: 3.80 + x cm. Throwing lines inside; smoothed on the wheel.

No. 16: bowl (Fig. 3:2), Inv. No. C-0427 [041]

Uncoated	Nile B ₂	W ₂
----------	---------------------	----------------

Rim sherd; inverted articulated symmetrical rim, round lip. Rd: 16.00 cm 1/16; Wd: 0.50 cm; H₁: 2.50 + x cm. Throwing lines inside; smoothed on the wheel.

No. 17: bowl (Fig. 3:2), Inv. No. C-0060 [001]

Uncoated	Nile B ₂	W ₂
----------	---------------------	----------------

Rim sherd; carinated walls; everted direct rim. Rd: 26.00 cm 1/8; Wd: 0.90 cm; H₁: 4.50 + x cm. Throwing lines inside; smoothed on the wheel.

No. 18: bowl (Fig. 3:2), Inv. No. C-0644 [023]

Uncoated	Nile B ₂	W ₂
----------	---------------------	----------------

Rim sherd; slightly everted direct rim, round lip. Rd: 20.00 cm 3/32; Wd: 0.90 cm; H₁: 6.40 + x cm. Throwing lines inside; smoothed on the wheel; eroded; smoke inside.

No. 19: bowl?, Inv. No. C-0059 [005]

Uncoated	Nile B ₂	W ₁	W
----------	---------------------	----------------	---

Base fragment; rounded base, flattened. Wd: 0.56 cm; H_1 : 0.80 + x cm. Throwing lines inside; smoothed on the wheel.

No. 20: goblet (Fig. 3:2), Inv. No. P7006A (Drawing No. 0901)

RS	Nile B ₂	W ₂	W	ox.	2
----	---------------------	----------------	---	-----	---

Foot fragment, 1/2. Fd: 5.00 cm; Wd: 0.30 cm; H_1 : 4.20 + x cm; H_4 : 3.90 cm. Surface colour: 10R 5/6 red slip. Break: 2.5YR 5/6 red. Technical details: throwing lines outside and inside. Surface treatment: smoothed on the wheel.

No. 21: cup (Fig. 3:2), Inv. No. C-0427 [017]

Uncoated	Nile B ₂	W ₂
----------	---------------------	----------------

Rim sherd; incurved walls; inverted direct rim. Rd: 10.00 cm 3/32; Wd: 0.45 cm; H_1 : 3.00 + x cm. Throwing lines inside; smoothed on the wheel.

No. 22: cup (Fig. 3:2), Inv. No. C-0427 [056]

Uncoated	Nile B ₂	W ₂
----------	---------------------	----------------

Rim sherd; everted direct rim. Rd: 10.00 cm 3/32; Wd: 0.40 cm; H_1 : 3.20 + x cm. Throwing lines inside; smoothed on the wheel; eroded rim. Another, Rd: 10.00 cm 3/32.

No. 23: juglet (Fig. 3:2), Inv. No. C-0644 [049]

Uncoated	Nile B ₂	W ₂ + Ha ₂
----------	---------------------	----------------------------------

Rim and handle fragment; vertical direct rim. Rd: 8.00 cm 3/32; Wd: 0.40 cm; H_1 : 1.90 + x cm; Hd: 1.00 x 1.00 cm. Throwing lines inside; smoothed.

No. 24: pilgrim flask (Fig. 3:2), Inv. No. P1198A (Drawing No. 0912)

Uncoated	Nile B ₂	W ₂ + Ha ₂	---	ox.	2
----------	---------------------	----------------------------------	-----	-----	---

Neck fragment and handles; oval in section 2; single strap. Nd: 1.15 cm; Wd: 0.45 cm; H_1 : 2.80 + x cm; H_3 : 2.35 + x cm; Hd: 0.80 x 0.50 cm. Surface colour: 5YR 6/4 light reddish brown. Break: 5YR 6/4 light reddish brown. Technical details: handles applied from neck to shoulder; neck opened with a tool. Surface treatment: smoothed.

No. 25: jar (Fig. 3:2), Inv. No. C-0053 [006]

Uncoated	Nile B ₂	W ₂
----------	---------------------	----------------

Rim sherd; slightly inverted articulated rim. Rd: 10.00 cm 5/32; Wd: 0.45 cm; H_1 : 3.30 + x cm. Throwing lines inside; smoothed on the wheel.

No. 26: jar (Fig. 3:2), Inv. No. C-0427 [081]

RS	Nile E ₁	W ₂
----	---------------------	----------------

Rim sherd; slightly everted direct rim. Rd: 5.00 cm 3/16; Wd: 0.34 cm; H_1 : 2.90 + x cm. Throwing lines inside; red slipped surface; smoothed on the wheel.

No. 27: jar (Fig. 3:2), Inv. No. P0880A (before P0061A. Drawing No. 0228)

Uncoated	Nile B ₂	W ₂	---	ox.	2-3
----------	---------------------	----------------	-----	-----	-----

Nearly complete shape, fragmentary; globular shape; everted direct rim. Rd: 10.80-11.00 cm; Nd: 9.00 cm; Md: 20.00 cm; Wd: 0.90 cm; H_1 : 24.00 + x cm; H_2 : 10.60 cm; H_3 : 4.50 cm; VI: ca. 77. Surface colour: 2.5YR 6/4 light reddish brown. Break: thick core, 5YR 5/1 grey; thin oxidation zones, 2.5YR 6/4 light reddish brown. Technical details: "s" ware; deformed. Surface treatment: smoothed on the wheel. Smoked.

No. 28: jar, Inv. No. C-0054 [001]

Uncoated	Nile B ₂	W ₂
----------	---------------------	----------------

Rim sherd; everted direct rim. Rd: 10.00 cm $\frac{1}{4}$; Wd: 0.47 cm; H_1 : 5.00 + x cm. Throwing lines inside; smoothed on the wheel; overfired. Others, Rd: 10.00 cm $\frac{3}{8}$, Rd: 12.00 cm $\frac{3}{8}$. Nile C₁, Rd: 16.00 cm $\frac{1}{16}$.

No. 29: jar (Fig. 3:3), Inv. No. C-0059 [001]

Uncoated	Nile B ₂	W ₂
----------	---------------------	----------------

Rim sherd; everted articulated exterior and interior rim, round lip. Rd: 11.00 cm $\frac{1}{4}$; Wd: 0.55 cm; H_1 : 3.70 + x cm; overfired.

No. 30: jar (Fig. 3:3), Inv. No. C-0059 [002]

Uncoated	Nile B ₂ v.f.	W ₂
----------	--------------------------	----------------

Rim sherd; everted articulated exterior rim, round lip. Rd: 16.00 cm $\frac{1}{8}$; Wd: 0.50 cm; H_1 : 4.70 + x cm. Throwing lines inside; smoothed on the wheel. Another, Rd: 20.00 cm $\frac{1}{16}$.

No. 31: jar (Fig. 3:3), Inv. No. C-0427 [055]

Uncoated	Nile B ₂	W ₂
----------	---------------------	----------------

Rim sherd; everted articulated interior rim. Rd: 10.00 cm $\frac{1}{8}$; Wd: 0.40 cm; H_1 : 3.20 + x cm. Throwing lines inside; smoothed on the wheel; eroded.

No. 32: jar (Fig. 3:3), Inv. No. C-0427 [001]

Uncoated	Nile B ₂	W ₂
----------	---------------------	----------------

Rim sherd; slightly inverted direct rim. Rd: 10.00 cm $\frac{3}{16}$; Wd: 0.65 cm; H_1 : 4.10 + x cm. Throwing lines inside; smoothed on the wheel; eroded. Others, Rd: 9.00 cm $\frac{5}{32}$.

No. 33: jar (Fig. 3:3), Inv. No. C-0427 [004]

Uncoated	Nile E ₁	W ₂
----------	---------------------	----------------

Rim sherd; slightly inverted articulated interior rim, round lip. Rd: 10.00 cm $\frac{1}{8}$; Wd: 0.60 cm; H_1 : 4.30 + x cm. Throwing lines inside; smoothed on the wheel; eroded. Others, Rd: 10.00 cm $\frac{1}{4}$, Rd: 16.00 cm $\frac{1}{8}$.

No. 34: jar (Fig. 3:3), Inv. No. C-0427 [011]

Uncoated	Nile C ₁	W ₂
----------	---------------------	----------------

Rim sherd; vertical direct rim. Rd: 8.00 cm $\frac{3}{32}$; Wd: 0.70 cm; H_1 : 2.80 + x cm. Throwing lines inside; smoothed on the wheel. Others, Rd: 8.00 cm $\frac{3}{32}$, Rd: 9.00 cm $\frac{3}{16}$, Rd: 12.00 cm $\frac{3}{8}$, Rd: 16.00 cm $\frac{3}{32}$. Nile C₁, Rd: 8.00 cm, $\frac{3}{32}$.

No. 35: jar (Fig. 3:3), Inv. No. C-0427 [008]

Uncoated	Nile B ₂	W ₂
----------	---------------------	----------------

Rim sherd; vertical modelled rim inside. Rd: 8.00 cm $\frac{1}{8}$; Wd: 0.70 cm; H_1 : 3.10 + x cm. Throwing lines inside; smoothed on the wheel.

No. 36: jar, Inv. No. C-0644 [053]

Uncoated	Nile B ₂	W ₂	W
----------	---------------------	----------------	---

Base fragment; round base. Wd: 0.60 cm; H_1 : 1.60 + x cm. Throwing lines inside; smoothed on the wheel. Others, 3 bases.

No. 37: storage jar, Inv. No. C-0427 [048]

Uncoated	Nile B ₂	W ₂	W
----------	---------------------	----------------	---

Base fragment; round base. Wd: 0.70 cm; H_1 : 3.00 + x cm. Finger marks inside. Others, 5 bases. Nile C₁, 1 base. Nile E₂, 1 base.

No. 38: storage jar (Fig. 3:3), Inv. No. C-0427 [062]

Uncoated	Nile B ₂	W ₂
----------	---------------------	----------------

Rim sherd; inverted direct rim, folded lip. Rd: 30.00 cm 1/8; Wd: 0.85 cm; H₁: 5.00 + x cm; eroded.

No. 39: storage jar (Fig. 3:3), Inv. No. C-0644 [015]

Uncoated	Nile B ₂	W ₂
----------	---------------------	----------------

Rim sherd; inverted articulated exterior rim, round lip. Rd: 20.00 3/32; Wd: 0.60 cm; H₁: 4.10 + x cm. Throwing lines inside; smoothed on the wheel; eroded. Others, Rd: 20.00 cm 1/8, Rd: 26.00 cm 1/16.

No. 40: storage jar (Fig. 3:3), Inv. No. C-0427 [028]

Uncoated	Nile B ₂	W ₂
----------	---------------------	----------------

Rim sherd; inverted direct rim, trimmed lip. Rd: 26.00 cm 1/8; Wd: 1.20 cm; H₁: 3.50 + x cm. Throwing lines inside; smoothed on the wheel.

No. 41: storage jar (Fig. 3:3), Inv. No. C-0427 [024]

Uncoated	Nile C ₁	W ₂
----------	---------------------	----------------

Rim sherd; inverted articulated exterior rim, folded lip. Rd: 32.00 cm 1/8; Wd: 0.90 cm; H₁: 3.60 + x cm. Throwing lines inside; smoothed on the wheel; eroded on the rim, outside.

No. 42: storage jar (Fig. 3:3), Inv. No. P0072A (Drawing No. 0193)

Uncoated	Nile B ₂	W ₂	---	ox.	2
----------	---------------------	----------------	-----	-----	---

Rim sherd; interior and exterior lip. Rd: 26.00 cm 1/4; Wd: 0.60 cm; H₁: 6.00 + x cm. Surface colour: 2.5YR 8/2 pale yellow self slip for overfired. Break: 2.5YR 5/1 dark reddish grey core; 2.5YR 5/8 red oxidation zones. Surface treatment: smoothed on the wheel.

No. 43: storage jar (Fig. 3:4), Inv. No. C-0427 [022]

Uncoated	Nile B ₂	W ₂
----------	---------------------	----------------

Rim sherd; vertical articulated symmetrical rim. Rd: 36.00 cm 1/16; Wd: 0.90 cm; H₁: 5.20 + x cm. Throwing lines inside; smoothed on the wheel; eroded inside.

No. 44: storage jar (Fig. 3:4), Inv. No. C-0427 [027]

Uncoated	Nile B ₂	W ₂
----------	---------------------	----------------

Rim sherd; vertical articulated symmetrical rim, trimmed lip. Rd: 20.00 cm 1/8; Wd: 0.55 cm; H₁: 3.50 + x cm. Throwing lines inside; smoothed on the wheel. Another, Rd: 30.00 cm 1/16.

No. 45: storage jar (Fig. 3:4), Inv. No. C-0427 [021]

Uncoated	Nile B ₂	W ₂
----------	---------------------	----------------

Rim sherd; vertical direct rim, folded lip. Rd: 32.00 cm 1/16; Wd: 1.00 cm; H₁: 4.80 + x cm. Throwing lines inside; smoothed on the wheel.

No. 46: storage jar (Fig. 3:4), Inv. No. C-0427 [026]

Uncoated	Nile B ₂	W ₂
----------	---------------------	----------------

Rim sherd; vertical articulated exterior rim, round lip. Rd: 24.00 cm 1/16; Wd: 0.65 cm; H₁: 3.60 + x cm. Throwing lines inside; smoothed on the wheel; eroded outside on the rim.

No. 47: storage jar (Fig. 3:4), Inv. No. C-0427 [025]

Uncoated	Nile C ₁	W ₂
----------	---------------------	----------------

Rim sherd; vertical articulated exterior rim. Rd: 24.00 cm 3/32; Wd: 1.15 cm; H₁: 2.70 + x cm. Throwing lines inside; smoothed on the wheel; eroded outside of the rim. Another, Rd: 30.00 cm 3/32.

No. 48: storage jar (Fig. 3:4), Inv. No. C-0427 [020]

Uncoated	Nile B ₂	W ₂
----------	---------------------	----------------

Rim sherd; everted articulated symmetrical rim. Rd: 36.00 cm 1/8; H₁: 3.70 + x cm. Throwing lines inside; smoothed on the wheel; eroded rim. Others, Rd: 18.00 cm 3/32, Rd: 20.00 cm 3/32, Rd: 26.00 cm 1/16.

No. 49: storage jar, Inv. No. C-0054 [006]

Uncoated	Nile B ₂	W ₂	W
----------	---------------------	----------------	---

Base fragment; nipple base?. Wd: 0.90 cm; H₁: 4.00 + x cm. Throwing lines inside; smoothed on the wheel.

No. 50: amphora, handle fragment, Nile B₂, Hd: 3.20 x 2.00 cm. Others, Hd: 2.90 x 1.87 cm; Hd: 3.30 x 2.10 cm; Hd: 3.00 x 1.30 cm.

Pottery with special functions

No. 51: bakery tray (Fig. 3:4), Inv. No. C-0054 [003]

Uncoated	Nile C ₁	W ₁
----------	---------------------	----------------

Rim sherd; everted direct rim. Rd: 18.00cm 3/32; Wd: 1.62 cm; H₁: 3.80 + x cm.

No. 52: bakery tray, base fragment, Nile C₂, 3 bases, eroded.

Egyptian marls

Household ware

No. 53: jug, (Fig. 3:4), Inv. No. P0861A (Drawing No. 0398)

Uncoated	Marl F v.s.	Ha ₂	---	ox.	3
----------	-------------	-----------------	-----	-----	---

Handle fragment; vertical handle; 1; double strap. Wd: 1.80 cm; H₁: 9.60 + x cm; Hd: 0.96 x 1.80 cm. Surface colour: 10YR 8/3 very pale brown self-slip. Break: 10YR 7/2 light grey. Technical details: irregular section. Surface treatment: smoothed.

No. 54: jar (Fig. 3:4), Inv. No. P0131A (Drawing No. 0712)

Uncoated	Marl F + limestone	W ₂	---	ox.	3
----------	--------------------	----------------	-----	-----	---

Body fragment, globular shape. Md: ca.18.20 cm; Wd: 0.50 cm; H₁: 5.90 + x cm. Surface colour: 5YR 6/6 reddish yellow; 5YR 7/4 pink self-slip. Break: 5YR 6/6 reddish yellow-5/6 yellowish red. Surface treatment: smoothed on the wheel.

No. 55: jar (Fig. 3:4), Inv. No. C-0053 [003]

Uncoated	Marl F	W ₂
----------	--------	----------------

Rim sherd; vertical direct rim. Rd: 9.00 cm 1/4; Wd: 0.40-0.67 cm; H₁: 3.10 + x cm. Throwing lines inside and outside; smoothed on the wheel.

No. 56: amphora, Inv. No. P7034A (Drawing No. 0900)

Uncoated	Marl F	Ha ₂	---	ox.	3
----------	--------	-----------------	-----	-----	---

Handle fragment; oval in section; single strap. Hd: 2.75 x 2.35 cm. Surface colour: 7.5YR 6/3 light brown self-slip. Break: 7.5YR 6/4 light brown. Surface treatment: smoothed.

Body sherds, Nile B₂: 30.00 dm², Nile C₁₋₂: 9.50 dm², Nile E: 1.20 dm², Marl A₄, Marl F

and Marl F v.s.

b) North Sinai/South Palestine pottery

Household ware

No. 57: amphora, Inv. No. C-0427, similar to II.TG 08, body sherds: 0.10 dm².

No. 58: amphora, Inv. No. C-0427, II.TG 09, body sherds: 0.30 dm².

No. 59: footed bowl (Fig. 3:4), Inv. No. P1230A (Drawing No. 0623)

Coated	II.TG 10	W ₂	W	ox.	3
--------	----------	----------------	---	-----	---

Foot fragment. Fd: 3.80 + x cm; Wd: 0.65 cm; H₄: 3.60 + x cm. Surface treatment: 7.5YR 8/4 pink slip. Break: 5YR 6/4 light reddish brown. Surface treatment: smoothed on the wheel.

No. 60: amphora, Inv. No. C-0427, II.TG 10, body sherds: 0.30 dm².

No. 61: amphora, Inv. No. C-0427, II?.TG 59, body sherds: 0.20 dm².

c) Levantine pottery

Fine ware

No. 62: juglet (Fig. 3:5), Inv. No. P1270A (Drawing No. 0705)

WSMO	IV.TG 36	W ₂ + Ha ₂	ox.	3
------	----------	----------------------------------	-----	---

Rim sherd, pinched rim. Rd: 6.00 cm; Wd: 0.30 cm; H₁: 2.10 + x cm. Surface colour: 2.5Y 8/1 white slip. Decoration: a painted band on the rim, 2.5Y 4/1 dark grey.

No. 63: pilgrim flask (Fig. 3:5), Inv. No. P1032A (Drawing No. 0926)

WP	IV.TG 37 = IV.Phoen?03	W ₂ + Ha ₂	---	ox.	3
----	------------------------	----------------------------------	-----	-----	---

Handle and body; single strap. Md: ca. 10.00 cm; Wd: 0.45 cm; H₁: 3.50 + x cm; Hd: 0.90 x 1.00 cm. Surface colour: 5YR 7/4 pink slip. Break: 2.5YR 5/4 reddish brown. Technical details: made in two halves, which are then joined. Surface treatment: polished, medium lustre.

No. 64: jar (Fig. 3:5), Inv. No. P1232A (Drawing No. 0935)

P	IV.TG 51 (=TD IV.19)	W ₂	---	ox.	3
---	----------------------	----------------	-----	-----	---

Shoulder sherd; collared neck. Md: 12.00 + x cm; Wd: 0.75 cm; H₁: 3.10 + x cm; Hd: 1.00 x 0.80 cm. Surface colour: 5YR 5/6 yellowish red. Break: 5YR 6/6 reddish yellow. Technical details: throwing lines inside. Surface treatment: polished, low lustre.

Household ware

No. 65: barrel-shaped jar (Fig. 3:5), Inv. No. P1274A (Drawing No. 0706)

Uncoated	≅ TD IV.08	W ₂	closed with the fingers	ox.	3
----------	------------	----------------	-------------------------	-----	---

Body fragment. Bd: 3.50 cm; Wd: 0.80 cm; H₁: 1.50 + x cm. Surface colour: 5YR 6/6 reddish yellow. Break: 5YR 7/6 reddish yellow. Technical details: throwing lines; base closed with the fingers, flattened and then smoothed. Surface treatment: smoothed on the wheel.

No. 66: amphora, Inv. No. C-0427, IV.TG 01, body sherds: 0.10 dm².

No. 67: amphora, Inv. No. C-0427, similar to IV.TG 01, body sherds: 0.10 dm².

No. 68: amphora, Inv. No. C-0644, IV.TG 07, body sherds: 0.30 dm².

No. 69: amphora, Inv. No. C-0427, IV.TG 17, body sherds: 0.40 dm².

No. 70: amphora, Inv. No. C-0050, IV.TG 18, body sherds: 0.20 dm².

No. 71: amphora, Inv. No. C-0427, IV.TG 21, body sherds: 0.10 dm².

No. 72: amphora, Inv. No. C-9016 [001]

Uncoated	IV.TG 23	Ha ₂
----------	----------	-----------------

Handle fragment; single strap; eroded.

No. 73: amphora, Inv. No. C-0644, IV.TG 23, body sherds: 0.50 dm².

No. 74: amphora, Inv. No. C-0427, IV.TG 23 c., body sherds: 0.10 dm².

No. 75: amphora, Inv. No. C-0644, IV.TG 24, body sherds: 0.60 dm².

No. 76: amphora, Inv. No. C-0427 IV.TG 29, body sherds: 0.10 dm².

No. 77: amphora, Inv. No. C-0427, IV.TG 36, body sherds: 0.10 dm².

No. 78: amphora, Inv. No. P1273A (Drawing No. 0620)

Uncoated	IV.TG 51 (=TD IV.19)	Ha ₂	---	ox.	3
----------	----------------------	-----------------	-----	-----	---

Handle fragment; vertical handle; single strap. Wd: 1.00 cm; Hd: 3.00 x 2.40 cm. Surface colour: 10YR 8/3 very pale brown. Break: 10YR 5/1 grey core; 7.5YR 6/6 reddish yellow oxidation zones. Surface treatment: smoothed.

No. 79: amphora (Fig. 3:5), Inv. No. P1231A (Drawing No. 0705)

Coated	IV.TG 51 (= TD IV.19)	Ha ₂	---	ox.	3
--------	-----------------------	-----------------	-----	-----	---

Handle fragment; single strap. Hd: 3.10 x 1.90 cm. Surface colour: 5YR 7/4 pink slip. Break: 10YR 3/1 very dark grey core; 5YR 5/4 reddish brown oxidation zones. Surface treatment: smoothed.

No. 80: amphora, Inv. No. C-0644, IV.TG 51 (= TD IV.19), body sherds: 0.70 dm².

No. 81: amphora, Inv. No. C-0427, IV.TG 53 (= TD IV.09), body sherds: 0.10 dm².

No. 82: amphora, Inv. No. C-0427, = TD IV.02, body sherds: 0.30 dm².

No. 83: amphora, Inv. No. C-0644 [054]

Uncoated	= TD IV.08	Ha ₂
----------	------------	-----------------

Handle fragment; single strap; eroded.

No. 84: amphora, Inv. No. C-0427, = TD IV.08, body sherds: 0.70 dm².

No. 85: amphora, Inv. No. C-0644, = TD IV.08 c., body sherds.

Levantine pottery with special functions

No. 86: oil lamp (Fig. 3:5), Inv. No. P0761A (Drawing No. 0304)

Uncoated	IV.TG 36	W ₂	W	ox.	2-3
----------	----------	----------------	---	-----	-----

Complete, fragmentary; mended; flat base; everted articulated exterior rim. Rd: ca. 13.50 cm; Wd: 0.70 cm; Bd: 5.48 cm; L: 13.30 cm; W: 12.00 + x cm; H₁: 5.10 cm. VI: 261. Surface colour: 5YR 6/6 reddish yellow. Break: 5YR 6/6 reddish yellow. Technical details: modelled rim. Surface treatment: smoothed. Smoked inside; oil spot remains.

Phoenician pottery

Fine ware

No. 87: juglet (Fig. 3:5), Inv. No. P0084A (Drawing No. 0051. F12)

WP	IV.TG 35 = IV.Phoen.01	W ₂	---	ox.	3
----	------------------------	----------------	-----	-----	---

Rim and neck sherd; everted rolled rim. Rd: 2.30 cm; Nd: 1.40 cm; Wd: 0.20 cm; H₃: 1.40 + x cm. Surface colour: 5YR 7/4 pink slip. Break: 5YR 7/4 pink. Technical details: everted rolled rim forming an outer lip, 4 mm wide. Surface treatment: polished, low lustre.

Phoenician household ware

No. 88: amphora, Inv. No. C-0644 [054]

Uncoated	IV.TG 37 = IV.Phoen?03	Ha ₂
----------	------------------------	-----------------

Handle fragment; single strap. Hd: 3.30 x 2.10 cm; smoothed.

No. 89: amphora, Inv. No. C-0644, IV. TG 37= IV. Phoen?03, body sherds: 0.20 dm².

Cypriote pottery

Fine ware

Black-on-Red II (IV) ware

No. 90: juglet (or barrel-shaped jar?) (Fig. 3:5), Inv. No. P0054A (Drawing No. 0085)

RPMO	VI.TG 04	W ₂	---	ox.	3
------	----------	----------------	-----	-----	---

Body sherd. Md: 6.00 + x cm; Wd: 0.22 cm; H₁: 2.05 + x cm. Surface colour: 2.5YR 5/6 red slip. Break: 5YR 6/6 reddish yellow. Technical details: throwing lines on the interior. Decoration: vertically painted lines, 1 mm wide, 2.5YR 3/1 reddish brown. Surface treatment: polished, low lustre.

Cypriote household ware

No. 91: jug? (Fig. 3:6), Inv. No. P0073A (Drawing No. 0211)

WS	VI?	W ₂ + Ha ₂	---	ox.	3
----	-----	----------------------------------	-----	-----	---

Neck and handle fragment, double strap. Nd: 4.00 cm; Wd: 0.40 cm; H₁: 2.27 + x cm; H₃: 4.30 cm; Hd: 2.50 x 1.50 cm. Surface colour: 7.5YR 7/4 pink slip. Break: 7.5YR 7/4 pink. Surface treatment: smoothed.

No. 92: amphora, Inv. No. C-0427, VI.TG 04, body sherds: 0.10 dm².

No. 93: amphora, Inv. No. C-0427, VI.TG 40, body sherds: 0.10 dm².

No. 94: amphora (Fig. 3:6), Inv. No. P1272A (Drawing No. 0927)

Coated	VI.TG 40	W ₂	W	ox.	3
--------	----------	----------------	---	-----	---

Base fragment; rounded base. Md: 12.00 + x cm; Wd: 0.65 cm; H₁: 6.60 + x cm. Surface colour: 10YR 7/3 very pale brown slip. Break: 7.5YR 5/1 grey core; 7.5YR 7/6 reddish yellow oxidation zones. Technical details: throwing lines inside and outside. Surface treatment: smoothed.

No. 95: amphora, Inv. No. C-0644, VI.TG 43, body sherds: 0.10 dm².

No. 96: amphora, Inv. No. C-0644, VI.TG 44, body sherds: 0.10 dm².

No. 97: amphora, Inv. No. C-0427, VI.TG 49, body sherds: 0.20 dm².

Aegean pottery

Fine ware

Black-on-Red II (IV) ware

No. 98: juglet (Fig. 3:6), Inv. No. P0057A (Drawing No. 0048. F12)

RPMO	VII.TG 39	W ₂	W	ox.	3
------	-----------	----------------	---	-----	---

Body sherd and part of the handle, horizontal handle. Md: 8.50 + x cm; Wd: 0.35 cm; H₁: 4.30 + x cm; Hd: 0.70 x 0.55 cm. Surface treatment: 2.5YR 6/8 red slip. Break: 2.5YR 6/6 red. Technical details: very fine throwing lines on the interior. Decoration: horizontally and vertically painted lines, 1-1.5 mm wide, 5YR 2.5/1 black. Surface treatment: polished; medium lustre. *Find No. 012.*

No. 98bis: juglet, Inv. No. P0056A (Drawing No. 0004)

RPMO	VII.TG 45	W ₂	W	ox.	3
------	-----------	----------------	---	-----	---

Body and base fragment; flat base. Md: 4.20 cm; Bd: 3.00 cm 3/16; Wd: 0.25 cm; H₁: 3.10 + x cm; H₂: 1.50 cm. Surface treatment: 2.5YR 5/6 red slip. Break: 5YR 6/6 reddish yellow. Technical details: very fine throwing lines on the interior. Decoration: horizontally painted lines, 1 mm wide, 2.5YR 3/1 reddish brown. Surface treatment: polished; medium

lustre. *Find No. 001.*

II.- Finds

Religion

No. 99: Sekhmet figurine (Plate 2), Inv. No. F0500 (Drawing No. 0275). Fragmentary; mended; faience; moulded. 0.70 x 3.60 x 1.60 cm; colour: 7.5YR 7/2 and 7.5YR 6/2 pinkish grey. Description: the goddess is seated on a throne and wears a crown; it has perforations depicting the eyes and the nose, and a lioness muzzle; the arms are missing, except part of the left one; a perforation of 1 mm behind the neck and a dorsal pillar. Function: amulet. SCA No. 2033. *Find No. 042.*

No. 100: heart amulet?, Inv. No. F0560A. Fragmentary; faience; moulded. 0.70 x 1.00 x 0.50 cm; colour: 10YR 7/2 (light grey). Description: lower part of a heart.

Personal objects

No. 101: pendant (Fig. 3:6 - Plate 2bis), Inv. No. F0025A (Drawing No. 0179). Complete; faience; moulded. 0.90 x 0.60 x 0.20 cm; colour: 5YR 8/1 white. Oval shape (front view); flat shape (side view); perforation: 1 mm. *Find No. 044.*

No. 102: bead (Fig. 3:6), Inv. No. F0438A (Drawing No. 0641). Complete; shell. 1.00 x 0.80 cm. *Find No. 036.*

No. 103: bead, Inv. No. F0512A (Drawing No. 0275). Fragmentary; faience. 0.10 (diameter) x 0.80 cm; colour: blue and 5 YR 5/2 reddish grey; cylindrical shape. *Find No. 043.*

No. 104: bead, Inv. No. F0516A. Complete; faience; moulded. 0.30 x 0.20 cm; colour: 2.5Y 8/2 (pale yellow); cylindrical shape; destroyed. *Find No. 039.*

No. 105: bead, Inv. No. F0517A (Drawing No. 0622). Complete; mended; faience; moulded. 0.40 x 0.30-0.20 cm; colour: 10YR 7/2 (light grey); cylindrical shape.

No. 106: bead, Inv. No. F0520A (Drawing No. 0622). Complete; faience; moulded. 0.20 (diameter) x 0.10 cm; colour: blue; cylindrical shape.

No. 107: bead, Inv. No. F0521A. Partial destroyed; faience. *Find No. 002.*

No. 108: bead (Fig. 3:6), Inv. No. F0548A (Drawing No. 0641). Complete; mended; faience; moulded. 0.70 x 0.30 cm; colour: 10YR 7/2 (light grey); cylindrical shape. *Find No. 001.*

No. 109: bead, Inv. No. F0549A (Drawing No. 0641). Complete; faience; moulded. 0.50 x 0.20 cm; colour: 10YR 7/2 (light grey); cylindrical shape; horizontal perforation (parallel to the direction face-back).

No. 110: bead, Inv. No. F0715A (Drawing No. 0456). Complete; faience; moulded. 0.77 x 0.23 cm; colour: 5Y 8/1 white; cylindrical shape; perforation: 2.5 mm. *Find No. 010.*

No. 111: bead, Inv. No. F0837A (Drawing No. 0930). Complete; shell (*Ciprea albina*). 1.30 x 0.50 x 1.80 cm. Function: female fertility amulet.

Tool

No. 112: grinding stone (Fig. 3:7), Inv. No. F0987A (before Inv. No. F0987B. Drawing No. 0960). Complete; granite rock. Weight: 492.00 gr. 7.00 x 6.70 x 0.60 cm. Eroded. Wear marks: striations.

Weight

No. 113: net weight, Inv. No. F0789A. Fragmentary; lead; melted. 1.70 x 1.30 x 1.42; U-shape. Function: fishing. *Find No. 044.*

Objects of unknown use

No. 114: fragment of an object, Inv. No. F0528A. Bronze. 1.60 x 0.70 x 0.50 cm. *Find*

No. 017.

No. 115: fragment of an object, Inv. No. F0550A. Bronze. 1.40 x 0.90 x 0.50 cm. *Find No. 038.*

No. 116: fragment of an object, Inv. No. F0657A. Bronze. *Find No. 011.*

No. 117: fragment of an object, Inv. No. F0834A. Bronze.

No. 118: fragment of an object, Inv. No. F0848A. Bronze. 1.00 x 0.50 cm.

No. 119: fragment of an object, Inv. No. F0858A. Bronze. 1.00 x 1.00 cm.

Product

No. 120: faience slag, Inv. No. F0307A.

No. 121: slag, Inv. No. F0815A.

No. 122: slag, Inv. No. F0844A.

No. 123: faience slag, Inv. No. F1058A.

No. 124: flake (Fig. 3:7), Inv. No. F1103A (before Inv. No. F0940B. Drawing No. 0931) Fragmentary; chert; colour: very pale brown. 700 x 6.70 x 0.60 cm. Manufacture technique: flaking. Characteristics: faceted butt, 2.50 x 0.70 cm.

No. 125: flake, Inv. No. F1104A (before Inv. No. F0941B). Fragmentary; chert. 0.40 cm thick. Manufacturing technique: flaking. Characteristics: fragmentary flake with cortex remains.

Raw material

No. 126: bitumen, Inv. No. F0801A.

L0050 = L0052 (Fig. 4)

I.- Pottery

a) Egyptian pottery

Nile silt clay

Fine ware

Egyptian painted ware,

Black on Red slip ware

No. 1: juglet (Fig. 4:1), Inv. No. P0083A (Drawing No. 0049)

RSMO	Nile E ₂	W ₂	---	ox.	2
------	---------------------	----------------	-----	-----	---

Neck and body fragment; globular type. Md: 6.00 cm; Wd: 0.35 cm; H₁: 3.10+ x cm; H₃: 0.30 + x cm. Surface colour: 2.5YR 6/8 red slip. Break: 2.5YR 2.5/1 reddish black core; 5/8 red oxidation zones. Technical details: throwing lines inside. Decoration: six horizontally painted bands, 1 mm wide, 2.5YR 2.5/1 reddish black. Surface treatment: smoothed on the wheel. *Find No. 012.*

Egyptian household ware

No. 2: bowl (Fig. 4:1). Inv. No. C-0244 [002]

Uncoated	Nile B ₂	W ₂
----------	---------------------	----------------

Rim sherd; inverted direct rim. Rd: 24.00 cm 1/16; Wd: 0.66 cm; H₁: 2.00 + x cm; smoothed on the wheel.

No. 3: bowl (Fig. 4:1). Inv. No. C-0244 [001]

Uncoated	Nile B ₂	W ₂
----------	---------------------	----------------

Rim sherd; everted direct rim. Rd: 24.00 cm 1/32; Wd: 0.73 cm; H₁: 4.00 + x cm; smoothed on the wheel.

No. 4: cup (Fig. 4:1). Inv. No. C-0244 [003]

Uncoated	Nile E ₁	W ₂
----------	---------------------	----------------

Rim sherd; slightly everted direct rim. Rd: 10.00 cm 1/64; Wd: 0.50 cm; H₁: 3.30 + x cm. Throwing lines inside; smoothed on the wheel.

No. 5: cooking pot (Fig. 4:1). Inv. No. C-0244 [004]

Uncoated	Nile E ₁	W ₂
----------	---------------------	----------------

Rim sherd; incurved walls; inverted direct rim. Rd: 12.00 cm 3/32; Wd: 0.66cm; H₁: 7.80 + x cm. Throwing lines inside; smoothed on the wheel.

No. 6: juglet (Fig. 4:1), Inv. No. P0616A (Drawing No. 0251)

Uncoated	Nile B ₂	W ₂	---	ox.	2
----------	---------------------	----------------	-----	-----	---

Rim, neck and shoulder fragment; everted direct rim. Rd: 4.00 cm; Nd: 2.80 cm; Md: 5.00 + x cm; Wd: 1.00 cm; H₁: 4.00 + x cm; H₃: 2.50 + x cm. Surface colour: 10R 7/6 light red. Break: 10R weak red core; 10R 5/6 red oxidation zones. Technical details: throwing lines inside. Eroded.

No. 7: juglet, Inv. No. C-0235 [004]

Uncoated	Nile clay	Ha ₂
----------	-----------	-----------------

Handle fragment. Hd: 1.38 x 1.00 cm; single strap; smoked.

No. 8: pilgrim flask (Fig. 4:1), Inv. No. P0611A (Drawing No. 0249)

Uncoated	Nile E ₂	W ₁	---	ox.	2
----------	---------------------	----------------	-----	-----	---

Rim, neck, body and handle fragment; everted articulated exterior rim. Rd: 2.40 cm; Nd: 2.00 cm; H₁: 4.00 + x cm; H₃: 2.10 cm. Surface colour: 10R 4/6 red. Break: 10R 6/8 light red. Technical details: throwing lines inside. Surface treatment: smoothed on the wheel. Eroded rim; smoked on the rim, neck and part of the body.

No. 9: jar (Fig. 4:1). Inv. No. C-0235 [001]

Uncoated	Nile B ₂ f.	W ₂
----------	------------------------	----------------

Rim sherd; vertical direct rim. Rd: 10.00 cm 3/32; Wd: 0.53 cm; H₁: 3.20 + x cm. Throwing lines inside; smoothed on the wheel.

No. 10: storage jar (Fig. 4:2), Inv. No. P0384A (Drawing No. 0184)

Uncoated	Nile B ₂	W ₁	--	ox.	2
----------	---------------------	----------------	----	-----	---

Incomplete, fragmentary; almost complete body; swelling of the handles; nipple base. Md: 33.00 cm; H₁: 56.00 + x cm; H₂: 21.00 cm. Surface colour: 2.5YR 5/6 red. Break: 2.5YR 7/8 light red. Technical details: throwing lines inside. Surface treatment: smoothed on the wheel.

No. 11: storage jar (Fig. 4:3). Inv. No. C-0244 (2) [001]

Uncoated	Nile B ₂	W ₂
----------	---------------------	----------------

Rim sherd; vertical direct rim. Rd: 20.00 cm 3/32; Wd: 0.67 cm; H₁: 2.50 + x cm. Throwing lines inside; smoothed on the wheel.

No. 12: pot (Fig. 4:3), Inv. No. P0609A (Drawing No. 0249)

RP	Nile E ₂	Ha ₁	Ha	ox.	2
----	---------------------	-----------------	----	-----	---

Base and body fragment; ring base (R₁). Md: 6.00cm; Bd: 3.00 cm 1/2; H₁: 6.50 + x cm; H₂: 2.50 cm. Surface colour: 2.5YR 6/6 light red; 10R 4/6 red slip. Break: 2.5YR 6/6 light red. Technical details: fingerprints inside. Surface treatment: polished, medium lustre. Partially smoked inside.

Pottery with special functions**No. 13: bakery tray** (Fig. 4:3). Inv. No. C-0244 [007]

Uncoated	Nile C ₂	W ₁
----------	---------------------	----------------

Rim sherd; everted direct. Rd: 20.00 cm 3/32; Wd: 1.46 cm; H₁: 3.37 + x cm. Throwing lines inside. A base, Bd: 20.00 cm 3/32.

Body sherds, Nile B₂: 20.00 dm²; Nile E₁: 0.50 dm²; Nile E₂: 0.25 dm².

b) North Sinai/South Palestine pottery**No. 14: amphora**, II.TG 09, body sherds: 2.00 dm².**No. 15: amphora**, II.TG 10, body sherds: 0.10 dm².**c) Imported pottery****Levantine fine ware****No. 16: juglet?** (Fig. 4:3), Inv. No. P0800A (Drawing No. 0951)

BPMO	IV.TG 53	W ₂	---	ox.	3
------	----------	----------------	-----	-----	---

Body sherd. Md: 11.00 cm 1/8; H₁: 0.90 + x cm. Surface colour: 10YR 7/4 very pale brown slip. Break: 10YR 6/4 light yellowish brown. Technical details: throwing lines inside. Decoration: horizontally painted lines, 2.50 mm wide, 10YR 6/1 grey. Surface treatment: polished.

No. 17: amphora, IV.TG 51 (= TD IV.19), body sherds: 0.10 dm².**No. 18: amphora**, = TD IV.08, body sherds: 0.10 dm².**Phoenician household ware****No. 19: amphora** (Fig. 4:3), Inv. No. P0511A (Drawing No. 0230)

Uncoated	IV.TG 37 = IV.Phoen?03	W ₂ + Ha ₂	---	ox.	3
----------	------------------------	----------------------------------	-----	-----	---

Shoulder, handle and body fragment; "torpedo" type. Md: 22.00 cm 5/64; H₁: 11.00 + x cm; Hd: 1.50 x 2.10 cm. Surface colour: 7.5YR 5/2 brown. Break: 7.5YR 6/4 light brown. Technical details: throwing lines inside. Surface treatment: smoothed on the wheel. Overfired.

No. 20: amphora, IV.TG 22 = IV.Phoen?04, body sherds: 0.50 dm².**Aegean fine ware****Black-on-Red I ware?****No. 21: juglet** (Fig. 4:3), Inv. No. P0730A (Drawing No. 0657)

RPMO	VII.TG 45	W ₂	---	ox.	3
------	-----------	----------------	-----	-----	---

Body sherd; globular type. Md: 9.00 cm 7/32; Wd: 0.20 cm; H₁: 5.90 + x cm. Surface colour: 2.5YR 5/8 red slip. Break: 2.5YR 5/8 red. Technical details: throwing lines inside. Decoration: circular painted lines, 0.50 mm wide, and two bands, 4 mm wide, 2.5YR 2.5/1 reddish black. Surface treatment: polished, high lustre.

II.- Finds**Recreation****No. 22: sherd used as a gaming piece**, Inv. No. F1034A. Complete; pottery.**Tool****No. 23: grinding stone** (Fig. 4:4), Inv. No. F0082B (Drawing No. 0171). Complete; diorite. 5.40 x 5.40 x 5.40 cm; colour: light greenish grey. Observations: in the Abu Seifa exhibition room. *Find No. 54.***No. 24: grinding stone** (Fig. 4:4), Inv. No. F0983A (Drawing No. 0956). Complete;

reddish sandstone. Weight: 322 gr. 8.70 x 5.30 x 5.00 cm. Eroded.

Object of unknown use

No. 25: fragment of an object (Fig. 4:4), Inv. No. F0107A (Drawing No. 0170). Bronze; melted. 3.50 x 1.00 x 1.30 cm. Find No. 055.

Product

No. 26: faience slag, Inv. No. F1054A.

L0101

Finds

Weight

No. 1: net weight, Inv. No. F1044A. Fragmentary; lead [U-shape]. Function: fishing.

L0266 (Fig. 5)

I.- Pottery

a) Egyptian pottery

Nile silt clay

Egyptian fine ware

No. 1: pilgrim flask (Fig. 5:1), Inv. No. P1202A (Drawing No. 0901)

RP	Nile E ₂	W ₂ + Ha ₂	---	ox.	2-3
----	---------------------	----------------------------------	-----	-----	-----

Neck fragment and swelling of the handle (single strap). Nd: 2.20 cm; Wd: 0.45 cm; H₃: 3.60 + x cm. Surface colour: 10R 4/6 red slip. Break: 7.5YR 5/4 brown interior; 5YR 5/4 reddish brown exterior. Surface treatment: polished.

Household ware

No. 2: bowl (Fig. 5:1), Inv. No. C-0627 (2) [003]

Uncoated	Nile B ₂	W ₂
----------	---------------------	----------------

Rim sherd; incurved walls; inverted direct rim. Rd: 20.00 cm 1/32; Wd: 0.50 cm; H₁: 2.40 + x cm. Throwing lines outside; smoothed on the wheel. Another, Rd: 20.00 cm 1/16.

No. 3: bowl (Fig. 5:1), Inv. No. C-0627 (2) [001]

Uncoated	Nile B ₂	W ₂
----------	---------------------	----------------

Rim sherd; incurved walls; vertical direct rim. Rd: 20.00 cm 3/32; Wd: 0.80 cm; H₁: 5.20 + x cm. Throwing lines; two grooves below the rim; smoothed on the wheel.

No. 4: cooking pot? (Fig. 5:1), Inv. No. C-0627 (2) [014]

Uncoated	Nile B ₂ s.	W ₂
----------	------------------------	----------------

Rim sherd; inverted direct rim. Rd: 33.00 cm 1/16; Wd: 0.90 cm; H₁: 4.70 + x cm. Throwing lines inside; smoothed on the wheel. Another, Rd: 28.00 cm 1/8.

No. 5: cooking pot (Fig. 5:1), Inv. No. C-0627 (2) [018]

Uncoated	Nile E ₁	W ₂
----------	---------------------	----------------

Rim sherd; vertical direct rim. Rd: 12.00 cm 7/32; Wd: 0.60 cm; H₁: 2.90 + x cm. Throwing lines inside; smoothed on the wheel.

No. 6: jar (Fig. 5:1), Inv. No. C-0627 (2) [005]

Uncoated	Nile B ₂	W ₂
----------	---------------------	----------------

Rim sherd; vertical direct rim. Rd: 16.00 cm 5/32; Wd: 0.70 cm; H₁: 6.70 + x cm. Throwing lines outside; smoothed on the wheel.

No. 7: jar (Fig. 5:1), Inv. No. C-0627 (2) [025]

Uncoated	Nile B ₂ s.	W ₂
----------	------------------------	----------------

Rim sherd; vertical trimmed lip. Rd: 14.00 cm 1/64; Wd: 0.50 cm; H₁: 3.00 + x cm. Throwing lines inside; three groves on the neck; smoothed on the wheel.

No. 8: jar (Fig. 5:1), Inv. No. P1163A (Drawing No. 0518)

Uncoated	Nile B ₂	W ₂	base finished on the wheel	ox.	2
----------	---------------------	----------------	----------------------------	-----	---

Base fragment; pointed base. Md: 14.00 + x cm; Wd: 0.55 cm; H₁: 7.00 + x cm. Surface colour: 5YR 6/4 light reddish brown. Break: 2.5 Y 7/2 light grey core; 2.5YR 5/6 red and 5YR 4/4 reddish brown oxidation zones. Technical details: throwing lines inside. Surface treatment: smoothed on the wheel. Smoked outside.

No. 9: jar, Inv. No. P7059A (before Inv. No. P1256A. Drawing No. 0915)

Uncoated	Nile B ₂	W ₂	base finished on the wheel	ox.	2
----------	---------------------	----------------	----------------------------	-----	---

Base fragment; pointed base. Md: 19.00 + x cm; Wd: 0.85 cm; H₁: 16.00 + x cm. Surface colour: ---. Break: ---. Technical details: made in parts; throwing lines inside and outside; deformed; smoked.

No. 10: storage jar (Fig. 5:2), Inv. No. C-0627 (2) [013]

Uncoated	Nile B ₂ s.	W ₂
----------	------------------------	----------------

Rim sherd; inverted articulated interior and exterior rim, modelled lip. Rd: 22.00 cm 3/32; Wd: 0.90 cm; H₁: 4.40 + x cm. Throwing lines inside; smoothed on the wheel. Another, Rd: 20.00 cm 3/32.

No. 11: storage jar (Fig. 5:2), Inv. No. C-0627 (2) [017]

Uncoated	Nile B ₂ s.	W ₂
----------	------------------------	----------------

Rim sherd; inverted articulated exterior rim, modelled lip. Rd: 22.00 cm 1/8; Wd: 0.60 cm; H₁: 2.20 + x cm. Throwing lines inside; smoothed on the wheel. Others, Nile C₁, Rd: 40.00 cm 5/6. Nile C₂, Rd: 38.00 cm 1/8.

No. 12: storage jar (Fig. 5:2), Inv. No. C-0627 (2) [031]

Uncoated	Nile C ₂	W ₂
----------	---------------------	----------------

Rim sherd; inverted articulated exterior rim, folded lip. Rd: 20.00 cm 3/32; Wd: 0.50 cm; H₁: 3.10 + x cm. Throwing lines inside; smoothed on the wheel.

No. 13: storage jar (Fig. 5:2), Inv. No. C-0627 (2) [012]

Uncoated	Nile B ₂ s.	W ₂
----------	------------------------	----------------

Rim sherd; inverted articulated exterior rim, modelled lip. Rd: 20.00 cm 3/32; Wd: 0.60 cm; H₁: 4.00 + x cm. Throwing lines inside; smoothed on the wheel. Others, Rd: 24.00 cm 3/32, Rd: 30.00 cm 7/32.

No. 14: storage jar (Fig. 5:2), Inv. No. C-0627 (2) [029]

Uncoated	Nile B ₂	W ₂
----------	---------------------	----------------

Rim sherd; inverted articulated exterior rim, folded lip. Rd: 20.00 cm 3/32; Wd: 0.90 cm; H₁: 4.70 + x cm. Throwing lines inside; smoothed on the wheel.

No. 15: storage jar (Fig. 5:2), Inv. No. C-0627 (2) [030]

Uncoated	Nile B ₂ s.	W ₂
----------	------------------------	----------------

Rim sherd; inverted direct rim, folded. Rd: 20.00 cm 3/32; Wd: 0.90 cm; H₁: 3.40 + x cm. Throwing lines inside; smoothed on the wheel.

No. 16: storage jar (Fig. 5:2), Inv. No. C-0627 (2) [019]

Uncoated	Nile B ₂ s.	W ₂
----------	------------------------	----------------

Rim sherd; vertical articulated interior and exterior rim. Rd: 20.00 cm 3/16; Wd: 0.70 cm; H₁: 4.60 + x cm. Throwing lines inside; smoothed on the wheel.

No. 17: storage jar (Fig. 5:2), Inv. No. C-0627 (2) [010]

Uncoated	Nile B ₂ s.	W ₂
----------	------------------------	----------------

Rim sherd; everted rim rolled lip. Rd: 26.00 cm 3/32; Wd: 0.70 cm; H₁: 4.10 + x cm. Throwing lines inside; smoothed on the wheel.

Egyptian marls

Fine ware

No. 18: jar (Fig. 5:2), Inv. No. C-0627 (2) [026]

RP	Marl F	W ₂	base finished on the wheel
----	--------	----------------	----------------------------

Base fragment; ring base (R₃). Bd: 7.50 cm 1/1; Wd: 0.40-1.20 cm; H₁: 7.20 + x cm. Slip: 10R 4/6 red. Throwing lines inside; polished.

Household ware

No. 19: bowl (Fig. 5:2), Inv. No. C-0627 (2) [004]

Uncoated	Marl A ₄	W ₂
----------	---------------------	----------------

Rim sherd; incurved walls; inverted articulated exterior rim. Rd: 14.00 cm 1/16; Wd: 0.60 cm; H₁: 2.20 + x cm. Throwing lines inside; smoothed on the wheel.

No. 20: jar (Fig. 5:2), Inv. No. C-0627 (2) [023]

Uncoated	Marl F	W ₂
----------	--------	----------------

Rim sherd; vertical direct rim. Rd: 13.00 cm 1/16; Wd: 0.50 cm; H₁: 2.90 + x cm. Throwing lines inside; smoothed on the wheel.

Body sherds, Nile B₂: 277.00 dm²; Nile C₂ c.: 11.00 dm².

b) North Sinai/South Palestine pottery

Household ware

No. 21: amphora, II.TG 10, body sherd; handle (eroded).

c) Imported pottery

Levantine fine ware

Bichrome ware

No. 22: bottle (Fig. 5:2), Inv. No. P2023A (Drawing No. 0452)

WSBI	IV.TG 51 (=TD IV.19)	W ₂ + Ha ₂	---	ox.	3
------	----------------------	----------------------------------	-----	-----	---

Neck, handle and body fragment; 2; single strap. Nd: 2.30 cm; Wd: 0.80 cm; H₁: 6.80 + x cm; Hd: 1.00 x 1.00 cm. Surface colour: 7.5YR 7/8 reddish yellow slip. Break: 5YR 7/8 reddish yellow. Technical details: throwing lines inside; made in two halves that then were joined. Decoration: circular painted lines, 10R 4/8 red and 7.5YR 2.5/1 black, and red vertical lines on the handle. Surface treatment: smoothed. Observations: a fragment from L0371.

No. 23: amphora, IV.TG 51 (= TD IV.19), body sherd: 0.10 dm².

No. 24: amphora, IV.TG 53 (= TD IV.09), body sherd: 0.10 dm².

II.- Finds

Religion

No. 25: deity figurine? (Fig. 5:3), Inv. No. F0688A (Drawing No. 0641). Fragmentary; faience; moulded. 0.90 x 1.64 x 0.64 cm; colour: light blue. Back pillar; the head (of a goddess ?) and part of the chest are preserved. *Find No. 020.*

Scarabs and seals

No. 26: scarab (Plate 3), Inv. No. F0629 (Drawing No. 0443; object sketch). Complete; faience; moulded. 2.20 cm x 1.80 cm x 1.10 cm; colour: 10YR 7/2 light grey. Description: on the back carved lines; on the base sunken hieroglyphic signs painted in the bottom rendering *Mn-hpr-r* inside a cartouche, flanked by two falcons with spreading wings; longitudinal perforation (diameter 2 mm). Observations: shaped bead complete. SCA No. 4031. *Find No. 11.*

No. 27: seal?, Inv. No. F0662A. Complete; faience; moulded. 0.27 x 1.77 x 0.79 cm. Description: truncate pyramid shape; incised, flat obverse with a Greek inscription (E)?; perforation: 3.6 mm. *Find No. 003.*

Personal objects

No. 28: ring? (Fig. 5:3), Inv. No. F0694A (Drawing No. 0511). Fragmentary; bronze; melted. 1.80 x 1.90 x 1.50-0.40 cm. Rounded section; broken in two parts. *Find No. 018.*

No. 29: bead, Inv. No. F0627A (Drawing No. 0463). Complete; faience; moulded. D: 0.35 cm; colour: 10YR 7/2 light grey; cylindrical shape; perforation: 1.3 mm. *Find No. 024.*

No. 30: bead (Fig. 5:3), Inv. No. F0660A (Drawing No. 0462). Complete; faience; moulded. 0.50 x 0.20 cm; colour: 10YR 8/1 white. Cylindrical shape; perforation: 2 mm. *Find No. 075.*

No. 31: bead (Fig. 5:3), Inv. No. F0706A (Drawing No. 0456). Complete; faience; moulded. 0.71 x 0.49 cm; colour: 2.5Y 6/2 light brownish grey - 6/3 light yellowish brown. Cylindrical shape; perforation: 2.1 mm. Smoked. *Find No. 069.*

Suspended weights

No. 32: net whorl (Fig. 5:3), Inv. No. F0936A (Drawing No. 0943). Complete; limestone. 5.50 x 2.80 cm. Dome-shaped; three grooves (2 mm wide) for fastening and a vertical perforation (9 mm wide); covered by sand; two fish ribs preserved on the surface. *Find No. 012.*

No. 33: net weight (Fig. 5:3), Inv. No. F0948A (Drawing No. 0946). Complete; limestone. 6.30 x 6.80 x 3.10 cm. *Find No. 080.*

Weights

No. 34: net weight (Fig. 5:4), Inv. No. F0698A (Drawing No. 0511). Complete; lead; melted. 1.40 x 2.10 x 1.90 cm; U-shape. Function: fishing. *Find No. 072.*

No. 35: net weight, Inv. No. F0863A. Fragmentary; lead. Function: fishing. Very small fragment. *Find No. 028.*

Tools

No. 36: tool with marginal cutting edge, Inv. No. F0735A. Complete; chert; colour: very pale brown. 3.10 x 2.40 x 0.40 cm. Primary form: flake. Manufacture technique: knapping.

No. 37: fish hook (Fig. 5:4), Inv. No. F0873A (Drawing No. 0931). Fragmentary; bronze; melted. 1.65 x 0.15 cm; the curved end of the hook is lacking.

No. 38: sharpener, Inv. No. F0969A. Pumice.

No. 39: crucible (Fig. 5:4), Inv. No. F1121A (before Inv. No. P7015A. Drawing No. 0904). Complete; clay; round base. Md: 7.50-8.00 cm; Wd: 1.05 cm; H₁: 3.40 cm. Surface

colour: 5YR 7/4 pink. Technical details: a groove 10 mm wide. Smoked on and by the groove.

Weapon

No. 40: slingstone (Fig. 5:4), Inv. No. F0943A (Drawing No. 0945). Complete; limestone. Weight: 182.00 gr. 4.50 x 4.80 x 4.60 cm roughly round, nearly cubic. *Find No. 015.*

Objects of unknown use

No. 41: fragment of an object, Inv. No. F0656A. Faience. 1.01 x 0.74 x 0.96 cm; part of a wdjat? *Find No. 001.*

No. 42: fragment of an object, Inv. No. F0692A. Faience. 0.81 x 0.70 x 1.05 cm. *Find No. 025.*

No. 43: fragment of an object, Inv. No. F0725A. Bronze. 1.40 x 0.80 x 0.90 cm. *Find No. 073.*

No. 44: fragment of an object, Inv. No. 0768A. Bronze. 1.91 x 1.00 x 0.64 cm. *Find No. 023.*

No. 45: fragment of an object, Inv. No. F0771A. Lead. 1.46 x 1.97 x 0.87 cm. *Find No. 022.*

No. 46: fragment of an object (Fig. 5:4), Inv. No. F0866A (Drawing No. 0930). Fragmentary; iron; melted. 7.00 x 1.00 x 1.30 cm. *Find No. 077.*

Raw material

No. 47: pumice (two fragments), Inv. No. F0933A; no traces of use.

L0290 = L0346

Egyptian pottery

No. 1: jar, Inv. No. C-0653 [001], rim sherd, Nile B₂, eroded.

Body sherds, Nile B₂: 2.00 dm².

L0316 (Fig. 6)

a) Egyptian pottery

Nile silt clay

Household ware

No. 1: jar (Fig. 6), Inv. No. C-0452 [002]

Uncoated	Nile B ₂	W ₂
----------	---------------------	----------------

Rim sherd; everted direct rim. Rd: 10.00 cm 3/16; Wd: 0.50 cm; H₁: 3.25 + x cm. Throwing lines inside; smoothed on the wheel; eroded.

No. 2: storage jar (Fig. 6), Inv. No. C-0452 [001]

Uncoated	Nile B ₂	W ₂
----------	---------------------	----------------

Rim sherd; inverted articulated exterior rim, folded lip. Rd: 30.00 cm 3/32; Wd: 1.40 cm; H₁: 5.75 + x cm. Smoothed on the wheel; eroded; smoked inside.

Body sherds, Nile B₂: 2 dm².

L0319 = L0211 (Fig. 7)

I.- Pottery

a) Egyptian pottery

Nile silt clay**Household ware****No. 1: bowl** (Fig. 7), Inv. No. C-0309 [004]RS | Nile B₂ | W₂Rim sherd; everted direct rim. Rd: 32.00 cm 3/32; Wd: 0.67 cm; H₁: 3.47 + x cm; red slipped; throwing lines inside; smoothed on the wheel.**No. 2: jar** (Fig. 7), Inv. No. C-0309 [009]Uncoated | Nile B₂ | W₂Rim sherd; vertical direct rim. Rd: 18.00 cm 3/32; Wd: 0.70 cm; H₁: 2.00 + x cm; throwing lines inside; smoothed on the wheel. Others, Rd: 10.00 cm 5/32, Rd: 11.00 cm 1/16.**No. 3: jar** (Fig. 7), Inv. No. C-0309 [006]RS | Nile B₂ | W₂Rim sherd; slightly everted direct rim. Rd: 12.00 cm 1/8; Wd: 0.33 cm; H₁: 2.44 + x cm. Surface treatment: red slipped outside. Decoration: exterior surface modelled.**No. 4: jar** (Fig. 7), Inv. No. C-0309 [005]Uncoated | Nile B₂ | W₂Rim sherd; slightly everted direct rim. Rd: 10.00 cm 1/8; Wd: 0.70 cm; H₁: 2.28 + x cm; throwing lines inside; smoothed on the wheel. Another, Rd: 9.00 cm 3/16.**Body sherds**, Nile B₂: 10 dm²; Nile C₂: 2.50 dm².**b) North Sinai/South Palestine pottery****Household ware****No. 5: amphora**, Inv. No. C-0309, II.TG 09, body sherd: 0.80 dm².**No. 6: amphora**, Inv. No. C-0309, II.TG 10, body sherd.**c) Imported pottery****Levantine fine ware****Bichrome ware****No. 7: jar** (Fig. 7), Inv. No. P0387B (Drawing No. 0195)WPBI | IV.TG 01 | W₂ + Ha₂ | --- | ox. | 3Incomplete, fragmentary; mended. Bd: 9.00 cm; Md: 25.00 cm; Hd: 2.00 x 4.00 cm; H₁: 25.00 + x cm; H₂: 15.00 cm. Surface colour: 7.5YR 7/4 pink slip. Break: 7.5YR 6/4 light brown. Decoration: horizontally painted bands, 10R 3/6 dark red, 1.10 cm wide; 10R 2.5/1 reddish black, 1 and 3 cm wide on the body at the major diameter; vertical red zigzag lines framed by vertical black lines, opposite to handle; 2 swastikas on shoulder; black band on the base and on the neck. Surface treatment: polished, medium lustre. Observations: in the Abu Seifa exhibition room.**Levantine household ware****No. 8: amphora**, Inv. No. C-0309, IV.TG 11, body sherds: 1.00 dm².**No. 9: amphora**, Inv. No. C-0309, IV.TG 51 (=TD IV.19), body sherds: 0.10 dm².**II.- Finds****No. 10: plaque** (Plate 4), Inv. No. F0235 (Drawing No. 0160). Complete; diorite. 1.00 x 1.40 x 0.45 cm; colour: dark grey. Description: rectangular shaped with rounded angles; carved inscriptions on both sides. On the obverse: on top *R^c* (the winged *R^c*) and below the *irt* eye and *Imn* (the stick + *i* = the maat feather + *R^c*). On the reverse: on top *Imn* (the stick

+ *i* = the maat feather + *R*^c), and below the *drt* hand and *nb*; perforation on longitudinal/vertical axis. Observations: found in the sediment inside a Levantine vessel (Inv. No. P0387B). SCA No.1009.

Personal objects

No. 11: beads (two) (Fig. 7), Inv. No. F0931A (Drawing No. 0940). Complete; shell (*Ciprea albina*). 1) 1.00 x 0.60 cm; 2) 0.80 x 0.50 cm; a perforation to be used as beads. Function: female fertility amulet.

Products

No. 12: faience slag, Inv. No. F0022A.

No. 13: faience slag, Inv. No. F1056A.

L0345 (Fig. 8)

Egyptian pottery

Nile silt clay

Household ware

No. 1: jar (Fig. 8), Inv. No. C-9002 [002]

Uncoated	Nile B ₂	W ₂
----------	---------------------	----------------

Rim fragment; vertical direct rim. Rd: 10.00 cm 1/8; Wd: 0.65 cm .

No. 2: handle, Nile B₂, Hd: 1.90 x 2.30 cm.

Pottery with special functions

No. 3: lid (Fig. 8), Inv. No. C-9002 [001]

Uncoated	Nile B ₂	W ₂
----------	---------------------	----------------

Rim sherd; everted direct rim. Rd: 26.00 cm 1/16; smoked.

L0352 (Fig. 9)

I.- Pottery

a) Egyptian pottery

Nile silt clay

Household ware

No. 1: bowl (Fig. 9:1), Inv. No. C-0609 (2) [003]

Uncoated	Nile B ₂	W ₂
----------	---------------------	----------------

Rim sherd; incurved walls, inverted directed rim. Rd: 14.00 cm 1/16; Wd: 0.65 cm; H₁: 2.50 + x cm. Throwing lines outside; smoothed on the wheel; eroded.

No. 2: bowl (Fig. 9:1), Inv. No. C-0609 (2) [004]

Uncoated	Nile B ₂	W ₂
----------	---------------------	----------------

Rim sherd; everted articulated exterior rim; modelled lip. Rd: 20.00 cm 3/32; Wd: 0.50 cm; H₁: 1.60 + x cm. Throwing lines outside; smoothed on the wheel; eroded.

No. 3: juglet, Inv. No. C-0609 (2) [010]

Uncoated	Nile B ₂	W ₂
----------	---------------------	----------------

Body sherd, incurved convex sided walls. Md: 4.00 cm; Wd: 0.90 cm; H₁: 4.10 + x cm. Throwing lines outside; smoothed on the wheel.

No. 4: jar (Fig. 9:1), Inv. No. C-0609 (2) [001]

Uncoated	Nile B ₂	W ₂
----------	---------------------	----------------

Rim sherd; vertical direct rim. Rd: 12.00 cm 1/16; Wd: 0.70-0.85 cm; H₁: 3.20 + x cm; Throwing lines inside; smoothed on the wheel; eroded. Another, Rd: 10.00 cm 1/16.

No. 5: jar (Fig. 9:1), Inv. No. C-0609 (2) [005]

Uncoated	Nile B ₂	W ₂
----------	---------------------	----------------

Rim sherd; everted direct rim. Rd: 16.00 cm 1/8; Wd: 1.00 cm; H₁: 6.35 + x cm. Throwing lines inside; smoothed on the wheel; eroded.

No. 6: storage jar (Fig. 9:1), Inv. No. C-0609 (2) [009]

Uncoated	Nile B ₂	W ₂
----------	---------------------	----------------

Rim sherd; inverted articulated interior and exterior rim, round lip. Rd: 20.00 cm 3/32; Wd: 0.90 cm; H₁: 3.70 + x cm. Throwing lines inside; smoothed on the wheel; eroded.

No. 7: storage jar (Fig. 9:1), Inv. No. P1102A₁₋₂ (Drawing No. 0917)

Uncoated	Nile B ₂	W ₂	---	ox.	2
----------	---------------------	----------------	-----	-----	---

Rim and body fragments; folded rim. Rd: 30.00 cm 3/32; Md: 28.00 + x cm; Wd: 0.70-1.00 cm; H₁: 5.00 + x + 22.00 + x cm. Surface colour: 5YR 5/3 reddish brown. Break: 2.5YR 4/8-5/6 red. Technical details: made in parts. Surface treatment: smoothed on the wheel.

No. 8: handle, Inv. No C-0609 (2) [012] Nile B₂, Hd: 4.20 x 3.30 cm. Another, Hd: 1.20 x 1.00 cm.

Pottery with special functions

No. 9: lid (Fig. 9:2), Inv. No. C-0609 (2) [008]

Uncoated	Nile B ₂	W ₂
----------	---------------------	----------------

Rim sherd; everted direct rim. Rd: 22.00 cm 1/16; Wd: 0.80 cm; H₁: 3.80 + x cm. Throwing lines inside; smoothed on the wheel; eroded and salt incrustated. Another, Rd: 24.00 cm 3/32.

No. 10: lid (Fig. 9:2), Inv. No. C-0609 (2) [006]

Uncoated	Nile B ₂	W ₂
----------	---------------------	----------------

Rim sherd; everted articulated exterior rim; modelled lip. Rd: 22.00 cm 1/16; Wd: 0.80 cm; H₁: 2.20 + x cm. Throwing lines inside; smoothed on the wheel; eroded; smoked inside.

Body sherds, Nile B₂: 10.50 dm²; Nile C₁: 2.20 dm²; Nile C₂: 2.00 dm²; Marl A₄: 0.30 dm².

b) North Sinai/South Palestine pottery

Household ware

No. 11: amphora, Inv. No. C-0609 (2), II. TG 08, body sherds, 0.20 dm².

c) Imported pottery

Levantine household ware

No. 12: amphora, Inv. No. C-0609 (2) [013], swelling of a handle, IV.TG 53 (=TD IV.09), Hd: 3.75 x 2.10 cm.

No. 13: amphora, Inv. No. C-0609 (2), IV.TG 51 (=TD IV.19) body sherds, 0.20 dm².

Cypriote household ware

No. 14: amphora, Inv. No. C-0609 (2), VI.TG 44, body sherds, 0.10 dm².

II.- Finds**Personal object**

No. 15: bead, Inv. No. F0727A (Drawing No. 0463). Complete; faience; moulded. 0.32 x 0.10 cm; colour: 10YR 8/1 white; cylindrical shape; perforation: 1.5 mm. *Find No. 018.*

Tools

No. 16: fish hook? (Fig. 9:2), Inv. No. F0864A (Drawing No. 0931). Fragmentary; bronze; melted. 3.00 x 0.20 cm.

No. 17: fish hook (Fig. 9:2), Inv. No. F0872A (Drawing No. 0931). Fragmentary; bronze; melted. 2.00 x 0.30 cm.

No. 18: slingstone (Fig. 9:2), Inv. No. F0945A (Drawing No. 0945). Complete; limestone. Weight: 225 grs. 4.80 x 5.00 cm; nearly spheric. *Find No. 058.*

Weight

No. 19: net weight, Inv. No. F0862A. Lead; melted. Function: fishing. Very small fragment.

L0353 (Fig. 10)**Finds****Suspended weights**

No. 1: loom weight (Fig. 10), Inv. No. F0638A (Drawing No. 0936). Fragmentary; clay. 8.56 x 3.92 x 5.26 cm; 7.5YR 5/4 brown; perforation: broken. *Find No. 001.*

No. 2: loom weight (Fig. 10), Inv. No. F0641A (Drawing No. 0384). Fragmentary; unbaked clay. 9.50 x 4.39 x 4.64 cm; colour: 7.5YR 5/3 brown; perforation: broken.

L0356 (Fig. 11)**I.- Pottery****a) Egyptian pottery****Nile silt clay****Egyptian fine ware**

No. 1: juglet (Fig. 11:1), Inv. No. P1110A (Drawing No. 0518)

RP	Nile E ₂ fine	W ₂ + Ha ₂	W	ox.	2-3
----	--------------------------	----------------------------------	---	-----	-----

Incomplete, fragmentary; bag-shaped type; rounded base; single strap. Nd: 3.80 cm; Md: 8.00 cm; Wd: 0.55 cm; H₁: 9.80 + x cm; H₂: 4.00 cm; Hd: ca. 1.40 x 1.00 cm. Surface colour: 10R 5/6 red slip. Break: 5YR 5/4 reddish brown. Technical details: made in parts; base slightly flattened. Surface treatment: polished, low lustre. Smoked inside. *Find No. 034.*

No. 2: juglet (Fig. 11:1), Inv. No. P1092A (Drawing No. 0519)

BP	Nile E ₂	W ₂ + Ha ₂	---	ox.	2
----	---------------------	----------------------------------	-----	-----	---

Complete, fragmentary; everted direct rim. Rd: 4.00-4.60 cm; Md: 6.80 cm; Wd: 0.60 cm; H₁: 11.80 cm; H₂: 3.80 cm; H₃: 3.00 cm. Surface colour: 10YR 7/4 very pale brown slip. Break: 7.5YR 5/2 brown. Surface treatment: polished, low lustre.

Egyptian painted ware**Bichrome ware**

No. 3: jar (Fig. 11:1), Inv. No. P1201A (Drawing No. 0521)

WPBI	Nile B ₂	W ₂	---	ox.	2-3
------	---------------------	----------------	-----	-----	-----

Rim sherd, 1/32 preserved; vertical direct rim. Rd: 12.00 cm; Wd: 0.45 cm; H₁: 2.50 + x

cm. Surface colour: 10YR 8/3 very pale brown; 5YR 7/4 pink slip. Break: 2.5YR 5/6 red. Technical details: throwing lines inside. Decoration: four horizontally painted bands, 4 mm wide, black-red-black (2.5YR 4/1 dark reddish grey and 10R 4/6 red). Surface treatment: polished, low lustre. The slip covers also the rim inside. *Find No. 071.*

II.- Finds

Suspended weights

No. 4: loom weight (Fig. 11:1), Inv. No. F0605A (Drawing No. 0386). Fragmentary; unbaked clay; hand-made. 7.50 x 6.23 x 3.22 cm; colour: 7.5YR 3/2. Perforation: 1.10 cm. *Find No. 051.*

No. 5: loom weight (Fig. 11:2), Inv. No. F0607A (Drawing No. 0381). Complete; clay; hand-made. 9.82 x 9.35 x 4.94 cm; colour: 5YR 6/4 and 3/2. Perforation: 0.88 cm. *Find No. 047.*

No. 6: loom weight (Fig. 11:2), Inv. No. F0608A (Drawing No. 0382). Complete; unbaked clay; hand-made. 9.83 x 10 x 4.89 cm; colour: 10YR 3/1. Perforation: 0.85 cm. *Find No. 054.*

No. 7: loom weight, Inv. No. F0611A (Drawing No. 0373). Complete; unbaked clay; hand-made. 10.42 x 10.67 x 5.55 cm; colour: 5YR 4/2. Perforation: 1.89 cm. *Find No. 048.*

No. 8: loom weight, Inv. No. F0613A (Drawing No. 0375). Fragmentary; unbaked clay; hand-made. 9.49 x 10.12 x 4.85 cm; colour: 10YR 4/2 dark greyish grey. Perforation: 1.97 cm. *Find No. 053.*

No. 9: loom weight (Fig. 11:2), Inv. No. F0617A (Drawing No. 0375). Complete; clay; hand-made. 9.95 x 9.89 x 5.43 cm; colour: 2.5YR 5/6 and 5YR 4/4. Perforation: 1.40 cm. *Find No. 034.*

No. 10: loom weight (Fig. 11:3), Inv. No. F0618A (Drawing No. 0370). Complete; unbaked clay; hand-made. 11.08 x 10.33 x 5.41 cm; colour: 7.5YR 4/1. Perforation: 2.10 cm. *Find No. 052.*

No. 11: loom weight (Fig. 11:3), Inv. No. F0620A (Drawing No. 0371). Mended; unbaked clay; hand-made. 9.37 x 9.38 x 5.3 cm; colour: 10YR 5/1. Perforation: 0.78 cm. *Find No. 050.*

No. 12: loom weight (Fig. 11:3), Inv. No. F0621A (Drawing No. 0377). Complete; clay; hand-made. 9.24 x 9.01 x 4.75 cm; colour: 5YR 6/4. Perforation: 0.85 cm. *Find No. 037.*

No. 13: loom weight (Fig. 11:3), Inv. No. F0624A (Drawing No. 0376). Complete; clay; hand-made. 9.43 x 9.37 x 4.67 cm; colour: 2.5YR 5/4. Perforation: 0.73 cm. *Find No. 039.*

No. 14: loom weight (Fig. 11:4), Inv. No. F0626A (Drawing No. 0374). Complete; clay; hand-made. 9.93 x 9.89 x 4.55 cm; colour: 5 YR 6/6. Perforation: 0.75 cm. *Find No. 033.*

No. 15: loom weight (Fig. 11:4), Inv. No. F0628A (Drawing No. 0380). Complete; clay; hand-made. 10.08 x 9.9 x 4.85 cm; colour: 5YR 5/6. Perforation: 0.77 cm. *Find No. 045.*

No. 16: loom weight (Fig. 11:4), Inv. No. F0631A (Drawing No. 0939). Fragmentary; clay; hand-made. 7.82 x 4.03 x 4.99 cm; colour: 10R 5/6. Perforation: broken. *Find No. 040.*

No. 17: loom weight (Fig. 11:4), Inv. No. F0633A (Drawing No. 0939). Fragmentary; clay; hand-made. 4.69 x 4.29 x 5.63 cm; colour: 5YR 5/3. Perforation: broken. *Find No. 035.*

No. 18: loom weight (Fig. 11:4), Inv. No. F0635A (Drawing No. 0936). Fragmentary; clay; hand-made. 1) 7.89 x 4.90 x 3.45; 2) 7.25 x 3.88 x 3.21 cm; colour: 10YR 5/1. Perforation: broken. *Find No. 044.*

No. 19: loom weight, Inv. No. F0708A. Fragmentary; unbaked clay; hand-made. 1) 6.20 x 4.79 x 3.64; 2) 2.96 x 2.82 x 3.73 cm; colour: 7.5YR 4/1. Perforation: not determinate. *Find No. 038.*

Personal object

No. 20: bead (Fig. 11:4), Inv. No. F0702A (Drawing No. 0463). Complete; faience; moulded. 0.67 x 0.19 cm; colour: 5Y 8/1 (white); cylindrical shape; perforation: 2 mm. *Find No. 042.*

Tool

No. 21: sharpener (Fig. 11:5), Inv. No. F0870A (Drawing No. 0930). Sandstone; sharpener by use. 6.50 x 3.20 x 5.0 cm; two incised grooves on the surface. *Find No. 036.*

Structure G

In Square BA/41, two roughly concentric shallow ditches circumscribed a circular area about 2 m in diameter (Plan II and Plate IV). The outer ditch was narrow (about 10 cm wide) and the inner, less clearly defined, is 20 to 35 cm wide. In the southern boundary, an outer ditch 10 cm wide could also be noted. Twelve circular or oval pits between 20 and 30 cm wide were found inside the feature, and two more outside but very close to it. Since a pottery vessel was found inside one of the inner ones, some of these pits may have been substitutes for furniture. But the rest of them were empty and they are too numerous, so they may indicate the former position of posts which -as valuable possessions- were reclaimed when the light building was removed or abandoned.

In the centre of the circular area, a concentration, about 1.20 m across, of bones and charcoal, along with some pottery, several small finds and a net sunk, was identified as floor **L0273**.

That this structure was a tent, that is, a mobile shelter, is suggested by the roundness of the layout and the possible postholes. The ditches and ridges in the sand L0266 could have helped to sustain the blind and to prevent drafts. Since floor L0273 is shallow, no formal arrangements were made for the hearth and no oxidation was observed in the sand beneath. Structure G seems to have been short-lived and so, different in nature and perhaps in function from neighbouring Building A.

Archaeological material**L0273 (Fig. 12)****Pottery****a) Egyptian pottery,**

Nile silt clay,

*household ware***No. 1: jar** (Fig. 12), Inv. No. C-0622 [001]

Uncoated	Nile B ₂	W ₂
----------	---------------------	----------------

Rim sherd; vertical direct rim. Rd: 10.00 cm 1/8; Wd: 0.70 cm; H₁: 5.75 + x cm; smoked. Another, Rd: 10.00 cm 3/32.

Body sherds, Nile B₂, and Nile B₂/C₁: 13.00 dm², Nile C₂: 0.20 dm², Marl F v.s.: 0.10 dm².

b) Imported pottery,*Levantine household ware***No. 2: amphora**, Inv. No. C-0622, IV.TG 51 (= TD IV.19), body sherd, 0.10 dm².

LEVEL III: L0289 (Fig. 13)

After the burning of Building A, this part of the site remained unoccupied for some time, as the accumulation of dark, carbonaceous and featureless *L0289* indicates. In the main, it is a thinly layered unity resulting from the washing out of remains of former occupations. Laterally, it changes to a massive fill that includes many sherds in angular position, an indication of very few, if any, human transit (Plate II).

Archaeological material**I.- Pottery****a) Egyptian pottery****Nile silt clay*****Fine ware***

No. 1: pot (Fig. 13:1), Inv. No. C-0635 [013]

RP	Nile E ₂	W ₂
----	---------------------	----------------

Rim sherd; everted articulated exterior rim; flat lip. Rd: 10.00 cm 1/8; Wd: 0.45 cm; H₁: 2.10 + x cm. Throwing lines inside; polished on the rim (10R 5/6 red); eroded outside.

No. 2: pot, Inv. No. C-0416 [024]

RP	Nile B ₂	W ₂
----	---------------------	----------------

Body sherd; Md: 16.00 cm; Wd: 0.70 cm; H₁: 3.00 + x cm. Throwing lines inside; vertically burnished.

No. 3: pot (Fig. 13:1), Inv. No. C-0635 [009]

RP	Nile B ₂	W ₂
----	---------------------	----------------

Rim sherd; everted articulated exterior rim, modelled lip. Rd: 6.00 cm 1/8; Wd: 0.35 cm; H₁: 1.10 + x cm. Throwing lines inside; burnished; eroded.

Household ware

No. 4: bowl (Fig. 13:1), Inv. No. C-0619 [008]

Uncoated	Nile B ₂	W ₂
----------	---------------------	----------------

Rim sherd; inverted direct rim. Rd: 21.00 cm 3/32; Wd: 0.70 cm; H₁: 2.70 + x cm. Throwing lines inside; smoothed on the wheel.

No. 5: bowl (Fig. 13:1), Inv. No. C-0416 [006]

Uncoated	Nile B ₂	W ₂
----------	---------------------	----------------

Rim sherd; inverted symmetrical rim, trimmed lip. Rd: 20.00 cm 7/64; Wd: 0.80 cm; H₁: 3.00 + x cm. Smoothed on the wheel.

No. 6: bowl, Inv. No. C-0635 [022]

Uncoated	Nile B ₂	W ₂
----------	---------------------	----------------

Rim sherd; everted direct rim, round lip. Rd: 20.00 cm 3/32; H₁: 1.60 + x cm. Throwing lines inside; eroded. Others, Rd: 18.00 cm 1/16, Rd: 20.00 cm 1/16, Rd: 20.00 cm? 3/64, Rd: 20.00 cm 1/8, Rd: 24.00 cm 1/32.

No. 7: bowl (Fig. 13:1), Inv. No. C-0619 [001]

Uncoated	Nile B ₂	W ₂
----------	---------------------	----------------

Rim sherd; everted articulated exterior rim, modelled lip. Rd: 32.00 cm 1/16; Wd: 1.00 cm; H₁: 2.80 + x cm. Throwing lines inside; smoothed on the wheel. Others, Rd: 18.00 cm? 1/64, Rd: 20.00 cm 1/8.

No. 8: bowl (Fig. 13:1), Inv. No. C-0635 [020]Uncoated Nile C₁ W₂

Rim sherd; everted articulated exterior rim, bevelled lip. Rd: 22.00 cm 1/16; Wd: 0.60 cm; H₁: 2.90 + x cm. Throwing lines inside; smoothed on the wheel; eroded. Another, Rd: 18.00 cm 1/16.

No. 9: cup (Fig. 13:1), Inv. No. C-0416 [010]Uncoated Nile B₂ f. W₂

Rim sherd; vertical direct rim. Rd: 10.00 cm 1/64; Wd: 0.50 cm; H₁: 4.45 + x cm. Throwing lines inside; eroded. Another, Rd: 6.00 cm? 3/32, eroded rim.

No. 10: cup, Inv. No. C-0635 [024]Uncoated Nile B₂ W₂ base finished on the wheel

Base fragment; pointed base. Wd: 0.70 cm; H₁: 1.90 + x cm. Throwing lines inside; smoothed on the wheel; eroded. Others, 3 bases.

No. 11: jar (Fig. 13:1), Inv. No. C-0619 [003]Uncoated Nile B₂ W₂

Rim sherd; inverted direct rim, round lip. Rd: 12.00 cm 3/32; Wd: 0.70 cm; H₁: 3.60 + x cm. Throwing lines inside; smoothed on the wheel. Others, Rd: 10.00 cm 1/8, Rd: 12.00 cm 3/32.

No. 12: jar, Inv. No. C-0635 [003]Uncoated Nile B₂ fine W₂

Rim sherd; inverted direct rim. Rd: 8.00 cm 3/32; Wd: 0.35-0.50 cm; H₁: 2.70 + x cm. Throwing lines inside; smoothed on the wheel.

No. 13: jar (Fig. 13:1), Inv. No. C-0635 [017]Uncoated Nile B₂ W₂

Rim sherd; vertical direct rim, round lip. Rd: 12.00 cm 3/32; Wd: 0.55 cm; H₁: 3.00 + x cm. Throwing lines inside; smoothed on the wheel; eroded. Others, Rd: 10.00 cm 1/8, Rd: 10.00 cm 3/32, Rd: 10.00 cm 5/32. Nile C₁, Rd: 12.00 cm 1/4.

No. 14: jar (Fig. 13:1), Inv. No. C-0635 [021]Uncoated Nile B₂ W₂

Rim and neck fragment; everted direct rim, round lip. Rd: 5.00 cm 7/32; Wd: 0.55 cm; H₁: 2.40 + x cm. Throwing lines inside; smoothed on the wheel; eroded rim.

No. 15: jar (Fig. 13:1), Inv. No. C-0635 [004]Uncoated Nile B₂ W₂

Rim sherd; everted direct rim. Rd: 12.00 cm 1/8; Wd: 0.60 cm; H₁: 4.00 + x cm. Throwing lines inside; smoothed on the wheel; eroded lip. Others, Rd: 12.00 cm 3/32. Nile C₁, Rd: 10.00 cm 3/32.

No. 16: jar, Inv. No. C-0635 [027]Uncoated Nile B₂ Ha₂

Handle fragment; vertical loop handle. Hd: 2.00 x 2.60 cm; single strap. Eroded. Another, Hd: 2.50 x 1.50 cm, Nile E₂.

No. 17: storage jar (Fig. 13:1), Inv. No. C-0416 [021]Uncoated Nile B₂ W₂

Rim sherd; inverted articulated interior and exterior rim, modelled lip. Rd: 32.00 cm 1/16; Wd: 0.90 cm; H₁: 4.70 + x cm. Throwing lines inside; smoothed on the wheel. Another, Rd: 24.00 cm 1/16.

No. 18: storage jar (Fig. 13:1), Inv. No. C-0416 [020]

Uncoated	Nile C ₁	W ₂
----------	---------------------	----------------

Rim sherd; inverted articulated exterior rim, round lip. Rd: 24.00 cm 1/8; Wd: 0.60 cm; H₁: 5.00 + x cm. Throwing lines inside; smoothed on the wheel.

No. 19: storage jar (Fig. 13:1), Inv. No. C-0635 [014]

Uncoated	Nile C ₁	W ₂
----------	---------------------	----------------

Rim sherd; everted articulated exterior rim, modelled lip. Rd: 24.00 cm 3/32; Wd: 1.35 cm; H₁: 4.30 + x cm. Throwing lines inside; smoothed on the wheel; eroded.

No. 20: storage jar, Inv. No. C-0635 [015]

Uncoated	Nile C ₁	W ₂
----------	---------------------	----------------

Rim sherd; articulated exterior rim, round lip. Rd: 22.00 cm 1/16; Wd: 1.10 cm; H₁: 2.50 + x cm. Throwing lines inside; smoothed on the wheel.

No. 21: storage jar, Inv. No. C-0416 [023]

Uncoated	Nile B ₂	W ₁	W
----------	---------------------	----------------	---

Base fragment (1/1); round base. Wd: 1.40 cm; H₁: 2.50 + x cm. Throwing lines inside; smoothed on the wheel.

Pottery with special functions

No. 22: lid (Fig. 13:1), Inv. No. C-0635 [005]

Uncoated	Nile B ₂	W ₂
----------	---------------------	----------------

Rim sherd; everted direct rim, round lip. Rd: 20.00 cm 1/8; Wd: 0.90 cm; H₁: 4.90 + x cm. Throwing lines inside; smoothed on the wheel; smoked inside. Another, Rd: 22.00 cm 1/64.

No. 23: bakery tray, Inv. No. C-9043 [001]

Uncoated	Nile C ₂	W ₁	Ha
----------	---------------------	----------------	----

Complete, fragmentary; everted direct rim, round lip; flat base. Rd: 18.00 cm 1/8; Wd: 1.94 cm; H₁: 3.69 cm. VI: 488. Smoothed.

No. 24: tray, Inv. No. C-0416 [028]

Uncoated	Nile C ₂	Ha ₁
----------	---------------------	-----------------

Fragment. Wd: 2.00 cm.

Body sherds, Nile B₂: 14.00 dm²; Nile C₁: 1.00 dm²; Nile C₂: 1.50 dm²; Marl A₄, Marl F, Marl F v.s., Marl F + limestone, Marl F + ochre.

b) North Sinai/South Palestine pottery

Household ware

No. 25: amphora, Inv. No. C-0635 [029]

Uncoated	II.TG 08	W ₂
----------	----------	----------------

Rim sherd; vertical direct rim, round lip. Rd: 10.00 cm 5/32; eroded rim.

No. 26: amphora (Fig. 13:2), Inv. No. P2006A (Drawing No. 0444)

Coated	II.TG 09	W ₂	---	ox.	2
--------	----------	----------------	-----	-----	---

Rim sherd; vertical direct rim, round lip. Rd: 10.00 cm 1/16; Wd: 1.00 cm; H₁: 2.00 + x cm. Surface colour: 5YR 7/6 reddish yellow slip. Break: 5YR 7/2 pinkish grey insided; 5YR 7/6 reddish yellow outside. Technical details: throwing lines inside and outside. Surface treatment: smoothed on the wheel.

c) Imported pottery

Levantine fine ware

White Painted ware

No. 27: jar (Fig. 13:2), Inv. No. P0806A (Drawing No. 0654)

BPMO	IV.TG 31	W ₂	---	me.	3
------	----------	----------------	-----	-----	---

Rim sherd; trimmed rim. Rd: 10.00 cm 3/16; Wd: 0.40 cm; H₁: 3.20 + x cm. Surface colour: 7.5YR 6/3 light brown slip. Break: 7.5YR 5/1 grey inside; 7.5YR 7/1 light grey outside. Technical details: throwing lines inside. Decoration: a vertically painted band, 21 mm wide, 7.5YR 4/1 dark grey. Surface treatment: polished, low lustre. Smoked.

Bichrome ware

No. 28: jar? (Fig. 13:2), Inv. No. P0787A (Drawing No. 0663)

RPBI	IV.TG 53 (= TD IV.09)	W ₂	---	re.	3
------	-----------------------	----------------	-----	-----	---

Body sherd. Md: 13.00 cm 1/8; Wd: 0.60 cm; H₁: 3.60 + x cm. Surface colour: 7.5YR 7/4 pink slip. Break: 10YR 6/1 grey. Technical details: throwing lines inside. Decoration: a 7.5YR 5/1 grey painted band, 19 mm wide, and four 2.5YR 5/6 red lines, 2 mm wide. Surface treatment: polished.

Levantine household ware

No. 29: amphora (Fig. 13:2), Inv. No. C-0635 [028]

Uncoated	IV.TG 01	W ₂			
----------	----------	----------------	--	--	--

Rim sherd; vertical direct rim, round lip. Rd: 10.00 cm 1/8; Wd: 0.90 cm; H₁: 2.20 + x cm. Throwing lines inside; self slip; eroded.

No. 30: amphora, Inv. No. C-0619, IV.TG 03, body sherds.

No. 31: amphora, Inv. No. C-0619, IV.TG 11, body sherds.

No. 32: amphora, Inv. No. C-0416, IV.TG 23, body sherds.

No. 33: amphora, Inv. No. C-0635, IV.TG 23, body sherds.

No. 34: amphora, Inv. No. C-0635, IV.TG 29, body sherds.

No. 35: amphora, Inv. No. C-0416, IV.TG 36, body sherds.

No. 36: amphora, Inv. No. C-0635, IV.TG 51 (= TD IV.19), body sherds.

No. 37: amphora, Inv. No. C-0635, = TD IV.02, body sherds.

Cypriote fine ware

White Painted ware

No. 38: jar? (Fig. 13:2), Inv. No. P0798A (Drawing No. 0950)

BPMO	VI.TG 40	W ₂	---	ox.	3
------	----------	----------------	-----	-----	---

Body sherd. Md: 11.00 cm 1/8; Wd: 0.65 cm; H₁: 2.70 + x cm. Surface colour: 10YR 7/3 very pale brown slip. Break: 10YR 5/2 greyish brown. Technical details: throwing lines inside. Decoration: two painted lines, 5YR 4/2 dark reddish grey. Surface treatment: polished, low lustre.

Cypriote household ware

No. 39: amphora (Fig. 13:2), Inv. No. P1191A (Drawing No. 0623)

Uncoated	VI.TG 40	W ₂	---	re.	3
----------	----------	----------------	-----	-----	---

Rim sherd; everted direct rim. Rd: 12.00 cm 1/8; Wd: 1.00 cm; H₁: 3.00 + x cm. Surface

colour: 10YR 8/4 very pale brown. Break: 10YR 6/2 light brownish grey. Technical details: throwing lines inside. Surface treatment: smoothed on the wheel.

Aegean fine ware

No. 40: amphora, Inv. No. C-0635, VI.TG 04, body sherds.

No. 41: juglet (Fig. 13:2), Inv. No. P0710A (Drawing No. 0310)

RP	VII.TG 45	W ₂	---	ox.	3
----	-----------	----------------	-----	-----	---

Body sherd. Md: 5.00 cm; Wd: 0.35 cm; H₁: 2.50 + x cm. Surface colour: 7.5YR 7/3 pink; slip: 2.5YR 7/6 light red. Break: 7.5YR 7/3 pink. Technical details: throwing lines inside. Surface treatment: polished, very high lustre.

Aegean household ware

No. 42: amphora, Inv. No. C-0635, VII.TG 46 (Chian), body sherds.

II.- Finds

Objects of unknown use

No. 43: fragments of an object, Inv. No. F0458A. Bronze. 1.40 x 0.60 cm. *Find No.* 033.

No. 44: fragment of an object, Inv. No. F0464A. Bronze; very small fragment. *Find No.* 035.

Personal objects

No. 45: bead, Inv. No. F0654A. Fragmentary; faience; moulded. 0.27 x 0.26 cm; colour: turquoise; cylindrical shape. *Find No.* 004.

No. 46: bead, Inv. No. F0714A (Drawing No. 0457). Complete; faience; moulded. 0.50 x 0.36 cm; colour: 2.5YR 8/1 white; cylindrical shape; perforation: 2 mm. *Find No.* 009.

No. 47: bead (Fig. 13:2), Inv. No. F0721A (Drawing No. 0459). Complete; faience; moulded. 0.80 x 0.30 cm; colour: 10YR 7/2 light grey; cylindrical shape; perforation: 2.4 mm.

Product

No. 48: metal slag, Inv. No. F0463A.

LEVEL IV: Building B

1.- General description

Building B (Plan III and Plate III), a private? mud brick construction, was erected directly on L0289, without foundation trenches. It has been exposed in its entirety, with the exception of the NE and NW external corners. Most of the squares in which it is included (BA/43, BB/43, BA/42, BB/42 and BC/42) were in fact test pits aimed at establishing a first stratigraphy and at trying different excavation strategies in an unknown site.

Building B is rectangular in layout, measuring about 13 m x 9 m, with the main axis oriented ESE-WNW. It comprises six rooms and a small magazine. Moreover, a bricked floor surface (L0169) beside the badly preserved NE side may be the remains of a former porch or yard.

The following table contains the measures and some properties of the rooms (which are identified from N to S and from E to W):

Room	Dimensions (m)	Notes
B-1	4 x 1.5	N and W wall are almost destroyed. Floor: L0303.
B-2	4 x 1.3	Floor L0283 = L0271
B-3	3.5 x 2.1	It includes hearth/oven L0176 . In the carbonaceous interior of this feature, a big sherd was found (part of a lid, Inv. No. C-0444 [003]). Beside its S side, there is a mud brick platform. Some mud bricks forming part of this feature are almost white, in contrast with the rest of the fabric, so that a minor refurbishing seems to have taken place here. Floor: L0250 . The limited working space during excavation prevented us from separating L0250 from underneath L0263 = L0222 , which comprises untrodden charcoals.
B-4	4 x 2.5	This room was disturbed in part by ditches (perhaps the remains of later structures), which were filled by L0029 and L0038 . There is a succession of floors: the older one (L0283) was covered by <i>muna</i> L0307, which is another floor preparation and on which floor L0306 was formed by human frequentation. L0034 could include later materials along with floor materials.
B-5	5 x 3.4	Floor L0271 = L0060
B-6	3.9 x 2.6	Floor L0017 . It includes mud brick hearth/oven L0013 . Length and width of the bigger mud bricks: 31 x 17 cm, 34 x 14 cm, 34 x 11 cm. Some mud bricks seem to have been reused fragments, since they are irregular in size and shape. Resting on this fire feature, two large vessels were found, broken <i>in situ</i> .
B-7	2.4 x 0.9	Storage room or magazine in which a set of pottery vessels (including part of a “torpedo” type amphora) were found <i>in situ</i> . Its floor, L0084 , was level with floor L0017, so that it is not a cellar.

A sketch of the stratigraphic history of Building B

1. The walls of Building B were erected, without foundation trenches, on L0289, a laminated layer formed by washed out destruction debris.
2. **External walls** are **L0237** (N), **L0179** (E), **L0014 = L0059 = L0081** (S), **L0015 = L0023** (W).
3. The lower course of walls L0239 and L0209 consists of oblique mud bricks, as is the case in the eastern part of wall L0237 (the western part was destroyed by a deep trench which was found filled by L0001). Also, a few mud bricks of the lower course of Wall L0014 were set obliquely. This practice was apparently intended to compensate for depressions in the layer supporting the building.
4. Mud bricks in Wall L0179 are 40 x 20 x 10 cm in average. The hearth/oven L0176 was built as part of wall L0179.
5. L0014 (= L0059 = L0081). A few mud bricks of the first course were disposed obliquely. The size of the mud bricks up to the 4th course, belonging to the first phase of building of this wall (see below), is quite variable: 40 x 21 x 10 cm, 26 x 19 x 9 cm, 20 x 10 x 8 cm, etc. The two overlying courses correspond to the phase of refurbishing and its mud bricks are quite irregular (some of them looking like *tauf*). An example: 47

- x 20 x 12 cm.
6. The first course of Walls L0012, L0014 and L0015 (= L0023) is a basement consisting of headers, which means that the wall is thicker here than in the following course, built with stretchers (at least, four stretchers and no header could be recognized). Mud bricks are made of sandy clay.
 7. **Internal walls** are L0239, L0323, L0286, L0086, **L0012** (=L0209), L0281. Some notes follow.
 8. The first course of L0012 is composed of oblique mud bricks. Hearth/oven L0013 rests on this wall.
 9. The first course of L0281 consists of headers. The following course is made out of stretchers and headers disposed in no special fashion.
 10. After the construction of the walls, the **floor** was prepared (**L0294**). First, a clayey layer (*tina*) with some inclusions of sand, about 13 cm thick, was placed. This clay was made of the same material as many mud bricks. It was covered with clean sand, of which only some lenses remained.
 11. The *tina* which prepared the floor was also preserved at the exterior of the building, adjacent to southern wall L0014 and stretching for about 1 m. It was identified as **L0016** (= **L0183**).
 12. Human frequentation formed the floors of the first phase of utilization.
 13. A second phase of use followed, separated from the first by an interval of refurbishing, as hinted by the following observations:
 - 13.1. Hearth L0208 (sampled for ¹⁴C) was found intercalated among the mud bricks of the northwestern external wall. Obviously, it was kindled when the wall was in part collapsed and before its reconstruction.
 - 13.2. There is a difference in the kind of mud bricks, noted in L0023 above aforementioned hearth L0208 and in wall L0281, covered by **L0047** y L0086.
 - 13.3. There is a superposition of floors in Room B4, the later one truncating the earlier.
 14. In Room B-5, a simple hearth was kindled directly on the floor.
 15. In this same room, pit L0127 was dug. Its fill was stratified and comprised a ring of carbonaceous sediment, which suggests that it may have served as a receptacle for a hearth. Nevertheless, in its last phase it was not a fire feature, but the place where two pottery vessels rested. They were kept in position by means of several unburned stones (one of them a bad rounded, greenish cobble which must have been brought from a considerable distance, since there are not such things in the Delta). It is possible that pit L0127 had been dug when Building B was already deserted, because: a) the extracted soil was still *in situ*, beside the pit, which would not have happened provided the room was inhabited; b) since the extracted soil was accumulated to the SE of the pit, it seems that it was dug from the N or NW, which is the direction of the prevailing winds. It would have been a wise decision if the decayed building no longer provided a good shelter against the wind.
 16. L0127 and **L0069** were disturbed by intruders between our 1995 and 1996 seasons. Perhaps they looked as a promising tomb.
 17. **Abandon and decay**, as indicated by fallen mud bricks. In Square BB/42, the bricks lay directly over the floor.
 18. When found, the walls of Building B were only one to four courses high, that is, about 23 – 25 high in average. Wall L0179 preserved five courses and was 40 cm high.

2.- Archaeological material

L0012 = L0209 (Fig. 14)

Finds

Personal object

No. 1: beads (2) (Fig. 14), Inv. No. F0039A (Drawing No. 0460). Complete; faience; moulded. 1) 0.80 x 0.60-0.50 cm; 2) 0.80 x 0.60 cm. Colour: 10YR 8/1 (white); cylindrical shape; remains of blue colour on the edges. *Find No. 009.*

L0014 = L0059 = L0081 (Fig. 15)

Pottery

a) Egyptian pottery

Nile silt clay

Household ware

No. 1: juglet (Fig. 15), Inv. No. P0058A (Drawing No. 0158)

RS	Nile E ₂	W ₂	W	ox.	2
----	---------------------	----------------	---	-----	---

Base and body fragment; round base, flattened. Md: 7.00 + x cm; Wd: 0.50 cm; H₁: 3.80 + x cm. Surface colour: 10R 5/8 red slip. Break: 5YR 6/8 reddish yellow. Technical details: throwing lines inside and outside. Surface treatment: smoothed on the wheel.

No. 2: jar (Fig. 15), Inv. No. C-0212 [001]

Uncoated	Nile B ₂	W ₂
----------	---------------------	----------------

Rim sherd; everted direct rim. Rd: 9.00 cm 3/32; Wd: 0.50 cm; H₁: 2.67 + x cm. Throwing lines inside, smoothed on the wheel.

Body sherds, Nile B₂: 1.00 dm²; Nile C₁: 0.25 dm².

b) Imported pottery

Levantine household ware

No. 3: amphora, IV.TG 07, body sherds: 0.10 dm².

Cypriote household ware

No. 4: amphora, VI.TG 04, body sherds: 0.05 dm².

L0015 = L0023 (Fig. 16)

I.- Pottery

a) Egyptian pottery

Nile silt clay

Household ware

No. 1: jar (Fig. 16), Inv. No. P0080A (Drawing No. 0252)

RS	Nile B ₂	W ₂ + Ha ₂	---	ox.	2
----	---------------------	----------------------------------	-----	-----	---

Rim, body fragment and swelling of the handle; everted direct rim. Rd: 14.00 cm 7/32; Md: 22.60 cm; Wd: 0.70 cm; H₁: 10.80 + x cm; Hd: 1.10 x 1.30 cm; 1 [+1]; single strap. Surface colour: 10R 5/8 red slip. Break: 10R 6/4 pale red core; 10R 6/6 light red oxidation zones. Surface treatment: smoothed on the wheel. Smoked.

No. 2: jar (Fig. 16), Inv. No. P0081A (Drawing No. 0225)

RS	Nile B ₂	W ₂	---	ox.	2
----	---------------------	----------------	-----	-----	---

Rim and shoulder fragment; everted direct rim. Rd: 8.00 cm 1/4; Wd: 0.50 cm; H₁: 4.00 + x cm; H₃: 2.60 cm. Surface colour: 10R 5/6 red slip. Break: 2.5YR 5/6 red. Technical details: slightly trimmed rim; a groove on the neck. Surface treatment: smoothed on the wheel.

No. 3: storage jar (Fig. 16), Inv. No. P0383A (Drawing No. 0187)

Uncoated	Nile B ₂	W ₂	---	ox.	2
----------	---------------------	----------------	-----	-----	---

Rim, body fragment and swelling of the handles; inverted modelled rim. Md: 28.00 cm; Wd: 1.50 cm; H₁: 33.00 + x cm. Surface colour: 2.5YR 4/4 dusky red. Break: 5YR 4/1 dark grey core; 5YR 6/6 reddish yellow oxidation zones. Technical details: throwing lines inside; a groove on the rim. Surface treatment: smoothed on the wheel.

Egyptian marls

Household ware

No. 4: jar (Fig. 16), Inv. No. P0085A (Drawing No. 0229)

P	Marl F + limestone	W ₂	---	ox.	3
---	--------------------	----------------	-----	-----	---

Body fragment; biconical type. Md: ca. 12.20 cm; Wd: 0.50 cm; H₁: 6.00 + x cm. Surface colour: 7.5YR 6/3 light brown (self slip). Break: 7.5YR 5/1 grey core; 7.5YR 6/3 light brown oxidation zones. Surface treatment: polished, low lustre.

Body sherds. Nile B₂, Marl F.

L0016 = L0183 (Fig. 17)

I.- Pottery

a) Egyptian pottery

Nile silt clay

Egyptian fine ware

No. 1: jug (Fig. 17:1), Inv. No. P0388A

RP	Nile clay	Ha ₂	---	ox.	3
----	-----------	-----------------	-----	-----	---

Handle fragment; single strap. Hd: 1.75 x 0.85 cm. Surface colour: 2.5YR 6/6 red slip. Break: 2.5YR 4/1 dark reddish grey core; 2.5YR 5/6 red oxidation zones. Surface treatment: polished.

Household ware

No. 2: bowl (Fig. 17:1), Inv. No. C-0038 [001]

Uncoated	Nile B ₂	W ₂
----------	---------------------	----------------

Rim sherd; carinated bowl, slightly inverted direct rim. Rd: 20.00 cm 1/16; smoothed on the wheel.

No. 3: bowl (Fig. 17:1), Inv. No. C-0394 [008]

Uncoated	Nile B ₂	W ₂
----------	---------------------	----------------

Rim sherd; inverted articulated exterior rim. Rd: 10.00 cm 3/32; Wd: 0.40 cm; H₁: 2.22 + x cm. Throwing lines inside; smoothed on the wheel.

No. 4: bowl (Fig. 17:1), Inv. No. C-0394 [009]

Uncoated	Nile B ₂	W ₂
----------	---------------------	----------------

Rim sherd; everted rim. Rd: 28.00 cm 1/16; Wd: 0.67 cm; H₁: 2.00 + x cm; smoothed on the wheel.

No. 5: bowl (Fig. 17:1), Inv. No. C-0394 [003]Uncoated Nile B₂ W₂Rim sherd; everted direct rim, flattened. Rd: 30.00 cm 3/32; Wd: 1.00 cm; H₁: 4.15 + x cm; smoothed on the wheel.**No. 6: bowl (Fig. 17:1), Inv. No. C-0394 [004]**Uncoated Nile B₂ W₂Rim sherd; everted direct rim, flattened. Rd: 30.00 cm 1/16; Wd: 1.00 cm; H₁: 4.90 + x cm; smoothed on the wheel.**No. 7: bowl (Fig. 17:1), Inv. No. C-0394 [013]**Uncoated Nile B₂ W₂Rim sherd; everted direct rim. Rd: 22.00 cm 1/16; Wd: 0.57 cm; H₁: 2.65 + x cm. Throwing lines inside; smoothed on the wheel. Others, Rd: 14.00 cm 1/16, Rd: 20.00 cm 1/16, Rd: 22.00 cm 1/8, Rd: 24.00 cm 1/32, Rd: 26.00 cm 3/16, Rd: 28.00 cm 1/8, Rd: 30.00 cm 7/32, Rd: 34.00 cm 1/16, Rd: 42.00 cm 1/32.**No. 8: bowl (Fig. 17:1), Inv. No. C-0512 (2) [004]**Uncoated Nile B₂ W₂Rim and wall fragment; undulated wall; everted direct rim, round lip. Rd: + 44.00 cm 1/16; Wd: 1.00 cm; H₁: 6.00 + x cm. Eroded.**No. 9: shallow bowl (Fig. 17:1), Inv. No. C-0512 (2) [005]**Uncoated Nile B₂ W₂Rim and wall fragment; incurved wall; inverted direct rim, modelled lip. Rd: 18.00 cm 3/32; Wd: 0.70 cm; H₁: 5.00 + x cm. Throwing lines inside; eroded.**No. 10: cooking pot? (Fig. 17:1), Inv. No. P1205A (Drawing No. 0922)**Uncoated Nile B₂ W₂ --- ox. 2Body fragment; globular type. Md: 32.00 cm; Wd: 1.0 cm; H₁: 13.50 + x cm. Surface colour: 5YR 5/4 reddish brown. Break: 2.5YR 5/1 reddish grey core; 5/6 red oxidation zones. Made in parts; throwing lines inside; three grooves on the shoulder. Surface treatment: smoothed on the wheel. Smoked on the lower part. *Find No. 015.***No. 11: juglet (Fig. 17:2), Inv. No. C-0512 (2) [009]**Uncoated Nile B₂ W₂Neck fragment. Nd: 2.50 cm; Wd: 0.60 cm; H₁: 3.20 + x cm. Throwing lines inside; smoothed on the wheel.**No. 12: jug, Inv. No. C-0475 [001]**Uncoated Nile B₂ Ha₂

Handle fragment; vertical, single strap. Hd: 2.70 x 1.70 cm; smoothed. Another, Hd: 2.70 x 2.56 cm.

No. 13: jar (Fig. 17:2), Inv. No. C-0035 [006]Uncoated Nile B₂ W₂Rim sherd; inverted direct rim. Rd: 11.00 cm 3/32; Wd: 0.65 cm; H₁: 3.50 + x cm; smoothed on the wheel. Others, Rd: 11.00 cm 3/32, Rd: 12.00 cm 1/16.**No. 14: jar (Fig. 17:2), Inv. No. C-0394 [007]**Uncoated Nile B₂ W₂

Rim sherd, vertical direct rim; Rd: 12.00 cm 1/16; Wd: 0.70 cm; H₁: 2.40 + x cm. Throwing lines inside; smoothed on the wheel. Others, Rd: 8.00 cm 3/32, Rd: 10.00 cm 1/8.

No. 15: jar (Fig. 17:2), Inv. No. C-0035 [008]

Uncoated	Nile B ₂	W ₂
----------	---------------------	----------------

Rim sherd; everted direct rim. Rd: 10.00 cm 3/32; Wd: 0.50 cm; H₁: 1.70 + x cm; smoothed on the wheel. Another: Rd: 10.00 cm 3/32.

No. 16: jar, Inv. No. C-0394 [023]

Uncoated	Nile B ₂	W ₂	base finished on the wheel
----------	---------------------	----------------	----------------------------

Base fragment (7/32); ring base. Bd: 11.00 cm; Wd: 0.85 cm; H₁: 3.50 + x cm; smoothed on the wheel.

No. 17: jar, Inv. No. C-0394 [027]

Uncoated	Nile B ₂	Ha ₁ + W ₂
----------	---------------------	----------------------------------

Handle and wall fragment; loop handle. Wd: 1.60 cm; Hd: 4.70 x 3.00 cm, oval in section; 1; 1 strap; H₁: 8.10 + x cm.

No. 18: storage jar (Fig. 17:2), Inv. No. C-0512 (2) [002]

Uncoated	Nile B ₂	W ₂
----------	---------------------	----------------

Rim fragment; inverted symmetrical rim, folded lip. Rd: 22.00 cm 3/32; Wd: 1.10 cm; H₁: 8.20 + x cm. Technical details: throwing lines inside; eroded.

No. 19: storage jar (Fig. 17:2), Inv. No. C-0512 (2) [008]

Uncoated	Nile B ₂	W ₂
----------	---------------------	----------------

Rim fragment; inverted articulated interior, round lip. Rd: 32.00 cm 1/16; Wd: 0.90 cm; H₁: 4.50 + x cm. Throwing lines inside; eroded.

No. 20: storage jar, Inv. No. C-0035 [011]

Uncoated	Nile C ₂	W ₂	W
----------	---------------------	----------------	---

Base fragment, round base. Wd: 1.40 cm; H₁: 3.50 + x cm; smoothed on the wheel. Others, Nile C₁, 2 bases.

Pottery with special functions

No. 21: bakery tray (Fig. 17:2), Inv. No. P0572A (Drawing No. 0238)

Uncoated	Nile B ₂	W ₁	Ha	ox.	2
----------	---------------------	----------------	----	-----	---

Complete, fragmentary; everted direct rim. Rd: 14.00 cm 7/32; Bd: 10.00 cm 1/4; Wd: 0.90 cm; H₁: 2.90 cm. VI: 486. Surface colour: 10R 6/4 pale red. Break: 10R 4/6 red. Surface treatment: smoothed. Eroded rim, smoked areas outside.

No. 22: bakery tray (Fig. 17:2), Inv. No. P0589A (Drawing No. 0244)

Uncoated	Nile C ₂	W ₁	Ha	ox.	2
----------	---------------------	----------------	----	-----	---

Complete, fragmentary; everted direct rim. Rd: 18.00 cm 1/8; Bd: 16.00 cm 1/8; Wd: 0.80 cm; H₁: 4.50 cm. VI: 400. Surface colour: 7.5YR 7/3 pink. Break: 2.5YR 5/8 red. Eroded base; fingerprints on the base. Surface treatment: uneven. Another, Nile C₁, Rd: 22.00 cm 3/16.

No. 23: lid (Fig. 17:3), Inv. No. C-0512 (2) [006]

Uncoated	Nile C ₁	W ₂
----------	---------------------	----------------

Rim fragment; everted, articulated exterior, round lip. Rd: 22.00 cm 3/32; Wd: 1.00 cm;

H₁: 4.00 + x cm. Throwing lines inside; eroded and smoked.

No. 24: tray, Inv. No. C-0035 [003]

Uncoated Nile C₂ Ha₁

Fragment. D: 20.00 cm 1/16; Wd: 1.50 cm; smoothed. Others, D: 20 cm 1/16; body fragments.

Votive or model pottery

No. 25: model bowl, Inv. No. P0762A

Uncoated Nile B₂ W₁ W ox. 2

Complete, fragmentary, flat base. Rd: 6.00 cm 3/16; Bd: 5.00 cm 1/4; Wd: 0.70 cm; H₁: 1.50 cm. VI: 400. Surface colour: 2.5YR 6/4 light reddish brown. Break: 2.5YR 6/4 light reddish brown. Surface treatment: smoothed on the wheel.

No. 26: model amphora (Fig. 17:3), Inv. No. P0625 (Drawing No. 0255)

Uncoated Nile B₂ W₁ W ox. 2

Complete; pointed base; two handles Rd: 3.20 cm; Nd: 3.40 cm; Md: 6.30 cm; H₁: 8.80 cm; H₂: 6.80 cm; H₃: 0.70 cm; Hd: 0.80 x 0.50 cm. VI: 72. Surface colour: 10R 5/6 red. Break: ---. Technical details: handles placed on the shoulder at different distance between them. Surface treatment: smoothed on the wheel. SCA. *Find No. 014.*

Egyptian marls

Household ware

No. 27: amphora, Inv. No. C-0038 [002]

Uncoated Marl A₄ Ha₂

Handle fragment. Hd: 2.80 x 1.20 cm; smoothed.

No. 28: amphora (Fig. 17:3), Inv. No. C-0394 [012]

Uncoated Marl F + ochre W₂

Rim sherd; inverted direct rim. Rd: 12.00 cm 3/32; Wd: 0.63 cm; H₁: 2.53 + x cm. Throwing lines inside; smoothed on the wheel.

Body sherds, Nile B₂: 21.50 dm²; Nile C₁: 0.45 dm²; Nile E₁: 0.75 dm². Marl A₄; Marl F.

b) North Sinai/South Palestine pottery

Household ware

No. 29: amphora, II.TG 08, body sherds: 0.10 dm².

No. 30: amphora, II.TG 10, body sherds: 0.60 dm².

No. 31: amphora, II.TG 59, body sherds: 0.10 dm².

c) Imported pottery

Phoenician fine ware

Black-on-Red

No. 32: juglet (Fig. 17:3), Inv. No. P0040A (Drawing No. 0237)

BP[MO] IV.TG 37 = IV.Phoen?.03 W₂ W ox. 3

Base 1/4 and a fragment of the wall; flat base. Md: 3.00 + x cm; Bd: 2.90 cm; Wd: 0.30 cm; H₁: 3.50 + x cm; H₂: 2.50 cm. Surface colour: 10YR 6/4 light yellowish brown slip. Break: 10YR 4/1 dark grey core; 6/4 light yellowish brown oxidation zones. Decoration: no decoration in the fragment preserved. Surface treatment: polished, medium lustre.

Levantine household ware**No. 33: bowl** (Fig. 17:3), Inv. No. C-0035 (2) [001]Uncoated | IV.TG 05 | W₂Rim and wall fragment; everted. Rd: 28.00 cm 3/32; Wd: 0.60 cm; H₁: 4.00 + x cm; throwing lines inside; smoothed on the wheel.**No. 34: jug** (Fig. 17:3), Inv. No. P0859A (Drawing No. 0464)Uncoated | IV.TG 18 | Ha₂+W₂ | --- | ox. | 3Rim and handle fragment; inverted direct rim; loop handle. Rd: 18.00 cm 1/18; Wd: 1.20 cm; Hd: 2.50 x 1.50 cm, single strap; H₁: 2.90 + x cm. Surface colour: 5YR 6/4 light reddish brown. Break: 5YR 6/4 light reddish brown. Technical details: throwing lines inside. Surface treatment: smoothed. Smoked in some parts.**No. 35: amphora**, IV, TG 01, body sherds: 0.40 dm².**No. 36: amphora**, IV.TG 03, body sherds: 0.80 dm².**No. 37: amphora**, IV.TG 05, body sherds: 0.10 dm².**No. 38: amphora**, IV.TG 07, body sherds: 0.50 dm².**No. 39: amphora** (Fig. 17:3), Inv. No. C-0395 [013]Coated | IV.TG 11 | W₂Rim sherd; inverted articulated exterior rim. Rd: 10.00 cm 3/16; Wd: 0.45 cm; H₁: 2.35 + x cm; throwing lines inside; smoothed on the wheel.**No. 40: amphora**, IV.TG 11, body sherds: 0.40 dm².**No. 41: amphora**, IV.TG 16, body sherds: 0.10 dm².**No. 42: amphora**, Inv. No. C-0512 (2) [012]Uncoated | IV.TG 17 | Ha₂ | --- | ox. | 3

Handle fragment; single strap. Hd: 2.80 x 1.90 cm; smoothed.

No. 43: amphora (Fig. 17:4), Inv. No. P1283A (Drawing No. 0708)Uncoated | IV.TG 18 | Ha₂ | --- | ox. | 3

Handle fragment; single strap. Hd: 3.00 x 1.80 cm. Surface colour: 7.5YR 7/4 pink. Break: 10YR 5/2 greyish brown. Surface treatment: smoothed.

No. 44: amphora, IV.TG 18, body sherds: 0.10 dm².**No. 45: amphora**, IV.TG 23, body sherds: 0.40 dm².**No. 46: amphora**, similar to IV.TG 23, body sherds: 0.10 dm².**No. 47: amphora**, IV.TG 24, body sherds: 0.10 dm².**No. 48: amphora**, IV.TG 51 (= TD IV.19), body sherds: 0.30 dm².**No. 49: amphora**, IV.TG 52? (= TD IV.19 c.), body sherds: 0.20 dm².**No. 50: amphora**, IV.TG 53 (= TD IV.09), body sherds: 0.40 dm².**No. 51: amphora**, = TD IV.08, body sherds: 0.10 dm².**No. 52: amphora**, = TD IV.08 c., body sherds: 0.10 dm².**Cypriote pottery****Fine ware***White Painted ware***No. 53: jar ?** (Fig. 17:4), Inv. No. P0521A (Drawing No. 0226)WPMO | VI.TG 04 | W₂ | --- | ox. | 3Body sherd. Md: 16.00 + x cm; Wd: 0.55 cm; H₁: 3.32 + x cm. Surface colour: 7.5YR 8/2

pinkish white slip. Break: 7.5YR 6/6 light brown. Decoration: two horizontally painted lines, 3 mm and 2 mm wide, 7.5YR 6/6 brown. Surface treatment: polished, low lustre.

Cypriote household ware

No. 54: amphora, VI.TG 04, body sherds: 0.30 dm².

No. 55: amphora, VI.TG 40, body sherds: 0.10 dm².

No. 56: amphora, VI.TG 43, body sherds: 0.30 dm².

No. 57: amphora, VI.TG 44, body sherds: 0.10 dm².

Aegean fine ware

Black-on-Red II (IV)

No. 58: juglet (Fig. 17:4), Inv. No. P0045A (Drawing No. 0231)

PPMO	VII.TG 45	Ha ₂	---	ox.	3
------	-----------	-----------------	-----	-----	---

Handle fragment; oval in section, 1; single strap. Hd: 0.75 x 0.55 cm. Surface colour: 2.5YR 6/8 red slip. Break: 2.5YR 6/8 reddish yellow. Decoration: horizontally painted bands, framed by a vertically band, 2 mm wide, 2.5YR 4/4 dusky red. Surface treatment: polished, low lustre.

Aegean household ware

No. 59: juglet, Inv. No. C-0512 (2) [001]

P	VII.TG 39	W ₂	---	ox.	3
---	-----------	----------------	-----	-----	---

Rim sherd. Rd: 4.00 cm 3/32; Wd: 0.20 cm; H1: 1.00 + x cm; eroded.

No. 60: amphora, VII.TG 39, body sherds: 0.10 dm².

II.- Finds

Personal objects

No. 61: bead (Plate 5), Inv. No. F0205 (Drawing No. 0116. F29). Complete; limestone. 1.00 x 1.10 cm; barrel shape; perforation: 1 mm. SCA No. 1013. *Find No. 011.*

No. 62: pendant (Fig. 17:4), Inv. No. F0208A (Drawing No. 0151. F27). Complete; shell (*Ciprea albina*). 2.20 x 1.50-0.80 x 0.60-0.40 cm. Function: female fertility amulet. *Find No. 013.*

Recreation

No. 63: gaming piece?, Inv. No. F0284A. Pottery; made from a sherd. 3.00 x 3.20 x 1.70 cm; colour: 2.5YR red and 10R 6/4 pink red.

Objects of unknown use

No. 64: fragment of an object, Inv. No. F0296A. Bronze.

No. 65: fragment of an object (Fig. 17:4), Inv. No. F0298A (Drawing No. 0457). Bronze; melted. 2.20 x 0.50 x 0.30 cm; cylindrical shape. *Find No. 017.*

Tool

No. 66: sharpener, Inv. No. F0409A (Drawing No. 0266). Pumice. 3.20 x 3.60 x 2.60 cm. *Find No. 019.*

Product

No. 67: faience slag, Inv. No. F0204A.

No. 68: faience slag, Inv. No. F0759A.

L0017 (Fig. 18)**I.- Pottery****a) Egyptian pottery****Nile silt clay****Household ware****No. 1: bowl (Fig. 18:1), Inv. No. C-0044 [033]**

Uncoated	Nile B ₂	W ₂
----------	---------------------	----------------

Rim sherd, inverted direct rim. Rd: 16.00 cm 1/32; Wd: 1.00 cm; H₁: 4.90 + x cm; throwing lines outside; smoothed on the wheel. Others, Rd: 12.00 cm 3/32, Rd: 18.00 cm 5/32.

No. 2: bowl (Fig. 18:1), Inv. No. C-0044 [007]

Uncoated	Nile B ₂	W ₂
----------	---------------------	----------------

Rim sherd, everted direct rim. Rd: 16.00 cm 1/64; Wd: 0.30 cm; H₁: 2.00 + x cm; throwing lines outside; smoothed on the wheel. Others, Rd: 20.00 cm 1/4, Rd: 22.00 cm 1/16, Rd: 22.00 cm 1/8, Rd: 26.00 cm 1/4.

No. 3: bowl (Fig. 18:1), Inv. No. C-0046 [006]

Uncoated	Nile B ₂	W ₂
----------	---------------------	----------------

Rim sherd, everted articulated exterior rim, round lip. Rd: 20.00 cm 1/16; Wd: 0.48 cm; H₁: 2.45 + x cm; throwing lines outside; smoothed on the wheel. Others, Rd: 19.00 cm 1/16, Rd: 20.00 cm 1/16, Rd: 22.00 cm 1/32.

No. 4: bowl (Fig. 18:1), Inv. No. C-0044 [023]

Uncoated	Nile C ₁	W ₂
----------	---------------------	----------------

Rim sherd, everted articulated exterior and interior rim. Rd: 21.00 cm 3/32; Wd: 0.60 cm; H₁: 2.60 + x cm; throwing lines outside; smoothed on the wheel.

No. 5: bowl, Inv. No. C-0044 [003]

Uncoated	Nile C ₁	W ₂
----------	---------------------	----------------

Rim sherd, everted direct trimmed rim. Rd: 24.00 cm 3/32; Wd: 0.67 cm; H₁: 2.25 + x cm; throwing lines outside; smoothed on the wheel; eroded.

No. 6: bowl (Fig. 18:1), Inv. No. C-0036 [003]

Uncoated	Nile B ₂	W ₂
----------	---------------------	----------------

Rim sherd, everted direct rim. Rd: 32.00 cm 3/64; Wd: 0.95 cm; H₁: 3.20 + x cm; throwing lines outside; smoothed on the wheel. Others, Rd: 31.00 cm 1/32. Nile C₂, Rd: 50.00 cm 1/16.

No. 7: bowl (Fig. 18:1), Inv. No. C-0044 [001]

Uncoated	Nile B ₂	W ₂
----------	---------------------	----------------

Rim sherd, everted articulated exterior rim. Rd: 40.00 cm 1/16 Wd: 0.80-1.10 cm; H₁: 5.00 + x cm; smoothed on the wheel. Another, Rd: 32.00 cm 1/32.

No. 8: carinated bowl (Fig. 18:1), Inv. No. P0120A (Drawing No.0933)

Uncoated	Nile B ₂	W ₁	---	ox.	2
----------	---------------------	----------------	-----	-----	---

Rim and body sherd; everted direct rim. Rd: ca.10.00 cm 1/32; Wd: 0.40 cm; H₁: 3.60 + x cm. Surface colour: 5YR 6/3 light reddish brown. Break: 2.5YR 6/6 red. Technical details: throwing lines outside and inside. Surface treatment: wheel smoothed.

No. 9: deep bowl (Fig. 18:1), Inv. No. C-0042 [001]

Uncoated	Nile E ₂	W ₂
----------	---------------------	----------------

Rim sherd, vertical direct rim. Rd: 14.00 cm 1/8; Wd: 0.55 cm; H₁: 5.50 + x cm; throwing lines outside; smoothed on the wheel.

No. 10: cup (Fig. 18:1), Inv. No. C-0044 [031]

Uncoated	Nile B ₂	W ₂
----------	---------------------	----------------

Rim sherd, slightly inverted direct rim. Rd: 9.00 cm 1/16; Wd: 0.30 cm; H₁: 1.56 + x cm; throwing lines outside; smoothed on the wheel.

No. 11: cup (Fig. 18:1), Inv. No. C-0044 [032]

Uncoated	Nile B ₂	W ₂
----------	---------------------	----------------

Rim sherd, vertical direct rim. Rd: 9.00 cm 1/16; Wd: 0.30 cm; H₁: 1.60 + x cm; throwing lines outside; smoothed on the wheel.

No. 12: cup, Inv. No. P0118A

Uncoated	Nile B ₂	W ₂	---	ox.	2
----------	---------------------	----------------	-----	-----	---

Base and body fragment; pointed base. Wd: 1.08-1.24 cm; H₁: 8.10 + x cm. Surface colour: 2.5YR 5/4 weak red. Break: 2.5YR 6/6 red. Surface treatment: wheel smoothed.

No. 13: pot (Fig. 18:2), Inv. No. P0052 (before Inv. No. P0050. Drawing No. 0052. F12)

Uncoated	Nile B ₂	W ₁	base finished on the wheel	ox.	2
----------	---------------------	----------------	----------------------------	-----	---

Complete; pointed base; slightly inverted direct rim. Rd: 3.00 cm; Md: 6.20 cm; Wd: 0.67 cm; H₁: 7.50 cm; H₂: 3.96 cm; H₃: 1.45 cm. VI: 83. Surface colour: 7.5YR 6/3 light brown. Break: ---. Technical details: made in two parts and joined below the major point. Surface treatment: smoothed on the wheel. SCA.

No. 14: pot (Fig. 18:2), Inv. No. C-0044 [030]

Uncoated	Nile B ₂	W ₂
----------	---------------------	----------------

Rim sherd, vertical direct rim. Rd: 4.00 cm 1/8; Wd: 0.30 cm; H₁: 1.30 + x cm; throwing lines inside; smoothed on the wheel.

No. 15: jar (Fig. 18:2), Inv. No. C-0046 [001]

Uncoated	Nile E ₂	W ₂
----------	---------------------	----------------

Rim sherd, slightly everted direct rim. Rd: 12.00 cm 5/32; Wd: 0.60 cm; H₁: 4.80 + x cm; throwing lines inside; smoothed on the wheel.

No. 16: jar (Fig. 18:2), Inv. No. C-0044 [027]

Uncoated	Nile B ₂	W ₂
----------	---------------------	----------------

Rim sherd, vertical direct rim. Rd: 10.00 cm 3/32; Wd: 0.60 cm; H₁: 5.00 + x cm; throwing lines inside; smoothed on the wheel. Another, Nile E₁, Rd: 11.00 cm 3/16.

No. 17: jar (Fig. 18:2), Inv. No. P0122A (Drawing No. 0185)

Uncoated	Nile E ₂	W ₂	W	ox.	2
----------	---------------------	----------------	---	-----	---

Base fragment, round. Md: 8.00 + cm; Wd: 0.50 cm; H₁: 3.40 + x cm. Surface colour: 2.5YR 6/8 red. Break: 2.5YR 6/8 red. Technical details: throwing lines inside. Surface treatment: smoothed on the wheel. Others, Nile B₂, 1 base; Nile C₁, 1 base.

No. 18: jar, Inv. No. C-0046 [004]

Uncoated	Nile E ₂	W ₂	W
----------	---------------------	----------------	---

Base fragment, nipple base; Md: 4.50 + x cm; Wd: 0.60 cm; H₁: 1.50 + x cm; throwing lines inside; smoothed on the wheel.

Pottery with special function**No. 19: bakery tray**, Inv. No. P0117A (Drawing No. 0208)

Uncoated	Nile E ₂	W ₁	Ha	ox.	2
----------	---------------------	----------------	----	-----	---

Complete, fragmentary; flat base, 1/8 preserved; everted direct rim. Rd: 20.00 cm; Bd: 16.00 cm; Wd: 1.70 cm; H₁: 3.80 cm. VI: 526. Surface colour: 5YR 6/6 reddish yellow. Break: 2.5YR 5/8 red. Surface treatment: smoothed. Another (only rim), Nile C₂, Rd: 26.00 cm 1/16.

Votive or model pottery**No. 20: model bowl** (Fig. 18:2), Inv. No. C-0046 (2) [002]

Uncoated	Nile B ₂	W ₂			
----------	---------------------	----------------	--	--	--

Rim sherd; carinated bowl (reconstructed shape); inverted direct rim, round lip. Rd: 4.00 cm 3/32; Wd: 0.35 cm; H₁: 1.30 + x cm. Throwing lines inside; smoothed on the wheel.

Egyptian marls**Household ware****No. 21: jar** (Fig. 18:2), Inv. No. P0051A (Drawing No. 0080)

P	Marl A ₄ c.	W ₂	---	ox.	3
---	------------------------	----------------	-----	-----	---

Neck and rim fragment; everted rim. Rd: 6.00 cm; Nd: 3.30-4.80 cm; Wd: 0.35 cm; H₃: 5.00 cm. Surface colour: 10YR 7/3 very pale brown; 5Y 7/2 light grey self-slip. Break: 10YR 7/3 very pale brown. Technical details: very fine ridges on the interior. Surface treatment: polished, low lustre.

Body sherds, Nile B₂: 45.00 dm²; Nile C₁: 0.60 dm²; Nile C₂: 12.00 dm²; Nile E₁: 0.80 dm²; Nile E₂: 5.00 dm²; Marl A₄: 0.10 dm²; Marl F: 0.35 dm²; Marl F s.: 0.10 dm²; Marl F v.s.: 0.10 dm².

b) North Sinai/South Palestine pottery**Household ware****No. 22: jar**, Inv. No. P0123A (Drawing No. 0065. F14)

Uncoated	II.TG 08	W ₂	W	ox.	2-3
----------	----------	----------------	---	-----	-----

Base (flat) and wall fragment; 1/4 preserved. Bd: 3.00 cm 1/4; Wd: 0.35 cm; H₁: 4.50 + x cm; H₂: 3.80 + x cm. Surface colour: 5Y 7/3 pale yellow. Break: 5Y 7/3 pale yellow. Technical details: throwing lines on the interior and exterior; shallow grooves inside. Surface treatment: smoothed on the wheel.

No. 23: amphora, II.TG 08, body sherds: 0.45 dm².**No. 24: amphora**, II.TG 10, body sherds: 0.10 dm².**c) Imported pottery****Levantine fine ware****Black-on-Red ware****No. 25: jug** (Fig. 18:3), Inv. No. P1193A (Drawing No. 0702)

WPMO	IV.TG 57 (= TD IV.12)	W ₂	---	ox.	3
------	-----------------------	----------------	-----	-----	---

Body sherds (2). Md: 15.50 cm; Wd: 0.45 cm; H₁: 3.60 + x cm. Surface colour: 5YR 6/6 reddish yellow slip. Break: 5YR 5/6 yellowish red. Surface treatment: polished, medium lustre.

No. 26: jug or jar? (Fig. 18:3), Inv. No. P0093A₁₋₂ (Drawing No. 0055. F13)

WPMO	IV.TG 51 (= TD IV.19)	W ₂	---	ox.	3
------	-----------------------	----------------	-----	-----	---

Body sherds (3); 2 fragments from the shoulder. Md: 16.40 + x cm; Wd: 0.38 cm; H₁: 4.00

+ x cm and 1.60 + x cm. Surface colour: 5YR 7/6 reddish yellow slip. Break: 5YR 6/6 reddish yellow. Technical details: grooves inside. Decoration: painted lines, straight and concentric, 5YR 2.5/2 dark reddish brown. Surface decoration: polished, low lustre.

Levantine household ware

- No. 27: amphora**, IV.TG 01, body sherd: 1.25 dm².
No. 28: amphora, IV.TG 03, body sherd: 0.80 dm².
No. 29: amphora, IV.TG 06, body sherd: 0.20 dm².
No. 30: amphora, IV.TG 07, body sherd: 0.10 dm².
No. 31: amphora, IV.TG 11, body sherd: 0.60 dm².
No. 32: amphora, IV.TG 18, body sherd: 0.30 dm².
No. 33: amphora, IV.TG.19, body sherds: 0.02 dm².
No. 34: amphora, IV.TG 23, body sherd: 0.20 dm².
No. 35: amphora, IV.TG 24, body sherd: 0.10 dm².
No. 36: amphora, IV.TG 29, body sherd: 0.25 dm².
No. 37: amphora, IV.TG 32, body sherd: 0.20 dm².
No. 38: amphora, IV.TG 13 (= IV.Phoen.05), body sherd: 0.10 dm².
No. 39: amphora, IV.TG 51 (= TD IV.1), body sherd: 0.30 dm².
No. 40: amphora, IV.TG 53 (= TD IV.09), body sherd: 0.30 dm².
No. 41: amphora, IV.TG 57 (= TD IV.12), body sherd: 0.10 dm².
No. 42: amphora, = TD IV.02, body sherd: 0.10 dm².
No. 43: amphora, = TD IV.08, body sherd: 0.10 dm².

Phoenician household ware

- No. 44: amphora**, IV.TG 22 = IV.Phoen?04, body sherd: 0.20 dm².

Cypriote household ware

- No. 45: amphora**, VI.TG 04, body sherds: 0.40 dm².
No. 46: amphora, VI.TG 44, body sherd: 0.10 dm².

Aegean fine ware

- No. 47: juglet (Fig. 18:4), Inv. No. P0119A** (Drawing No. 0076)

RP	VII.TG 39	W ₂	---	ox.	3
----	-----------	----------------	-----	-----	---

Rim and neck fragment; everted rim. Rd: 5.00 cm 7/32; Wd: 0.32 cm; H₁: 2.00 + x cm. Surface colour: 2.5YR 6/6 red slip. Break: 2.5YR 6/6 red. Surface treatment: polished, low lustre.

Black-on-Red II (IV) ware

- No. 48: juglet (Fig. 18:4), Inv. No. P0063A** (Drawing No. 0012. F2)

RPMO	VII.TG 39	W ₂	---	ox.	3
------	-----------	----------------	-----	-----	---

Rim and neck fragment; everted direct rim. Rd: 5.00 cm 1/16; Nd: 2.50 cm; Wd: 0.30 cm; H₃: 2.00 cm. Surface colour: 2.5YR 6/6 red slip. Break: 2.5YR 6/6 red. Technical details: ridges inside. Decoration: horizontally painted lines on the neck and rim, outside and inside, 5YR 2.5/1 black. Surface treatment: polished, low lustre.

- No. 49: juglet (Fig. 18:4), Inv. No. P0060A** (Drawing No. 0002. F1)

RPMO	VII.TG 39	W ₂	---	ox.	3
------	-----------	----------------	-----	-----	---

Body sherd. Md: ca. 6.00 cm; Wd: 0.30 cm; H₁: 2.30 + x cm. Surface colour: 2.5YR 6/6 red slip. Break: 2.5YR 6/6 red. Decoration: 7 horizontally painted lines, 5YR 2.5/1 black. Technical details: ridges inside. Surface treatment: polished, low lustre.

Aegean household ware

No. 50: amphora, VII.TG 39, body sherd: 0.10 dm².

II.- Finds***Religion******Amulet***

No. 51: wdjat Menkheperre (Plates 6 and 7), Inv. No. F1000 (Drawing No. 0924). Fragmentary; faience; moulded. 3.15 x 2.10 x 0.40-0.70 cm; colour: white. Flat on the obverse, with Menkheperre inside the cartouche, five incised lines above it and an incise pattern decoration; horizontal perforation. The lower part is lacking; broken in the middle. SCA.

No. 52: Bes figurine (Plate 8), Inv. No. F0009 (Drawing No. 0025). Complete; faience; moulded. 0.95 x 2.35 x 0.75 cm; colour: 5GY 7/1 light greenish grey. A Bes figurine with the feather crown; the right arm is broken. SCA No. 0982. *Find No. 032*.

Personal object

No. 53: compound bead (Plate 9), Inv. No. F0008 (Drawing No. 0006). Complete; gold; melted. 1.30 cm length x 0.45 cm of diameter. Round shaped beads; it is formed by eight interior rows and eight exterior of round beads; very fine bead. SCA No. 0970 (now in Cairo Museum). *Find No. 028*.

Tool

No. 54: sharpener (Fig. 18:5), Inv. No. F0011A (Drawing No. 0181). Fragmentary; pumiced. 3.00 x 4.20 x 2.20 cm; colour: white 5YR 8/1. Manufacture: sharpener by use. Wear type: friction. Wear marks: incised grooves on the surface.

Suspended weight

No. 55: spindle whorl? (Fig. 18:5), Inv. No. F0010A (Drawing No. 0169). Fragmentary; limestone. 2.30 x 1.10 x 0.90 cm; cylindrical shape. *Find No. 33*.

L0029 (Fig. 19)**Egyptian pottery, marl*****Household ware***

No. 1: deep bowl (Fig. 19), Inv. No. P0068A (Drawing No. 0081. F17)

Uncoated	Marl A ₄	W ₂	---	ox.	3
----------	---------------------	----------------	-----	-----	---

Rim sherd; direct rim. Rd: 10.00 cm 1/8; Wd: 0.20-0.22 cm; H₁: 3.10 + x cm. Surface colour: 2.5YR 6/6 red. Break: 2.5YR 5/6 red. Technical details: very thin walls; very fine throwing lines on the interior. Surface treatment: well smoothed on the wheel. *Find No. 017*.

L0038 (Fig. 20)**I.- Pottery****a) Egyptian pottery****Nile silt clay*****Household ware***

No. 1: bowl (Fig. 20), Inv. No. C-0079 [001]

Uncoated	Nile B ₂	W ₂
----------	---------------------	----------------

Rim sherd; everted direct rim. Rd: 24.00 cm 1/32; Wd: 0.70 cm; H₁: 2.00 + x cm. Throwing lines outside; smoothed on the wheel.

No. 2: jar (Fig. 20), Inv. No. C-0079 [002]Uncoated Nile C₁ W₂Rim sherd; vertical direct rim. Rd: 12.00 cm 5/64; Wd: 0.65 cm; H₁: 2.00 + x cm. Throwing lines inside; smoothed on the wheel.**No. 3: jar (Fig. 20), Inv. No. C-0070 [003]**Uncoated Nile C₁ W₂Rim sherd; slightly everted articulated exterior rim, rounded lip. Rd: 12.00 cm 3/32; Wd: 0.60 cm; H₁: 5.50 + x cm. Throwing lines inside; smoothed on the wheel.**No. 4: jar, Inv. No. C-0070 [004]**Uncoated Nile B₂ W₂ W

Base fragment; round. Wd: 0.80 cm. Throwing lines inside; smoothed on the wheel.

No. 5: storage jar? (Fig. 20), Inv. No. C-0070 (2) [001]Uncoated Nile E₂ W₂Rim sherd; inverted articulated interior and exterior rim, rounded lip. Rd: 30.00 cm 1/16; Wd: 1.60 cm; H₁: 4.20 + x cm. Throwing lines inside; smoothed on the wheel.**No. 6: storage jar (Fig. 20), Inv. No. C-0070 [002]**Uncoated Nile B₂ W₂Rim sherd; vertical articulated exterior rim, modelled lip. Rd: 22.00 cm 5/32; Wd: 0.75 cm; H₁: 2.50 + x cm. Throwing lines inside; smoothed on the wheel; overfired.**Body sherds**, Nile B₂: 3.70 dm²; Nile C₂: 3.00 dm²; Nile E: 2.10 dm²; Marl A₄: 0.10 dm².**b) North Sinai/South Palestine pottery****Household ware****No. 7: amphora**, II.TG 08, body sherds: 0.10 dm².**c) Imported pottery****Levantine fine ware****No. 8: juglet? (Fig. 20), Inv. No. P0524A (Drawing No. 0237)**RP = TD IV.02 W₂ --- ox. 3Neck and body fragment. Nd: 4.00 cm; Md: ca. 8.00 cm; Wd: 0.45 cm; H₁: 2.70 + x cm. Surface colour: 10R 5/6 red slip. Break: 5YR 6/6 reddish yellow. Technical details: throwing lines inside. Surface treatment: burnished; medium lustre. Smoked inside.**Household ware****No. 9: amphora**, IV.TG 03, body sherds: 0.10 dm².**No. 10: amphora**, Inv. C-0070 [005]Uncoated = TD IV.02 Ha₂Handle fragment; Hd: 3.50 x 2.00 cm; smoothed. Body sherds: 0.10 dm².**No. 11: amphora**, = TD IV.08, body sherds: 0.10 dm².**Cypriote fine ware****White Painted II ware****No. 12: bowl (Fig. 20), Inv. No. P0074A (Drawing No. 0075)**WPMO VI.TG 04 W₂ --- ox. 3Body sherd. Md: 7.00 + x cm; Wd: 0.33 cm; H₁: 2.20 + x cm. Surface colour: 7.5YR 8/3

pink slip. Break: 7.5YR 7/6 reddish yellow. Decoration: horizontally painted lines outside and oblique inside, 2 mm wide, 7.5YR 3/2 dark brown. Surface treatment: polished, low lustre. *Find No. 015.*

White Painted IV ware?

No. 13: jug (Fig. 20), Inv. No. P0090A (Drawing No. 0078. F16)

BPMO	VI.TG 04	W ₂	---	ox.	3
------	----------	----------------	-----	-----	---

Rim and neck sherd; oval mouth; everted direct rim. Rd: 6.40 cm; Nd: 5.00 cm; Wd: 0.28 cm; H₃: 2.50 + x cm. Surface colour: 10YR 7/4 very pale brown slip. Break: 10YR 6/4 light yellowish brown. Technical details: throwing lines inside, no handle preserved. Decoration: horizontally painted bands on the rim, 4 mm wide, outside and inside, 10YR 3/2 very dark greyish brown. Surface treatment: polished, low lustre. *Find No. 016.*

Household ware

No. 14: amphora, VI.TG 04, body sherds: 0.10 dm².

II.- Finds

Religion

No. 15: wdjat?, Inv. No. F0138A (Drawing No. 0180). Fragmentary; faience; moulded. 1.00 x 1.20 x 0.40 cm; colour: 5GY 7/1 light greenish grey. Description: central part of the eye?

Personal objects

No. 16: bead (Fig. 20), Inv. No. F0133 (Drawing No. 0180). Complete; shell. 1.40 x 1.20 x 0.90cm. SCA No. 1025. *Find No. 065.*

No. 17: bead (Plate 10), Inv. No. F0137 (Drawing No. 0026. F07). Complete; alabaster ("rokham"). 2.25 x 0.80-0.60 cm; colour: yellow, light brown, white. Barrel-shaped bead; very well smoothed. Eroded. SCA No. 0986. *Find No. 069.*

L0047 (Fig. 21)

I.- Pottery

a) Egyptian pottery

Nile silt clay

Fine ware

No. 1: bowl, Inv. No. C-0429 [003]

RP	Nile B ₂	W ₂	base finished on the wheel		
----	---------------------	----------------	----------------------------	--	--

Base fragment (R₃). Bd: 6.00 cm 1/4; Wd: 0.85 cm. Throwing lines outside; polished.

Household ware

No. 2: bowl (Fig. 21:1), Inv. No. C-0429 (4) [002]

Uncoated	Nile B ₂	W ₂	W	ox.	2
----------	---------------------	----------------	---	-----	---

Nearly complete, fragmentary; rim and wall fragment; everted articulated exterior rim, pendant lip. Rd: 18.00 cm 3/32; Wd: 0.50 cm; H₁: 5.50 cm. VI: 436. Throwing lines outside; smoothed on the wheel.

No. 3: bowl (Fig. 21:1), Inv. No. C-0429 (2) [001]

Uncoated	Nile B ₂	W ₂
----------	---------------------	----------------

Rim sherd; everted direct rim. Rd: 20.00 cm 1/4; Wd: 0.80 cm; H₁: 4.90 + x cm. Throwing lines inside; smoothed on the wheel; eroded. Others, Rd: 18.00 cm 1/16, Rd: 22.00 cm 1/8, Rd: 26.00 cm 1/16, Rd: 31.00 cm 1/16. Nile C₁, Rd: 20.00 cm 5/32.

No. 4: bowl (Fig. 21:1), Inv. No. C-0429 (4) [001]

Uncoated	Nile B ₂	W ₂
----------	---------------------	----------------

Rim sherd (reconstructed shape); everted articulated interior and exterior rim, trimmed lip. Rd: 30.00 cm 5/32; Wd: 0.90 cm; H₁: 4.90 + x cm. Throwing lines inside; smoothed on the wheel.

No. 5: large bowl (Fig. 21:1), Inv. No. P1013A (Drawing No. 0366)

Uncoated	Nile C ₁	W ₂ + Ha ₂	---	ox.	2
----------	---------------------	----------------------------------	-----	-----	---

Rim sherd, 1/16. Rd: 44.0 cm; Wd: 0.8 cm; H₁: 5.85 + x cm. Surface colour: 2.5YR 6/6 light red. Break: 10R 4/6 red core; 2.5YR 6/8 light red oxidation zones. Technical details: throwing lines outside. Decoration: applied decoration on the rim, made with a knob of clay. Surface treatment: smoothed. Eroded.

No. 6: bowl (Fig. 21:1), Inv. No. C-0429 (2) [003]

Uncoated	Nile C ₁	W ₂
----------	---------------------	----------------

Rim sherd; inverted direct rim, round lip. Rd: 20.00 cm 1/4; Wd: 0.80 cm; H₁: 6.90 + x cm. Throwing lines inside; smoothed on the wheel; eroded.

No. 7: pot (Fig. 21:1), Inv. No. C-0429 (2) [005]

Uncoated	Nile C ₁	W ₂
----------	---------------------	----------------

Rim sherd; inverted direct rim, round lip. Rd: 4.00 cm 1/4; Wd: 0.30 cm; H₁: 1.50 + x cm. Throwing lines inside; smoothed on the wheel; eroded.

No. 8: jar (Fig. 21:1), Inv. No. C-0429 (4) [009]

Uncoated	Nile B ₂	W ₂
----------	---------------------	----------------

Rim sherd; inverted direct rim. Rd: 9.50 cm 1/32; Wd: 0.70 cm; H₁: 3.10 + x cm. Throwing lines inside; smoothed on the wheel.

No. 9: jar (Fig. 21:1), Inv. No. C-0429 (4) [008]

Uncoated	Nile B ₂	W ₂
----------	---------------------	----------------

Rim fragment; inverted articulated exterior rim, flattened lip. Rd: 12.00 cm 1/8; Wd: 0.80 cm; H₁: 4.80 + x cm. Throwing lines inside; smoothed on the wheel.

No. 10: jar (Fig. 21:2), Inv. No. C-0429 (3) [001]

Uncoated	Nile B ₂	W ₂
----------	---------------------	----------------

Rim sherd; vertical direct rim, round lip. Rd: 12.00 cm 3/32; Wd: 0.52 cm; H₁: 4.96 + x cm. Throwing lines inside; smoothed on the wheel. Another, Rd: 12.00 cm 3/16.

No. 11: jar (Fig. 21:2), Inv. No. C-0429 [001]

Uncoated	Nile B ₂	W ₂
----------	---------------------	----------------

Rim sherd; vertical everted compound rim. Rd: 16.00 cm 1/8; Nd: 3.00 cm; Wd: 0.60 cm; H₁: 5.30 + x cm. Throwing lines inside; smoothed on the wheel; eroded and salt incrustated.

No. 12: jar (Fig. 21:2), Inv. No. C-0429 (2) [002]

Uncoated	Nile B ₂	W ₂
----------	---------------------	----------------

Rim sherd; vertical direct rim, round lip. Rd: 12.00 cm 3/32; Wd: 0.70 cm; H₁: 3.50 + x cm. Throwing lines inside; smoothed on the wheel; eroded.

No. 13: jar (Fig. 21:2), Inv. No. C-0429 (4) [006]

Uncoated	Nile B ₂	W ₂
----------	---------------------	----------------

Rim fragment; everted direct rim. Rd: 10.00 cm 1/4; Wd: 0.58 cm; H₁: 5.20 + x cm.

Throwing lines inside; smoothed on the wheel. Others, Rd: 8.00 cm 1/8, Rd: 9.00 cm 3/4, Rd: 9.50 cm 7/32.

No. 14: jar, Inv. No. C-0429 [022]

Uncoated Nile B₂ W₂

Rim fragment; slightly everted direct rim. Rd: 10.00 cm 1/8; Wd: 0.65 cm. Throwing lines inside; smoothed on the wheel.

No. 15: jar (Fig. 21:2), Inv. No. C-0429 (4) [011]

Uncoated Nile B₂ W₂

Rim fragment; everted articulated exterior rim, modelled lip. Rd: 11.00 cm 1/8; Wd: 0.90 cm; H₁: 3.30 + x cm. Throwing lines inside; smoothed on the wheel.

No. 16: jar, Inv. No. C-0429 [018]

Uncoated Nile B₂ Ha₂

Handle fragment. Md: 12.00 cm; H₁: 6.40 + x cm; Hd: 2.60 x 2.00 cm; single strap; smoothed. Another, Hd: 2.70 x 2.20 cm.

No. 17: jar, Inv. No. C-0429 [013]

Uncoated Nile B₂ W₂ W

Base fragment; flattened. Md: 7.00 + x cm; Wd: 0.80 cm; H₁: 4.00 + x cm. Throwing lines inside; smoothed on the wheel.

No. 18: jar, Inv. No. C-0429 [009]

Uncoated Nile B₂ W₂ W

Base fragment; round. Wd: 1.00 cm; H₁: 2.80 + x cm. Finger marks inside; smoothed on the wheel.

No. 19: jar, Inv. No. C-0429 [010]

Uncoated Nile B₂ W₂ W

Base fragment; rounded. Wd: 1.30 cm; H₁: 2.90 + x cm. Throwing lines inside; smoothed on the wheel; eroded outside.

No. 20: amphora, Inv. No. C-0429 [016]

Uncoated Nile B₂ Ha₂

Handle fragment; attached upper body to shoulder vertical loop handle. Wd: 0.50 cm; H₁: 6.80 + x cm; Hd: 2.35 x 1.45 cm; single strap; smoothed.

No. 21: storage jar (Fig. 21:2), Inv. No. C-0429 (4) [003]

Uncoated Nile B₂ W₂

Rim fragment; inverted articulated exterior rim, modelled lip. Rd: 24.00 cm 3/32; Wd: 0.70 cm; H₁: 3.70 + x cm. Throwing lines inside; smoothed on the wheel.

Pottery with special functions

No. 22: bakery tray (Fig. 21:2), Inv. No. C-0429 (4) [007]

Uncoated Nile C₁ W₁ H

Rim and base fragment; everted direct rim. Rd: 18.00 cm 1/8; 20.00 cm 3/32; Wd: 1.30 cm; H₁: 3.90 cm. Throwing lines inside; smoothed on the wheel; eroded. Another (rim), Rd: 16.00 cm 3/32.

No. 23: tray (Fig. 21:2), Inv. No. C-0429 (4) [010]

Uncoated	Nile C ₂	Ha ₁
----------	---------------------	-----------------

Fragment (reconstructed shape). D: 34.00 cm 1/16; H₁: 2.60 cm.

Egyptian votive ware

No. 24: model jar (Fig. 21:2), Inv. No. P0757A (Drawing No. 0300)

BP	Nile B ₂	W ₂	W	ox.	2
----	---------------------	----------------	---	-----	---

Incomplete; no rim preserved; convex side walls, round base. Md: 5.80 cm; Wd: 0.45 cm; H₁: 5.00 + x cm; H₂: 2.40 + x cm. Surface colour: 5YR 6/4 light reddish brown; 2.5YR 6/4 light reddish brown slip. Break: light grey core; reddish brown oxidation zones. Technical details: throwing lines inside and outside. Surface treatment: polished, low lustre.

Egyptian marls,

household ware

No. 25 : amphora, Inv. No. C-0429 [017]

Uncoated	Marl F	Ha ₂
----------	--------	-----------------

Handle fragment; attached vertical loop handle. Hd: 3.70 x 2.60 cm; oval in section; 1; single strap; smoothed; eroded.

Body sherds, Nile B₂: 1.20 dm²; Nile C₂: 0.10 dm²; Marl A₄: 0.30 dm²; Marl F: 0.60 dm²; Marl F s: 0.10 dm²; Marl F + ochre: 0.20 dm². III? Mixed, body sherds: 0.10 dm².

b) North Sinai/South Palestine pottery

No. 26: amphora, II.TG 08, body sherds: 0.20 dm².

No. 27: amphora, II.TG 10, body sherds: 0.10 dm².

b) Imported pottery

Levantine fine ware

No. 28: juglet (Fig. 21:2), Inv. No. P0746A (Drawing No. 0704)

RP	IV.TG 52 (= TD IV.19 c)	W ₂	---	ox.	3
----	-------------------------	----------------	-----	-----	---

Rim sherd; everted rim, trimmed lip. Rd: 6.00 cm ¼; Wd: 0.50 cm; H₁: 1.60 + x cm. Surface colour: 10R 5/6 red slip. Break: 5YR 7/8 reddish yellow. Technical details: throwing lines inside. Surface treatment: polished, medium lustre.

Levantine household ware

No. 29: amphora, IV.TG 01, body sherds: 0.10 dm².

No. 30: amphora, IV.TG 06, body sherds: 0.10 dm².

No. 31: amphora, IV.TG 11, body sherds: 0.20 dm².

No. 32: amphora, IV.TG 18, body sherds: 0.30 dm².

No. 33: amphora, IV.TG 23, body sherds: 0.10 dm².

No. 34: amphora, IV.TG 51 (= TD IV.19), body sherds: 0.10 dm².

No. 35: amphora, IV.TG 61 overfired, body sherds: 0.20 dm².

Cypriote household ware

No. 36: amphora, VI.TG 40, body sherds: 0.10 dm².

No. 37: amphora, VI.TG 44, body sherds: 0.10 dm².

No. 38: amphora (Fig. 21:2), Inv. No. P1269A (Drawing No. 0707)

Uncoated	VI.TG 49	W ₂	---	ox.	3
----------	----------	----------------	-----	-----	---

Shoulder sherd; "torpedo" type. Md: 27.00 cm 1/16; Wd: 0.70 cm; H₁: 4.30 + x cm. Surface colour: 5YR 7/4 pink. Break: 5YR 6/6 reddish yellow. Technical details: throwing lines inside. Surface treatment: smoothed on the wheel.

Aegean fine ware***Black-on-Red II (IV) ware*****No. 39: juglet (Fig. 21:3), Inv. No. P7063A** (Drawing No. 0395)

BPMO	VII.TG 45	W ₂	---	ox.	3
------	-----------	----------------	-----	-----	---

Rim sherd; everted direct rim. Rd: 3.50 cm $\frac{1}{4}$; Wd: 0.30 cm; H₁: 1.10 + x cm.

Surface colour: 5YR 6/4 light reddish brown slip. Break: 2.5YR 6/6 light red.

Technical details: throwing lines inside. Decoration: a painted band on the rim inside and outside, 2 mm wide, 5YR 3/1 very dark grey. Surface treatment: polished, low lustre.

No. 40: juglet (Fig. 21:3), Inv. No. P7065A (before Inv. No. P0752A. Drawing No. 0388)

RP[MO]	VII.TG 45	W ₂	---	ox.	3
--------	-----------	----------------	-----	-----	---

Neck fragment. Nd: 4.00 cm; Wd: 0.35 cm; H₃: 2.60 + x cm. Surface colour: 10R 5/6 red slip. Break: 2.5YR 5/6 red. Technical details: throwing lines inside. Decoration: no decoration in the part preserved. Surface treatment: polished, medium lustre.**No. 41: juglet (Fig. 21:3), Inv. No. P0863A** (Drawing No. 0391)

BP[MO]	VII.TG 45	W ₂	W	ox.	3
--------	-----------	----------------	---	-----	---

Base fragment; flat base. Bd: 4.00 cm; Md: 6.20 cm; Wd: 0.40 cm; H₁: 1.70 + x cm.

Surface colour: 2.5YR 5/4 reddish brown slip. Break: 2.5YR 6/6 light red inside; 2.5YR 6/8 light red outside. Technical details: throwing lines inside. Decoration: ---. Surface treatment: polished, low lustre.

No. 42: juglet, Inv. No. P0752A (Drawing No. 0388)

RPMO	VII.TG 45	W ₂	---	ox.	3
------	-----------	----------------	-----	-----	---

Body sherd. Md: ca. 6.00 cm; Wd: 0.35 cm; H₁: 3.50 + x cm. Surface colour: 10R 5/6 red slip. Break: 2.5YR 5/6 red. Technical details: throwing lines inside. Decoration: horizontally painted lines, 1 mm wide, 2.5YR 3/1 dark reddish grey. Surface treatment: polished, medium lustre.***Black-on-Red III (V) ware*****No. 43: juglet (Fig. 21:3), Inv. No. P0783A** (Drawing No. 0657)

BPMO	VII.TG 39 c.	W ₂	---	ox.	3
------	--------------	----------------	-----	-----	---

Neck and handle fragment; compound neck and swelling of the handle. Nd: 2.10 cm; Wd: 0.25 cm; H₃: 3.00 + x cm. Surface colour: 2.5YR 5/4 reddish brown slip. Break: 2.5YR 6/4 light reddish brown. Technical details: throwing lines inside. Decoration: horizontally painted lines, 1.50-3 mm wide, 2.5YR 3/1 dark reddish grey. Surface treatment: polished, high lustre. *Find No. 019.****Aegean household ware*****No. 44: amphora, VII.TG 58, body sherds: 0.10 dm².****II.- Finds*****Personal object*****No. 45: bead, Inv. No. F0380A.** Fragmentary; faience. 0.60 x 0.30 cm; colour: 10R 6/4 pale red; cylindrical shape. *Find No. 012.****Stone vessel*****No. 46: pot (Fig. 21:3), Inv. No. F0569A** (Drawing No. 0346/1063). Base fragment, round shape; limestone. Weight: 432.00 gr. Bd: ca. 5.00 cm; Wd: 1.60 cm; eroded. *Find No. 022.*

Suspended weight

No. 47: weight (Fig. 21:3), Inv. No. F0347 (Drawing No. 0270). Complete; limestone. 2.90 x 4.30 cm. Manufacturing technique: ground to shape. Characteristics: frontal view shape: geometric, cylindrical; side view shape: double concave. SCA No. 2024. Find No. 012 (a).

Tool

No. 48: pestle (Fig. 21:3), Inv. No. F0930A (Drawing No. 0940). Fragmentary; limestone. 4.30-5.00 x 7.0 cm; polished surface.

Objects of unknown use

No. 49: fragment of an object, Inv. No. F0348A. Iron?; melted. 3.50 x 1.40 x 0.70 cm; flat; blade of a knife? *Find No. 012 (b)*.

No. 50: fragment of an object, Inv. No. F0362A. Bronze. 1.80 x 1.00 x 0.80 cm.

No. 51: fragment of an object, Inv. No. F0363A. Iron; melted. 1.80 x 1.80-1.20 x 0.50 cm. *Find No. 018*.

No. 52: fragment of an object, Inv. No. F0404A. Lead. 1.80 x 1.60 x 0.70 cm; part of a net weight? *Find No. 023*.

No. 53: fragment of an object (Fig. 21:4), Inv. No. F0939A (Drawing No. 0944). Fragmentary; quartzite. 2.20 x 1.50 x 1.20 cm; a groove, 4 mm deep; a face is polished.

Product

No. 54: metal slag, Inv. No. F0381A. *Find No. 021*.

L0069 (Fig. 22)**I.- Pottery****a) Egyptian pottery****Nile silt clay**

Body sherds, Nile B₂, Nile C₂.

b) Imported pottery**Levantine household ware**

No. 1: amphora, Inv. No. P0718A (Drawing No. 0317)

Uncoated	IV.TG 11	W ₂	---	ox.	3
----------	----------	----------------	-----	-----	---

Base and body fragment; rounded base. Md: 36.00 + x cm; Wd: 0.85 cm; H₁: 30.00 + x cm. Surface colour: --- (covered by fungus). Break: thick exterior, 5YR 4/1 dark grey; 5YR 6/6 reddish yellow interior. Technical details: throwing lines inside. Surface treatment: smoothed on the wheel.

Cypriote fine ware**Black-on-Red II (IV) ware**

No. 2: juglet (Fig. 22), Inv. No. P0053B (Drawing No. 0005. F1)

RPMO	VI.TG39	W ₂	W	ox.	3
------	---------	----------------	---	-----	---

Nearly complete; neck and rim no preserved; flat base. Nd: 1.00 cm; Md: 3.80 cm; Bd: 2.20 cm; Wd: 0.20 cm; H₁: 4.00 + x cm; H₂: 1.50 cm; H₃: 0.20 + x cm; Hd: 0.75 cm x 0.70 cm; round in section; 1; single strap. Surface colour: 2.5YR 5/6 red slip. Break: 5YR 6/6 reddish yellow. Decoration: horizontally and concentric painted lines, 2.5YR 2.5/1 reddish black. Surface treatment: polished, medium lustre. Observations: in the Abu Seifa exhibition room. *Find No. 001*.

*White Painted ware?***No. 3: amphora**, Inv. No. P0717A (Drawing No. 0654)

WPMO	VI.TG 40 c.	W ₂	---	ox.	3
------	-------------	----------------	-----	-----	---

Handle and body fragment; basket handle. Md: 20.00 cm 1/8; Wd: 0.70 cm; H₁: 7.90 + x cm; Hd: 2.00 x 2.80 cm; single strap. Surface colour: 2.5Y 7/4 pale yellow slip. Break: 5Y 7/3 pale yellow. Decoration: a painted line on the handle, 19 mm wide, 2.5Y 5/2 greyish brown. Surface treatment: polished, low lustre.

II.- Finds**Object of unknown use**

No. 4: fragment of an object, Inv. No. F0349A. Faience; moulded. 2.60 x 1.90-1.50 x 0.60 cm; colour: Chart 2 for gley 10B 5/1 bluish grey, and other parts in blue. Frontal view shape: complex; side view shape: double-convex. Part of a wdjat? *Find No. 011.*

L0084 (Fig. 23)**Pottery****a) Egyptian pottery****Nile silt clay****Household ware****No. 1: bowl (Fig. 23:1)**, Inv. No. P0510A (Drawing No. 0222)

Uncoated	Nile B ₂ /E ₁	W ₂	---	ox.	2
----------	-------------------------------------	----------------	-----	-----	---

Rim and body sherds; incurved rim. Rd: 22.00 cm 5/64; Wd: 0.75 cm; H₁: 9.50 + x cm. Surface colour: 5YR 6/3 light reddish brown. Break: 7.5YR 5/4 brown. Technical details: throwing lines inside. Surface treatment: smoothed on the wheel.

No. 2: bowl (Fig. 23:1), Inv. No. C-0281 [001]

Uncoated	Nile B ₂	W ₂
----------	---------------------	----------------

Rim and body fragment, inverted direct rim. Rd: 24.00 cm 3/32; Wd: 0.60 cm; H₁: 7.70 + x cm; smoothed on the wheel.

No. 3: bowl (Fig. 23:1), Inv. No. C-0295 [003]

Uncoated	Nile B ₂	W ₂
----------	---------------------	----------------

Rim sherd; vertical direct rim. Rd: 17.00 cm 5/32; Wd: 0.50 cm; H₁: 6.80 + x cm; smoothed on the wheel.

No. 4: bowl (Fig. 23:1), Inv. No. C-0200 [006]

Uncoated	Nile B ₂	W ₂
----------	---------------------	----------------

Rim sherd, everted articulated exterior rim, modelled lip. Rd: 32.00 cm 1/16; Wd: 0.90 cm; H₁: 3.30 + x cm; smoothed on the wheel. Another, Rd: 30.00 cm 1/16.

No. 5: bowl (Fig. 23:1), Inv. No. C-0295 [002]

Uncoated	Nile C ₁	W ₂
----------	---------------------	----------------

Rim sherd; everted articulated interior rim, beveled lip. Rd: 18.00 cm 1/16; Wd: 0.60 cm; H₁: 3.40 + x cm; smoothed on the wheel.

No. 6: deep bowl (Fig. 23:2), Inv. No. P0018A (Drawing No. 0218)

Uncoated	Nile B ₂	W ₁	base finished on the wheel	ox.	2
----------	---------------------	----------------	----------------------------	-----	---

Complete, fragmentary; mended; everted direct rim; pointed base. Rd: 12.00 cm 1/2; Wd: 0.35 cm; H₁: 10.50 cm. VI: 114. Surface colour: 10R 5/6 red. Break: 5YR 5/8 yellowish red. Technical details: grooves on the exterior made with a tool while throwing. Surface

treatment: smoothed on the wheel.

No. 7: deep bowl (Fig. 23:2), Inv. No. P0035A (Drawing No. 0221)

Uncoated	Nile B ₂	W ₂	base finished on the wheel	ox.	2
----------	---------------------	----------------	----------------------------	-----	---

Complete, fragmentary; mended; everted direct rim; pointed base. Rd: 11.00 cm; Wd: 0.30 cm; H₁: 7.50 cm. VI: 147. Surface colour: 7.5YR 6/4 light brown. Break: 7.5 YR 5/6 strong brown. Surface treatment: smoothed on the wheel. Others (rim), Rd: 12.00 cm ¼; (base), 1/1.

No. 8: cup (Fig. 23:2), Inv. No. C-0154 [004]

Uncoated	Nile C ₁	W ₂
----------	---------------------	----------------

Rim sherd; everted direct rim. Rd: 10.00 cm 5/32; Wd: 0.60 cm; H₁: 3.50 + x cm; smoothed on the wheel.

No. 9: cooking pot (Fig. 23:2), Inv. No. C-0154 [001]

Uncoated	Nile E ₂	W ₂
----------	---------------------	----------------

Body fragment; carinated wall. Md: ca. 20.00 cm; Wd: 0.60-0.90 cm; H₁: 14.00 + x cm. Throwing lines inside; smoothed on the wheel. Smoked outside.

No. 10: juglet (Fig. 23:3), Inv. No. P0190B (Drawing No. 0157)

RS	Nile E ₂	W ₂	W	ox.	2
----	---------------------	----------------	---	-----	---

Base and body fragment; slender type with round base. Nd: 2.40 cm; Md: 6.20 cm; Wd: 0.35 cm; H₁: 9.80 + x cm; H₂: 3.30 cm. Surface colour: 10R 4/8 red slip. Break: 2.5YR 6/8 red. Surface treatment: smoothed on the wheel. Observations: in the Abu Seifa exhibition room.

No. 11: jug (Fig. 23:3), Inv. No. P0350A (Drawing No. 0147)

RS	Nile B ₂ fine	W ₂ + Ha ₂	base finished on the wheel	ox.	2
----	--------------------------	----------------------------------	----------------------------	-----	---

Incomplete, fragmentary; carinated jug with pointed base; handle fragment; oval shaped, one handle, single strap; no rim preserved. Nd: 6.50 cm; Md: 11.00 cm; Wd: 0.60 cm; H₁: 7.20 + x cm; H₂: 5.30 cm; Hd: 0.80 x 1.50 cm. Surface colour: 10R 4/6 red. Break: 2.5YR 5/8 red. Technical details: throwing lines inside and outside. Surface treatment: smoothed on the wheel.

No. 12: jar (Fig. 23:4), Inv. No. P0191A (Drawing No. 0159)

Uncoated	Nile B ₂	W ₁	W	ox.	2
----------	---------------------	----------------	---	-----	---

Incomplete, fragmentary; globular jar, round base. Nd: 4.00 cm; Md: 12.50 cm; Wd: 0.40 cm; H₁: 14.00 + x cm; H₂: 6.60 cm; H₃: 1.00 + x cm. Surface colour: 2.5YR 5/6 red. Break: 2.5YR 5/6 red. Surface treatment: smoothed on the wheel.

No. 13: jar (Fig. 23:4), Inv. No. P0041A (Drawing No. 0219)

Uncoated	Nile B ₂	W ₂	W	ox.	2
----------	---------------------	----------------	---	-----	---

Nearly complete, fragmentary; mended; globular type; everted direct rim. Rd: 8.00 cm 1/4; Nd: 7.50 cm; Md: 16.50 cm; Wd: 0.70 cm; H₁: 15.80 cm; H₂: 8.00 cm. VI: 105. Surface colour: 2.5YR 5/4 weak red. Break: 2.5YR 6/6 red. Technical details: throwing lines on the exterior surface. Surface treatment: smoothed on the wheel. Another (rim), Rd: 10.00 cm 3/64.

No. 14: jar (Fig. 23:4), Inv. No. P0019A (Drawing No. 0148)

Uncoated	Nile B ₂	W ₂	W	ox.	2
----------	---------------------	----------------	---	-----	---

Shoulder, round base and body fragment. Md: 27.00 cm; Wd: 0.75 cm; H₁: 23.80 + x cm;

H₂: 13.00 cm. Break: 7.5YR 6/2 pinkish grey core; 2.5YR 6/6 red oxidation zones. Surface colour: 2.5YR 6/6-5/6 red. Surface treatment: smoothed on the wheel.

No. 15: jar (Fig. 23:4), Inv. No. P0562A (Drawing No. 0221)

Uncoated	Nile B ₂	W ₂	base finished on the wheel	ox.	2
----------	---------------------	----------------	----------------------------	-----	---

Base (pointed) and body fragment. Md: 17.00; Wd: 0.55 cm; H₁: 11.00 + x cm. Surface colour: 7.5 YR 5/3 brown. Break: 7.5YR 6/4 light brown. Technical details: throwing lines inside; made in parts; a groove on the lower part. Surface treatment: smoothed on the wheel.

No. 16: jar (Fig. 23:4), Inv. No. C-0154 [003]

Uncoated	Nile B ₂	W ₂
----------	---------------------	----------------

Rim sherd; vertical direct rim, rounded. Rd: 10.00 cm 5/32; Wd: 0.60 cm; H₁: 2.40 + x cm; smoothed on the wheel.

No. 17: jar (Fig. 23:4), Inv. No. P0021A (Drawing No. 0218)

Uncoated	Nile C ₁	W ₁	---	ox.	2
----------	---------------------	----------------	-----	-----	---

Neck, rim and shoulder fragment; slightly everted direct rim. Rd: 10.00 cm; Nd: 9.80 cm; Wd: 0.90 cm; H₁: 8.00 + x cm. Surface colour: 7.5YR 6/4 light brown. Break: 2.5YR 5/6 red core; 7.5YR 5/4 brown oxidation zones. Technical details: undulated exterior wall. Surface treatment: smoothed on the wheel.

No. 18: jar (Fig. 23:5), Inv. No. C-0295 [001]

Uncoated	Nile B ₂ /C ₁	W ₂
----------	-------------------------------------	----------------

Rim sherd; slightly inverted direct rim. Rd: 8.00 cm 7/32; Wd: 0.50 cm; H₁: 2.80 + x cm; self slip; smoothed on the wheel.

No. 19: storage jar (Fig. 23:5), Inv. No. C-0295 [005]

Uncoated	Nile B ₂	W ₂
----------	---------------------	----------------

Rim sherd; vertical articulated exterior rim, rolled lip. Rd: 32.00 cm 1/8; Wd: 0.50-0.80 cm; H₁: 6.20 + x cm; smoothed on the wheel.

No. 20: storage jar (Fig. 23:5), Inv. No. C-0200 [002]

Uncoated	Nile B ₂	W ₂
----------	---------------------	----------------

Rim sherd, slightly inverted articulated exterior rim, folded lip. Rd: 24.00 cm 1/16; Wd: 0.80 cm; H₁: 4.70 + x cm; smoothed on the wheel. Another, Rd: 24.00 cm 1/4.

No. 21: amphora, Inv. No. C-0295 [007]

Uncoated	Nile B ₂	W ₂
----------	---------------------	----------------

Body and shoulder fragment, "torpedo" type. Wd: 0.80 cm; H₁: 6.00 + x cm; throwing lines inside and outside; smoothed on the wheel.

Pottery with special functions

No. 22: bakery tray (Fig. 23:5), Inv. No. P0576A (Drawing No. 0231/0239)

Uncoated	Nile C ₂	W ₁	Ha	ox.	2
----------	---------------------	----------------	----	-----	---

Complete, fragmentary; everted direct rim. Rd: 26.00 cm 5/32; Bd: 22.00 cm 3/32; Wd: 1.90 cm; H₁: 5.60 cm. VI: 464. Surface colour: 7.5YR 6/4 light brown. Break: 5YR 4/1 dark grey. Surface treatment: smoothed.

No. 23: bakery tray (Fig. 23:5), Inv. No. P0579A (Drawing No. 0240)

Uncoated	Nile C ₂	W ₁	Ha	ox.	2
----------	---------------------	----------------	----	-----	---

Complete, fragmentary; everted direct rim. Rd: 16.00 cm 1/8; Bd: 14.00 cm 3/32; Wd: 1.20 cm; H₁: 3.50 cm. VI: 457. Surface colour: 2.5YR 6/6 light red. Break: 2.5YR 4/6 red core; 2.5YR 5/8 red oxidation zones. Surface treatment: smoothed. Another (base only), Bd: 22.00 cm.

No. 24: bakery tray (Fig. 23:5), Inv. No. C-0200 [009]

Uncoated	Nile C ₁	W ₁
----------	---------------------	----------------

Rim sherd, everted articulated exterior rim, modelled lip. Rd: 32.00 cm 5/64; Wd: 1.20 cm; H₁: 3.20 + x cm; smoothed.

Egyptian marls

Household ware

No. 25: jar (Fig. 23:5), Inv. No. C-0281 [003]

Uncoated	Marl A ₄	W ₂
----------	---------------------	----------------

Rim and shoulder fragment; vertical direct rim. Rd: 8.00 cm 5/32; Wd: 0.22 cm; H₁: 3.60 + x cm. Throwing lines inside; smoothed on the wheel.

No. 26: jar (Fig. 23:6), Inv. No. P1242A (Drawing No. 0632)

Uncoated	Marl A ₄	W ₂	---	ox.	3
----------	---------------------	----------------	-----	-----	---

Neck and body fragments. Nd: 5.10 cm; Md: 10.00 cm; Wd: 0.35 cm; H₁: 8.00 + x cm. Surface colour: 7.5YR 7/3 pink-6/3 light brown self slip. Break: 7.5YR 6/3 light brown. Technical details: ridges inside; ribbed surface. Surface treatment: smoothed on the wheel.

No. 27: jar (Fig. 23:6), Inv. No. P1203A (Drawing No. 0632)

Uncoated	Marl A ₄	W ₂	---	ox.	3
----------	---------------------	----------------	-----	-----	---

Rim, neck and body fragment. Rd: 10.50 cm 1/32; Nd: 10.00 cm; Md: 14.00 + x cm; Wd: 0.30 cm; H₁: 3.00 + x cm. Surface colour: 2.5Y 7/3 pale yellow self slip. Break: 2.5Y 7/3 pale yellow. Technical details: rilling lines outside and inside. Surface treatment: smoothed on the wheel.

No. 28: jar?, Inv. No. C-0295 [008]

Uncoated	Marl F	W ₂
----------	--------	----------------

Swelling of a handle and wall fragment; H₁: 4.00 + x cm; smoothed.

No. 29: amphora (Fig. 23:6), Inv. No. C-0104 [001]

Uncoated	Marl F	W ₂
----------	--------	----------------

Rim and shoulder fragment; vertical direct rim, round lip. Rd: 10.00 cm 1/4; Wd: 0.70 cm; H₁: 3.60 + x cm. Throwing lines inside; smoothed on the wheel.

No. 30: amphora (Fig. 23:6), Inv. No. C-0295 [004]

Uncoated	Marl F v.s.	W ₂
----------	-------------	----------------

Rim sherd; vertical articulated exterior rim. Rd: 12.00 cm 1/8; Wd: 0.40 cm; H₁: 2.70 + x cm. Throwing lines inside; smoothed on the wheel.

Body sherds, Nile B₁: 0.50 dm²; Nile B₂: 26.00 dm²; Nile C₁: 4.00 dm²; Nile C₂: 0.20 dm²; Marl A₄: 0.50 dm²; Marl F: 1.90 dm²; Marl F s.: 0.50 dm².

b) North Sinai/South Palestine pottery

Household ware

No. 31: amphora, II.TG 08, body sherds: 0.25 dm².

No. 32: amphora, II.TG 09, body sherds: 0.30 dm².

No. 33: amphora, II.TG 10, body sherds: 0.40 dm².

c) Imported pottery

Levantine household ware

No. 34: jar, Inv. No. C-0200 [004]

Uncoated	IV.TG 11	Ha ₂
----------	----------	-----------------

Handle fragment; loop handle; Hd: 1.60 x 1.10 cm; single strap; smoothed.

No. 35: amphora (Fig. 23:6), Inv. No. C-0295 (2) [001]

Uncoated	IV.TG 11	W ₂ + Ha ₂
----------	----------	----------------------------------

Shoulder, body and handle fragment, attached from shoulder to body. Md: 24.00 cm; Wd: 0.8 cm; H₁: 16.00 + x cm; Hd: 3.10 x 2.40 cm; single strap; throwing lines inside; smoothed on the wheel.

No. 36: amphora, IV.TG 11, body sherds: 2.40 dm².

No. 37: amphora, IV.TG 36, body sherds: 0.20 dm².

No. 38: amphora (Fig. 23:6), Inv. No. P0719A (Drawing No. 0800)

Uncoated	IV.TG.51(= TD IV.19)	W ₂	---	ox.	3
----------	----------------------	----------------	-----	-----	---

Shoulder and body fragment, "torpedo" type. Md: 32.00 cm; Wd: 1.00 cm; H₁: 55.50 + x cm; H₂: 26.00 cm. Surface colour: 7.5YR 7/4 pink. Break: 7.5YR 7/4 pink on the exterior; 7.5YR 5/1 grey on the interior. Throwing lines inside; smoothed on the wheel.

No. 39: amphora, IV.TG 52 (= TD IV.19 c.), body sherds: 0.70 dm².

Phoenician household ware

No. 40: amphora (Fig. 23:7), Inv. No. C-0200 [010]

Uncoated	IV.TG 22 = IV.Phoen?04	W ₂
----------	------------------------	----------------

Shoulder and body fragment; "torpedo" type. Md: 22.00 cm; Wd: 1.10 cm; throwing lines inside; smoothed on the wheel.

Cypriote fine ware

Black-on-Red II (IV) ware

No. 41: juglet (Fig. 23:7), Inv. No. P0196A (Drawing No. 0008)

RPMO	VI.TG 42	W ₂	---	ox.	3
------	----------	----------------	-----	-----	---

Body sherd. Md: 8.00 + x cm; Wd: 0.22 cm; H₁: 2.20 + x cm. Surface colour: 10R 5/8 red. Break: 2.5 YR 5/8 red. Very fine ridges on the interior. Decoration: horizontally painted lines, 5YR 2.5/1 black. Surface treatment: polished, medium lustre.

Aegean fine ware

Black-on-Red ware

No. 42: juglet (Fig. 23:7), Inv. No. P0378A (Drawing No. 0146)

RP[MO]	VII.TG 39	W ₂	W	ox.	3
--------	-----------	----------------	---	-----	---

Base and body fragment; flat base. Md: 4.50 + x cm; Bd: 3.00 cm 1/2; Wd: 0.30 cm; H₁: 1.75 + x cm. Surface colour: 10R 5/6 red slip. Break: 2.5YR 5/4 weak red. Decoration: ---. Surface treatment: polished, medium lustre.

II.- Finds

Objects of unknown use

No. 43: fragment of an object, Inv. No. F1041A. Faience; destroyed.

No. 44: fragment of an object, Inv. No. F1042A. Faience; destroyed.

Tool

No. 45: sharpener, Inv. No. F0959A. Pumice.

L0169 (Fig. 24)**I.- Pottery****a) Egyptian pottery**

Nile silt clay

Household ware

No. 1: jar (Fig. 24), Inv. No. C-0493 [001]

Uncoated	Nile B ₂	W ₂
----------	---------------------	----------------

Rim sherd; vertical direct rim. Rd: 10.00 cm 3/16 cm; Wd: 0.65 cm; H₁: 4.00 + x cm; throwing lines inside; smoothed on the wheel; eroded. Another, Rd: 10.00 cm 1/8 cm.

Body sherds, Nile B₁: 0.10 dm²; Nile B₂: 8.70 dm²; Nile C₂: 2.90 dm²; Marl A₄: 0.10 dm².

b) North Sinai/South Palestine pottery

household ware

No. 2: amphora, II.TG 10, body sherds: 0.20 dm².

c) Imported pottery

household ware

No. 3: amphora, IV.TG 36, body sherds: 0.20 dm².

II.- Finds**Product**

No. 4: faience slag, Inv. No. F0738A.

L0176 (Fig. 25)**I.- Pottery****a) Egyptian pottery**

Nile silt clay

Household ware

No. 1: jar (Fig. 25), Inv. No. C-0444 [001]

Uncoated	Nile B ₂	W ₂
----------	---------------------	----------------

Rim sherd; vertical direct rim, round lip. Rd: 8.00 cm 5/32; Wd: 0.50 cm; H₁: 2.70 + x cm. Throwing lines inside; eroded. Others, Rd: 8.00 cm 3/32, Rd: 10.00 cm 3/32.

No. 2: jar, Inv. No. C-0444 [004]

Uncoated	Nile B ₂	W ₂	W
----------	---------------------	----------------	---

Base and wall fragment; round base. Md: 7.00 + x cm; Wd: 0.70 cm; H₁: 3.40 + x cm. Throwing lines inside; eroded.

Pottery with special functions

No. 3: lid (Fig. 25), Inv. No. C-0444 [003]

Uncoated	Nile B ₂	W ₂
----------	---------------------	----------------

Rim and wall fragment; everted direct rim, round lip. Rd: 24.00 cm 3/16; Wd: 0.80 cm; H₁: 2.90 + x cm. Throwing lines inside; eroded.

No. 4: tray (Fig. 25), Inv. No. P1011A (Drawing No. 0367)

Uncoated	Nile C ₂	Ha ₁	H	re.	2
----------	---------------------	-----------------	---	-----	---

Fragment. D: 56.00 cm 1/8; Wd: 2.90-3.40 cm; H₁: 6.00 cm. Surface colour: 10R 6/4 pale red. Break: 10R 2.5/1 reddish black. Surface treatment: uneven. Eroded.

Body sherds, Nile B₂: 14.00 dm²; Nile C₂: 0.80 dm².

b) Imported pottery

Levantine household ware

No. 5: amphora, Inv. No. C-0298, similar to IV.TG 06, body sherd: 0.25 dm².

No. 6: amphora, Inv. No. C-0315, IV.TG 07, body sherd: 0.40 dm².

No. 7: amphora, Inv. No. C-0339, similar to IV.TG 18, body sherds: 0.20 dm².

No. 8: amphora, Inv. No. C-0331, IV.TG 51 (= TD IV.19), body sherd: 0.20 dm².

No. 9: amphora, Inv. No. C-0315, similar to TD IV.08, body sherds: 0.15 dm².

Cypriote household ware

No. 10: amphora, Inv. No. C-0444, VI.TG 43, body sherd: 0.10 dm².

II.- Finds

Tool

No. 11: grinding stone, hand (Fig. 25), Inv. No. F1077A (before F0225A. Drawing No. 1022). Complete; sandstone. 8.70 x 8.80 x 3.30-2.20 cm.

Product

No. 12: faience slag, Inv. No. F1051A.

L0179 (Fig. 26)

I.- Pottery

a) Egyptian pottery

Nile silt clay

Egyptian fine ware

No. 1: juglet, Inv. No. C-0428 (2) [001]

RP	Nile B ₂	W ₂
----	---------------------	----------------

Body sherd; Md: ca. 9.00 cm; Wd: 0.40 cm; H₁: 3.10 + x cm; throwing lines inside; red slip surface; polished.

Egyptian household ware

No. 2: bowl (Fig. 26), Inv. No. C-0312 [001]

UncRS	Nile B ₂	W ₂
-------	---------------------	----------------

Rim sherd; inverted direct rim. Rd: 26.00 cm 1/16; Wd: 0.60 cm; H₁: 3.26 + x cm; red slipped interior; throwing lines outside; smoothed on the wheel.

No. 3: bowl (Fig. 26), Inv. No. C-0312 [002]

Uncoated	Nile B ₂	W ₂
----------	---------------------	----------------

Rim sherd; everted direct rim. Rd: 36.00 cm 1/16; Wd: 0.57 cm; H₁: 2.51 + x cm; overfired, eroded and smoked inside. Another, Rd: 24.00 cm 3/32.

No. 4: bowl (Fig. 26), Inv. No. C-0312 [003]

Uncoated	Nile C ₂	W ₂
----------	---------------------	----------------

Rim sherd; everted direct rim. Rd: 48.00 cm 1/32; Wd: 1.19 cm; H₁: 3.34 + x cm; throwing lines outside; smoothed on the wheel. Others, Nile B₂, Rd: 18.00 cm 1/16, Rd: 22.00 cm

3/32. Nile E₁, Rd: 24.00 cm 3/32.

No. 5: bowl (Fig. 26), Inv. No. C-0398 [004]

Uncoated	Nile E ₁	W ₂
----------	---------------------	----------------

Rim sherd; everted articulated exterior rim. Rd: 20.00 cm 3/32; Wd: 0.75 cm; H₁: 2.98 + x cm; throwing lines outside; smoothed on the wheel.

No. 6: jar (Fig. 26), Inv. No. C-0398 [008]

Uncoated	Nile E ₁	W ₂
----------	---------------------	----------------

Rim sherd; slightly inverted direct rim. Rd: 10.00 cm 1/16; Wd: 0.65 cm; H₁: 3.73 + x cm; throwing lines inside; smoothed on the wheel; eroded.

No. 7: jar (Fig. 26), Inv. No. C-0398 [002]

Uncoated	Nile C ₁	W ₂
----------	---------------------	----------------

Rim sherd; vertical direct rim. Rd: 12.00 cm 1/8; Wd: 0.54 cm; H₁: 4.55 + x cm; throwing lines inside; smoothed on the wheel; eroded. Others, Nile B₂, Rd: 10.00 cm 3/3. Nile C₁, Rd: 10.00 cm 3/16.

No. 8: jar, Inv. No. C-0398 [010]

Uncoated	Nile B ₂	W ₂	W
----------	---------------------	----------------	---

Base fragment; rounded base; Wd: 0.75 cm; H₁: 5.00 + x cm; throwing lines inside and outside; smoothed on the wheel.

Body sherds, Nile B₂: 7.50 dm²; Nile C₁: 1.10 dm²; Nile C₂: 1.20 dm²; Marl F v.s.

b) North Sinai/South Palestine pottery

Household ware

No. 9: juglet (Fig. 26), Inv. No. P0357A (Drawing No. 0186)

Uncoated	II.TG 10	W ₂	---	ox.	3
----------	----------	----------------	-----	-----	---

Rim sherd. Rd: 4.00 cm 1/32; Wd: 0.30 cm; H₁: 2.00 + x cm. Surface colour: 10YR 4/2 dark greyish brown. Break: 2.5Y 7/3 pale yellow. Throwing lines inside. Surface treatment: smoothed on the wheel.

No. 10: amphora, II.TG 10, body sherds.

c) Imported pottery

Levantine household ware

No. 11: amphora, IV.TG 07, body sherds.

No. 12: amphora, IV.TG 36, body sherds.

No. 13: amphora, similar to IV.TG 36, body sherds.

No. 14: amphora, IV.TG 52 (=TD IV.19 c.), body sherds.

No. 15: amphora, IV.TG 53 (=TD IV.09), body sherds.

No. 16: amphora, Inv. No. C-0398 [009], IV.?, handle fragment, Hd: 1.75 x 1.20 cm.

No. 17: amphora, Inv. No. C-0398 [0009]

Uncoated	IV.burnt	---
----------	----------	-----

Handle fragment; loop handle. Hd: 1.76 x 1.19 cm; 1; single strap.

L0263 = L0222 (Fig. 27)

I.- Pottery

a) Egyptian pottery**Nile silt clay*****Fine ware*****No. 1: bowl** (Fig. 27), Inv. No. C-0496 (2) [001]RP | Nile B₂ | W₂Rim sherd; inverted direct rim. Rd: 20.00 cm 1/16; Wd: 0.90 cm; H₁: 3.30 + x cm; burnished surface.***Household ware*****No. 2: bowl**, Inv. No. C-0496Uncoated | Nile B₂ c. | W₂

Rim sherd; slightly vertical direct rim, trimmed lip. Rd: 22.00 cm 1/16; Wd: 0.70 cm; eroded.

No. 3: deep bowl? (Fig. 27), Inv. No. C-0496 (2) [003]Uncoated | Nile B₂ | W₂Rim sherd; everted articulated exterior rim. Rd: 20.00 cm 3/16; Wd: 0.70 cm; H₁: 6.00 + x cm; smoothed on the wheel; eroded. Another, Nile C₂, Rd: 26.00 cm 3/32; very eroded.**No. 4: bowl** (Fig. 27), Inv. No. C-0496 [002]Uncoated | Nile C₁ | W₂Rim sherd; everted direct rim. Rd: 26.00 cm 1/6; Wd: 1.10 cm; H₁: 1.98 + x cm; throwing lines outside; smoothed on the wheel; eroded inside and outside; smoked inside (used as a lid).**No. 5: cup** (Fig. 27), Inv. No. C-0496 [008]Uncoated | Nile B₂ | W₂Rim sherd; slightly inverted direct rim. Rd: 10.00 cm 3/32; Wd: 0.30 cm; H₁: 2.80 + x cm; throwing lines inside; smoothed on the wheel.**No. 6: jar** (Fig. 27), Inv. No. C-0496 [009]Uncoated | Nile B₂ | W₂Rim sherd; inverted direct rim. Rd: 10.00 cm 3/32; Wd: 0.60 cm; H₁: 3.20 + x cm; throwing lines inside; smoothed on the wheel. Another, Nile C₁, Rd: 12.00 cm 3/32.**No. 7: jar** (Fig. 27), Inv. No. C-0496 (2) [002]Uncoated | Nile C₂ | W₂Rim sherd; inverted articulated interior and exterior rim, round lip. Rd: 18.00 cm 3/32; Wd: 0.90 cm; H₁: 5.90 + x cm; throwing lines inside; smoothed on the wheel.**No. 8: jar** (Fig. 27), Inv. No. C-0496 [004]Uncoated | Nile C₁ | W₂Rim sherd; vertical direct rim. Rd: 12.00 cm 3/32; Wd: 0.70 cm; H₁: 2.60 + x cm; throwing lines inside; smoothed on the wheel; eroded inside.**No. 9: jar** (Fig. 27), Inv. No. C-0496 [007]Uncoated | Nile B₂ v.f. | W₂Rim sherd; everted direct rim. Rd: 6.00 cm 1/8; Wd: 0.40 cm; H₁: 1.24 + x cm; throwing lines inside; smoothed on the wheel.

Pottery with special functions

No. 10: bakery tray, Inv. No. C-0424 (2). Body sherds, Nile C₂, eroded.

Body sherds, Nile B₂: 18.25 dm²; Nile C₂: 2.10 dm²; Marl F: 0.10 dm²; Marl A₄.

b) North Sinai/South Palestine pottery**Household ware**

No. 11: amphora, II.TG 09, body sherds.

No. 12: amphora, II.TG 10, body sherds: 0.10 dm².

c) Imported pottery**Levantine household ware**

No. 13: amphora, IV.TG 03, body sherds: 0.10 dm².

No. 14: amphora, IV.TG 07, body sherds.

No. 15: amphora, Inv. No. C-0492 (2) [004]

Uncoated	IV.TG 07	Ha ₂ + W ₂
----------	----------	----------------------------------

Handle and body fragment; inserted vertical handle; single strap. Wd: 1.00 cm; H₁: 6.80 + x cm; Hd: 0.90 x 1.90 x 1.30 cm; throwing lines inside; smoothed.

No. 16: amphora, Inv. No. C-0612 [0004]

Uncoated	IV.TG 23	Ha ₂
----------	----------	-----------------

Handle fragment; eroded.

No. 17: amphora, IV.TG 36, body sherds.

Cypriote fine ware**Black-on-Red I (III) ware**

No. 18: juglet (Fig. 27), Inv. No. P0731A (Drawing No. 0658)

WP[MO]	VI.TG 42	Ha ₂	---	ox.	3
--------	----------	-----------------	-----	-----	---

Handle fragment; single strap. Hd: 1.15 x 0.65 cm. Surface colour: 5YR 6/6 reddish yellow slip. Break: 5YR 4/4 reddish brown. Throwing lines inside. Surface treatment: polished, medium lustre.

No. 19: juglet (Fig. 27), Inv. No. P0803A (Drawing No. 0951)

RP[MO]	VII.TG 45	W ₂	---	ox.	3
--------	-----------	----------------	-----	-----	---

Body sherd. Md: 10.30 + x cm; Wd: 0.20 cm; H₁: 1.70 + x cm. Surface colour: 2.5YR 5/6 red slip. Break: 2.5YR 6/6 light red. Throwing lines inside. Surface treatment: polished, medium lustre.

Cypriote household ware

No. 20: amphora, VI.TG 40, body sherds.

Aegean household ware

No. 21: amphora, VII.TG 46, body sherds.

II.- Finds**Object of unknown use**

No. 22: fragments (4) of an object, Inv. No. F0290A; faience. *Find No. 009.*

L0237 (Fig. 28)**I.- Pottery****a) Egyptian pottery****Nile silt clay****Household ware****No. 1: bowl (Fig. 28:1), Inv. No. C-0463 [001]**Uncoated | Nile B₂ | W₂Rim sherd; everted articulated exterior rim. Rd: 20.00 cm 3/32; Wd: 0.90 cm; H₁: 3.10 + x cm; throwing lines inside; wheel smoothed inside and outside; eroded. Another, Nile C₂, Rd: 22.00 cm 1/16.**No. 2: bowl, Inv. No. C-0463 (2)**Uncoated | Nile C₂ | W₂ | base finished on the wheelBase fragment; ring base (R₃). Bd: 16.00 cm 5/32; Wd: 1.40 cm.**No. 3: jar (Fig. 28:1), Inv. No. C-0470 [001]**Uncoated | Nile B₂ | W₂Rim sherd; inverted direct rim. Rd: 10.00 cm 3/32; Wd: 0.60 cm; H₁: 3.80 + x cm; throwing lines inside; smoothed on the wheel; eroded.**No. 4: jar (Fig. 28:1), Inv. No. C-0524 [001]**Uncoated | Nile B₂ | W₂Rim sherd; vertical direct rim. Rd: 10.00 cm 1/4; Wd: 0.70 cm; H₁: 4.92 + x cm; throwing lines inside; wheel smoothed inside and outside; eroded outside. Others, Nile B₂/C₁, Rd: 10.00 cm 5/32, Rd: 10.00 cm 3/32.**No. 5: storage jar, Inv. No. C-0470 [006]**Uncoated | Nile B₂ | Ha₂ + W₂Handle and wall fragment; body to body attached vertical loop handle; Wd: 1.70 cm; H₁: 6.00 + x cm; Hd: 3.85 x 2.20 cm; oval in section; 1; single strap; throwing lines inside; smoothed on the wheel; eroded.**No. 6: storage jar, Inv. No. C-0470 [005]**Uncoated | Nile B₂ | Ha₂ + W₂Handle and wall fragment; body to body attached vertical loop handle; Wd: 0.90 cm; H₁: 12.10 + x cm; Hd: 3.30 x 1.80 cm; oval in section; 1; single strap; throwing lines inside; smoothed on the wheel; eroded.**Pottery with special functions****No. 7: lid (Fig. 28:1), Inv. No. C-0470 [002]**Uncoated | Nile B₂ | W₂Rim sherd; everted direct rim. Rd: 26.00 cm 3/32; Wd: 1.00 cm; H₁: 4.30 + x cm; throwing lines inside; smoothed on the wheel; eroded. Another, Rd: 22.00 cm 3/32.**No. 8: bakery tray (Fig. 28:1), Inv. No. C-0524 [003]**Uncoated | Nile C₂ | W₂Rim sherd; everted direct rim. Rd: 28.00 cm 3/32; Wd: 1.90 cm; H₁: 2.93 + x cm; eroded.**Egyptian marls****Household ware****No. 9: juglet (Fig. 28:1), Inv. No. P7105A (Drawing No. 0629)**

Uncoated	Marl A ₄	W ₂	---	ox.	3
----------	---------------------	----------------	-----	-----	---

Body sherd; globular type. Md: 12.00 cm; Wd: 0.60 cm; H₁: 6.00 + x cm. Surface colour: 10YR 7/3 very pale brown self slip. Break: 7.5YR 6/4 light brown. Throwing lines inside and outside. Surface treatment: smoothed on the wheel.

No. 10: jar (Fig. 28:1), Inv. No. P7106A (Drawing No. 0629)

Uncoated	Marl A ₄	W ₂	---	ox.	3
----------	---------------------	----------------	-----	-----	---

Body sherd. Md: 14.50 + x cm; Wd: 0.5; H₁: 5.0 + x cm. Surface colour: 10YR 6/4 light yellowish brown self slip. Break: 7.5YR 6/4 light brown. Throwing lines inside and outside. Surface treatment: smoothed on the wheel.

No. 11: jar (Fig. 28:2), Inv. No. P1212A (Drawing No. 0629)

Uncoated	Marl A ₄	W ₂	---	ox.	3
----------	---------------------	----------------	-----	-----	---

Rim and neck fragment; long-necked jar. Rd: 6.00 cm 5/32; Nd: 5.00 cm; Wd: 0.30 cm; H₃: 2.00 + x cm. Surface colour: 10YR 7/3 very pale brown self slip. Break: 7.5YR 6/4 light brown. Throwing lines inside. Surface treatment: smoothed on the wheel.

No. 12: jar (Fig. 28:2), Inv. No. P1213A (Drawing No. 0521)

Uncoated	Marl A ₄	W ₂	---	ox.	3
----------	---------------------	----------------	-----	-----	---

Rim sherd; trimmed rim. Rd: 10.00 cm 3/32; Wd: 0.35 cm; H₁: 3.00 + x cm; H₃: 3.00 cm. Surface colour: 10YR 6/4 light yellowish brown self slip. Break: 10YR 6/3 pale yellow. Surface treatment: smoothed on the wheel.

No. 13: amphora, Inv. No. C-0524 (2)

Uncoated	Marl F + ochre	W ₂			
----------	----------------	----------------	--	--	--

Body sherd; Wd: 1.20 cm; very eroded.

Body sherds, Nile B₂: 16.20 dm²; Nile C₁; Marl A₄.

b) North Sinai/South Palestine pottery

Household ware

No. 14: amphora, II.TG 10, body sherds.

c) Imported pottery

Levantine household ware

No. 15: amphora, IV.TG 03, body sherds.

No. 16: amphora, IV.TG 52 (=TD IV.19 c.), body sherds.

No. 17: amphora, = TD IV.08, body sherds.

No. 18: amphora (Fig. 28:2), Inv. No. C-0463 [002]

Uncoated	= TD IV.08	W ₂			
----------	------------	----------------	--	--	--

Rim sherd; vertical direct rim. Rd: 12.00 cm 7/32; Wd: 0.90 cm; H₁: 3.47 + x cm; throwing lines inside; eroded.

Cypriote fine ware

No. 19: juglet (Fig. 28:2), Inv. No. P0737A (Drawing No. 0302)

WP	VI.?	Ha ₂	---	ox.	2-3
----	------	-----------------	-----	-----	-----

Handle fragment. Hd: 1.00 x 0.65 cm; oval in section; 1; single strap. Surface colour: 7.5YR 7/4 pink slip. Break: 7.5YR 7/4 pink. Surface treatment: polished, low lustre.

*Bichrome ware***No. 20: jug** (Fig. 28:2), Inv. No. P0748A (Drawing No. 1095)

WPBI	VI.TG 40	Ha ₂	---	ox.	3
------	----------	-----------------	-----	-----	---

Handle fragment. Hd: 1.70 x 1.80 cm; double strap. Surface colour: 2.5Y 8/2 pale yellow slip. Break: 2.5Y 8/2 pale yellow. Throwing lines inside; comb marks on surface. Decoration: horizontally and vertically painted bands, 10YR 3/1 very dark grey and 5YR 4/2 dark reddish grey. Surface treatment: polished, low lustre.

II.- Finds*Tool*

No. 21: hammer? (Fig. 28:2), Inv. No. F0902A (before Inv. No. F0902B. Drawing No. 1078). Complete; sandstone. Weight: 424.00 gr. 7.00 x 6.60 x 6.40 cm. Primary form: pebble by use.

L0250 = L0175 = L0280 (Fig. 29)**I.- Pottery****a) Egyptian pottery****Nile silt clay***Fine ware***No. 1: bowl** (Fig. 29:1), Inv. No. C-0488 [005]

RP	Nile B ₂	W ₂
----	---------------------	----------------

Rim sherd; incurved wall, inverted direct rim, round lip. Rd: 27.00 cm 1/16; Wd: 0.85 cm; throwing lines inside; red slip polished on the exterior surface.

*Household ware***No. 2: bowl** (Fig. 29:1), Inv. No. C-0488 [006]

Uncoated	Nile B ₂	W ₂
----------	---------------------	----------------

Rim sherd; everted direct rim, round lip. Rd: 24.00 cm 3/64; Wd: 0.70 cm; throwing lines inside; smoothed inside.

No. 3: bowl (Fig. 29:1), Inv. No. C-0670 [001]

Uncoated	Nile B ₂	W ₂
----------	---------------------	----------------

Rim sherd; everted articulated symmetrical rim. Rd: 23.00 cm 3/32; Wd: 0.80 cm; H₁: 3.00 + x cm; eroded.

No. 4: bowl (Fig. 29:1), Inv. No. C-0670 [002]

Uncoated	Nile C ₁	W ₂
----------	---------------------	----------------

Rim sherd; everted direct rim. Rd: 32.00 cm 1/16; Wd: 0.85 cm; H₁: 1.47 + x cm; eroded.

No. 5: jar (Fig. 29:1), Inv. No. C-0488 [004]

Uncoated	Nile B ₂	W ₂
----------	---------------------	----------------

Rim sherd; vertical direct rim, round lip. Rd: 10.00 cm 3/16; Wd: 0.70 cm; throwing lines inside; smoothed on the wheel.

No. 7: jar, Inv. No. C-0488 [007]

Uncoated	Nile B ₂	Ha ₂
----------	---------------------	-----------------

Handle fragment; attached vertical loop handle; Hd: 2.25 x 1.90 cm; irregular; 1; single strap; smoothed.

No. 8: storage jar (Fig. 29:1), Inv. No. C-0488 [002]

Uncoated	Nile B ₂	W ₂
----------	---------------------	----------------

Rim sherd; everted direct rim, round lip. Rd: 26.00 cm 3/32; Wd: 1.00 cm; throwing lines inside; smoothed on the wheel.

No. 9: storage jar (Fig. 29:1), Inv. No. C-0488 [003]

Uncoated	Nile B ₂	W ₂
----------	---------------------	----------------

Rim sherd; inverted articulated exterior, round lip. Rd: 34.00 cm 3/64; Wd: 1.00 cm; throwing lines inside; smoothed on the wheel.

No. 10: storage jar (Fig. 29:1), Inv. No. C-0488 [001]

Uncoated	Nile B ₂	W ₂
----------	---------------------	----------------

Rim sherd; inverted articulated interior, round lip. Rd: 26.00 cm 5/32; Wd: 0.80 cm; throwing lines inside; smoothed on the wheel.

No. 11: storage jar, Inv. No. C-0670 [003]

Uncoated	Nile B ₂	W ₂	W
----------	---------------------	----------------	---

Base fragment; round base; Wd: 1.10 cm; H₁: 3.10 + x cm; eroded.

Pottery with special functions

No. 12: tray (Fig. 29:1), Inv. No. C-0439 [001]

Uncoated	Nile C ₂	Ha ₁
----------	---------------------	-----------------

Fragment. D: ca. 44.00 cm; Wd: 1.90 cm; H₁: 7.00 cm; eroded.

No. 13: "pigeon" pot (Fig. 29:2), Inv. No. C-0488 [009]

Uncoated	Nile B ₂	W ₂	W
----------	---------------------	----------------	---

Base and wall fragment. Bd: 4.00 cm; Wd: 1.45 cm; a hole in the base; smoothed on the wheel.

Egyptian marls

Household ware

No. 14: juglet (Fig. 29:2), Inv. No. C-0439 [002]

Uncoated	Marl F	W ₂ + Ha ₂
----------	--------	----------------------------------

Rim and handle fragment; attached vertical loop handle; rim to body, everted direct rim, round lip. Rd: 3.00 cm 1/4; Wd: 0.35 cm; Hd: 1.55 x 0.90 cm, oval in section; 1; single strap; H₁: 2.30 + x cm. Eroded and salt incrustated. Another (handle), Hd: 0.90 x 0.90 cm.

Body sherds, Nile B₂: 4.00 dm²; Nile C₁: 0.70 dm²; Nile C₂: 1.40 dm²; Marl F.

b) Imported pottery

Levantine household ware

No. 15: amphora, Inv. No. C-0670 [004]

Uncoated	IV.TG 36	Ha ₂
----------	----------	-----------------

Handle fragment; Hd: 2.30 x 3.00 cm; single strap; smoothed. Body sherds.

No. 16: amphora, = TD IV.08, body sherds: 0.10 dm².

No. 17: amphora, similar to TD IV.08, body sherds: 0.10 dm².

Cypriote household ware

No. 18: amphora, Inv. No. C-0488, VI.TG 40, body sherd.

II.- Finds**Tools**

No. 19: sharpener (Fig. 29:2), Inv. F0584A (Drawing No. 1075). Complete; pumice. Weight: 23 grs. 4.70 x 5.90 x 1.70 cm Wear type: friction; wear marks: grooves. Stroke: indeterminate.

No. 20: sharpener, Inv. F0900A (before Inv. No. F900B. Drawing No. 0900). Complete; pumice. 5.80 x 4.90 x 1.50 cm. Primary form: cobble. Manufacture technique: by use. Wear type: friction; wear marks: a groove of sharpening. Surfaces: 2. Contact: opposite. Surface texture: coarse.

Objects of unknown use

No. 21: fragment of an object, Inv. No. F0311A. Lead. 1.10 x 1.80 x 5.50 cm. A net weight for fishing? Find No. 007.

No. 22: fragment of an object, Inv. No. F0310A. Lead. 1.60 x 1.70 cm. A net weight for fishing? Find No. 008.

No. 23: fragment of an object, Inv. No. F1052A. Bronze. destroyed.

L0271 = L0283 = L0060 (Fig. 30)**I.- Pottery****a) Egyptian pottery****Nile silt clay****Household ware**

No. 1: bowl (Fig. 30:1), Inv. No. C-0417 [047]

Uncoated	Nile B ₂	W ₂
----------	---------------------	----------------

Rim sherd, inverted articulated symmetrical rim, trimmed lip. Rd: 20.00 cm 1/16; Wd: 0.70 cm; H₁: 3.20 + x cm. Throwing lines outside; smoothed on the wheel.

No. 2: bowl (Fig. 30:1), Inv. No. C-0417 [046]

Uncoated	Nile B ₂	W ₂
----------	---------------------	----------------

Rim sherd, inverted direct rim. Rd: 20.00 cm 3/32; Wd: 0.80 cm; H₁: 3.40 + x cm. Throwing lines outside; smoothed on the wheel. Another, Rd: 22.00 cm 1/8.

No. 3: bowl (Fig. 30:1), Inv. No. C-0417 [052]

Uncoated	Nile B ₂	W ₂
----------	---------------------	----------------

Rim sherd, everted direct rim. Rd: 26.00 cm 1/16; Wd: 0.65 cm; H₁: 2.10 + x cm. Throwing lines outside; smoothed on the wheel. Others, Rd: 18.00 cm 1/1, Rd: 20.00 cm 1/4; Rd: 22.00 cm 1/16; Rd: 26.00 cm 1/1, Rd: 28.00 cm 1/16; Rd: 32.00 cm 1/16.

No. 4: bowl (Fig. 30:1), Inv. No. C-0417 [032]

Uncoated	Nile B ₂	W ₂
----------	---------------------	----------------

Rim sherd, everted articulated exterior rim, round lip. Rd: 26.00 cm 5/32; Wd: 1.00 cm; H₁: 5.50 + x cm. Throwing lines outside; smoothed on the wheel.

No. 5: bowl (Fig. 30:1), Inv. No. C-0417 [033]

Uncoated	Nile B ₂	W ₂
----------	---------------------	----------------

Rim sherd, everted articulated exterior rim, modelled lip. Rd: 26.00 cm 5/32; Wd: 1.05 cm; H₁: 5.50 + x cm. Throwing lines outside; smoothed on the wheel.

No. 6: bowl (Fig. 30:1), Inv. No. C-0417 [031]

Uncoated	Nile C ₁	W ₂
----------	---------------------	----------------

Rim sherd, everted articulated exterior rim, pendant lip. Rd: 24.00 cm 1/16; Wd: 0.80 cm; H₁: 4.90 + x cm. Throwing lines outside; smoothed on the wheel. Another, Rd: 26.00 cm 3/32.

No. 7: bowl (Fig. 30:1), Inv. No. C-0417 [051]

Uncoated	Nile B ₂	W ₂
----------	---------------------	----------------

Rim sherd, everted articulated interior rim, modelled lip. Rd: 42.00 cm 1/8; Wd: 1.00 cm; H₁: 4.60 + x cm. Throwing lines outside; smoothed on the wheel. Others, Rd: 42.00 cm 3/32; Rd: 20.00 cm 1/32.

No. 8: bowl? (Fig. 30:1), Inv. No. C-0417 [025]

Uncoated	Nile B ₂	W ₂
----------	---------------------	----------------

Rim sherd, everted articulated symmetrical rim, trimmed lip. Rd: 24.00 cm 1/8; Wd: 0.90 cm; H₁: 6.00 + x cm. Throwing lines outside; smoothed on the wheel.

No. 9: bowl (Fig. 30:1), Inv. No. C-0456 [004]

Uncoated	Nile B ₂	W ₂
----------	---------------------	----------------

Rim sherd; everted articulated exterior rim, modelled lip. Rd: 24.00 cm 1/16; Wd: 0.70 cm; H₁: 2.30 + x cm. Throwing lines outside; smoothed on the wheel.

No. 10: bowl, Inv. No. C-0417 [074]

Uncoated	Nile B ₂	base finished on the wheel
----------	---------------------	----------------------------

Base fragment; ring base [R₃]. Bd: 5.00 cm 1/4; Wd: 0.85 cm; H₁: 2.40 + x cm, Base finished on the wheel; Throwing lines inside and outside; smoothed on the wheel. Another, 1/1.

No. 11: cup (Fig. 30:1), Inv. No. C-0417 [087]

Uncoated	Nile B ₂	W ₂
----------	---------------------	----------------

Rim sherd, inverted articulated interior rim, trimmed lip. Rd: 8.00 cm 3/32; Wd: 0.30 cm; H₁: 1.90 + x cm. Throwing lines inside; smoothed on the wheel.

No. 12: cup (Fig. 30:1), Inv. No. C-0417 [085]

Uncoated	Nile B ₂	W ₂
----------	---------------------	----------------

Rim sherd, vertical direct rim. Rd: 8.00 cm 3/32; Wd: 0.50 cm; H₁: 1.60 + x cm. Throwing lines inside; smoothed on the wheel. Another, Rd: 6.00 cm 3/32.

No. 13: jar (Fig. 30:2), Inv. No. C-0417 [015]

Uncoated	Nile B ₂	W ₂
----------	---------------------	----------------

Rim sherd, inverted direct rim. Rd: 14.00 cm 3/32; Wd: 0.60-1.00 cm; H₁: 3.80 + x cm. Throwing lines inside; smoothed on the wheel.

No. 14: jar (Fig. 30:2), Inv. No. C-0417 [029]

Uncoated	Nile B ₂	W ₂
----------	---------------------	----------------

Rim sherd, inverted articulated exterior rim, round lip. Rd: 10.00 cm 1/8; Wd: 0.68 cm; H₁: 2.90 + x cm. Throwing lines inside; smoothed on the wheel.

No. 15: jar (Fig. 30:2), Inv. No. C-0417 [008]

Uncoated	Nile C ₁	W ₂
----------	---------------------	----------------

Rim sherd, vertical direct rim. Rd: 14.00 cm 3/32; Wd: 0.60 cm; H₁: 4.70 + x cm. Ridges inside; smoothed on the wheel. Another, Rd: 10.00 cm 1/8, Rd: 12.00 cm 3/8.

No. 16: jar (Fig. 30:2), Inv. No. C-0417 [012]

Uncoated	Nile B ₂	W ₂
----------	---------------------	----------------

Rim sherd, vertical direct rim. Rd: 10.00 cm 5/32; Wd: 0.60 cm; H₁: 2.60 + x cm. Throwing lines inside; smoothed on the wheel. Others, Rd: 8.00 cm 3/32, Rd: 10.00 cm 1/1, Rd: 12.00 cm 1/4, Rd: 16.00 cm 3/32.

No. 17: jar (Fig. 30:2), Inv. No. P0759A (Drawing No. 0306)

Uncoated	Nile B ₂	W ₂	med.	ox.	2
----------	---------------------	----------------	------	-----	---

Incomplete, fragmentary; everted direct rim; globular type; no base preserved. Rd: 10.00 cm 1/2; Nd: 9.50 cm; Md: 16.50 cm; Wd: 0.50 cm; H₁: 17.00 + x cm; H₂: 4.00 + x cm. Surface colour: 2.5YR 5/4 reddish brown. Break: 2.5YR 5/4 reddish brown. Technical details: throwing lines inside. Surface treatment: smoothed on the wheel. Others (rim), Rd: 12.00 cm 1/16, Rd: 14.00 cm 1/16.

No. 18: jar (Fig. 30:2), Inv. No. C-0417 [010]

Uncoated	Nile C ₁	W ₂
----------	---------------------	----------------

Rim sherd, everted direct rim, round. Rd: 10.00 cm 3/32; Wd: 0.30- 0.50 cm; H₁: 2.90 + x cm. Throwing lines inside; smoothed on the wheel.

No. 19: jar (Fig. 30:2), Inv. No. P1304A (Drawing No. 0651)

Uncoated	Nile C ₁	W ₂ + Ha ₂	---	ox.	2
----------	---------------------	----------------------------------	-----	-----	---

Rim, handle and shoulder fragment; everted articulated symmetrical rim. Rd: 16.00 cm 1/4; Md: 22.00 cm 3/16; Wd: 1.00 cm; H₁: 6.70 + x cm; Hd: 3.00 x 2.60 cm; single strap. Surface colour: 2.5YR 5/8 red. Break: 2.5YR 4/8 red. Throwing lines inside; vertical loop handles applied from shoulder to lip. Eroded handle.

No. 20: jar, Inv. No. C-0417 [076]

Uncoated	Nile B ₂	W ₂	base finished on the wheel
----------	---------------------	----------------	----------------------------

Base fragment, pointed base. Wd: 1.00 cm; throwing lines outside; smoothed on the wheel. Others, 5 bases.

No. 21: jar, Inv. No. C-0417 [081]

Uncoated	Nile B ₂	W ₂	W
----------	---------------------	----------------	---

Base fragment, round base. Wd: 0.50 cm; throwing lines outside; smoothed on the wheel. Others, 3 bases.

No. 22: storage jar (Fig. 30:3), Inv. No. C-0417 [028]

Uncoated	Nile B ₂	W ₂
----------	---------------------	----------------

Rim sherd; inverted articulated rim, folded lip. Rd: 40.00 cm 1/16; Wd: 0.90 cm; H₁: 3.00 + x cm; smoothed on the wheel.

No. 23: storage jar (Fig. 30:3), Inv. No. C-0417 [026]

Uncoated	Nile B ₂	W ₂
----------	---------------------	----------------

Rim sherd; inverted articulated symmetrical rim, round. Rd: 22.00 cm 3/32; Wd: 0.90 cm; H₁: 4.40 + x cm. Throwing lines inside; smoothed on the wheel.

No. 24: storage jar (Fig. 30:3), Inv. No. C-0417 [024]

Uncoated	Nile C ₁	W ₂
----------	---------------------	----------------

Rim sherd; vertical direct rim. Rd: 30.00 cm 3/32; Wd: 0.80 cm; H₁: 5.60 + x cm. Throwing lines inside; smoothed on the wheel.

Pottery with special function**No. 25: lid** (Fig. 30:3), Inv. No. C-0417 [062]Uncoated | Nile B₂ | W₂

Rim sherd; everted direct rim. Rd: 28.00 cm 5/32. Wd: 0.80 cm; H₁: 6.00 + x cm; throwing lines outside; smoothed on the wheel; smoked. Others, Rd: 18.00 cm 1/16, 20.00 cm 3/32, Rd: 20.00 cm 1/16, Rd: 22.00 cm 3/32, Rd: 22.00 cm 1/16, Rd: 24.00 cm 1/8, Rd: 24.00 cm 1/8, Rd: 26.00 cm 3/32, Rd: 26.00 cm 1/16.

No. 26: bakery tray (Fig. 30:3), Inv. No. P1301A (Drawing No. 0650)Uncoated | Nile C₂ | W₁ | Ha | ox. | 2

Complete, fragmentary; everted rim. Rd: 24.00 cm 1/8; Bd: 22.00 cm 1/8; Wd: 1.10 cm; H₁: 2.40 cm. VI: 1000. Surface colour: 2.5YR 5/4 reddish brown. Break: 10R 5/8 red. Surface treatment: uneven.

No. 27: bakery tray (Fig. 30:3), Inv. No. P1300A (Drawing No. 0649)Uncoated | Nile C₂ | W₁ | Ha | ox. | 2

Complete, fragmentary; everted direct rim. Rd: 24.00 cm 1/8; Bd: 22.00 cm 1/8; H₁: 2.40 cm. VI: 1000. Surface colour: 10R 5/6 red. Break: 10R 4/6 red. Eroded.

No. 28: bakery tray (Fig. 30:3), Inv. No. P01302A (Drawing No. 0650)Uncoated | Nile C₂ | W₁ | Ha | ox. | 2

Complete, fragmentary; base and rim fragment; everted direct rim. Rd: 24.00 cm 5/32; Bd: 22.00 cm 5/32; Wd: 1.40-1.90 cm; H₁: 4.70 cm. VI: 511. Surface colour: 2.5YR 6/4 light reddish brown. Break: 10R 4/6 red. Eroded. Another, Rd: 26.00 cm 1/16, Nile B₂.

Egyptian marls**Household ware****No. 29: bowl**, Inv. No. C-0417 [086]Uncoated | Marl A₄ | W₂

Rim sherd; everted articulated symmetrical rim, trimmed lip. Rd: 16.00 cm 1/16; Wd: 0.40 cm; throwing lines outside; smoothed on the wheel; eroded.

No. 30: bowl (Fig. 30:4), Inv. No. P0833A (Drawing No. 0527)Uncoated | Marl A₄ c. | W₂ | --- | ox. | 3

Body and rim fragment; carinated bowl with articulated interior lip. Rd: 16.00 cm 3/32; Wd: 0.40 cm; H₁: 1.50 + x cm. Surface colour: 2.5Y 7/3 pale yellow; self slip. Break: 2.5Y 7/3 pale yellow. Surface treatment: smoothed on the wheel.

No. 31: goblet or cup? (Fig. 30:4), Inv. No. P1245A (Drawing No. 0529)Uncoated | Marl A₄ | W₂ | --- | ox. | 3

Rim and body sherd; everted direct rim. Rd: 6.00 cm 1/32; Wd: 0.25 cm. Surface colour: 2.5YR 7/2 light grey. Break: 7.5YR 7/4 pink. Rilling lines inside and outside. Surface treatment: smoothed on the wheel.

No. 32: cup, Inv. No. P1152A (Drawing No. 0638)Uncoated | Marl A₄ c. | W₂ | --- | ox. | 2-3

Body sherd. Md: 6.00 + x cm; Wd: 0.35 cm; H₁: 3.00 + x cm. Surface colour: 2.5Y 8/3 pale yellow. Break: 10YR 7/3 very pale yellow. Throwing lines inside. Surface treatment: smoothed on the wheel.

No. 33: jar (Fig. 30:4), Inv. No. P0832A (Drawing No. 0522)

Uncoated	Marl A ₄	W ₂	---	ox.	3
----------	---------------------	----------------	-----	-----	---

Rim, neck and shoulder fragment; inverted rim, articulated exterior lip. Rd: 7.00 cm 3/16; Nd: 7.00-8.00 cm; Md: 10.50 cm; Wd: 0.30 cm; H₁: 3.50 + x cm. Surface colour: 10YR 7/3 very pale brown interior; 10YR 7/2 light grey exterior; self slip. Break: 2.5YR 5/4 reddish brown. Rilling lines inside and outside. Surface treatment: smoothed on the wheel.

No. 34: jar (Fig. 30:4), Inv. No. P0834A (Drawing No. 0530)

Uncoated	Marl A ₄	W ₂	---	ox.	3
----------	---------------------	----------------	-----	-----	---

Rim and neck sherd; slightly inverted rim, articulated exterior lip. Rd: 6.00 cm 3/32; Wd: 0.30 cm; H₃: 1.60 + x cm. Surface colour: 10YR 6/3 pale brown; self slip. Break: 10YR 6/3 pale brown. Surface treatment: smoothed on the wheel.

No. 35: jar (Fig. 30:4), Inv. No. P0825A (Drawing No. 0632)

Uncoated	Marl A ₄	W ₂	---	ox.	3
----------	---------------------	----------------	-----	-----	---

Rim sherd; vertical direct rim. Rd: 10.10 cm 1/16; Wd: 2.00 cm; H₁: 2.20 + x cm. Surface colour: 2.5YR 7/2 light grey self slip. Break: 2.5YR 8/3 pale yellow. Rilling lines inside. Surface treatment: smoothed on the wheel.

No. 36: jar (Fig. 30:4), Inv. No. P1297A (Drawing No. 0705)

Uncoated	Marl A ₄	W ₂	---	ox.	3
----------	---------------------	----------------	-----	-----	---

Rim sherd; vertical direct rim, articulated exterior lip. Rd: 10.00 cm 1/4; Wd: 0.60 cm; H₁: 3.00 + x cm. Surface colour: 5YR 6/8 reddish yellow. Break: 5YR 5/6 yellowish red. Throwing lines inside. Surface treatment: smoothed on the wheel.

No. 37: jar (Fig. 30:4), Inv. No. P0826A (Drawing No. 0631)

Uncoated	Marl A ₄	W ₂	---	ox.	3
----------	---------------------	----------------	-----	-----	---

Rim sherd; articulated exterior lip, rounded, and incurved walls. Rd: 8.00 cm 1/1; Wd: 0.25 cm; H₁: 1.50 + x cm. Surface colour: 2.5YR 7/2 light grey; self slip. Break: 2.5YR 7/3 pale brown. Rilling lines inside. Surface treatment: smoothed on the wheel.

No. 38: jar (Fig. 30:5), Inv. No. P1151A (Drawing No. 0635)

Uncoated	Marl A ₄ c.	W ₂	---	ox.	2-3
----------	------------------------	----------------	-----	-----	-----

Rim sherd; inverted articulated exterior rim. Rd: 6.00 cm 1/8; Md: 7.00 + x cm; Wd: 0.30 cm; H₁: 2.00 + x cm. Surface colour: 2.5YR 7/3 pale yellow. Break: 10YR 7/3 very pale yellow. Throwing lines inside. Surface treatment: smoothed on the wheel.

No. 39: amphora (Fig. 30:5), Inv. No. P7011A (Drawing No. 0903)

Uncoated	Marl F	Ha ₂ + W ₂	---	ox.	3
----------	--------	----------------------------------	-----	-----	---

Handle and body sherd; single strap. Md: ca. 27.00 cm; Wd: 0.65 cm; H₁: 10.00 + x cm; Hd: 3.00 x 1.65 cm. Surface colour: 7.5YR 6/4 light brown self slip. Break: 10YR 6/3 pale brown core; 5YR 6/6 reddish yellow-5/6 yellowish red oxidation zones. Throwing lines inside and outside. Surface treatment: smoothed on the wheel.

Body sherds: Nile B₂: 36.40 dm²; Nile C₁: 3.50 dm²; Nile C₂: 3.50 dm²; Nile E₂: 0.10 dm²; Marl A₂: 0.20 dm²; Marl F: 0.30 dm².

b) North Sinai/South Palestine pottery

Household ware

No. 40: amphora (Fig. 30:5), Inv. No. P1290A (Drawing No. 0710)

Uncoated	II.TG 14	W ₂	---	ox.	3
----------	----------	----------------	-----	-----	---

Rim, neck and shoulder fragment; vertical direct rim. Rd: 10.00 cm 3/4; Wd: 0.50 cm; H₁:

3.70 + x cm. Surface colour: 5YR 7/4 pink self slip. Break: 5YR 6/3 light reddish brown core; 2.5YR 6/6 light red oxidation ones. Throwing lines inside. Surface treatment: smoothed on the wheel.

c) Imported pottery

Levantine fine ware

No. 41: juglet (Fig. 30:5), Inv. No. P1285A (Drawing No. 0714)

BP	IV.TG 11 v.f.	W ₂	---	ox.	3
----	---------------	----------------	-----	-----	---

Shoulder sherd. Md: 10.20 + x cm 7/32; Wd: 0.70 cm; H₁: 3.20 + x cm. Surface colour: 10YR 8/3 very pale brown slip. Break: 7.5YR 6/4 light brown core; 7.5YR 3/1 very dark grey and 10YR 8/3 very pale brown oxidation zones. Throwing lines inside; scraping marks inside produced by a stick to open the neck. Surface treatment: polished, low lustre. Smoked on the shoulder.

Levantine household ware

No. 42: amphora (Fig. 30:5), Inv. No. P2029A (Drawing No. 0458)

Uncoated	IV.TG 24	W ₂	---	me.	3
----------	----------	----------------	-----	-----	---

Shoulder fragment; "torpedo" type, flat shoulder. Md: 23.00 cm; Wd: 0.80 cm; H₁: 7.00 + x cm; H₂: 2.00 cm. Surface colour: 5YR 6/6 reddish yellow. Break: 5YR 7/8 reddish yellow interior and 5 YR 6/1 grey exterior. Technical details: throwing lines inside. Surface treatment: smoothed on the wheel.

No. 43: amphora, IV.TG 03, body sherds: 0.10 dm².

No. 44: amphora, IV.TG 18, body sherds: 0.30 dm².

No. 45: amphora, IV.TG 22 = IV, Phoen.04?, body sherds: 0.10 dm².

No. 46: amphora, IV.TG 23, body sherds: 0.10 dm².

No. 47: amphora, IV.TG 51 (= TD IV.19), body sherds: 0.30 dm².

No. 48: amphora, = TD IV.02, body sherds: 0.10 dm².

No. 49: amphora (Fig. 30:6), Inv. No. P1298A (Drawing No. 0705)

Uncoated	= TD IV.02	W ₂	---	ox.	3
----------	------------	----------------	-----	-----	---

Rim sherd; everted direct rim. Rd: 10.00 cm 1/8; Wd: 0.80 cm; H₁: 1.90 + x cm. Surface colour: 5YR 7/6 reddish yellow. Break: 5YR 6/6 reddish yellow. Surface treatment: smoothed on the wheel.

No. 50: amphora, = TD IV.08, body sherds: 0.20 dm².

No. 51: amphora, similar to TD IV.08, body sherds: 0.20 dm².

Phoenician fine ware

No. 52: jar? (Fig. 30:6), Inv. No. P1244A (Drawing No. 0524)

RP	IV.TG 35 = IV.Phoen.01	W ₂	---	ox.	3
----	------------------------	----------------	-----	-----	---

Three body sherds. Md: 13.50 + x cm; Wd: 0.45-0.50 cm. Surface colour: 7.5YR 7/4 pink; 10R 4/6 red slip. Break: 7.5YR 6/6 reddish yellow. Technical details: throwing lines inside. Surface treatment: polished, low lustre.

Cypriote fine ware

No. 53: pilgrim flask, Inv. No. P7001A (Drawing No. 0900)

BP	VI.TG 04	Ha ₂ + W ₂	---	ox.	3
----	----------	----------------------------------	-----	-----	---

Handle fragment and body sherd. Md: ca. 4.00 cm; Wd: 0.30 cm; Hd: 0.90 x 0.50 cm; H₁: 1.60 + x cm. Surface colour: 7.5YR 7/3 pink-6/3 light brown slip. Break: 7.5YR 5/4 brown. Technical details: body made in two halves which are then joined. Surface

treatment: polished.

Aegean fine ware

Black-on-Red ware

No. 54: juglet (Fig. 30:6), Inv. No. P1266A (Drawing No. 0703)

RPMO	VII.TG 45	W ₂	---	ox.	3
------	-----------	----------------	-----	-----	---

Body sherd. Md: ca. 8.00 cm; Wd: 0.40 cm; H₁: 1.50 + x cm. Surface colour: 2.5YR 5/6 red slip. Break: 2.5YR 5/6 red. Technical details: throwing lines inside. Decoration: a painted circle, 1 mm wide, 5YR 2.5/1 black. Surface treatment: polished, low lustre.

No. 55: juglet, Inv. No. P1267A

RPMO	VII.TG 45	W ₂	---	ox.	3
------	-----------	----------------	-----	-----	---

Body sherd. Md: ca. 5.00 cm; Wd: 0.45 cm; H₁: 2.00 + x cm. Surface colour: 2.5YR 4/8 red slip. Break: 2.5YR 5/8 red. Technical details: throwing lines inside. Decoration: painted lines, 1 mm wide, 2.5YR 3/3 dark reddish brown. Surface treatment: polished, low lustre.

Black-on-Red I (III) ware

No. 56: juglet?, Inv. No. P0813A

RPMO	VII.TG 45	W ₂	---	ox.	3
------	-----------	----------------	-----	-----	---

Body sherd. Md: 9.00 cm 1/16; Wd: 0.30 cm; H₁: 2.60 + x cm. Surface colour: 2.5YR 3/4 dark reddish brown slip. Break: 5YR 6/6 reddish yellow. Technical details: throwing lines inside. Decoration: two painted lines, 1 mm wide, 5YR 2.5/1 black. Surface treatment: polished, medium lustre.

Black-on-Red III (V) ware

No. 57: juglet (Fig. 30:6), Inv. No. P0506A (Drawing No. 0233)

RPMO	VII.TG 39	W ₂	---	ox.	3
------	-----------	----------------	-----	-----	---

Rim sherd; everted direct rim. Rd: 3.90 cm; Wd: 0.20 cm; H₁: 0.60 + x cm. Surface colour: 5YR 6/4 light reddish brown slip. Break: 5YR 6/6 reddish yellow. Technical details: throwing lines inside. Decoration: a painted band, 3 mm wide, on the rim inside, 5YR 4/2 dark reddish grey.

Aegean household ware

No. 58: amphora (Fig. 30:6), Inv. No. P1195A (Drawing No. 0705)

Uncoated	≈ VII.TG 46 (Chian)	W ₂	---	ox.	3
----------	---------------------	----------------	-----	-----	---

Rim sherd; vertical direct rim. Rd: 11.00 cm 3/32; Wd: 0.50 cm; H₁: 2.80 + x cm. Surface colour: 7.5YR 7/4 pink. Break: 2.5YR 5/6 red. Technical details: throwing lines inside. Surface treatment: smoothed on the wheel.

No. 59: amphora, VII.TG 45, body sherds: 0.20 dm².

II.- Finds

Religion, amulets

No. 60: wdjat?, Inv. No. F0554A. Fragmentary; faience; moulded. 1.10 x 0.90 x 0.30 cm; colour: 10YR 7/2 light grey; darker parts: 7.5YR 3/4 dark brown. *Find No. 013.*

No. 61: deity figurine (Sekhmet?), Inv. No. F0533A. Fragmentary; faience; moulded. 1.00 x 0.50 x 0.40 cm; colour: 10YR 8/2 very pale brown. Description: the head and the feet are missing. Function: amulet. *Find No. 009.*

No. 62: Hathor figurine (Plate 11), Inv. No. F0486 (Drawing No. 0275). Fragmentary, mended; faience; moulded. 2.10 x 1.60 x 0.80-0.40 cm; colour: 2.5Y 8/1 white. Only the

crown was preserved, a feather crown framed by the horns and the sun disc; dorsal pillar; perforation: 1 mm. Function: amulet. SCA No. 2035. *Find No. 001.*

No. 63: amulet? (Fig. 30:6), Inv. No. F0488A (Drawing No. 0641). Fragmentary, eroded; faience. 1.50 x 0.60 cm; colour: 10YR 8/2 very pale brown; the upper part of a statuette? *Find No. 003.*

No. 64: figurine amulet?, Inv. No. F0490A. Fragmentary; faience; moulded. 0.90 x 0.300 x 0.20 cm. Colour: 2.5Y 8/4 pink; part of the neck?; bad preserved. *Find No. 005.*

No. 65: unengraved plaque?, Inv. No. F0579A. Complete; limestone. 8.30 x 7.90 x 2-30 cm.

Figurative art

No. 66: terracotta zoomorphic figurine (Fig. 30:7), Inv. No. F0459 (Drawing No. 0268). Fragmentary; clay; hand-made. 2.20 x 2.90-1.50 x 1.50 cm. Colour: 5YR 5/4 (reddish brown)- 6/3 (light reddish brown). Head of an animal (a jackal?); the right ear is lacking. SCA No. 2022. *Find No. 024.*

No. 67: terracotta zoomorphic figurine? (Fig. 30:7), Inv. No. F0472A (Drawing No. 0653). Fragmentary; clay; hand-made. 3.20 x 3.10-1.80 x 2.30 cm; colour: 5YR 5/4 reddish brown and 6/4 light reddish brown. *Find No. 031.*

Personal objects

No. 68: bead, Inv. No. F0364A; fragmentary; faience. *Find No. 16.*

No. 69: bead, Inv. No. F0429A; faience; destroyed. *Find No. 025.*

No. 70: bead, Inv. No. F0489A; faience; destroyed. *Find No. 004.*

No. 71: bead, Inv. No. F0529A. Fragmentary, 1/2 preserved; faience; moulded. 1.80 x 0.70 cm Colour: 10YR 7/2 light grey and 10YR 3/3 dark brown; horizontal perforation (parallel to the direction face-back). *Find No. 016.*

No. 72: bead, Inv. No. F0531A (Drawing No 0622). Complete; faience; moulded. 0.20 x 0.20 x 0.20 cm; colour: blue; cylindrical shape. *Find No. 012.*

No. 73: bead, Inv. No. F0552A. Faience; destroyed. *Find No. 018.*

Tools

Grinding stones

No. 74: netherstone (Fig. 30:7), Inv. No. F0503A (Drawing No. 0278). Composed; complete; quartzite?; white colour. Weight: 862.00 gr. 8.90 x 1.60 x 4.00 cm. Used surface: 4.10 x 3.50 cm. Primary form: pebble. Manufacture technique: pecked and ground to shape. Characteristics: slightly modified. Secondary use: hand. Degree of wear: 2-Medium. Wear type: abrasion; wear marks: fine striations. Surfaces: 2. Contact: opposite. Surface configuration: concave-flat. Stroke: circular.

No. 75: polisher (Fig. 30:7), Inv. No. F0905A (before F0905B. Drawing No. 0903). Complete; flattened pebble. Weight: 27.00 gr. 3.80 x 3.30 x 1.30 cm. Degree of wear: 2-Medium. Surfaces: 2. Contact: opposite.

Weight

No. 76: net weight, Inv. No. F1036A; fragmentary; lead.

Suspended weight

No. 77: loom weight (Fig. 30:7), Inv. No. F0328 (Drawing No. 0288). Complete; limestone. 3.80 x 4.30 x 3.10 cm; colour: white. Characteristic: frontal view shape: geometric-conical; side view shape: double concave. Vertical perforation (8 mm) in the middle of the body; cylindrical shape; a groove 1.5 mm wide. SCA No. 2022. *Find No. 008.*

Objects of unknown use

No. 78: unengraved stela? (Fig. 30:8), Inv. No. F0579A (Drawing No. 1072) Complete; limestone. 8.30 x 7.90 x 2.30 cm; colour: white.

No. 79: fragment of an object (Fig. 30:8), Inv. No. F0326A (Drawing No. 0640). Iron; melted. 4.00 x 0.60 x 0.60 cm. *Find No. 007.*

No. 80: fragment of an object, Inv. No. F0321A. Bronze. 0.80 x 0.90 cm. *Find No. 006.*

No. 81: fragment of an object, Inv. No. F0430A. Faience; moulded. 1.10 x 0.90 x 0.40 cm; colour: Chart 1 for gley 10Y 8/1 light greenish grey. *Find No. 028.*

No. 82: fragment of an object, Inv. No. F0445A. Granite. 1.10 x 1.80 x 0.60 cm; colour 10G 2.5/1 greenish black; cylindrical shape. *Find No. 030.*

No. 83: fragment of an object, Inv. No. F0457A. Faience; destroyed. *Find No. 026.*

No. 84: fragments (2) of an object, Inv. No. F0754A. Bronze; melted. 1) 0.89 x 0.63 x 0.50 cm; 2) 0.62 x 0.53 x 0.42 cm. *Find No. 014.*

No. 85: fragments (3) of an object, Inv. No. F0762A. Bronze. 1) 1.20 x 0.40 cm; 2) 0.70 x 0.50 cm; 3) 0.60 x 0.30 cm; parts of a ring? *Find No. 002.*

No. 86: fragments (3) of an object, Inv. No. F0766A. Bronze. 1.30 x 0.90 x 0.61 cm. *Find No. 013.*

No. 87: fragment of an object, Inv. No. F0788A. Bronze. 1.70 x 0.92 x 0.50 cm. *Find No. 003.*

Product

No. 88: faience slag, Inv. No. F0433A.

Raw material

No. 89: alabaster fragment, Inv. No. F0833A. 1.60 x 0.30 x 1.40 cm; triangular shape; used for inlaid decoration?

L0294 (Fig. 31)**I.- Pottery****a) Egyptian pottery****Nile silt clay****Household ware**

No. 1: bowl (Fig. 31:1), Inv. No. C-0506 [003]

Uncoated	Nile C ₁	W ₂
----------	---------------------	----------------

Rim sherd; everted direct rim, round lip. Rd: 20.00 cm 1/16; Wd: 0.60 cm; H₁: 2.00 + x cm; smoothed on the wheel. Another, Nile B₂, Rd: 24.00 cm 3/32.

No. 2: bowl (Fig. 31:1), Inv. No. C-0506 [011]

Uncoated	Nile B ₂	W ₂
----------	---------------------	----------------

Rim sherd; everted articulated exterior rim, round lip. Rd: 20.00 cm 3/32; Wd: 0.65 cm; H₁: 2.40 + x cm; eroded.

No. 3: bowl (Fig. 31:1), Inv. No. C-0506 [004]

Uncoated	Nile B ₂	W ₂
----------	---------------------	----------------

Rim sherd; everted articulated interior rim, round lip. Rd: 14.00 cm 1/16; Wd: 0.40 cm; H₁: 3.00 + x cm; eroded.

No. 4: jar (Fig. 31:1), Inv. No. C-0506 [009]

Uncoated	Nile C ₁	W ₂
----------	---------------------	----------------

Rim sherd; inverted direct rim. Rd: 10.00? cm 1/16; Wd: 0.60 cm; H₁: 2.90 + x cm;

smoothed on the wheel.

No. 5: jar (Fig. 31:1), Inv. No. C-0506 [008]

Uncoated Nile C₁ W₂

Rim sherd; inverted articulated exterior rim. Rd: 14.00 cm 3/32; Wd: 0.45-0.55 cm; H₁: 2.30 + x cm; smoothed on the wheel.

No. 6: jar (Fig. 31:1), Inv. No. C-0506 [005]

Uncoated Nile C₁ W₂

Rim sherd; vertical direct rim. Rd: 8.00 cm 3/16; Wd: 0.65 cm; H₁: 3.90 + x cm; eroded; smoked on the rim.

No. 7: jar (Fig. 31:1), Inv. No. C-0506 [013]

Uncoated Nile B₂ W₂

Rim sherd; vertical articulated exterior rim, rounded rim. Rd: 11.00 cm 3/32; Wd: 0.60 cm; H₁: 2.60 + x cm; eroded; smoked on the rim.

No. 8: jar, Inv. No. C-0506 (4) [001]

Uncoated Nile B₂ W₂

Rim sherd; everted direct rim. Wd: 0.60 cm; eroded.

No. 9: jar, Inv. No. C-0506 [019]

Uncoated Nile C₂ W₂ base finished on the wheel

Base and wall fragment; pointed base. Wd: 0.80 cm; H₁: 6.30 + x cm; throwing lines outside; fingerprints inside; smoothed on the wheel.

No. 10: storage jar (Fig. 31:1), Inv. No. C-0506 [001]

Uncoated Nile B₂ W₂

Rim sherd; vertical articulated exterior rim, rolled lip. Rd: 22.00 cm 1/8; Wd: 0.95 cm; H₁: 4.70 + x cm; eroded.

No. 11: storage jar (Fig. 31:1), Inv. No. C-0506 [002]

Uncoated Nile B₂ coarse W₂

Rim sherd; everted direct rim, round lip. Rd: 20.00 cm 1/16; Wd: 0.80 cm; H₁: 3.30 + x cm; eroded.

Egyptian marls

Household ware

No. 12: jar, Inv. No. C-0506 [006]

Uncoated Marl F Ha₂

Handle fragment; vertical loop handle. Hd: 1.10 x 2.40 cm, 1 strap; eroded.

Body sherds, Nile B₂: 17.40 dm².; Nile C₂: 10.00 dm².

b) Imported pottery

Levantine household ware

No. 13: amphora, Inv. No. C-0506 [015]

Uncoated IV.TG 23 W₂

Rim sherd; inverted articulated exterior rim, rounded lip. Rd: 10.00 cm 1/8; Wd: 0.85 cm; H₁: 4.00 + x cm; throwing lines inside; smoothed on the wheel.

No. 14: amphora, Inv. No. C-0506 [018]

Uncoated	= TD IV.08	Ha ₂
----------	------------	-----------------

Handle fragment; vertical loop handle. Hd: 3.00 x 1.30 cm, 1 strap.

II.- Finds

Tool

No. 15: grinding stone (Fig. 31:2), Inv. No. F0505A (Drawing No. 0280). Complete; limestone. Weight: 359 grs. 13.00 x 8.80 x 4.00 cm. Used surface: 9.40 x 7.80 cm.

Primary form: cobble. Characteristics: slightly modified. Comments: dubious. The concavity is the most convincingly artificial feature. Degree of wear: 2-Medium. Wear marks: polishing. Surfaces: 1. Surface configuration: slightly concave. Surface texture: smoothed.

No. 16: sharpener (Fig. 31:2), Inv. No. F0540A (Drawing No. 0335). Complete; pumice. Weight: 12 grs. 4.50 x 3.90 x 2.70 cm. Shape by use. *Find No. 015.*

LEVEL V: Workshops in southern Area I

1.- Stratigraphy

When Building B was already ruined, an industrial hearth or oven (**L0067**) was built against the remains of its south wall (L0014) in Square BB/41. It was badly preserved, since a later feature filled by L0056 (a destruction layer covered by L0001) cut through it. Oven L0067 was drained by a channel (L0207) that ran to the W, then turned at right angle to the S and discharged out of the excavated area (**Plan IV**). Its dark fill (**L0206**) included flecks of whitish ash which were not randomly disposed, but oriented N-S, that is, parallel to the axis, an indication of the flow of some hot matter.

Eventually, oven L0067 fell into disuse and a mud brick platform was built, covering in part the remains of Building B and extending to the south and west in Squares BA/41, BA/42, BB/41 BB/42, AZ/41 and AZ/42 (in the last two squares it is still unexcavated). It was found in patches (**L0007**, L0065, L0201 and **L0202**), since several later pits and gullies had cut across it. This surface is associated with at least two complex fire features: oven **L0186** and drainage channel L0190.

Oven **L0186** (**Plan IV**) was built along with the platform or over it. It was indeed an oven, not a hearth, since the burned surface was found covered by mud bricks which would be the remains of the vault. Among them, a series of large sherds prove that, as in the case of L0013 and L0176, at least one big piece of pottery rested on the fire feature by the time of abandonment. At a certain moment of the use-life of L0186, a drain (L0184) about 25 cm wide was cut into the platform. The outflow was directed to a depressed area (L0183) to the north where the mud bricks had been removed. Some quantity of vitrified (faience?) slag was recovered from this shallow depression. In the fill of the drain (**L0185**), some copper/bronze slag was found. But oven L0186 had still another function: its fill was very rich in fish bones, a suggestion that it also served for cooking.³¹

Another drainage channel, L0190, coming from a still unexcavated fire feature, ran N-S directly W of oven L0186. Its fill, L0189, was carbonised and in part oxidized. Pottery was rather abundant, and some sherds in vertical position, well embedded in the fill, suggest that they formed a fringe for the runnel. Perhaps most of this feature remains in Baulk AZ/41-BA/41, which was not excavated until this level.

A later industrial oven (**L0274**, in NE corner of Square BA/41) had been built in pit

³¹For a comparable feature in Late Persian-Early Ptolemaic Tell Muqdam, see [Redmount and Friedman](#), *JARCE* 34, 59 and Fig. 2.

L0292 with silty clay mud bricks and *tina*. It was poorly preserved when found. A channel (L0315) drained fused matter from this oven towards WNW, across Baulk BA/41-BA/42, cutting through **L0244**, a laminated debris layer formed from washed out remains of Building B. Again, the outer end of the drain remains in unexcavated sediments. Inside its fill (**L0314**), a concentration of vitrified slag was found. Resting on the drain, a rather thick pottery plate (Inv. No. P0758A) was found, broken *in situ* (Plate V).

2.- Archaeological material

L0007 (Fig. 32)

I.- Pottery

a) Egyptian pottery

Nile silt clay

Fine ware

No. 1: jar (Fig. 32:1), Inv. No. P0618A (Drawing No. 0251)

RP	Nile B ₂	Ha ₁	---	ox.	2
----	---------------------	-----------------	-----	-----	---

Rim sherd; articulated exterior rim; compound lip. Rd: 14.00 cm 3/32; Wd: 0.50 cm; H₁: 2.70 + x cm. Surface colour: 10R 6/6 light red slip. Break: 10R 5/6 red core; 2.5 YR 6/6 light red oxidation zones. Surface treatment: polished. Eroded. *Find No. 008*. Another, Nile C₁, red slip smoothed surface, Rd: 16.00 cm 1/8.

Household ware

No. 2: bowl (Fig. 32:1), Inv. No. C-0322 [001]

Uncoated	Nile B ₂	W ₂
----------	---------------------	----------------

Rim sherd; inverted direct rim Rd: 28.00 cm 1/16; Wd: 0.73 cm; H₁: 3.73 + x cm; throwing lines outside; smoothed on the wheel.

No. 3: bowl (Fig. 32:1), Inv. No. C-0033 (2) [001]

Uncoated	Nile B ₂	W ₂
----------	---------------------	----------------

Rim sherd; everted direct rim. Rd: 22.00 cm 1/4; Wd: 0.70 cm; H₁: 3.00 + x cm; throwing lines outside; smoothed on the wheel; eroded inside and outside. Others, Rd: 24.00 cm 3/16. Nile C₁, Rd: 48.00 cm 1/32, Rd: 24.00 cm 1/16. Nile C₂, Rd: 26.00 cm 1/32.

No. 4: bowl (Fig. 32:1), Inv. No. C-0028 [003]

Uncoated	Nile C ₂	W ₂
----------	---------------------	----------------

Rim sherd; everted articulated interior rim, rounded lip. Rd: 42.00 cm 3/32; Wd: 0.80 cm; H₁: 4.40 + x cm; throwing lines outside; smoothed on the wheel.

No. 5: bowl (Fig. 32:1), Inv. No. C-0002 [002]

Uncoated	Nile B ₂	W ₂
----------	---------------------	----------------

Rim sherd; everted articulated exterior rim, rolled lip. Rd: 24.00 cm 1/16; Wd: 0.30 cm; H₁: 1.35 + x cm; throwing lines outside; smoothed on the wheel. Others, Rd: 24.00 cm 1/16, Rd: 24.00 cm 1/16.

No. 6: bowl (Fig. 32:1), Inv. No. C-0002 [003]

Uncoated	Nile C ₁	W ₂
----------	---------------------	----------------

Rim sherd; everted articulated interior and exterior rim, flattened lip. Rd: 22.00 cm 3/32; Wd: 0.68 cm; H₁: 4.20 + x cm; throwing lines outside; smoothed on the wheel; eroded inside.

No. 7: bowl (Fig. 32:1), Inv. No. C-0230 [006]

Uncoated	Nile B ₂	W ₂
----------	---------------------	----------------

Rim sherd; everted articulated interior and exterior rim. Rd: 31.00 cm 3/16; Wd: 0.75 cm; H₁: 2.69 + x cm; throwing lines outside; smoothed on the wheel. Another, Rd: 18.00 cm 1/16.

No. 8: bowl (Fig. 32:1), Inv. No. C-0028 [016]

Uncoated	Nile B ₂	W ₂
----------	---------------------	----------------

Rim sherd; everted articulated exterior rim. Rd: 30.00 cm 1/16; Wd: 0.60 cm; H₁: 2.50 + x cm; throwing lines outside; smoothed on the wheel. Another, Rd: 16.00 cm 1/16.

No. 9: bowl, Inv. No. C-0230 [007]

Uncoated	Nile B ₂	W ₂	W
----------	---------------------	----------------	---

Base fragment; rounded base; Wd: 0.49 cm; H₁: 2.20 + x cm; throwing lines outside; smoothed on the wheel.

No. 10: pilgrim flask (Fig. 32:1), Inv. No. P0004A (before Inv. No. P0061A. Drawing No. 0209)

Uncoated	Nile B ₂ s.	W ₂	W	ox.	2
----------	------------------------	----------------	---	-----	---

Base and body fragment; round base; lentil shape. Nd: 1.80 cm; Md: 11.20 cm; Wd: 0.04 cm; H₁: 12.70 + x cm; H₂: 6.20 cm. Surface colour: 5YR 6/4 light reddish brown. Break: 5YR 5/4 reddish brown. Decoration: incised concentric circles, three one side and two on the other, in the middle of the body. Surface treatment: smoothed.

No. 11: juglet, Inv. No. C-0002 [011]

Uncoated	Nile B ₂	Ha ₂
----------	---------------------	-----------------

Handle fragment; Hd: 1.30 x 0.90 cm, oval in section.

No. 12: jar (Fig. 32:1), Inv. No. C-0230 [005]

Uncoated	Nile B ₂	W ₂
----------	---------------------	----------------

Rim sherd; vertical direct rim. Rd: 14.00 cm 1/16; Wd: 0.66 cm; H₁: 3.00 + x cm; throwing lines inside; smoothed on the wheel. Others, Rd: 9.00 cm 7/32, Rd: 12.00 cm 1/16, Rd: 12.00 cm 3/32, Rd: 12.00 cm 1/16.

No. 13: jar (Fig. 32:1), Inv. No. C-0002 [005]

Uncoated	Nile B ₂	W ₂
----------	---------------------	----------------

Rim sherd; vertical articulated interior and exterior rim. Rd: 12.00 cm 3/32; Wd: 0.50 cm; H₁: 4.00 + x cm; throwing lines inside; smoothed on the wheel.

No. 14: jar (Fig. 32:2), Inv. No. C-0230 [004]

Uncoated	Nile E ₁	W ₂
----------	---------------------	----------------

Rim sherd; everted direct rim. Rd: 16.00 cm 1/32; Wd: 0.40 cm; H₁: 2.00 + x cm; throwing lines inside; smoothed on the wheel. Others, Nile B₂, Rd: 12.00 cm 1/32, Rd: 14.00 cm 1/16. Nile C₁, Rd: 18.00 cm 3/32.

No. 15: jar (Fig. 32:2), Inv. No. C-0028 (2) [023]

Uncoated	Nile B ₂	W ₂
----------	---------------------	----------------

Rim sherd; everted articulated exterior rim. Rd: 10.00 cm 1/16; Wd: 0.20 cm; H₁: 1.30 + x cm; throwing lines inside; smoothed on the wheel; eroded.

No. 16: jar, Inv. No. C-0002 [010]

Uncoated	Nile B ₂	W ₂	W
----------	---------------------	----------------	---

Base fragment; round base; Wd: 0.80 cm; H₁: 6.75 + x cm; throwing lines inside and outside; smoothed on the wheel. Others, 3 bases.

No. 17: jar, Inv. No. P0103A (Drawing No. 0158)

Uncoated	Nile B ₂	Ha ₁	Ha	med.	2
----------	---------------------	-----------------	----	------	---

Base and body fragment; raised base. Bd: 4.00 cm; Wd: 1.00 cm; H₁: 3.70 cm; H₂: 3.30 + x cm; H₄: 1.10 cm. Surface colour: 7.5YR 6/4 light brown. Break: 10R 5/8 red. Technical details: fingerprints inside. Surface treatment: smoothed by hand.

No. 18: storage jar (Fig. 32:2), Inv. No. C-0028 [002]

Uncoated	Nile C ₂	W ₂
----------	---------------------	----------------

Rim sherd; vertical exterior rim. Rd: 32.00 cm 1/8; Wd: 0.70 cm; H₁: 5.70 + x cm; throwing lines inside; smoothed on the wheel.

No. 19: storage jar (Fig. 32:2), Inv. No. P0102A (Drawing No. 0210)

Uncoated	Nile B ₂	W ₂	---	ox.	2
----------	---------------------	----------------	-----	-----	---

Rim sherd; wide mouthed; compound rim. Rd: 27.00 cm; Wd: 1.30 cm; H₁: 10.50 + x cm. Surface colour: 2.5YR 6/6 red. Break: thick core, 2.5YR 3/1 reddish brown; 2.5YR 6/8 red oxidation zones. Surface treatment: smoothed on the wheel.

No. 20: storage jar (Fig. 32:2), Inv. No. P0105A (Drawing No. 0257)

Uncoated	Nile C ₁	W ₁	---	med.	2
----------	---------------------	----------------	-----	------	---

Rim sherd; everted articulated exterior rim. Rd: 38.00 cm 1/16; Wd: 2.50 cm; H₁: 5.00 + x cm. Surface colour: 10R 5/6 red. Break: 10R 4/1 dark reddish grey core; 2.5YR 5/6 red oxidation zones. Surface treatment: smoothed on the wheel. Eroded; smoked.

No. 21: storage jar (Fig. 32:2), Inv. No. C-0028 [014]

Uncoated	Nile E ₁	W ₂
----------	---------------------	----------------

Rim sherd; everted articulated exterior rim. Rd: 22.00 cm 1/16; Wd: 0.60 cm; H₁: 3.10 + x cm; throwing lines inside; smoothed on the wheel.

No. 22: amphora, handle fragment, Nile E₂, Hd: 3.40 x 1.90 cm; smoothed.

Pottery with special functions

No. 23: tray (Fig. 32:2), Inv. No. C-0028 [015]

Uncoated	Nile E ₂	Ha ₁
----------	---------------------	-----------------

Fragment; D: 15.00 cm 5/32.

Body sherds, Nile B₂: 45.00 dm²; Nile C₁: 0.95 dm²; Nile C₂: 13.00 dm²; Nile E₁: 0.20 dm²; Nile E₂: 0.90 dm²; Marl A₄: 0.10 dm²; Marl F: 0.60 dm²; Marl F s.; Marl F v.s.

b) North Sinai/South Palestine pottery

Pottery with special functions

No. 24: "mortarium" (Fig. 32:2), Inv. No. P0380A (Drawing No. 0211)

Uncoated	II?.TG 47	W ₂	---	ox.	3
----------	-----------	----------------	-----	-----	---

Rim sherd; everted articulated symmetrical rim. Rd: 33.00 cm 7/64; Wd: 1.10 cm; H₁: 4.90 + x cm. Surface colour: 10YR 7/3 very pale brown. Break: 10YR 8/4 very pale brown. Surface treatment: smoothed on the wheel.

No. 25: amphora, Inv. No. C-0028, II.TG 08, body sherds: 0.35 dm².

c) Imported pottery***Levantine household ware***

No. 26: amphora, Inv. No. C-0028, IV.TG 01, body sherds: 1.00 dm².

No. 27: amphora, Inv. No. C-0028, IV.TG 03, body sherds: 1.00 dm².

No. 28: amphora, Inv. No. C-0028, IV.TG 06, body sherds: 0.20 dm².

No. 29: amphora, Inv. No. C-0028, IV.TG 07, body sherds: 0.20 dm².

No. 30: amphora, Inv. No. C-0028, IV.TG 11, body sherds: 0.60 dm².

No. 31: amphora (Fig. 32:2), Inv. No. C-0028 [004]

Uncoated	IV.TG 11	W ₂
----------	----------	----------------

Rim sherd; vertical articulated interior and exterior rim, trimmed lip. Rd: 10.00 cm 1/8; Wd: 0.50 cm; H₁: 3.00 + x cm; smoothed on the wheel.

No. 32: amphora, Inv. No. C-0028, IV.TG 18, body sherds: 0.30 dm².

No. 33: amphora, Inv. No. C-0028, IV.TG 23, body sherds: 0.20 dm².

No. 34: amphora, Inv. No. C-0028, IV.TG 24, body sherds: 0.10 dm².

No. 35: amphora, Inv. No. C-0028, IV.TG 29, body sherds: 0.20 dm².

No. 36: amphora, Inv. No. C-0028, IV.TG 32, body sherds: 0.10 dm².

No. 37: amphora, Inv. No. C-0028, IV.TG 51 (= TD IV.19), body sherds: 0.30 dm².

No. 38: amphora, Inv. No. C-0028, IV.TG 53 (= TD IV.09), body sherds: 0.40 dm².

No. 39: amphora, Inv. No. C-0028, IV.TG 54 (= TD IV.12), body sherds: 0.10 dm².

No. 40: amphora, Inv. No. C-0028, = TD IV.02, body sherds: 0.20 dm².

No. 41: amphora, Inv. No. C-0028 [022]

Uncoated	= TD IV.02	Ha ₂
----------	------------	-----------------

Handle fragment; Hd: 2.80 x 1.50 cm; smoothed.

No. 42: amphora, Inv. No. C-0028, = TD IV.08, body sherds: 0.70 dm².

Phoenician household ware

No. 43: amphora, Inv. No. C-0028, IV.TG 22 = IV.Phoen?04, body sherds: 0.20dm².

Cypriote household ware

No. 44: amphora, Inv. No. C-0028, VI.TG 04, body sherds: 0.10 dm².

No. 45: amphora, Inv. No. C-0028, VI.TG 44, body sherds: 0.10 dm².

Aegean household ware

No. 46: amphora, Inv. No. C-0028, VII.TG 13 (Samian), body sherds: 0.10 dm².

No. 47: amphora (Fig. 32:2), Inv. No. P0104B (Drawing No. 0083. F17)

Uncoated	VII.TG 35 (Chian)	W ₂	---	re.	2
----------	-------------------	----------------	-----	-----	---

Rim sherd; inverted modelled rim. Rd: 10.00 cm 11/32; Nd: 11.50 cm; Wd: 0.50 cm; H₁: 4.00 + x cm; H₃: 3.00 cm. Surface colour: 5YR 5/6 yellowish red. Break: 5YR 5/4 reddish brown core; 5YR 5/6 yellowish red oxidation zones. Technical details: modelled rim forming an interior lip. Surface treatment: smoothed on the wheel. Observations: in the Abu Seifa exhibition room. *Find No. 017*.

No. 48: amphora, Inv. No. C-0028, VII.TG 39, body sherds: 0.10 dm².

II.- Finds***Religion***

Amulet

No. 49: wdjat (Plate 12), Inv. No. F0014A (Drawing No. 0180-0181). Fragmentary; faience; moulded. 1.60 x 1.10 x 0.30 cm; colour: 2.5YR 8/1 white. Description: barrel-shaped *wdjat* with the characteristic curving shape, incised lines. Observations: coarse surface. *Find No. 020*.

Personal object

No. 50: bead (Fig. 32:3), Inv. No. F1003A (Drawing No. 0946). Complete; mended; faience; moulded. 1.90 x 2.00-6.00 x 0.50 cm; colour: light blue. Barrel shape; perforation: 1 mm wide.

Tool

No. 51: grinding stone (Fig. 32:3), Inv. No. F0426A (Drawing No. 0336). Fragmentary; red quartzite? 6.40 x 8.20-7.30 x 2.60 cm; colour: 2YR 6/2 (pale red). Degree of ware: 3-Hard. Wear type: abrasion. Wear marks: fine striations. Surfaces: 1. Surface configuration: flat. Surface texture: smoothed. Residues: salt. Stroke: perpendicular.

Object of unknown use

No. 52: fragment of an object, Inv. No. F0354A. Faience; moulded. 3.30 x 2.00 x 1.40 cm; colour: Chart 1 for gley 10Y 6/1 greenish grey. Frontal view shape: complex; side view shape: flat-convex (part of a *wdajt*?).

L0013**Pottery****a) Egyptian pottery****Nile silt clay****Household ware**

No. 1: jar, Inv. No. C-0043 [001]

Uncoated	Nile B ₂	W ₂
----------	---------------------	----------------

Rim sherd. Rd: 10.00 cm 3/16; smoothed on the wheel; eroded.

Body sherds, Nile B₂ and Nile E₁.

b) Imported pottery**Cypriote household ware**

No. 2: amphora, Inv. No. C-0043, VI.TG 04, body sherd.

No. 3: amphora, Inv. No. C-0043, VI.TG 49, body sherd.

L0067 (Fig. 33)**I.- Pottery****a) Egyptian pottery****Nile silt clay****Household ware**

No. 1: bowl (Fig. 33), Inv. No. C-0637 [014]

Uncoated	Nile C ₁	W ₂
----------	---------------------	----------------

Rim sherd; everted direct rim. Rd: 20.00 cm 1/8; Wd: 0.50 cm; H₁: 2.10 + x cm. Throwing lines outside; eroded.

No. 2: bowl (Fig. 33), Inv. No. C-0637 [012]

Uncoated	Nile B ₂	W ₂
----------	---------------------	----------------

Rim sherd; everted direct rim. Rd: 30.00 cm 1/8; Wd: 1.00 cm; H₁: 3.50 + x cm. Throwing lines outside; smoothed on the wheel; eroded inside.

No. 3: carinated bowl (Fig. 33), Inv. No. C-0637 [011]

Uncoated	Nile B ₂	W ₂
----------	---------------------	----------------

Rim sherd; carinated walls; everted direct rim. Rd: 16.00 cm 1/8; Wd: 0.50 cm; H₁: 2.50 + x cm. Throwing lines outside; eroded.

No. 4: jar (Fig. 33), Inv. No. C-0637 [013]

Uncoated	Nile B ₂	W ₂
----------	---------------------	----------------

Rim sherd; inverted direct rim. Rd: 12.00 cm 1/8; Wd: 0.55 cm; H₁: 2.70 + x cm. Throwing lines inside; smoothed on the wheel; eroded. Others, Rd: 12.00 cm 5/32, Rd: 12.00 cm 1/8.

No. 5: jar (Fig. 33), Inv. No. C-0637 [004]

Uncoated	Nile C ₁	W ₂
----------	---------------------	----------------

Rim sherd; inverted articulated exterior rim, modelled lip. Rd: 16.00 cm 3/32; Wd: 0.65 cm; H₁: 4.00 + x cm. Throwing lines inside; smoothed on the wheel; eroded.

No. 6: jar (Fig. 33), Inv. No. C-0637 [002]

Uncoated	Nile B ₂	W ₂
----------	---------------------	----------------

Rim fragment; slightly inverted articulated exterior rim, modelled lip. Rd: 16.00 cm 3/32; Wd: 0.60 cm; H₁: 3.40 + x cm. Throwing lines inside; eroded and salt incrustated outside.

No. 7: jar (Fig. 33), Inv. No. C-0637 [007]

Uncoated	Nile B ₂	W ₂
----------	---------------------	----------------

Rim sherd; vertical direct rim. Rd: 14.00 cm 3/32; Wd: 0.60 cm; H₁: 4.30 + x cm. Throwing lines inside; eroded. Others, Rd: 10.00 cm 3/32, Rd: 19.00 cm 3/32.

No. 8: globular jar (Fig. 33), Inv. No. C-0637 [010]

Uncoated	Nile C ₁	W ₂
----------	---------------------	----------------

Rim fragment; vertical direct rim. Rd: 12.00 cm 3/32; Wd: 0.65 cm; H₁: 3.20 + x cm. Throwing lines inside; smoothed on the wheel.

No. 9: globular? jar (Fig. 33), Inv. No. C-0637 [001]

Uncoated	Nile B ₂	W ₂
----------	---------------------	----------------

Rim and shoulder fragment; globular shape?; vertical articulated interior rim, modelled lip. Rd: 10.00 cm 1/4; Wd: 0.60 cm; H₁: 4.30 + x cm. Throwing lines inside; eroded and smoked.

No. 10: jar, Inv. No. C-0637 [020]

Uncoated	Nile B ₂	Ha ₂
----------	---------------------	-----------------

Handle fragment; Hd: 1.70 x 1.20 cm, oval in section; 1; single strap; eroded.

No. 11: storage jar (Fig. 33), Inv. No. C-0637 [016]

Uncoated	Nile B ₂	W ₂
----------	---------------------	----------------

Rim sherd; inverted articulated interior and exterior rim, flattened lip. Rd: 30.00 cm 1/8; Wd: 1.00 cm; H₁: 7.60 + x cm. Throwing lines inside; eroded.

No. 12: storage jar (Fig. 33), Inv. No. C-0637 [015]

Uncoated	Nile B ₂	W ₂
----------	---------------------	----------------

Rim sherd; vertical articulated interior and exterior rim, flat lip. Rd: 20.00 cm 1/8; Wd: 1.00 cm; H₁: 6.40 + x cm. Throwing lines inside; eroded.

Pottery with special functions

No. 13: bakery tray (Fig. 33), Inv. No. C-0637 [017]

Uncoated	Nile C ₂	W ₁
----------	---------------------	----------------

Rim fragment; everted direct rim. Rd: 22.00 cm 1/4; Wd: 0.65 cm; H₁: 4.70 + x cm. Eroded and smoked.

Body sherds, Nile B₂: 32.00 dm²; Nile C₂: 4.00 dm².

b) North Sinai/South Palestine pottery

Household ware

No. 14: amphora, II.TG 08, body sherds: 0.10 dm².

c) Imported pottery

Levantine fine ware

No. 15: jar (Fig. 33), Inv. No. P2031A (Drawing No. 0458)

RP	IV.TG 51 (= TD IV.19)	Ha ₂	---	me.	3
----	-----------------------	-----------------	-----	-----	---

Handle fragment. Hd: 1.30 x 1.70 cm. Surface colour: 10R 4/8 red slip. Break: 7.5R 6/6 reddish yellow. Surface treatment: polished, high lustre. Partially eroded.

Levantine household ware

No. 16: amphora, IV.TG 18, body sherds: 0.10 dm².

No. 17: amphora, IV.TG 23, body sherds: 0.10 dm².

No. 18: amphora, IV.TG 24, body sherds: 0.10 dm².

No. 19: amphora, IV.TG 51 (=TD IV.19) , body sherds: 0.10 dm².

No. 20: bowl (Fig. 33), Inv. No. C-0637 [0003]

Uncoated	IV.TG 53	W ₂
----------	----------	----------------

Rim sherd; incurved walls, inverted direct rim. Rd: 20.00 cm 1/16; Wd: 0.45 cm; H₁: 3.90 + x cm. Throwing lines inside; smoothed on the wheel.

Aegean household ware

No. 21: amphora, VII.TG 48 (Samian), body sherds: 0.10 dm².

II.- Finds

Personal object

No. 22: shell used as a bead (Fig. 33), Inv. No. F0874A (Drawing No. 0931). 1.50 x 0.70 cm.

L0185 (Fig. 34)

I.- Pottery

a) Egyptian pottery

Nile silt clay

Household ware

No. 1: jar (Fig. 34), Inv. No. C-0392 [001]

Uncoated	Nile B ₂	W ₂
----------	---------------------	----------------

Rim sherd; vertical direct rim. Rd: 10.00 cm 1/4; Wd: 0.55 cm; H₁: 3.15 + x cm; throwing lines inside; smoothed on the wheel.

No. 2: amphora (Fig. 34), Inv. No. C-0392 [002]

Uncoated	Nile B ₂	W ₂
----------	---------------------	----------------

Rim sherd; vertical articulated exterior and interior rim. Rd: 12.00 cm 1/8; Wd: 0.70 cm; H₁: 2.58 + x cm. Throwing lines inside; whitish self slip for overfired; smoothed on the wheel.

Egyptian marls**Household ware****No. 3: jar**, Inv. No. P0802A

P	Marl F s.	W ₂	---	ox.	3
---	-----------	----------------	-----	-----	---

Body sherd. Wd: 0.55 cm; H₁: 1.90 + x cm. Surface colour: 2.5YR 4/4 reddish brown self slip. Break: 5YR 5/6 yellowish red. Surface treatment: polished, low lustre.

Body sherds, Nile B₂: 12.25 dm²; Nile C₁: 1.50 dm²; Nile C₂: 0.50 dm².

b) Imported pottery**Aegean fine ware****Black-on-Red II (IV) ware****No. 4: juglet**, Inv. No. P0784A

RPMO	VII.TG 39	W ₂	---	ox.	3
------	-----------	----------------	-----	-----	---

Rim sherd; everted pinched rim. Rd: 4.00-4.50 cm; Wd: 0.35 cm; H₁: 1.20 + x cm. Surface colour: 10R 4/6 red slip. Break: 2.5 YR 5/6 red. Technical details: throwing lines inside. Decoration: a painted line on the rim, inside and outside, 2.5YR 2.5/1 black. Surface treatment: polished, low lustre.

II.- Finds**Product**

No. 5: faience slag, Inv. No. F1060A.

L0186

Pottery, Nile B₂, Inv. No. C-9008, **body sherds**.

Find, a **net weight** for fishing, lead, fragmentary.

L0202 (Fig. 35)**I.- Pottery****a) Egyptian pottery****Nile silt clay****Household ware****No. 1: cooking pot?** (Fig. 35), Inv. No C-0612 [002]

Uncoated	Nile B ₂	W ₂
----------	---------------------	----------------

Rim sherd; inverted articulated exterior rim, modelled lip. Rd: 14.00 cm 3/32; Wd: 0.80 cm; H₁: 2.36 + x cm. Throwing lines inside; eroded outside.

No. 2: jar, Inv. No C-0612 [001]

Uncoated	Nile B ₂	Ha ₂
----------	---------------------	-----------------

Handle fragment. Hd: 2.87 x 1.40 cm. Others, Hd: 2.50 x 1.70 cm; Nile C₂, eroded.

Pottery with special functions

No. 3: bakery tray, Inv. No. P1187A (Drawing No. 0500)

Uncoated	Nile C ₂	W ₁	Ha	ox.	2
----------	---------------------	----------------	----	-----	---

Complete, fragmentary; everted direct rim. Rd: 22.00 cm 1/8; Bd: 18.00 cm 1/8; Wd: 2.20 cm; H₁: 5.30 cm. VI: 415. Surface colour: 2.5YR 5/6 red. Break: 2.5YR 5/4 reddish brown. Surface treatment: uneven.

Body sherds, Nile B₂: 22.25 dm²; Nile C₁: 0.60 dm²; Nile C₂: 2.60 dm²; Marl F.

b) Imported pottery

Levantine household ware

No. 4: amphora, IV.TG 18, body sherd: 0.10 dm².

No. 5: amphora, IV.TG 23, burnt, body sherd: 0.10 dm²; handle fragment, eroded.

L0206 (Fig. 36)

I.- Pottery

a) Egyptian pottery

Nile silt clay

Household ware

No. 1: bowl (Fig. 36), Inv. No C-0514 [009]

Uncoated	Nile E ₁	W ₂
----------	---------------------	----------------

Rim sherd; everted direct rim. Rd: 24.00 cm 1/16; Wd: 0.90 cm; H₁: 4.43 + x cm. Throwing lines outside; smoothed on the wheel; smoked inside (used as a lid). Another, Nile B₂, Rd: 26.00 cm 1/32.

No. 2: jar (Fig. 36), Inv. No C-0514 [007]

Uncoated	Nile B ₂	W ₂
----------	---------------------	----------------

Rim sherd; everted direct rim. Rd: 19.00 cm 1/16; Wd: 0.70 cm; H₁: 2.70 + x cm Surface treatment: wheel smoothed inside and outside. Technical details: Throwing lines inside; smoothed on the wheel. Another, Rd: 10.00 cm 5/32.

No. 3: storage jar (Fig. 36), Inv. No C-0514 [005]

Uncoated	Nile C ₁	W ₂
----------	---------------------	----------------

Rim sherd; everted articulated exterior rim, modelled lip. Rd: 20.00 cm 1/8; Wd: 0.90 cm; H₁: 4.76 + x cm. Throwing lines inside; eroded.

No. 4: amphora, Inv. No C-0514 [013]

Uncoated	Nile B ₂	W ₂
----------	---------------------	----------------

Handle fragme Nile B₂t; Hd: 3.50 x 1.90 cm; eroded.

Body sherds, Nile B₂: 16.80 dm²; Nile C₁: 0.60 dm²; Nile C₂: 0.60 dm²; Nile E₂: 0.50 dm²; Marl A₄: 0.10 dm²; Marl F: 0.10 dm².

b) Imported pottery

Levantine household ware

No. 5: pilgrim flask (Fig. 36), Inv. No. P1178A (Drawing No. 0711)

Uncoated	IV.TG 07	W ₂ + Ha ₂	---	re.	3
----------	----------	----------------------------------	-----	-----	---

Handle, neck and body fragment; barrel shape. Md: 9.20 + x cm; Wd: 0.50 cm; H₁: 4.50 + x cm; Hd: 1.00 x 1.20 cm. Surface colour: 7.5YR 6/4 light brown. Break: 7.5YR 4/1 dark grey. Surface treatment: smoothed.

No. 6: amphora, IV.TG 11, body sherds: 0.10 dm².

No. 7: amphora, IV.TG 51 (= TD IV.19), body sherds: 0.10 dm².

Aegean household ware

No. 8: amphora, VII.TG 46 (Chian), body sherds: 0.10 dm².

II.- Finds

Religion

No. 9: Horus head?, Inv. No. F0319A. Fragmentary; steatite? 1.20 x 1.40 x 1.10 cm; colour: 10Y 6/1 (greenish grey). Function: amulet. *Find No. 024.*

Personal objects

No. 10: bead (fragment), Inv. No. F0316A. Faience; destroyed. *Find No. 022.*

No. 11: bead, Inv. No. F0320A. Complete; faience; moulded. 0.20 x 0.30 cm; cylindrical shape. *Find No. 025.*

No. 12: bead, Inv. No. F0402A (Drawing No. 0274). Complete; faience; moulded. 0.50 x 0.15 cm; colour: 10Y 7/1 (light greenish grey); cylindrical shape; perforation: 1 mm. *Find No. 022.*

Object of unknown use

No. 13: fragment of an object, Inv. No. F0382A + F0383A. Marble? 1.50 x 0.90 x 0.60 cm. *Find No. 040.*

Product

No. 14: pottery slag, Inv. No. F0562A.

L0244 (Fig. 37)

I.- Pottery

a) Egyptian pottery

Nile silt clay

Household ware

No. 1: bowl (Fig. 37:1), Inv. No. C-0430 [012]

Uncoated	Nile C ₁	W ₁
----------	---------------------	----------------

Rim sherd, everted direct rim. Rd: 30.00 cm 1/16; Wd: 0.90 cm; H₁: 3.20 + x cm. Throwing lines outside and inside; smoothed on the wheel. Others, Nile C₂, Rd: 26.00 cm 1/8, Rd: 34.00 cm 1/16, Rd: 36.00 cm 1/16.

No. 2: bowl (Fig. 37:1), Inv. No. C-0430 [010]

RS	Nile B ₂	W ₂
----	---------------------	----------------

Rim sherd, everted articulated exterior rim, trimmed lip. Rd: 28.00 cm 1/16; Wd: 0.85 cm; H₁: 2.90 + x cm; throwing lines outside and inside; smoothed on the wheel. Another, Rd: 28.9 cm 1/16.

No. 3: bowl (Fig. 37:1), Inv. No. C-0430 [009]

RS	Nile B ₂	W ₂
----	---------------------	----------------

Rim sherd; slightly everted articulated symmetrical rim. Rd: 24.00 cm 1/16; Wd: 0.700cm; H₁: 2.00 + x cm; throwing lines outside and inside; smoothed on the wheel.

No. 4: jug, Inv. No. C-0430 [026]

Uncoated	Nile B ₂	W ₂
----------	---------------------	----------------

Handle fragment; oval section, 1; 1 strap. Md: 20.00 cm 1/8; Wd: 0.80 cm; H₁: 8.27 + x

cm; Hd: 2.02 x 1.90 cm. Throwing lines inside; handle attached to body; smoothed on the wheel. Another, Hd: 4.30 x 3.10 cm.

No. 5: jug, Inv. No. C-0430 [025]

Uncoated Nile C₂ Ha₂ + W₂

Handle and body fragment. Md: 22.0 cm 1/8; Wd: 0.47 cm; H₁: 6.30 + x cm; 1 strap; Hd: 2.40 x 1.90 cm. Throwing lines inside; handle attached to body; smoothed.

No. 6: jar (Fig. 37:1), Inv. No. C-0430 [003]

Uncoated Nile B₂ W₂

Rim sherd, inverted direct rim. Rd: 12.00 cm 3/32; Wd: 0.60 cm; H₁: 3.00 + x cm. Throwing lines inside; smoothed on the wheel. Others, Rd: 10.00 cm 1/16, Rd: 12.00 cm 3/32. Nile B₂/C₁, Rd: 10.00 cm 3/32.

No. 7: jar (Fig. 37:1), Inv. No. C-0430 [001]

Uncoated Nile E₂ W₂

Rim sherd, vertical direct rim. Rd: 12.00 cm 1/8; Wd: 0.70 cm; H₁: 3.10 + x cm. Throwing lines inside; smoothed on the wheel.

No. 8: jar (Fig. 37:1), Inv. No. C-0516 [002]

Uncoated Nile B₂ W₂

Rim, neck and shoulder fragment; vertical direct rim. Rd: 6.00 cm 7/32; Wd: 0.40-0.45 cm; H₁: 3.30 + x cm; H₂: 1.50 cm. Throwing lines inside; smoothed on the wheel.

No. 9: jar (Fig. 37:1), Inv. No. C-0430 [032]

Uncoated Nile B₂ W₂

Rim and neck fragment; slightly everted direct rim. Rd: 10.40 cm 1/1; Nd: 8.30 cm; Wd: 0.50-0.70 cm; H₁: 5.35 + x cm. Throwing lines inside; smoothed on the wheel. Others, Rd: 12.00 cm 1/8. Rd: 10.00 cm 7/32.

No. 10: jar, Inv. No. C-0516 [003]

Uncoated Nile B₂ W₂ W

Base fragment; round base. Md: 8.80 cm; Wd: 0.70-0.80 cm; H₁: 3.50 + x cm. Throwing lines inside and outside; smoothed on the wheel. Others, 2 bases.

No. 11: storage jar (Fig. 37:1), Inv. No. C-0430 [019]

Uncoated Nile B₂ W₂

Rim sherd, inverted direct rim. Rd: 24.00 cm 3/32; Wd: 1.10 cm; H₁: 5.00 + x cm. Throwing lines inside; smoothed on the wheel.

No. 12: storage jar (Fig. 37:1), Inv. No. C-0430 [021]

Uncoated Nile C₂ W₂

Rim sherd, inverted articulated interior rim. Rd: 34.00 cm 3/32; Wd: 1.00 cm; H₁: 4.10 + x cm. Throwing lines inside; smoothed on the wheel.

No. 13: storage jar (Fig. 37:1), Inv. No. C-0430 [020]

Uncoated Nile C₂ W₂

Rim sherd, inverted articulated exterior rim. Rd: 22.00 cm 1/8; Wd: 1.10 cm; H₁: 4.30 + x cm. Throwing lines inside; smoothed on the wheel. Another, Rd: 26.00 cm 1/16.

Body sherds, Nile B₂: 67.60 dm²; Nile E₂: 0.10 dm²; Marl A₄ coarse: 0.10 dm²; Marl F:

0.30 dm².

Egyptian marls

Household ware

No. 14: bowl (Fig. 37:1), Inv. No. C-0430 [013]

Uncoated	Marl F v.s.	W ₂
----------	-------------	----------------

Rim sherd, everted direct rim. Rd: 16.00 cm 3/32; Wd: 0.80 cm; H₁: 1.60 + x cm. Throwing lines outside; smoothed on the wheel.

No. 15: amphora (Fig. 37:1), Inv. No. C-0516 [004]

Uncoated	Marl F	W ₂
----------	--------	----------------

Rim sherd, inverted direct rim. Rd: 10.0 cm 1/8; Wd: 1.00 cm; H₁: 2.60 cm. Throwing lines inside; smoothed on the wheel.

No. 16: amphora, Inv. No. C-0516

Uncoated	Marl F	Ha ₂
----------	--------	-----------------

Handle fragment; 1 strap; Hd: 3.50 x 1.70 cm; smoothed.

b) North Sinai/South Palestine pottery

Household ware

No. 17: amphora (Fig. 37:1), Inv. No. P1287A (Drawing No. 0706)

Coated	II.TG 10	W ₂	---	ox.	3
--------	----------	----------------	-----	-----	---

Rim and body sherd; vertical articulated interior rim. Rd: 8.00 cm 3/16; Wd: 0.60 cm; H₁: 3.52 + x cm. Surface colour: 10YR 7/3 very pale brown slip. Break: 10YR 6/6 brownish yellow. Throwing lines inside. Surface treatment: smoothed on the wheel.

c) Imported pottery

Levantine household ware

No. 18: amphora (Fig. 37:2), Inv. No. P1286A (Drawing No. 0706)

Uncoated	= TD IV.08	Ha ₂	---	med.	3
----------	------------	-----------------	-----	------	---

Handle fragment. Wd: 1.00 cm; Hd: 2.30 x 3.50 cm. Surface colour: 10YR 8/4 very pale brown. Break: 2.5YR 7/1 light reddish brown core; 2.5YR 6/6 light red oxidation zones. Throwing lines inside. Surface treatment: smoothed on the wheel.

No. 19: amphora, Inv. No. C-0430, IV.?.; body sherd.

Cypriote fine ware

No. 20: juglet (Fig. 37:2), Inv. No. P0870A (Drawing No. 0400)

Uncoated	VI.TG 04	Ha ₂	---	ox.	3
----------	----------	-----------------	-----	-----	---

Handle fragment; round section; single strap. Hd: 0.60 x 0.60 cm. Surface colour: 2.5YR 7/6 light red. Break: 2.5YR 7/6 light red. Surface treatment: smoothed by hand.

II.- Finds

Suspended weight

No. 21: spindle whorl (Fig. 37:2), Inv. No. F0498 (Drawing No. 0275). Complete, clay; 2.80 x 2.20 cm; colour: 5YR 2.5/2 dark reddish brown and 7.5 YR 5/3 brown; oval shape; perforation: 4.5 mm. SCA No. 2028. Find No. 006.

L0274 (Fig. 38)

a) Egyptian pottery

Nile silt clay**Household ware****No. 1: jar (Fig. 38), Inv. No C-0450 [001]**Uncoated | Nile B₂ | W₂Rim sherd; everted direct rim, round lip. Rd: 8.00 cm 3/16; Wd: 0.70 cm; H₁: 4.53 + x cm; throwing lines inside; smoothed on the wheel.**No. 2: vessel, Nile B₂, ring base, very small fragment.****Egyptian marls****Fine ware****No. 3: juglet (Fig. 38), Inv. No C-0450 (2) [001]**RS | Marl F | Ha₂ + W₂

Handle and wall fragment; attached vertical loop handle. Wd: 0.40 cm; Hd: 1.50 x 1.12 cm; single strap. Surface colour: 10R 4/8 red slip. Throwing lines inside. Decoration: a black painted band, 8 mm wide, along the handle; smoothed.

Body sherds, Nile B₂: 0.20 dm²; Nile C₂ c.: 0.60 dm²; Marl F.**b) Imported pottery****Levantine household ware****No. 4: amphora, IV.TG 07, body sherd.****No. 5: amphora, IV.TG 09, body sherd.****No. 6: amphora, IV.TG 29, body sherd.****No. 7: amphora, VI.TG 44, body sherd.****No. 8: amphora, IV.TG 51 (= TD IV.19), body sherd.****L0314 (Fig. 39)****Pottery****a) Egyptian pottery****Nile silt clay****Household ware****No. 1: bowl (Fig. 39), Inv. No. P0758A (Drawing No. 0302)**RS | Nile B₂ | W₂ | base finished on the wheel | ox. | 2Nearly complete; mended; articulated exterior lip; pointed base. Rd: 22.50 cm; Md: 5.80 cm; Wd: 0.60 cm; H₁: 7.00 cm. VI: 321. Surface colour: 10R 5/3 weak red slip. Throwing lines outside. Break: ---. Surface treatment: smoothed on the wheel. Slip preserved inside and on some parts of the exterior surface.**No. 2: jar (Fig. 39), Inv. No. C-0432 [001]**Uncoated | Nile B₂ | W₂Rim sherd; everted direct rim, round lip. Rd: 12.00 cm 5/32; Wd: 0.40 cm; H₁: 3.90 + x cm; throwing lines inside; smoothed on the wheel; eroded.**No. 3: jar, Inv. No. C-0432**Uncoated | Nile B₂ | ---

Handle and wall fragment; attached vertical loop handle; Wd: 1.00 cm; eroded.

No. 4: bakery tray, Inv. No. C-0432Uncoated | Nile C₁ | --

Rim sherds; very eroded.

Body sherds, Nile B₂, Nile C₂, Marl A₄, Marl F.

b) Imported pottery

Levantine household ware

No. 5: amphora, IV.TG 07, body sherds.

No. 6: amphora, IV.TG 18, body sherds.

No. 7: amphora, IV.TG 51 (=TD IV.19), body sherds.

LEVEL VI

Conflagration and abandonment (L0001)

1.- Description

After the multiplication of workshop installations, an important functional transformation took place in Area I. Deep trenches or ditches were dug, cutting across walls, features and undifferentiated fill (*ridim*). Since many of them crisscross at right angles, it is possible that they were part of constructions, and of an insubstantial kind, as no bricks were found in association. They were found filled by L0001, a dark, charcoal-rich sediment, which forms a thick cover for the whole area. This is a conflagration layer, as indicated by lenses of oxidation both in its interior and in the unconformable contacts with the underlying strata. Sherds are very abundant in **L0001**, and sometimes quite large. This last observation means that neither treading nor cleaning of the surfaces were significant. In fact, no solid structure was built in Area I after L0001 was deposited. But the area was not altogether deserted: some small pits were dug in antiquity for unknown reasons, fish bones are very abundant, sometimes forming lenses or associate to a small hearth; material culture is varied.

The modern topsoil covers **L0001** in unconformity (Plate VIII).

2.-Archaeological material (Fig. 40)

I.- Pottery

a) Egyptian pottery

Nile silt clay

Egyptian fine ware

No. 1: carinated pot (Fig. 40:1), Inv. No. P1062A (Drawing No. 0544)

RP	Nile B ₂	W ₂	---	ox.	2
----	---------------------	----------------	-----	-----	---

Rim and body sherd; carinated sided walls. Rd: 13.60 cm ¹/₄; Nd: 13.00 cm; Md: 14.00 cm; Wd: 0.45-0.50 cm; H₁: 3.20 + x cm. Surface colour: 10R 5/6 red slip. Break: 10R 5/1 reddish grey core; 10R 5/8 red oxidation zones. Surface treatment: polished.

No. 2: juglet (Fig. 40:1), Inv. No. P0624 (Drawing No. 0255)

WP	Nile clay	W ₂	---	ox.	2-3
----	-----------	----------------	-----	-----	-----

Nearly complete; flat base 1/1, globular shape, rim broken; attached vertical loop handle from neck to body. Rd: 1.60 cm; Nd: 1.65 cm; Bd: 2.50 cm; Md: 6.00 cm; Wd: 0.50 cm; H₁: 7.80 cm; H₂: 3.00 cm; H₃: 2.85 cm; Hd: 0.85 x 0.65 cm; single strap. Surface colour: 5YR 7/4 pink slip. Break: 5YR 6/6 reddish yellow. Surface treatment: polished, low lustre. SCA No. 2018. *Find No. 011.*

No. 3: juglet (Fig. 40:1), Inv. No. P1237A (Drawing No. 0518)

RP	Nile E ₂	W ₂ + Ha ₂	---	ox.	2-3
----	---------------------	----------------------------------	-----	-----	-----

Body and handle fragment; globular shape. Md: 8.00 cm; Wd: 1.30 cm; H₁: 7.00 + x cm; Hd: 1.20 x 1.00 cm; round in section; 1; single strap. Surface colour: 10R 4/6 red slip. Break: 7.5YR 6/3 light brown interior; 5YR 5/4 reddish brown exterior. Technical details: throwing lines outside; very heavy vessel. Surface treatment: polished. *Find No. 012.*

No. 4: juglet (Fig. 40:2), Inv. No. P1155A (Drawing No. 0519)

P	Nile E ₂ f.	W ₂ + Ha ₂	---	ox.	2-3
---	------------------------	----------------------------------	-----	-----	-----

Neck, body and handle fragment. Nd: 2.00 cm 1/4; Md: 10.00 cm; Wd: 0.50 cm; H₁: 7.50 + x cm; H₄: 0.50 cm; Hd: 1.10 x 1.50 cm; oval in section; 1; single strap. Surface colour: 5YR 6/6 reddish yellow. Break: 5YR 5/6 yellowish red. Technical details: throwing lines inside and outside. Surface treatment: polished, medium lustre.

No. 5: juglet (Fig. 40:2), Inv. No. P1111A (Drawing No. 0520)

P?	Nile E ₂ f.	W ₂	W	ox.	2-3
----	------------------------	----------------	---	-----	-----

Base, body and shoulder fragment; round base. Nd: 3.50 cm; Md: 6.10 cm; Wd: H₁: 7.00 + x cm; H₂: 3.00 cm; H₃: 0.20 cm; Hd: 1.10 x 0.90 cm; 1; single strap. Surface colour: ---. Break: ---. Technical details: throwing lines inside; base slightly twisted by hand, then smoothed and flattened with the finger. Surface treatment: polished. Completely smoked. *Find No. 010.*

No. 6: juglet (Fig. 40:2), Inv. No. P0077A (Drawing No. 0001)

RP	Nile E ₂	Ha ₁	Ha	med.	2
----	---------------------	-----------------	----	------	---

Base 1/1 and wall fragment; bag shape; ring base (R₁); convex side wall. Bd: 3.00 cm; Md: 6.60 cm; Wd: 1.00 cm; H₁: 6.30 + x cm; H₂: 2.50 cm. Surface colour: 7.5YR 6/8 reddish yellow; 2.5YR 4/4 dusky red slip. Break: 7.5YR 7/8 reddish yellow. Surface treatment: burnished by hand. Observations: sediments inside.

No. 7: juglet (Fig. 40:3), Inv. No. P1057A (Drawing No. 0436)

RP	Nile E ₂	Ha ₁	Ha	ox.	2
----	---------------------	-----------------	----	-----	---

Base and body fragment; bag shape; ring base (R₁). Bd: 3.00 cm 1/4; Md: 9.00 cm; Wd: 0.95-1.45 cm; H₁: 8.00 + x cm; H₂: 3.00 cm. Surface colour: 10R 4/6 red slip. Break: 2.5YR 6/6 light red. Surface treatment: polished, low lustre. Observations: sediments inside.

No. 8: juglet, Inv. No. P0391A (Drawing No. 0227)

RP	Nile clay	Ha ₂	---	ox.	2-3
----	-----------	-----------------	-----	-----	-----

Handle fragment. Hd: 1.00 x 0.80 cm. Surface colour: 10R 4/6 red slip. Break: 5YR 5/6 yellowish red. Surface treatment: polished.

No. 9: jar (Fig. 40:3), Inv. No. C-0014 (2) [001]

RP	Nile B ₂	W ₂
----	---------------------	----------------

Rim and neck sherd; flaring neck, everted articulated exterior rim, round lip. Rd: 12.00 cm 3/32; Wd: 0.90 cm; H₁: 4.50 + x cm. Throwing lines inside; polished.

Egyptian painted ware***Black-on Red slip ware*****No. 10: juglet (Fig. 40:3), Inv. No. P0876A (Drawing No. 0951)**

RP[MO]	Nile B ₂	W ₂	---	re.	2-3
--------	---------------------	----------------	-----	-----	-----

Body sherd. Md: ca. 10.00 + x cm; Wd: 0.35 cm; H₁: 1.50 + x cm. Surface colour: 10R 5/6

red slip. Break: 10R 4/1 dark reddish grey. Decoration: ---. Surface treatment: polished, medium lustre.

Household ware

No. 11: bowl (Fig. 40:3), Inv. No. C-0380 [027]

Uncoated	Nile B ₂	W ₂
----------	---------------------	----------------

Rim sherd; incurved walls, inverted direct rim. Rd: 24.00 cm 1/16; Wd: 0.75 cm; H₁: 5.80 + x cm. Throwing lines outside and inside; smoothed on the wheel. Another, Rd: 10.00 cm 1/4.

No. 12: bowl, Inv. No. C-0521 [064]

Uncoated	Nile B ₂	W ₂
----------	---------------------	----------------

Rim fragment; incurved walls, inverted articulated exterior rim, modelled lip. Rd: 12.00 cm 1/8; Wd: 0.60 cm; H₁: 3.00 + x cm. Throwing lines outside and inside; smoothed on the wheel.

No. 13: bowl (Fig. 40:3), Inv. No. C-0084 [005]

Uncoated	Nile B ₂	W ₂
----------	---------------------	----------------

Rim sherd; incurved walls, inverted articulated interior and exterior rim, trimmed lip. Rd: 20.00 cm 1/8; Wd: 0.60 cm; H₁: 5.50 + x cm. Throwing lines outside and inside; smoothed on the wheel. Another, Nile C₂, Rd: 36.00 cm 3/32.

No. 14: bowl (Fig. 40:3), Inv. No. C-0020 [003]

Uncoated	Nile B ₂	W ₂
----------	---------------------	----------------

Rim sherd; inverted articulated interior and exterior rim, flattened lip. Rd: 20.00 cm 3/32; Wd: 0.60 cm; H₁: 2.10 + x cm. Throwing lines outside and inside; smoothed on the wheel. Another, Rd: 18.00 cm 5/32.

No. 15: bowl, Inv. No. C-0015 [014]

Uncoated	Nile B ₂	W ₂
----------	---------------------	----------------

Rim sherd; inverted direct rim. Rd: 18.00 cm 1/16; Wd: 0.70 cm; H₁: 3.40 + x cm. Throwing lines outside; smoothed on the wheel. Others, Rd: 15.00 cm 1/4, Rd: 20.00: 1/4. Nile C₂, Rd: 22.00 cm 1/32.

No. 16: bowl?, Inv. No. C-0521 [169]

Uncoated	Nile B ₂	W ₂
----------	---------------------	----------------

Rim sherd; inverted modelled rim. Rd: 14.00 cm 3/32; Wd: 0.80 cm; H₁: 3.50 + x cm. Throwing lines outside; smoothed on the wheel.

No. 17: bowl, Inv. No. C-0379 [026]

Uncoated	Nile B ₂	W ₂
----------	---------------------	----------------

Rim sherd; inverted articulated exterior rim, round lip. Rd: 18.00 cm 1/16; Wd: 0.70 cm; H₁: 2.30 + x cm. Throwing lines outside and inside; smoothed on the wheel; eroded rim outside.

No. 18: bowl (Fig. 40:3), Inv. No. C-0135 [005]

Uncoated	Nile B ₂	W ₂
----------	---------------------	----------------

Rim sherd; inverted articulated interior rim, trimmed lip. Rd: 20.00 cm 1/8; Wd: 1.00 cm; H₁: 6.90 + x cm. Throwing lines outside and inside; three incised lines on the exterior; smoothed on the wheel.

No. 19: bowl (Fig. 40:3), Inv. No. C-0380 [088]Uncoated Nile B₂ W₂

Rim sherd; inverted articulated interior rim, flattened lip. Rd: 10.00 cm $\frac{3}{32}$; Wd: 0.50 cm; H₁: 1.60 + x cm. Smoothed on the wheel; eroded inside.

No. 20: bowl, Inv. No. C-0084 [003]Uncoated Nile B₂ W₂

Rim sherd; incurved walls, inverted articulated exterior rim, round lip. Rd: 20.00 cm $\frac{1}{8}$; Wd: 0.60 cm; H₁: 6.10 + x cm. Throwing lines outside and inside; smoothed on the wheel.

No. 21: bowl, Inv. No. C-0521 [101]Uncoated Nile B₂ W₂

Rim sherd; incurved walls, inverted articulated exterior rim, modelled lip. Rd: 12.00 cm $\frac{1}{8}$; Wd: 0.60 cm; H₁: 3.00 + x cm. Throwing lines outside and inside; smoothed on the wheel.

No. 22: bowl (Fig. 40:3), Inv. No. C-0521 [167]Uncoated Nile B₂ W₂

Rim sherd; vertical modelled rim. Rd: 30.00 cm $\frac{1}{16}$; Wd: 0.70 cm; H₁: 5.80 + x cm. Throwing lines outside and inside; smoothed on the wheel.

No. 23: bowl (Fig. 40:3), Inv. No. C-0521 [052]Uncoated Nile B₂ W₂

Rim sherd; incurved walls, everted direct rim, flattened. Rd: 28.00 cm $\frac{1}{8} + \frac{1}{32}$; Wd: 0.90 cm; H₁: 4.00 + x cm. Throwing lines outside and inside; smoothed on the wheel. Another, Rd: 28.00 cm $\frac{1}{4}$.

No. 24: bowl (Fig. 40:3), Inv. No. C-0521 [056]Uncoated Nile B₂ W₂

Rim sherd; everted direct rim. Rd: 20.00 cm $\frac{1}{36}$; Wd: 0.60 cm; H₁: 4.30 + x cm. Throwing lines outside and inside; smoothed on the wheel.

No. 25: bowl (Fig. 40:3), Inv. No. C-0521 [054]Uncoated Nile B₂ W₂

Rim sherd; incurved walls, everted articulated exterior rim, modelled lip. Rd: 24.00 cm $\frac{1}{16}$; Wd: 0.70 cm; H₁: 1.70 + x cm. Throwing lines outside and inside; smoothed on the wheel. Others, Nile B₂ Rd: 24.00 cm $\frac{1}{16}$. Nile E₁, Rd: 22.00 cm $\frac{1}{16}$.

No. 26: bowl (Fig. 40:3), Inv. No. C-0378 [009]Uncoated Nile B₂ W₂

Rim sherd; incurved walls; everted articulated interior and exterior rim, modelled lip. Rd: 22.00 cm $\frac{1}{8}$; Wd: 0.60 cm; H₁: 4.80 + x cm. Throwing lines outside; smoothed on the wheel; salt incrustated. Another, Rd: 32.00 cm $\frac{1}{16}$.

No. 27: bowl, Inv. No. C-0013 [001]Uncoated Nile C₁ W₂

Rim sherd; everted direct rim, round lip. Rd: 40.00 cm $\frac{1}{8}$; Wd: 1.30 cm; H₁: 4.10 + x cm. Throwing lines inside; smoothed on the wheel; eroded outside. Others, Nile B₂, Rd: 20.00 cm $\frac{3}{32}$, Rd: 20.00 cm $\frac{3}{32}$. Nile C₂, Rd: 24.00 cm $\frac{3}{32}$.

No. 28: bowl (Fig. 40:3), Inv. No. C-0020 [002]

Uncoated	Nile B ₂	W ₂
----------	---------------------	----------------

Rim sherd; flaring walls, everted direct rim, beveled lip. Rd: 34.00 cm 1/6; Wd: 0.40-0.70 cm; H₁: 4.00 + x cm. Throwing lines outside; smoothed on the wheel.

No. 29: bowl (Fig. 40:4), Inv. No. C-0521 [177]

Uncoated	Nile B ₂	W ₂
----------	---------------------	----------------

Rim sherd; everted direct rim, flattened inside. Rd: 38.00 cm 1/32; Wd: 1.50 cm; H₁: 8.00 + x cm. Throwing lines outside and inside; smoothed on the wheel.

No. 30: bowl (Fig. 40:4), Inv. No. C-0521 [170]

Uncoated	Nile B ₂	W ₂
----------	---------------------	----------------

Rim sherd; everted modelled rim, trimmed lip. Rd: 30.00 cm 3/32; Wd: 0.90 cm; H₁: 3.90 + x cm. Throwing lines outside; smoothed on the wheel.

No. 31: bowl (Fig. 40:4), Inv. No. C-0374 [001]

Uncoated	Nile B ₂	W ₂
----------	---------------------	----------------

Rim sherd; everted articulated exterior rim, trimmed lip. Rd: 24.00 cm 1/16; Wd: 0.70 cm; H₁: 3.40 + x cm. Throwing lines outside and inside; smoothed on the wheel. Another, Rd 20.00 cm 1/16.

No. 32: bowl (Fig. 40:4), Inv. No. C-0613 [002]

Uncoated	Nile B ₂	W ₂
----------	---------------------	----------------

Rim sherd; everted articulated exterior rim, pendant lip. Rd: 26.00 cm 3/32; Wd: 0.60 cm; H₁: 2.60 + x cm. Throwing lines inside outside and inside; smoothed on the wheel.

No. 33: bowl (Fig. 40:4), Inv. No. C-0378 [014]

Uncoated	Nile C ₂	W ₂
----------	---------------------	----------------

Rim sherd; everted articulated interior and exterior rim, trimmed lip. Rd: 32.00 cm 1/8; Wd: 1.00 cm; H₁: 3.70 + x cm. Throwing lines inside outside and inside; smoothed on the wheel; eroded. Others, Nile C₁, Rd: 20.00 cm 3/32, Rd: 30.00 cm 3/32, Rd: 32.00 cm 1/8, Rd: 38.00 cm 1/16. Nile C₂, Rd: 42.00 cm 1/8.

No. 34: bowl (Fig. 40:4), Inv. No. C-0521 [063]

Uncoated	Nile B ₂	W ₂
----------	---------------------	----------------

Rim fragment; everted articulated exterior rim, modelled lip. Rd: 40.00 cm 1/16; Wd: 1.20 cm; H₁: 4.30 + x cm. Throwing lines inside outside and inside; smoothed on the wheel. Others, Rd: 16.00 cm 1/16. Nile C₁, Rd: 18.00 cm 1/32, Rd: 20.00 cm 1/16. Nile E₁, Rd: 20.00 cm 3/32.

No. 35: bowl (Fig. 40:4), Inv. No. C-0521 [083]

Uncoated	Nile B ₂	W ₂
----------	---------------------	----------------

Rim sherd; everted articulated interior rim, modelled lip. Rd: 18.00 cm 3/32; Wd: 0.70 cm; H₁: 3.10 + x cm. Throwing lines inside outside and inside; smoothed on the wheel.

No. 36: bowl (Fig. 40:4), Inv. No. C-0614 [008]

Uncoated	Nile B ₂	W ₂
----------	---------------------	----------------

Rim sherd; everted articulated exterior rim, trimmed lip. Rd: 36.00 cm 7/32; Wd: 1.20 cm; H₁: 3.00 + x cm. Throwing lines outside and inside; smoothed on the wheel. Others, Rd: 32.00 cm 1/16. Nile E₁, Rd: 42.00 cm 1/32.

No. 37: bowl, Inv. No. C-0014 [004]

Uncoated	Nile B ₂	W ₂
----------	---------------------	----------------

Rim sherd; everted articulated exterior rim, round lip. Rd: 22.00 cm 1/8; Wd: 0.60 cm; H₁: 3.17 + x cm. Throwing lines outside and inside; smoothed on the wheel. Others, Rd: 18.00 cm 1/8, Rd: 20.00 cm 3/64, Rd: 22.00 cm 1/16, Rd: 24.00 cm 1/16, Rd: 30.00 cm 3/32, Rd: 32.00 cm 3/32. Nile C₁, Rd: 48.00 cm 1/16.

No. 38: bowl, Inv. No. C-0290 [002]

Uncoated	Nile B ₂	W ₂
----------	---------------------	----------------

Rim sherd; everted articulated interior rim, round lip. Rd: 30.00 cm 3/32; Wd: 0.60 cm; H₁: 4.45 + x cm. Throwing lines outside; smoothed on the wheel.

No. 39: bowl (Fig. 40:4), Inv. No. C-0006 [025]

Uncoated	Nile E ₂	W ₂
----------	---------------------	----------------

Rim sherd; everted articulated interior and exterior rim, modelled lip. Rd: 26.00 cm 1/16; Wd: 0.80 cm; H₁: 1.90 + x cm. Throwing lines outside and inside; smoothed on the wheel; eroded. Another, Nile C₂. Rd: 36.00 cm 3/32.

No. 40: bowl, Inv. No. C-0613 [005]

Uncoated	Nile B ₂	W ₂
----------	---------------------	----------------

Rim sherd; everted articulated interior and exterior rim, round lip. Rd: 30.00 cm 1/32; Wd: 0.90 cm; H₁: 2.97 + x cm. Throwing lines outside and inside; smoothed on the wheel; eroded. Others, Rd: 22.00 cm 1/16. Nile B₂/C₁, Rd: 14.00 cm 1/16.

No. 41: bowl (Fig. 40:4), Inv. No. C-0135 [001]

Uncoated	Nile B ₂	W ₂
----------	---------------------	----------------

Rim sherd; everted articulated interior and exterior rim, pendant lip. Rd: 22.00 cm 5/32; H₁: 2.80 + x cm. Throwing lines outside and inside; smoothed on the wheel.

No. 42: bowl (Fig. 40:4), Inv. No. C-0521 [187]

Uncoated	Nile B ₂	W ₂
----------	---------------------	----------------

Rim fragment; everted articulated interior and exterior rim, trimmed lip. Rd: 26.00 cm 1/32; Wd: 1.00 cm; H₁: 3.00 + x cm. Throwing lines outside; smoothed on the wheel. Another, Rd 20.00 cm 1/32.

No. 43: bowl (Fig. 40:4), Inv. No. C-0521 [037]

Uncoated	Nile C ₁	W ₂
----------	---------------------	----------------

Rim sherd; everted articulated symmetrical rim Rd: 30.00 cm 1/8; Wd: 1.00 cm; H₁: 4.20 + x cm; throwing lines outside and inside; smoothed on the wheel.

No. 44: bowl (Fig. 40:4), Inv. No. C-0380 [012]

Uncoated	Nile B ₂	W ₂
----------	---------------------	----------------

Rim sherd; everted articulated exterior rim. Rd: 28.00 cm 3/32; Wd: 0.90 cm; H₁: 1.90 + x cm. Smoothed on the wheel; eroded outside.

No. 45: bowl, Inv. No. C-0014 [002]

Uncoated	Nile B ₂ f.	W ₂
----------	------------------------	----------------

Rim sherd; everted articulated exterior rim, round lip. Rd: 24.00 cm 1/16; Wd: 0.60 cm; H₁: 3.50 + x cm. Throwing lines outside and inside; smoothed on the wheel. Others, Nile B₂/C₁, Rd: 22.00 cm 1/6.

No. 46: bowl (Fig. 40:4), Inv. No. C-0521 [180]

Uncoated	Nile C ₁	W ₂
----------	---------------------	----------------

Rim sherd; everted thickened rim, flat rim. Rd: 30.00 cm 3/32; Wd: 1.30 cm; H₁: 3.80 + x cm. Throwing lines outside; smoothed on the wheel; eroded.

No. 47: bowl (Fig. 40:4), Inv. No. C-0521 [061]

Uncoated	Nile C ₂	W ₂
----------	---------------------	----------------

Rim sherd; everted articulated interior rim, trimmed lip. Rd: 45.00 cm 3/32; Wd: 0.70 cm; H₁: 4.50 + x cm. Throwing lines outside and inside; smoothed on the wheel.

No. 48: bowl (Fig. 40:4), Inv. No. C-0001 [010]

Uncoated	Nile C ₂	W ₂
----------	---------------------	----------------

Rim sherd; everted articulated interior rim. Rd: 32.00 cm 1/16; Wd: 1.15 cm; H₁: 2.30 + x cm. Throwing lines outside and inside; smoothed on the wheel; smoked.

No. 49: bowl (Fig. 40:5), Inv. No. P7060A (Drawing No. 0014)

Uncoated	Nile B ₂	W ₁	---	ox.	2
----------	---------------------	----------------	-----	-----	---

Rim sherd; decorated rim; everted articulated rim, pendant lip. Rd: 24.00 cm 1/8; Wd: 0.80 cm; H₁: 2.50 + x cm. Surface colour: 2.5YR 6/4 light reddish brown. Break: 5YR 4/4 reddish brown core; 2.5YR 5/4 reddish brown oxidation zones. Decoration: modelled. Surface treatment: smoothed on the wheel. Eroded. *Find No. 004.*

No. 50: bowl (Fig. 40:5), Inv. No. C-0521 [019]

Uncoated	Nile B ₂	W ₂
----------	---------------------	----------------

Rim fragment; everted direct rim. Rd: 22.00 cm 1/16; Wd: 0.90 cm; H₁: 2.30 + x cm. Throwing lines inside; smoothed on the wheel.

Others, Rd 16.00-26.00 cm: 3 bowls, Rd: 20.00 cm 1/16, Rd: 26.00 cm 1/8, Rd: 40.00 cm 1/16, Rd: 45.00 cm 1/32. Nile B₁, Rd: 22.00 cm 1/16. Nile B₂/C₁, Rd: 40.00 cm 1/32. Nile C₁, Rd: 18.00 cm 1/32, Rd: 22.00 cm 1/8, Rd: 24.00 cm 1/8, Rd: 26.00 cm 1/16, Rd: 40.00 cm 1/4. Nile C₂, Rd: 26.00 cm 1/16, Rd: 34.00 cm 3/32, Rd: 42.00 cm 1/32, Rd: 50.00 cm 1/16, Rd: 44.00 cm 3/32. Nile E₁, Rd: 22.00 cm 3/32. Nile E₂, Rd: 18.00 cm 1/16, Rd: 30.00 cm 1/16, Rd: 34.00 cm 3/32.

No. 51: large bowl (Fig. 40:5), Inv. No. P0841A (Drawing No. 0901)

Uncoated	Nile C ₂	W ₁	---	ox.	2
----------	---------------------	----------------	-----	-----	---

Rim sherd; decorated rim. Rd: ca. 40.00 cm 1/16; Wd: 1.10 cm; H₁: 3.00 + x cm. Surface colour: 2.5YR 5/6 red. Break: 5YR 4/4 reddish brown core; 2.5YR 5/4 reddish brown oxidation zones. Decoration: modelled. Surface treatment: smoothed on the wheel. Eroded.

No. 52: large bowl (Fig. 40:5), Inv. No. P1012A (Drawing No. 0097)

Uncoated	Nile C ₂	W ₂	---	ox.	2
----------	---------------------	----------------	-----	-----	---

Rim sherd. Rd: 45.00 cm 1/8; Md: 0.95 cm; Wd: 1.00 cm; H₁: 6.50-7.00 + x cm. Surface colour: 10R 6/6 light red. Break: 2.5YR 5/4 reddish brown core; 2.5YR 5/8 red oxidation zones. Technical details: throwing lines inside. Decoration: modelled on the rim. Surface treatment: smoothed. Observations: eroded.

No. 53: bowl?, Inv. No. C-0003 [016]

Uncoated	Nile C ₂ c.	W ₂	W
----------	------------------------	----------------	---

Base fragment; flat base. Bd: 5.00 cm 1/2; Wd: 0.90 cm; H₁: 2.95 + x cm. Throwing lines outside and inside; smoothed on the wheel. Another, Nile C₁, Bd: 8.00 cm 1/32.

No. 54: bowl (Fig. 40:5), Inv. No. P0634A (Drawing No. 0379)

Uncoated	Nile B ₂ v.s.	W ₂	base finished on the wheel	ox.	2
----------	--------------------------	----------------	----------------------------	-----	---

Base fragment; ring base (R₃). Bd: 6.00 cm 1/4; Wd: 0.50 cm; H₁: 2.30 + x cm. Surface colour: 2.5YR 5/6 red. Break: 2.5YR 4/8 red. Technical details: throwing lines inside. Surface treatment: smoothed on the wheel. Others, Nile B₂, Bd: 8.00 cm 3/4, Bd: 9.00 cm 1/4. Nile C₁/C₂, Bd: 14.00 cm 1/4. Nile C₂, Bd: 12.00 cm 7/32, Bd: 13.00 cm 1/1, Bd: 16.00 5/32. Nile E₂, Rd: 10.00 cm 1/8.

No. 55: bowl, Inv. No. C-0380 [098]

Uncoated	Nile B ₂	W ₂	W
----------	---------------------	----------------	---

Base fragment; round base. Wd: 1.20 cm; H₁: 2.40 + x cm. Throwing lines outside and inside; smoothed on the wheel; eroded outside. Others: 4 bases.

No. 56: bowl, Inv. No. C-0269 [002]

Uncoated	Nile B ₂	W ₂	base finished on the wheel
----------	---------------------	----------------	----------------------------

Base fragment; pointed base. Wd: 0.50 cm; H₁: 2.80 + x cm. Throwing lines outside and inside; smoothed on the wheel; salt incusted.

No. 57: carinated bowl, Inv. No. C-0014 [010]

Uncoated	Nile B ₂	W ₂
----------	---------------------	----------------

Rim sherd; carinated bowl, inverted articulated interior and exterior rim, round lip. Rd: 12.00 cm 3/32; Wd: 0.53 cm; H₁: 4.26 + x cm. Throwing lines outside; smoothed on the wheel.

No. 58: carinated bowl (Fig. 40:5), Inv. No. C-0380 [046]

Uncoated	Nile B ₂	W ₂
----------	---------------------	----------------

Rim fragment (reconstructed shape); carinated walls, vertical direct rim. Rd: 26.00 cm 3/32; Wd: 0.65 cm; H₁: 4.20 + x cm. Throwing lines outside; smoothed on the wheel; salt incusted outside. Others, Rd: 18.00-22.00 cm 3/8.

No. 59: carinated bowl (Fig. 40:6), Inv. No. C-0380 [095]

Uncoated	Nile E ₁	W ₂
----------	---------------------	----------------

Rim fragment (reconstructed shape); carinated walls, everted direct rim. Rd: 22.00 cm 1/8; Wd: 0.40 cm; H₁: 4.50 + x cm. Throwing lines outside; smoothed on the wheel.

No. 60: carinated bowl, Inv. No. C-0379 [030]

Uncoated	Nile B ₂	W ₂
----------	---------------------	----------------

Rim sherd; carinated walls, everted articulated exterior rim, modelled lip. Rd: 18.00 cm 1/16; Wd: 0.80 cm; H₁: 2.55 + x cm. Throwing lines outside and inside; smoothed on the wheel.

No. 61: carinated bowl (Fig. 40:6), Inv. No. C-0380 [074]

Uncoated	Nile C ₁	W ₂
----------	---------------------	----------------

Rim sherd; carinated walls, everted articulated interior rim, trimmed lip. Rd: 16.00 cm 1/16; Wd: 0.60 cm; H₁: 2.20 + x cm. Smoothed on the wheel; eroded inside.

No. 62: carinated bowl, Inv. No. C-0379 [005]

Uncoated	Nile C ₁	W ₂
----------	---------------------	----------------

Rim sherd; carinated walls, everted articulated exterior rim, trimmed lip. Rd: 22.00 cm 3/16; Wd: 0.75-1.00 cm; H₁: 3.60 + x cm. Throwing lines outside and inside; smoothed on the wheel; eroded outside.

No. 63: shallow bowl (Fig. 40:6), Inv. No. C-0521 [036]

Uncoated	Nile B ₂	W ₂
----------	---------------------	----------------

Rim sherd (reconstructed sherds); incurved walls; everted direct rim, flattened lip. Rd: 24.00 cm 1/8; Wd: 0.60 cm; H₁: 4.20 + x cm; throwing lines outside and inside; smoothed on the wheel. Another, Rd: 24.00 cm 3/64.

No. 64: shallow bowl (Fig. 40:6), Inv. No. C-0521 [021]

Uncoated	Nile B ₂	W ₂
----------	---------------------	----------------

Rim sherd; incurved walls, inverted direct rim. Rd: 12.00 cm 5/32; Wd: 0.75 cm; H₁: 3.50 + x cm; throwing lines outside and inside; smoothed on the wheel. Others, Rd: 12.00 cm 5/32; Rd: 12.00 cm 1/8.

No. 65: deep bowl (Fig. 40:6), Inv. No. C-0097 [003]

Uncoated	Nile B ₂	W ₂
----------	---------------------	----------------

Rim sherd; incurved wall; inverted articulated exterior rim, round lip. Rd: 12.00 cm 1/8; Wd: 0.70 cm; H₁: 4.50 + x cm. Throwing lines inside and outside; smoothed on the wheel.

No. 66: deep bowl (Fig. 40:6), Inv. No. C-0116 [005]

Uncoated	Nile B ₂	W ₂
----------	---------------------	----------------

Rim sherd; vertical direct rim. Rd: 12.00 cm 7/32; Wd: 0.40-0.70 cm; H₁: 6.20 + x cm. Throwing lines inside and outside; smoothed on the wheel.

No. 67: deep bowl (Fig. 40:6), Inv. No. P1219A (Drawing No. 0527)

Uncoated	Nile E ₂	W ₂	---	ox.	2
----------	---------------------	----------------	-----	-----	---

Rim and body sherd; mended; everted direct rim. Rd: 11.00 cm 1/16; Wd: 0.30 cm; H₁: 4.50 + x cm. Surface colour: 5YR 6/4 light reddish brown. Break: 5YR 6/4 light reddish brown. Technical details: throwing lines inside. Surface treatment: smoothed on the wheel.

No. 68: deep bowl (Fig. 40:6), Inv. No. C-0521 [161]

Uncoated	Nile B ₂	W ₂
----------	---------------------	----------------

Rim sherd; everted articulated exterior rim, beveled lip. Rd: 15.00 cm 3/32; Wd: 0.80 cm; H₁: 2.80 + x cm. Throwing lines inside and outside; smoothed on the wheel.

No. 69: deep bowl? (Fig. 40:6), Inv. No. C-0020 [001]

Uncoated	Nile C ₂	W ₂
----------	---------------------	----------------

Rim sherd; everted articulated interior rim, trimmed lip. Rd: 26.00 cm 1/16; Wd: 0.80 cm; H₁: 7.00 + x cm. Throwing lines inside and outside; smoothed on the wheel.

No. 70: deep bowl (Fig. 40:6), Inv. No. P0608A (Drawing No. 0267)

Uncoated?	Nile E ₁	W ₂	base finished on the wheel	ox.	2
-----------	---------------------	----------------	----------------------------	-----	---

Base fragment; pointed base. Wd: 0.50-0.70 cm; H₁: 3.50 + x cm. Surface colour: 10R 5/6 red (slip?). Break: 10R 6/6 red. Technical details: throwing lines inside and outside. Eroded; salt incrustated. Others, 1 base. Nile E₂, 1 base.

No. 71: deep bowl (Fig. 40:7), Inv. No. P0620A (Drawing No. 0378)

Uncoated	Nile E ₂	W ₁	[W]	ox.	2
----------	---------------------	----------------	-----	-----	---

[Base] and body fragment; [rounded base]. Wd: 0.50-0.70 cm; H₁: 5.80 + x cm. Surface colour: 2.5YR 6/6 light red. Break: 2.5YR 4/1 dark reddish grey core; 2.5YR 5/8 red oxidation zones. Technical details: throwing lines inside. Surface treatment: smoothed on the wheel.

No. 72: cup (Fig. 40:7), Inv. No. P0637A (Drawing No. 0380)

Uncoated	Nile B ₂	W ₂	---	ox.	2
----------	---------------------	----------------	-----	-----	---

Rim and body fragment; inverted direct rim. Rd: 8.00 cm 5/32; Wd: 0.50-0.70 cm; H₁: 8.50 cm; H₂: 3.00 cm. Surface colour: 2.5YR 6/6 light red. Break: 10R 4/6 red core; 5YR 5/8 yellowish red oxidation zones. Technical details: throwing lines inside. Eroded. Others, Rd: 8.00 cm 3/32, Rd: 8.00 cm 3/32, Rd: 8.00 cm 5/64, Rd: 10.00 cm 3/16, Rd: 10.00 cm 7/32. Nile E₂, Rd: 10.00 cm 3/32.

No. 73: cup, Inv. No. C-0039 [001]

Uncoated	Nile E ₂	W ₂
----------	---------------------	----------------

Rim sherd; inverted articulated interior and exterior rim, modelled lip. Rd: 8.00 cm 5/32; Wd: 0.50 cm; H₁: 3.20 + x cm. Throwing lines inside and outside; smoothed on the wheel.

No. 74: cup, Inv. No. C-0379 [008]

Uncoated	Nile B ₂	W ₂
----------	---------------------	----------------

Rim and body fragment; everted direct rim. Rd: 10.00 cm 3/32; Wd: 0.60 cm; H₁: 5.10 + x cm. Throwing lines inside and outside; smoothed on the wheel; salt incrustated outside; smoked.

No. 75: cooking pot? (Fig. 40:7), Inv. No. C-0521 [141]

Uncoated	Nile B ₂	W ₂
----------	---------------------	----------------

Rim and body fragment; inverted articulated exterior rim, trimmed lip. Rd: 19.00 cm 1/8; Wd: 1.00 cm; H₁: 9.60 + x cm. Throwing lines inside and outside; smoothed on the wheel; smoked outside, on the base. Another, Rd: 20.00 cm 3/32.

No. 76: cooking pot? Inv. No. C-0378 [021bis]

Uncoated	Nile B ₂	W ₂
----------	---------------------	----------------

Rim sherd; eroded.

No. 77: pilgrim flask (Fig. 40:7), Inv. No. P1173A (Drawing No. 0526)

RS	Nile C ₁	W ₂ + Ha ₂	---	ox.	2
----	---------------------	----------------------------------	-----	-----	---

Rim, neck, handle, and shoulder fragment; everted articulated exterior rim. Rd: 4.50 cm 1/2; Nd: 3.30 cm; Wd: 0.70 cm; H₁: 6.00 + x cm; H₄: 5.00 cm; Hd: 1.20 x 0.60 cm; oval in section; 2; single strap. Surface colour: 2.5YR 5/6 red slip. Break: 2.5YR 5/1 reddish grey core; 5YR 4/4 reddish brown oxidation zones. Technical details: throwing lines inside, on the rim; made in two halves which are then joined. Surface treatment: smoothed.

No. 78: pilgrim flask (Fig. 40:7), Inv. No. P0059A (Drawing No. 0225)

Uncoated	Nile E ₂	Ha ₂	---	ox.	2
----------	---------------------	-----------------	-----	-----	---

Rim, neck and one handle fragment; everted articulated exterior rim. Rd: 1.75 cm; Nd: 1.60 cm; Wd: 0.35 cm; H₁: 2.70 + x cm; Hd: 0.80 x 0.17 cm; 2; single strap. Surface colour: 5YR 6/4 light reddish brown. Break: 5YR 5/4 reddish brown. Surface treatment: smoothed. Smoked.

No. 79: pilgrim flask (Fig. 40:7), Inv. No. P0822A (Drawing No. 0529). Handles (3), neck and body fragment. Nd: 2.70 cm; H₁: 3.00 + x cm; Hd: 0.90 x 0.80 cm. Technical details: applied handle. Smoked. *Find No. 009.*

No. 80: juglet, Inv. No. C-0020 [009], Nile B₂, handle, Hd: 1.00 x 0.70 cm.

No. 81: jug (Fig. 40:7), Inv. No. P1243A (Drawing No. 0635)

Uncoated	Nile E ₂	W ₂ + Ha ₂	---	ox.	2
----------	---------------------	----------------------------------	-----	-----	---

Rim and handle fragment; inverted articulated interior rim; handle from the rim. Rd: 11.00 cm 1/16; Wd: 0.30 cm; H₁: 2.20 + x cm; Hd: 2.20 x 2.30 cm; 1; single strap. Surface colour: 7.5YR 6/3 light brown. Break: 2.5YR 5/1 reddish grey core; 2.5YR 4/6 red oxidation zones. Technical details: throwing lines outside and inside. Surface treatment: smoothed.

No. 82: jug (Fig. 40:7), Inv. No. P0134A (Drawing No. 0380)

Uncoated	Nile B ₂	W ₁	---	ox.	2
----------	---------------------	----------------	-----	-----	---

Rim sherd; everted articulated exterior rim. Rd: 5.00 cm 1/4; Wd: 0.30 cm; H₁: 1.82 + x cm. Surface colour: 2.5YR 6/4 weak red. Break: 5YR 6/4 light reddish brown core; 2.5YR 6/8 red oxidation zones. Surface treatment: smoothed on the wheel.

No. 83: long-necked jar (Fig. 40:7), Inv. No. C-0521 [058]

Uncoated	Nile B ₂	W ₂			
----------	---------------------	----------------	--	--	--

Rim, neck and shoulder fragment; everted direct rim. Rd: 16.00 cm 1/32; Wd: 0.70 cm; H₁: 8.00 + x cm; H₃: 5.10 cm. Throwing lines inside; smoothed on the wheel. Another, Rd: 16.00 cm 1/32.

No. 84: jar (Fig. 40:8), Inv. No. P0164A (Drawing No. 0084)

Uncoated	Nile B ₂	W ₁	---	ox.	2
----------	---------------------	----------------	-----	-----	---

Rim and body sherd; globular shape; inverted modelled rim. Rd: 9.00 cm 3/16; Wd: 0.40 cm; H₁: 6.00 + x cm. Surface colour: 10R 6/6 light red. Break: 10R 5/8 red. Technical details: throwing lines inside. Surface treatment: smoothed on the wheel..

No. 85: jar (Fig. 40:8), Inv. No. P0223A (Drawing No. 0197)

Uncoated	Nile B ₁	W ₁	---	ox.	2
----------	---------------------	----------------	-----	-----	---

Rim and body fragment; slender shape; vertical compound rim. Rd: 10.00 cm 1/8; Md: 12.00 + x cm?; Wd: 0.50 cm; H₁: 7.00 + x cm. Surface colour: 2.5YR 5/8 red. Break: dark grey core; 2.5YR 5/6 red oxidation ones. Decoration: ribbed body. Surface treatment: smoothed on the wheel. Smoked.

No. 86: jar (Fig. 40:8), Inv. No. P0614A (Drawing No. 0379)

Uncoated	Nile C ₁	W ₂	---	ox.	2
----------	---------------------	----------------	-----	-----	---

Rim and body sherd; compound rim. Rd: 10.00 cm 7/32; Wd: 0.90-1.00 cm; H₁: 11.50 + x cm. Surface colour: 2.5YR 6/6 light red. Break: 10R 5/4 weak red core; 10R 3/2 dusky red and 10R 5/8 red oxidation ones. Technical details: throwing lines inside. Surface treatment: smoothed. Smoked; salt incusted.

No. 87: jar (Fig. 40:8), Inv. No. P0615A (Drawing No. 0380)

Uncoated	Nile B ₂	W ₂ + Ha ₂	---	ox.	2
----------	---------------------	----------------------------------	-----	-----	---

Rim, body and handle fragment; inverted articulated exterior rim, modeled lip. Rd: 10.00 cm 3/32; Wd: 0.70 cm; H₁: 5.50 + x cm; Hd: 1.90 x 1.20 cm; single strap. Surface colour: 10R 6/6 light red. Break: 10R 4/8 red. Technical details: throwing lines inside; applied handle from the rim to the shoulder. Surface treatment: smoothed on the wheel. Salt incusted.

No. 88: jar, Inv. No. C-0117 [018]

Uncoated	Nile B ₂	W ₂			
----------	---------------------	----------------	--	--	--

Neck and body fragment; globular shape. Wd: 0.70 cm; H₁: 8.80 + x cm. Throwing lines inside; smoothed on the wheel. Another, 1/1.

No. 89: jar, Inv. No. C-0039 [007]Uncoated Nile B₂ W₂

Rim and body fragment; globular shape, slightly everted articulated exterior rim, round lip. Rd: 18.00 cm 1/32; Wd: 0.80 cm; H₁: 7.80 + x cm. Throwing lines inside; smoothed on the wheel; salt incrustated inside, eroded.

No. 90: jar, Inv. No. C-0379 [006]Uncoated Nile C₂ W₂

Rim and shoulder fragment; globular shape, vertical direct rim. Rd: 12.00 cm 1/8; Wd: 1.20 cm; H₁: 6.70 + x cm. Throwing lines inside; smoothed on the wheel; eroded and salt incrustated inside. Another, Rd: 8.00 cm 1/2.

No. 91: jar (Fig. 40:8), Inv. No. C-0376 [004]Uncoated Nile B₂ W₂

Rim sherd; globular shape; everted direct rim. Rd: 10.00 cm 3/16; Wd: 0.60-1.00 cm; H₁: 5.50 + x cm. Throwing lines inside; smoothed on the wheel.

No. 92: jar (Fig. 40:8), Inv. No. C-0378 [002]Uncoated Nile B₂ W₂

Rim sherd; globular shape; inverted modelled rim. Rd: 14.00 cm 3/16; Wd: 0.63 cm; H₁: 6.30 + x cm. Throwing lines inside; smoothed on the wheel; eroded and salt incrustated inside.

No. 93: jar (Fig. 40:8), Inv. No. C-0380 [014]Uncoated Nile B₂ W₂

Rim sherd; vertical direct rim. Rd: 9.00 cm 7/32; Wd: 0.40-0.90 cm; H₁: 5.85 + x cm. Throwing lines inside; smoothed on the wheel. Others, Nile B₂, Rd: 8.00 cm 5/32, Rd: 9.00 cm 1/2, Rd: 10.00 cm 1/1, Rd: 11.00 cm 3/32, Rd: 12.00 cm 1/1, Rd: 13.00 cm 1/16, Rd: 14.00 cm 1/1, Rd: 16.00 cm 1/2. Nile C₁, Rd: 14.00 cm 1/8, Rd: 10.00 cm 1/2. Nile E₁, Rd: 10.00 cm 1/16. Nile E₂, Rd: 15.00 cm 5/64.

No. 94: jar (Fig. 40:8), Inv. No. C-0040 [001]Uncoated Nile C₁ W₂

Rim sherd; vertical articulated exterior rim, modelled lip. Rd: 19.00 cm 5/32; Wd: 0.90 cm; H₁: 5.20 + x cm. Throwing lines inside; smoothed on the wheel. Others, Nile B₂, Rd: 16.00 cm 1/16. Nile C₂, Rd: 10.00 cm 5/32.

No. 95: jar (Fig. 40:8), Inv. No. C-0015 [006]Uncoated Nile B₂ W₂

Rim sherd; vertical articulated exterior rim, round lip. Rd: 16.00 cm 3/32; Wd: 0.70 cm; H₁: 4.50 + x cm. Throwing lines inside and outside; smoothed on the wheel; eroded. Others, Rd: 8.00 cm 1/16, Rd: 10.00 cm 3/32, Rd: 12.00 cm 1/8, Rd: 14.00 cm 1/16.

No. 96: jar (Fig. 40:8), Inv. No. C-0396 [002]Uncoated Nile B₂ v. s. W₂

Rim and wall fragment; everted direct rim. Rd: 12.00 cm 5/32; Wd: 0.45-0.70 cm; H₁: 6.40 + x cm. Throwing lines inside; smoothed on the wheel; eroded inside, smoked outside. Others, Nile B₂, Rd: 8.00 cm 1/1, Rd: 9.00 cm 3/16, Rd: 10.00 cm 3 jars, Rd: 12.00 cm 1/1, Rd: 14.00 cm 1/2, Rd: 16.00 cm 3/32. Nile C₁, Rd: 9.00 cm 3/32, Rd: 10.00 cm 3/32. Nile E₂, Rd: 11.00 cm 1/8, Rd: 16.00 cm 1/8. Nile B₂, red slipped, Rd: 8.00 cm 1/8, Rd: 10.00 cm 3/32.

No. 97: jar (Fig. 40:9), Inv. No. C-0521 [070]Uncoated Nile B₂ W₂

Rim sherd; everted direct rim, folded lip. Rd: 10.00 cm 1/8; Wd: 0.55 cm; H₁: 3.50 + x cm. Throwing lines inside; smoothed on the wheel.

No. 98: jar (Fig. 40:9), Inv. No. C-0378 [001]Uncoated Nile B₂ W₂

Rim sherd; inverted articulated interior and exterior rim, modelled lip. Rd: 10.00 cm 1/8; Wd: 0.45 cm; H₁: 3.30 + x cm. Throwing lines inside; smoothed on the wheel; smoked inside.

No. 99: jar (Fig. 40:9), Inv. No. C-0521 [045]Uncoated Nile B₂ W₂

Rim sherd; everted compound rim, modelled lip. Rd: 12.00 cm 3/16; Wd: 0.70 cm; H₁: 3.00 + x cm. Throwing lines inside; smoothed on the wheel.

No. 100: jar (Fig. 40:9), Inv. No. C-0521 [074]Uncoated Nile B₂ W₂

Rim sherd; everted direct rim, folded lip. Rd: 13.00 cm 1/16; Wd: 0.70 cm; H₁: 2.50 + x cm. Throwing lines inside; smoothed on the wheel. Another, Rd: 10.00 cm 1/8.

No. 101: jar (Fig. 40:9), Inv. No. C-0613 [006]Uncoated Nile B₂ W₂

Rim sherd; slightly everted modelled rim. Rd: 12.00 cm 5/32; Wd: 0.80 cm; H₁: 3.62 + x cm. Throwing lines inside; smoothed on the wheel.

No. 102: jar (Fig. 40:9), Inv. No. C-0380 [033]Uncoated Nile B₂ W₂

Rim sherd; everted articulated exterior rim, round lip.; Wd: 0.70 cm; H₁: 6.10 + x cm. Throwing lines inside; smoothed on the wheel; salt incrustated on the rim. Others, Rd: 10.00 cm 1/2, Rd: 12.00 cm 1/8, Rd: 14.00 cm 5/32, Rd: 16.00 cm 3/32. Nile C₁, Rd: 14.00 cm 1/8; Nile E₂, Rd: 12.00 cm 1/8.

No. 103: jar (Fig. 40:9), Inv. No. C-0521 [013]Uncoated Nile B₂ W₂

Rim sherd; everted articulated exterior rim, trimmed lip. Rd: 16.00 cm 5/32; Wd: 1.00 cm; H₁: 5.50 + x cm. Throwing lines inside; smoothed on the wheel; eroded inside.

No. 104: jar, Inv. No. C-0040 [002]Uncoated Nile B₂ W₂

Rim sherd; everted articulated exterior rim, modelled lip. Rd: 14.00 cm 5/32; Wd: 0.60 cm; H₁: 3.75 + x cm. Throwing lines inside; smoothed on the wheel, eroded. Others, Rd: 8.00 cm 3/16, Rd: 10.00 cm 3/8. Nile C₁, Rd: 10.00 cm 3/32. Nile C₂, Rd: 12.00 cm 1/8, Rd: 16.00 cm.

No. 105: jar (Fig. 40:9), Inv. No. C-0521 [162]Uncoated Nile B₂ W₂

Rim sherd; everted articulated exterior rim. Rd: 12.00 cm 1/16; Wd: 1.15 cm; H₁: 2.90 + x cm. Throwing lines inside; smoothed on the wheel.

No. 106: jar (Fig. 40:9), Inv. No. C-0003 [001]

Uncoated	Nile B ₂ s.	W ₂
----------	------------------------	----------------

Rim and neck fragment; everted articulated exterior rim, modelled lip. Rd: 18.00 cm 1/8; Wd: 0.65 cm; H₁: 4.18 + x cm. Throwing lines inside; smoothed on the wheel; eroded. Another, Rd: 10.00 cm 1/16.

No. 107: jar, Inv. No. C-0379 [007]

Uncoated	Nile B ₂	W ₂
----------	---------------------	----------------

Rim sherd; everted articulated interior and exterior rim, trimmed lip. Rd: 14.00 cm 3/32; Wd: 0.60 cm; H₁: 2.20 + x cm. Throwing lines inside; smoothed on the wheel; eroded outside.

No. 108: jar (Fig. 40:9), Inv. No. C-0116 [011]

Uncoated	Nile B ₂	W ₂
----------	---------------------	----------------

Rim sherd; everted modelled rim. Rd: 10.00 cm 1/8; Wd: 0.30 cm; H₁: 2.30 + x cm. Throwing lines inside; smoothed on the wheel.

No. 109: jar (Fig. 40:9), Inv. No. C-0003 [011]

Uncoated	Nile B ₂	W ₂
----------	---------------------	----------------

Rim sherd; everted direct rim, round lip. Rd: 10.00 cm 5/32; Wd: 0.45 cm; H₁: 2.40 + x cm. Throwing lines inside and outside; smoothed on the wheel.

No. 110: jar (Fig. 40:9), Inv. No. C-0521 [174]

Uncoated	Nile B ₂	W ₂
----------	---------------------	----------------

Rim sherd; incurved walls, everted direct rim. Rd: 16.00 cm 3/32; Wd: 0.80 cm; H₁: 5.20 + x cm. Throwing lines inside; smoothed on the wheel. Another, Rd: 10.00 cm 3/32.

No. 111: jar (Fig. 40:9), Inv. No. C-0521 [178]

Uncoated	Nile B ₂	W ₂
----------	---------------------	----------------

Rim and neck fragment; modelled neck, everted direct rim. Rd: 15.00 cm 3/16; Wd: 0.80 cm; H₁: 5.00 + x cm. Throwing lines inside; smoothed on the wheel.

No. 112: jar (Fig. 40:9), Inv. No. C-0396 [008]

Uncoated	Nile E ₂	W ₂
----------	---------------------	----------------

Rim sherd; inverted direct rim. Rd: 12.00 cm 3/32; Wd: 0.70 cm; H₁: 3.65 + x cm. Throwing lines inside; smoothed on the wheel. Others, Rd: 10.00 cm 3/32, Rd: 12.00 cm 1/16. Nile B₂, Rd: 9.00 cm 3/32, Rd: 10.00 cm 3/8, Rd: 12.00 cm 1/8, Rd: 16.00 cm 3/32.

No. 113: jar (Fig. 40:9), Inv. No. C-0380 [076]

Uncoated	Nile B ₂	W ₂
----------	---------------------	----------------

Rim sherd; inverted articulated exterior rim, folded lip. Rd: 14.00 cm 3/32; Wd: 0.50 cm; H₁: 2.35 + x cm. Throwing lines inside; smoothed on the wheel; eroded.

No. 114: jar, Inv. No. C-0379 [017]

Uncoated	Nile B ₂	W ₂
----------	---------------------	----------------

Rim sherd; inverted modelled rim. Rd: 12.00 cm 3/32; Wd: 0.70 cm; H₁: 2.90 + x cm. Throwing lines inside; smoothed on the wheel; salt incrustated inside.

No. 115 : jar, Inv. No. C-0521 [041bis]

Uncoated	Nile B ₂	W ₂
----------	---------------------	----------------

Rim sherd; inverted articulated interior and exterior rim, modelled lip. Rd: 19.00 cm 1/16. Throwing lines inside; smoothed on the wheel.

No. 116: jar, Inv. No. C-0521 [033bis]

Uncoated	Nile B ₂	W ₂
----------	---------------------	----------------

Rim sherd; inverted direct rim. Rd: 12.00 cm 1/8; eroded.

No. 117: jar, Inv. No. C-0521 [039]

Uncoated	Nile B ₂	W ₂
----------	---------------------	----------------

Rim sherd; inverted articulated exterior rim, modelled lip. Rd: 14.00 cm 3/32; Wd: 0.70 cm; H₁: 4.00 + x cm. Throwing lines inside; smoothed on the wheel; eroded. Others, Rd: 6.00 cm 3/32, Rd: 10.00 cm 1/1. Nile C₂, Rd: 8.00 cm 5/32.

No. 118: jar (Fig. 40:9), Inv. No. C-0521 [008]

Uncoated	Nile B ₂	W ₂
----------	---------------------	----------------

Rim sherd; inverted articulated exterior rim, round lip. Rd: 9.00 cm 3/32; Wd: 0.60 cm; H₁: 5.50 + x cm. Throwing lines inside; smoothed on the wheel; eroded inside. Others, Rd: 10.00 cm 1/16. Nile C₁, Rd: 14.00 cm 3/16. Nile E₂ Rd: 8.00 cm 3/32, Rd: 14.00 cm 1/16, Rd: 16.00 cm 5/32.

No. 119: jar, Inv. No. C-0521 [041]

Uncoated	Nile B ₂	W ₂
----------	---------------------	----------------

Rim sherd; inverted articulated interior and exterior rim, modelled lip. Rd: 16.00 cm 1/16; Wd: 0.40 cm; H₁: 3.30 + x cm. Throwing lines inside; smoothed on the wheel. Another, Rd: 16.00 cm 1/16.

No. 120: jar (Fig. 40:10), Inv. No. C-0374 [002]

Uncoated	Nile B ₂	W ₂
----------	---------------------	----------------

Rim sherd; inverted articulated interior and exterior rim, trimmed lip. Rd: 10.00 cm 1/8; Wd: 0.60 cm; H₁: 4.20 + x cm. Throwing lines inside; smoothed on the wheel; salt incrustated inside.

No. 121: jar (Fig. 40:10), Inv. No. C-0521 [018]

Uncoated	Nile B ₂	W ₂
----------	---------------------	----------------

Rim sherd; inverted articulated interior rim, round lip. Rd: 10.00 cm 3/32; Wd: 0.40 cm; H₁: 5.00 + x cm. Throwing lines inside; smoothed on the wheel; eroded inside. Others, Rd: 9.00 cm 3/32. Nile E₂, Rd: 12.00 cm 1/16.

No. 122: jar (Fig. 40:10), Inv. No. C-0521 [082]

Uncoated	Nile B ₂	W ₂
----------	---------------------	----------------

Rim and shoulder sherd; inverted articulated interior rim, modelled lip. Rd: 16.00 cm 3/32; Wd: 0.40 cm; H₁: 2.30 + x cm. Throwing lines inside; smoothed on the wheel.

No. 123: jar (Fig. 40:10), Inv. No. C-0380 [006]

Uncoated	Nile B ₂	W ₂
----------	---------------------	----------------

Rim sherd; inverted flaring rim. Rd: 10.00 cm 1/8; Wd: 0.80 cm; H₁: 3.50 + x cm. Throwing lines inside; smoothed on the wheel; salt incrustated inside.

No. 124: jar (Fig. 40:10), Inv. No. C-0521 [128]

Uncoated	Nile B ₂	W ₂
----------	---------------------	----------------

Rim sherd; inverted articulated exterior rim, round lip. Rd: 14.00 cm 1/16; Wd: 0.70 cm; H₁: 4.50 + x cm. Throwing lines inside smoothed on the wheel. Others, Rd: 8.00 cm 1/2, Rd: 10.00 cm 1/2, Rd: 12.00 cm 1/1, Rd: 16.00 cm 3/32.

No. 125: jar, Inv. No. C-0396 [012]

Uncoated Nile B₂ W₂

Rim sherd; inverted direct rim. Rd: 10.00 cm 1/16; Wd: 0.70 cm; H₁: 5.20 + x cm. Throwing lines inside; smoothed on the wheel; eroded. Others, Rd: 7.00 cm 3/32, Rd: 8.00 cm 3/16, Rd: 10.00 cm 1/1, Rd: 12.00 cm 1/8, Rd: 14.00 cm 1/4.

No. 126: jar, Inv. No. C-0521 [033bis]

Uncoated Nile B₂ W₂

Rim sherd; undulated walls, inverted direct rim. Rd: 11.00 cm 1/8; eroded.

No. 127: jar (Fig. 40:10), Inv. No. C-0020 [005]

Uncoated Nile B₂ W₂

Rim and neck fragment; compound neck, inverted articulated exterior rim, round lip. Rd: 12.00 cm 1/8; Wd: 0.60-0.80 cm; H₁: 3.80 + x cm. Throwing lines inside; smoothed on the wheel. Another, Rd: 16.00 cm 5/32.

No. 128: jar (Fig. 40:10), Inv. No. C-0378 [008]

Uncoated Nile B₂ W₂

Rim sherd; inverted articulated interior and exterior rim, modelled lip. Rd: 12.00 cm 7/32; Wd: 0.70 cm; H₁: 2.50 + x cm. Throwing lines inside; smoothed on the wheel; eroded.

No. 129: jar (Fig. 40:10), Inv. No. C-0521 [179]

Uncoated Nile B₂ W₂

Rim sherd; inverted articulated exterior rim, folded lip. Rd: 20.00 cm 1/16; Wd: 1.00 cm; H₁: 5.00 + x cm. Throwing lines inside; smoothed on the wheel.

No. 130: jar, Inv. No. C-0014 [021]

Uncoated Nile B₂ W₂

Rim sherd; inverted articulated interior and exterior rim, round lip. Rd: 12.00 cm 3/32; Wd: 0.80 cm; H₁: 4.36 + x cm. Throwing lines inside; smoothed on the wheel. Another, Nile E₂, Rd: 9.00 cm 1/32.

No. 131: jar (Fig. 40:10), Inv. No. C-0084 [004]

Uncoated Nile B₂ W₂

Rim sherd; inverted articulated interior rim, trimmed lip. Rd: 16.00 cm 3/32; Wd: 0.70 cm; H₁: 3.57 + x cm. Throwing lines inside; smoothed on the wheel.

No. 132: jar (Fig. 40:10), Inv. No. C-0380 [040]

Uncoated Nile B₂ W₂

Rim sherd; vertical articulated exterior rim, pendant flattened lip. Rd: 14.00 cm 1/8; Wd: 0.80 cm; H₁: 3.10 + x cm. Throwing lines inside; smoothed on the wheel; eroded on the rim.

No. 133: jar (Fig. 40:10), Inv. No. C-0521 [163]

Uncoated Nile B₂ W₂

Rim sherd; vertical direct trim, trimmed. Rd: 18.00 cm 3/16; Wd: 1.10 cm; H₁: 8.00 + x cm. Throwing lines inside; smoothed on the wheel.

No. 134: jar (Fig. 40:10), Inv. No. C-0521 [171]

Uncoated Nile B₂ W₂

Rim sherd; vertical modelled rim. Rd: 18.00 cm 1/8; Wd: 0.70 cm; H₁: 5.00 + x cm.

Throwing lines inside; smoothed on the wheel.

No. 135: jar, Inv. No. C-0374 [008]

Uncoated	Nile C ₂	W ₂
----------	---------------------	----------------

Rim and shoulder fragment; vertical articulated interior and exterior rim, modelled lip. Rd: 10.00 cm 3/16; Wd: 0.55-0.65 cm; H₁: 3.90 + x cm. Throwing lines inside; smoothed on the wheel; eroded and salt incrustated rim.

No. 136: jar (Fig. 40:10), Inv. No. C-0001 [018]

Uncoated	Nile E ₂	W ₂
----------	---------------------	----------------

Rim sherd; everted articulated exterior rim, pendant lip. Rd: 18.00 cm 3/32; Wd: 1.30 cm; H₁: 2.60 + x cm. Smoothed on the wheel.

No. 137: jar, Inv. No. C-0135 [003]

Uncoated	Nile E ₂	W ₂
----------	---------------------	----------------

Rim sherd; inverted articulated interior and exterior rim, beveled lip. Rd: 10.00 cm 5/32; Wd: 0.80 cm; H₁: 3.40 + x cm. Throwing lines inside; smoothed on the wheel.

No. 138: jar (Fig. 40:10), Inv. No. P0635A (Drawing No. 0379)

Uncoated	Nile B ₂	W ₂	W	med.	2
----------	---------------------	----------------	---	------	---

Base; raised base. Bd: 4.80 cm 1/1; Wd: 0.80 cm; H₁: 2.00 + x cm. Surface colour: 2.5YR 6/6 red. Break: 2.5YR 4/2 weak red core; 2.5YR 5/6 red oxidation zones. Technical details: throwing lines outside and inside; eroded.

No. 139: jar (Fig. 40:10), Inv. No. P0513A (Drawing No. 0039)

Uncoated	Nile B ₂	W ₂	W	ox.	2-3
----------	---------------------	----------------	---	-----	-----

Base fragment; round base. Md: 11.00 + x cm; Wd: 1.50 cm; H₁: 3.20 + x cm. Surface colour: 2.5YR 5/4 weak red. Break: 10R 5/3 weak red. Technical details: throwing lines inside. Surface treatment: smoothed on the wheel. Salt incrustations.

No. 140: jar (Fig. 40:11), Inv. No. P0214A (Drawing No. 0213)

RS	Nile C ₂	W ₂	W	ox.	2
----	---------------------	----------------	---	-----	---

Incomplete; no rim preserved; round base; carinated walls. Md: 14.00 cm; Wd: 0.60 cm; H₁: 13.50 + x cm; H₂: 8.00 cm. Surface colour: 2.5YR 6/6 red slip. Break: 5YR 5/4 reddish brown. Technical details: deformed; throwing lines inside and outside. Surface treatment: smoothed on the wheel. Smoked outside. Others, Nile B₂, 5 bases.

No. 141: jar (Fig. 40:11), Inv. No. P0009A (Drawing No. 0212)

Uncoated	Nile E ₂	W ₂	base finished on the wheel	ox.	2
----------	---------------------	----------------	----------------------------	-----	---

Base fragment; ring base (R₃). Bd: 7.40 cm; Wd: 0.50 cm; H₁: 1.60 + x cm. Surface colour: 2.5YR 6/6 red. Break: 5YR 4/4 reddish brown core; 2.5YR 5/6 red oxidation zones. Technical details: throwing lines inside. Surface treatment: smoothed on the wheel. Others, Nile B₂, Bd: 5.00 cm 1/1, Bd: 10.00 cm 1/2.

No. 142: jar (Fig. 40:11), Inv. No. P1216A (Drawing No. 0628)

Uncoated	Nile E ₁	W ₂	base finished on the wheel	ox.	2
----------	---------------------	----------------	----------------------------	-----	---

Base fragment; pointed base. Md: ca. 7.60 cm; Wd: 0.80 cm; H₁: 4.50 + x cm. Surface colour: 7.5YR 6/3 light brown. Break: 7.5YR 5/3 brown core; 5YR 4/4 reddish brown oxidation zones. Technical details: throwing lines inside; grooves outside. Surface treatment: smoothed on the wheel. Others, Nile B₂, 10 bases. Nile E₂, 1 base.

No. 142bis: jar (Fig. 40:11), Inv. No. C-0521 [600]

Uncoated	Nile B ₂	W ₂	W
----------	---------------------	----------------	---

Base fragment, ½; disc base. Bd: 8.00 cm; Wd: 0.90 cm; H₁: 7.00 + x cm. Throwing lines inside; made in parts; eroded outside.

No. 143: jar (Fig. 40:11), Inv. No. P0161A (Drawing No. 0084)

RS	Nile B ₂	W ₁ + Ha ₂	---	ox.	2-3
----	---------------------	----------------------------------	-----	-----	-----

Body and handle fragment. Md: ca. 24.00 cm; Wd: 0.80 cm; H₁: 4.50 + x cm; Hd: 2.00 x 0.60 cm; single strap. Surface colour: 10R 4/6 red slip. Break: 10R 5/4 weak red core; 10R 5/3 weak red oxidation zones. Technical details: handle attached to the body; two grooves on the body; throwing lines inside. Surface treatment: smoothed on the wheel.

No. 144: pilgrim flask (Fig. 40:11), Inv. No. P0221A (Drawing No. 0186)

Uncoated	Nile B ₂	W ₂₁	---	ox.	2
----------	---------------------	-----------------	-----	-----	---

Neck fragment. Nd: 1.60 cm; Wd: 0.30 cm; H₃: 2.30+ x cm. Surface colour: 5YR 6/6 reddish yellow. Break: 10R 5/6 red. Technical details: made in two halves which are then joined. Surface treatment: smoothed.

No. 145: storage jar (Fig. 40:11), Inv. No. C-0380 [044]

Uncoated	Nile B ₂	W ₂
----------	---------------------	----------------

Rim sherd; everted articulated exterior rim, folded lip. Rd: 26.00 cm 3/32; Wd: 0.90 cm; H₁: 6.90 + x cm. Smoothed on the wheel; salt incrustated outside; eroded inside. Others, Rd: 22.00 cm 1/16, Rd: 22.00 cm 1/16.

No. 146: storage jar (Fig. 40:11), Inv. No. C-0521 [005]

Uncoated	Nile B ₂	W ₂
----------	---------------------	----------------

Rim sherd; flattened rim, everted direct rim. Rd: 28.00 cm 3/32; Wd: 1.10 cm; H₁: 5.70 + x cm. Throwing lines inside and outside; smoothed on the wheel on the wheel. Another, Rd: 22.00 cm 1/16.

No. 147: storage jar (Fig. 40:11), Inv. No. C-0614 [001]

Uncoated	Nile B ₂	W ₂
----------	---------------------	----------------

Rim sherd; everted articulated exterior rim, rolled lip. Rd: 22.00 cm 3/32; Wd: 1.50 cm; H₁: 9.60 + x cm. Throwing lines inside; smoothed on the wheel; eroded.

No. 148: storage jar (Fig. 40:12), Inv. No. C-0135 [008]

Uncoated	Nile B ₂	W ₂
----------	---------------------	----------------

Rim sherd; everted articulated exterior rim, rounded lip. Rd: 34.00 cm 5/32; Wd: 1.10 cm; H₁: 9.20 + x cm. Throwing lines inside; smoothed on the wheel. Others, Rd: 26.00 cm 1/16, Rd: 30.00 cm 1/8, Rd: 32.00 cm 3/16, Rd: 35.00 cm 1/8. Nile C₂, Rd: 32.00 cm 1/8, Rd: 34.00 cm 1/16, Rd: 50.00? cm 1/32.

No. 149: storage jar, Inv. No. C-0521 [024]

Uncoated	Nile B ₂	W ₂
----------	---------------------	----------------

Rim sherd; everted articulated exterior rim, folded lip. Rd: 30.00 cm 5/64; Wd: 1.20 cm; H₁: 7.20 + x cm. Throwing lines inside; smoothed on the wheel; eroded. Others, Rd: 20.00 cm 1/32. Nile C₁, Rd: 24.00 cm 1/16.

No. 150: storage jar (Fig. 40:12), Inv. No. C-0135 [007]

Uncoated	Nile B ₂	W ₂
----------	---------------------	----------------

Rim sherd; everted direct rim. Rd: 42.00 cm 3/32; Wd: 1.40 cm; H₁: 5.80 + x cm.

Throwing lines inside and outside; smoothed on the wheel.

No. 151: storage jar (Fig. 40:12), Inv. No. C-0006 [022]

Uncoated Nile C₂ W₂ + Ha₂

Rim and handle fragment; vertical loop handle applied to the rim; everted direct rim. Rd: 28.00 cm 3/32; Wd: 1.28 cm; H₁: 5.85 + x cm; Hd: 1.90 x 0.90 cm; oval in section; 1; single strap. Throwing lines inside and outside; smoothed on the wheel. Others, Nile B₂, Rd: 22.00 cm 3/32. Nile C₂, Rd: 26.00 cm 1/8.

No. 152: storage jar, Inv. No. C-0379 [040]

Uncoated Nile B₂ W₂

Rim sherd; inverted direct rim. Rd: 24.00 cm 3/32; Wd: 0.80 cm; H₁: 8.40 + x cm. Throwing lines inside and outside; smoothed on the wheel; eroded outside, salt incrustated inside. Others, Rd: 22.00 cm 1/8, Rd: 25.00 cm 1/16.

No. 153: storage jar (Fig. 40:12), Inv. No. C-0521 [159]

Uncoated Nile C₂ W₂ + Ha₂

Rim, body and handle fragment, attached from below the rim to the body vertical loop handle inverted, articulated exterior rim, folded lip. Rd: 31.00 cm 5/32; Wd: 1.50 cm; H₁: 13.50 + x cm; Hd: 2.30 x 2.10 cm; 1; single strap. Throwing lines inside and outside; fingerprints on the attachment; string marks, made in parts; smoothed. Another, Nile B₂, Rd: 24.00 cm 3/32.

No. 154: storage jar, Inv. No. C-0415 [001]

Uncoated Nile B₂ W₂

Rim sherd; inverted articulated exterior rim, modelled lip. Rd: 20.00 cm 1/8; Wd: 0.82 cm; H₁: 3.34 + x cm. Throwing lines inside and outside; smoothed on the wheel; eroded outside.

No. 155: storage jar (Fig. 40:12), Inv. No. C-0380 [045]

Uncoated Nile B₂/C₁ W₂

Rim sherd; inverted articulated interior and exterior rim. Rd: 20.00 cm 3/32; Wd: 1.20 cm; H₁: 4.40 + x cm. Throwing lines inside; smoothed on the wheel; eroded outside.

No. 156: storage jar, Inv. No. C-0015 [012]

Uncoated Nile B₂ W₂

Rim sherd; vertical articulated symmetrical rim, modelled lip. Rd: 24.00 cm 1/32; Wd: 0.80-1.00 cm; H₁: 4.60 + x cm. Throwing lines inside and outside; smoothed on the wheel.

No. 157: storage jar (Fig. 40:12), Inv. No. C-0374 [009]

Uncoated Nile B₂ W₂

Rim sherd; vertical direct rim. Rd: 24.00 cm 5/32; Wd: 1.15-1.30 cm; H₁: 8.10 + x cm. Throwing lines inside and outside; smoothed on the wheel. Others, Rd: 20.00 cm 1/4, Rd: 22.00 cm 1/2, Rd: 25.00 cm 1/4, Rd: 30.00 cm 1/32. Nile C₂, Rd: 30.00 cm 3/32, Rd: 32.00 cm 1/16.

No. 158: storage jar (Fig. 40:12), Inv. No. C-0378 [012]

Uncoated Nile B₂ W₂

Rim sherd; vertical articulated exterior rim, rounded lip. Rd: 32.00 cm 5/32; Wd: 0.80 cm; H₁: 5.50 + x cm. Throwing lines inside and outside; smoothed on the wheel. Others, Rd: 20.00 cm 3/32. Nile C₂, Rd: 30.00 cm 3/32.

No. 159: storage jar (Fig. 40:12), Inv. No. C-0116 [008]Uncoated Nile B₂/C₁ W₂

Rim sherd; inverted articulated exterior rim, rolled lip. Rd: 28.00 cm 1/32; Wd: 0.90 cm; H₁: 5.70 + x cm. Throwing lines inside and outside; smoothed on the wheel.

No. 159bis: storage jar (Fig. 40:12), Inv. No. C-0378 [021]Uncoated Nile B₂ W₂

Rim sherd; inverted articulated exterior rim, round lip. Rd: 26.00 cm 3/32; Wd: 1.40 cm; H₁: 5.10 + x cm. Throwing lines inside and outside; smoothed on the wheel; eroded rim inside.

No. 160: storage jar, Inv. No. C-0521 [049]Uncoated Nile C₂ W₂

Rim sherd; everted articulated symmetrical rim, folded lip. Rd: 40.00 cm 1/32; Wd: 1.20 cm; H₁: 5.50 + x cm. Throwing lines inside and outside; smoothed on the wheel. Others, Rd: 35.00 cm 1/32, Rd: 40.00 cm 1/32. Nile B₂, Rd: 35.00 cm 1/32.

No. 161: storage jar (Fig. 40:12), Inv. No. C-0380 [090]Uncoated Nile C₂ W₂

Rim sherd; inverted articulated interior and exterior rim, flattened lip. Rd: 34.00? cm 1/16; Wd: 1.20 cm; H₁: 6.00 + x cm. Throwing lines inside and outside; smoothed on the wheel.

No. 162: storage jar (Fig. 40:12), Inv. No. C-0380 [043]Uncoated Nile C₂ W₂

Rim sherd; inverted articulated exterior rim, modelled. Rd: 32.00 cm 3/32; Wd: 1.20 cm; H₁: 4.80 + x cm. Throwing lines inside; smoothed on the wheel; eroded. Others, Rd: 20.00 cm 1/16, Rd: 20.00 cm 1/16.

No. 163: storage jar, Inv. No. C-0290 [006]Uncoated Nile C₂ W₂

Rim sherd; inverted articulated exterior rim, irregular trimmed lip. Rd: 40.00 cm 1/16; Wd: 0.80-1.10 cm; H₁: 4.59 + x cm. Throwing lines inside and outside; smoothed on the wheel.

No. 164: storage jar? (Fig. 40:12), Inv. No. C-0380 [003]Uncoated Nile B₂ W₂

Rim sherd; inverted direct rim. Rd: 28.00 cm 3/32; Wd: 0.60-0.70 cm; H₁: 9.20 + x cm. Throwing lines inside; smoothed on the wheel; smoked outside. Others, Rd: 20.00 cm 1/16, Rd: 20.00 cm 1/16.

No. 165: storage jar, Inv. No. C-0521 [158]Uncoated Nile C₂ W₂

Rim, body and handle fragment, attached from below the rim to the body vertical loop handle; inverted articulated exterior rim, trimmed lip. Rd: 36.00 cm 1/8; Wd: 1.50 cm; H₁: 14.00 + x cm; Hd: 3.35 x 2.40 cm; irregular in section; 1; single strap. Throwing lines inside and outside, fingerprints on the attachment; smoothed on the wheel.

No. 166: storage jar (Fig. 40:12), Inv. No. C-0521 [150]Uncoated Nile C₂ W₂

Rim sherd; everted articulated exterior rim, flattened lip. Rd: 22.00 cm 1/16; Wd: 1.50 cm; H₁: 5.20 + x cm. Throwing lines inside; smoothed on the wheel; eroded inside.

No. 167: storage jar (Fig. 40:12), Inv. No. C-0521 [142]

Uncoated	Nile C ₁	W ₂	W
----------	---------------------	----------------	---

Base fragment; nipple base. Wd: 1.40 cm; H₁: 4.90 + x cm. Throwing lines inside and outside; smoothed on the wheel; eroded inside.

No. 168: storage jar, Inv. No. C-0521 [079]

Uncoated	Nile B ₂	W ₂ + Ha ₂
----------	---------------------	----------------------------------

Handle fragment; attached body to body vertical loop handle. H₁: 7.50 + x cm; Hd: 4.40 x 2.70 cm; single strap.

No. 169: amphora (Fig. 40:12), Inv. No. C-0521 [065]

Uncoated	Nile B ₂	W ₂
----------	---------------------	----------------

Rim sherd; vertical direct rim. Rd: 12.00 cm 3/16; Wd: 0.70 cm; H₁: 3.00 + x cm. Throwing lines inside and outside; smoothed on the wheel. Another, Rd: 12.00 cm 3/16.

No. 170: amphora (Fig. 40:12), Inv. No. C-0521 [069]

Uncoated	Nile B ₂	W ₂
----------	---------------------	----------------

Rim sherd; everted direct rim. Rd: 10.00 cm 1/2; Wd: 0.70 cm; H₁: 5.00 + x cm. Throwing lines inside and outside; smoothed on the wheel.

No. 171: amphora?, Inv. No. C-0003 [013]

Uncoated	Nile B ₂	W ₂
----------	---------------------	----------------

Rim sherd; vertical articulated rim, trimmed lip. Rd: 8.00 cm 3/32; Wd: 0.65 cm; H₁: 2.40 + x cm. Throwing lines inside and outside; smoothed; eroded.

No. 172: amphora (Fig. 40:13), Inv. No. C-0374 [013]

Uncoated	Nile B ₂	W ₂
----------	---------------------	----------------

Rim and shoulder fragment; "torpedo" type; vertical articulated exterior rim, round lip. Rd: 10.00 cm 1/16; Wd: 0.70 cm; H₁: 3.70 + x cm. Throwing lines inside and outside; smoothed on the wheel; eroded inside.

No. 173: amphora?, Inv. No. C-0374 [004]

Uncoated	Nile B ₂	W ₂
----------	---------------------	----------------

Rim sherd; inverted articulated interior and exterior rim, trimmed lip. Rd: 10.00 cm 3/16; Wd: 0.60 cm; H₁: 3.10 + x cm. Throwing lines inside and outside; smoothed; salt incrustated inside.

No. 174: amphora (Fig. 40:13), Inv. No. C-0521 [134]

Uncoated	Nile B ₂	W ₂
----------	---------------------	----------------

Neck and shoulder fragment; "torpedo" type. Md: 24.00 cm; Wd: 0.60 cm; H₁: 6.00 + x cm. Throwing lines inside and outside; smoothed on the wheel.

No. 175: amphora, Inv. No. C-0380 [103]

Uncoated	Nile B ₂	W ₂
----------	---------------------	----------------

Shoulder fragment. Md: 26.00 cm; Wd: 0.90 cm; H₁: 6.40 + x cm. Throwing lines inside; smoothed on the wheel; eroded inside.

No. 176: amphora, Inv. No. C-0117 [010]

Uncoated	Nile E ₂	W ₂ + Ha ₂
----------	---------------------	----------------------------------

Handle fragment; attached vertical loop handle. H₁: 8.60 + x cm; Hd: 2.50 x 1.20 cm; single strap. Surface treatment: smoothed; salt incrustated. Another, Nile B₂, Hd: 3.00 x

1.80 cm.

No. 177: handles (from jars and storage jars),

Nile B₂. Hd: 3.70 x 2.75 cm; Hd: 2.20 x 1.18 cm; Hd: 1.85 x 0.75 cm; Hd: 2.30 x 1.30; Hd: 2.80 x 1.90 cm; Hd: 3.30 x 2.10 cm; Hd: 3.10 x 2.08 cm; Hd: 3.80 x 2.00 cm; Hd: 2.40 x 1.40 cm; Hd: 3.90 x 2.40 cm; Hd: 3.60 x 2.00 cm; Hd: 3.70 x 1.75 cm; Hd: 2.70 x 1.70 cm; Hd: 4.00 x 2.10 cm; Hd: 5.00 x 2.70 cm; Hd: 3.50 x 2.60 cm; Hd: 2.70 x 2.30 cm; Hd: 3.80 x 2.60 cm; Hd: 3.10 x 2.10 x 1.60 cm, irregular in section; Hd: 4.60 x 2.90 cm; Hd: 3.60 x 2.65 cm; Hd: 2.30 x 1.85 cm; Hd: 3.00 x 2.30 cm; Hd: 2.40 x 1.80 cm; Hd: 3.48 x 2.10 x 1.50 cm, irregular in section.

Nile C₁, Hd: 4.00 x 2.30 cm Nile C₂, Hd: 3.80 x 2.60 cm; Hd: 2.50 x 1.50 cm; Hd: 3.30 x 2.25 cm.

Nile E₂, Hd: 2.80 x 1.60 cm; Hd: 2.13 x 1.42 cm; Hd: 1.80 x 1.10 cm; Hd: 2.55 x 1.85 x 1.30 cm irregular in section.

Pinched loop handle, Nile C₂, Hd: 1.85 x 0.72 cm, fingerprints on the handle.

Pottery with special functions

No. 178: lid, Inv. No. C-0377 [002]

Uncoated	Nile B ₂	W ₂
----------	---------------------	----------------

Rim sherd; everted direct rim. Rd: 18.00 cm 3/32; Wd: 0.80 cm; H₁: 2.10 + x cm. Throwing lines; smoothed on the wheel; smoked inside. Another, Rd: 20.00 cm 1/8.

No. 179: lid (Fig. 40:13), Inv. No. C-0521 [029]

Uncoated	Nile B ₂	W ₂
----------	---------------------	----------------

Rim and wall fragment; everted articulated exterior rim, round lip. Rd: 26.00 cm 3/4; Wd: 0.90 cm; H₁: 8.30 + x cm; throwing lines; smoothed on the wheel; smoked on the rim. Others, Rd: 23.00 cm 7/64, Rd: 26.00 cm 3/4.

No. 180: lid (Fig. 40:13), Inv. No. P7049A (Drawing No. 0380)

Uncoated	Nile C ₁	Ha ₂	Ha	re.	2
----------	---------------------	-----------------	----	-----	---

Knob fragment. Wd: 3.10 cm; H₁: 8.20 + x cm; Hd: 5.30 x 4.90 cm. Surface colour: 7.5YR 5/3 brown. Break: 7.5YR 5/1 grey core; 7.5YR 5/3 brown oxidation zones. Technical details: fingerprints on the knob. Surface treatment: uneven.

No. 181: lid (Fig. 40:13), Inv. No. P0032A (Drawing No. 0003)

Uncoated	Nile B ₂	W ₂	re.	2
----------	---------------------	----------------	-----	---

Body fragment; straight everted walls. Md: Wd: 1.60-1.80 cm; H₁: 4.50 + x cm. Surface colour: 2.5YR 5/6 red. Break: 5YR 4/6 yellowish red. Technical details: throwing lines inside. Surface treatment: smoothed on the wheel. Smoked inside and outside.

No. 182: lid of an oven? (Fig. 40:14), Inv. No. P0098A (Drawing No. 0020)

Uncoated	Nile E ₁	W ₁	W	ox.	2-3
----------	---------------------	----------------	---	-----	-----

Complete, fragmentary; everted direct rim. Rd: 28.20 cm; Bd: 26.40 cm; Md: ca. 29.00 cm; Wd: 2.50 cm; H₁: 3.70 cm. VI: 762. Surface colour: 2.5YR 5/4 weak red. Break: 2.5YR 4/8 dark red. Surface treatment: smoothed on the wheel.

No. 183: bakery tray (Fig. 40:14), Inv. No. P0571A (Drawing No. 0234)

Uncoated	Nile B ₂	W ₁	Ha	ox.	2
----------	---------------------	----------------	----	-----	---

Complete, fragmentary; thickened rim inside; everted direct rim. Rd: 22.00 cm 1/8; Bd: 20.00 cm 5/32; Wd: 1.40-2.20 cm; H₁: 3.30 cm. VI: 667. Surface colour: 10R 5/6 red. Break: 10R 4/4 weak red core; 10R 4/8 red oxidation zones. Surface treatment: smoothed

by hand. Eroded rim inside.

No. 184: bakery tray (Fig. 40:14), Inv. No. P0632A (Drawing No. 0380)

Uncoated	Nile B ₂	W ₁	Ha	ox.	2
----------	---------------------	----------------	----	-----	---

Complete, fragmentary; everted direct rim. Rd: 20.00 cm 3/32; Bd: 16.50 cm 1/16; H₁: 3.10 cm. VI: 645. Surface colour: 10R 6/6 light red. Break: 10R 3/2 dusky red core; 10R 4/8 red oxidation zones. Surface treatment: smoothed. Salt incrustrated; eroded inside.

No. 185: bakery tray (Fig. 40:14), Inv. No. P0631A (Drawing No. 0380)

Uncoated	Nile B ₂	W ₁	Ha	ox.	2
----------	---------------------	----------------	----	-----	---

Complete, fragmentary; everted direct rim; flat base. Rd: 18.00 cm 3/32; Bd: 16.00 cm 1/8; Wd: 1.20 cm; H₁: 4.50 cm. VI: 400. Surface colour: 2.5YR 5/6 red. Break: 10R 4/6 red. Technical details: fingerprints inside. Eroded.

No. 186: bakery tray (Fig. 40:14), Inv. No. P1003A (Drawing No. 0362)

Uncoated	Nile C ₂	W ₁	Ha	ox.	2
----------	---------------------	----------------	----	-----	---

Complete, fragmentary; everted direct rim, flat base. Rd: 20.00 cm 1/8; Bd: 18.00 cm; Md: Wd: 1.45-1.80 cm; H₁: 4.70 cm. VI: 426. Surface colour: 10R 5/6 red. Break: 2.5YR 4/8 red. Technical details: throwing lines inside, and on the rim. Surface treatment: smoothed. Eroded base.

No. 187: bakery tray (Fig. 40:14), Inv. No. P0585A (Drawing No. 0117)

Uncoated	Nile E ₂	W ₁	Ha	ox.	2
----------	---------------------	----------------	----	-----	---

Complete, fragmentary; flat base; everted direct rim. Rd: 18.00 cm 3/16; Bd: 16.00 cm 1/8; Wd: 1.10 cm; H₁: 3.80 cm. VI: 474. Surface colour: 2.5YR 5/6 red. Break: 2.5YR 5/8 red. Eroded inside and outside. Others, Rd: 23.00 cm 3/32, Bd: 26.00 cm 3/32, Rd: 28.00 cm 1/32.

No. 188: bakery tray (Fig. 40:14), Inv. No. P0633A (Drawing No. 0380)

Uncoated	Nile B ₂	W ₁	Ha	med.	2
----------	---------------------	----------------	----	------	---

Complete, fragmentary; flat base; everted direct rim, round lip. Rd: 16.00 cm 1/16; Bd: 14.00 cm 1/8; Wd: 1.00-1.50 cm; H₁: 3.00 cm. VI: 533. Surface colour: 10R 5/6 red. Break: 10R 5/6 red. Eroded.

No. 189: bakery tray (Fig. 40:14), Inv. No. P0630A (Drawing No. 0380)

Uncoated	Nile C ₂	W ₁	Ha	med.	2
----------	---------------------	----------------	----	------	---

Base fragment. Bd: 24.00 cm 3/16; Wd: 1.80 cm; H₁: 4.50 + x cm. Surface colour: 2.5YR 5/6 red. Break: 2.5YR 3/2 dusky red. Surface treatment: uneven. Salt incrustation on the base; smoked inside; very coarse.

No. 190: bakery tray, Inv. No. C-2000 [013bis]

Uncoated	Nile C ₂	W ₁	Ha
----------	---------------------	----------------	----

Fragment; eroded.

No. 191: bakery tray (Fig. 40:15), Inv. No. P0600A (Drawing No. 0282)

Uncoated	Nile B ₂	W ₁	Ha	ox.	2
----------	---------------------	----------------	----	-----	---

Base fragment. Bd: 12.00 cm 3/32; Wd: 1.30 cm; H₁: 3.00 + x cm. Surface colour: 2.5YR 4/6 red. Break: 2.5YR 3/6 dark red. Surface treatment: uneven. Eroded and salt incrustrated.

No. 192: tray (Fig. 40:15), Inv. No. C-0521 [014]

Uncoated	Nile C ₂	Ha ₁
----------	---------------------	-----------------

Fragment; D: 50.00 cm 3/16; Wd: 2.80 cm; H₁: 4.20 cm; uneven. Others, Nile C₁, D: 24.00 cm 1/16, D: 26.00 cm 3/64, D: 42.00 cm 1/16. Nile C₂, D: 20.00 cm 1/16, D: 30.00 cm 1/16, D: 34.00 cm 1/16, D: 36.00? cm 1/16, D: 38.00 cm 1/16, D: 40.00 cm 3/4, D: 48.00 cm 7/32, D: 50.00 cm 1/16, D: 52.00 cm 1/8.

No. 193: spinning bowl (Fig. 40:15), Inv. No. P7062A (before Inv. No. P3000A. Drawing No. 0220)

RS	Nile C ₁	W ₁	---	ox.	2-3
----	---------------------	----------------	-----	-----	-----

Rim sherd; everted articulated rim, exterior lip. Rd: 32.00 cm 3/32; Wd: 1.20 cm; H₁: 7.80 + x cm. Surface colour: 10R 5/4 weak red slip. Break: 10R 5/6 red. Technical details: throwing lines inside; a hole in the wall made before firing. Surface treatment: smoothed on the wheel.

No. 194: oil lamp (Fig. 40:15), Inv. No. C-0521 [146]

Uncoated	Nile B ₂	W ₂
----------	---------------------	----------------

Rim fragment; everted direct rim. Rd: 13.00 cm; Wd: 1.70 cm; H₁: 2.40 + x cm; throwing lines; smoothed on the wheel; smoked.

No. 195: "pigeon pot" (Fig. 40:15), Inv. No. P0017A (Drawing No. 0220)

RS	Nile C ₁	W ₁	W	ox.	2-3
----	---------------------	----------------	---	-----	-----

Base sherd; flat base. Md: 10.20 + x cm; Bd: 5.10 cm; Wd: 1.50 cm; H₁: 3.00 cm. Surface colour: 10R 5/4 weak red slip. Break: 10R 5/6 red. Technical details: throwing lines inside; a hole in the middle of the base. Surface treatment: smoothed on the wheel.

No. 196: "pigeon pot" (Fig. 40:15), Inv. No. C-0117 [016]

Uncoated	Nile C ₂	W ₂	W
----------	---------------------	----------------	---

Base sherd; flat base. Bd: 4.00 cm; Wd: 1.20 cm; H₁: 4.70 + x cm; throwing lines; a hole in the base; smoothed on the wheel.

Votive pottery

No. 197: votive pilgrim flask (Fig. 40:16), Inv. No. P0623A (Drawing No. 0255)

P	Nile B ₂	W ₁ + Ha ₁	---	ox.	2-3
---	---------------------	----------------------------------	-----	-----	-----

Neck, body and handle fragment. Nd: 1.30 cm; Md: 2.60-5.70 cm; Wd: 0.40 cm; H₁: 6.95 + x cm; H₃: 2.00 + x cm; Hd: 0.98 x 0.45 cm; 2 handles; single strap. Surface colour: 2.5YR 5/3 reddish brown; polished: 2.5YR 7/3 light reddish brown. Break: 7.5YR 4/1 dark grey core; 2.5YR 5/6 red oxidation zones. Technical details: made in two halves that are then joined. Surface treatment: polished. *Find No. 010.*

No.198: votive vesel? Nile B₂ body sherd, eroded.

No. 199: votive storage jar (Fig. 40:16), Inv. No. P0638A (Drawing No. 0264)

Uncoated	Nile B ₂	Ha ₁	Ha	med.	2
----------	---------------------	-----------------	----	------	---

Complete, fragmentary; rounded base; inverted direct rim. Rd: 2.60 cm; Md: 5.50 cm; Wd: 0.40-0.60 cm; H₁: 9.10 cm; H₂: 2.00 cm. VI: 60. Surface colour: 10R 6/6 light red. Break: 10R 5/8 red. Eroded outside. *Find No. 024.*

No. 200: votive pot (Fig. 40:16), Inv. No. P0013A (Drawing No. 0219)

Uncoated	Nile B ₂	W ₁	W	ox.	2
----------	---------------------	----------------	---	-----	---

Complete, fragmentary; globular shape, rounded base; direct rim (a small part of the rim is lacking). Rd: 3.40 cm 3/4; Nd: 3.35 cm; Md: 5.50 cm; Wd: 0.38 cm; H₁: 6.00 cm; H₂: 2.60 cm; H₃: 1.40 cm VI: 92. Surface colour: 5YR 5/6 yellowish red. Break: 5YR 5/8 yellowish

red. Surface treatment: smoothed on the wheel.

Egyptian marls

Fine ware

No. 201 : juglet (Fig. 40:16), Inv. No. P7019A (Drawing No. 0905)

Uncoated	Marl F f.	W ₂	---	ox.	2
----------	-----------	----------------	-----	-----	---

Neck fragment; compound-necked juglet. Nd: 3.50-4.00 cm; Wd: 0.35 cm; H₃: 3.30 + x cm. Surface colour: 7.5YR 6/3 light brown self slip. Break: 2.5YR 5/6 red. Surface treatment: polished. Eroded.

No. 202: juglet handle, Inv. No. C-0020 [009], Marl F, Hd: 1.10 x 1.00 cm.

No. 203: jug (Fig. 40:17), Inv. No. P7099A (Drawing No. 0938)

RP	Marl F f.	W ₂	---	ox.	3
----	-----------	----------------	-----	-----	---

Shoulder fragment. Md: ca. 11.00 cm; Wd: 0.45 cm; H₁: 3.30 + x cm. Surface colour: slip: 10R 4/6 red. Break: 7.5YR 5/4 brown. Surface treatment: polished. Eroded inside and outside.

Household ware

No. 204: bowl (Fig. 40:17), Inv. No. C-0521 [139]

Uncoated	Marl F	W ₂
----------	--------	----------------

Rim sherd; decorated rim; everted articulated exterior rim. Rd: 30.00 cm 1/16; Wd: 1.50 cm; H₁: 2.00 + x cm. Throwing lines inside and outside; smoothed.

No. 205: bowl (Fig. 40:17), Inv. No. C-0521 [157]

Uncoated	Marl F	W ₂
----------	--------	----------------

Rim sherd; everted articulated exterior rim, round lip. Rd: 34.00 cm 1/16; Wd: 1.50 cm; H₁: 3.50 + x cm. Throwing lines inside and outside; smoothed on the wheel.

No. 206: bowl (Fig. 40:17), Inv. No. C-0521 [050]

Uncoated	Marl F	W ₂
----------	--------	----------------

Rim sherd; everted direct rim, folded lip. Rd: 30.00 cm 1/16; Wd: 1.35 cm; H₁: 4.50 + x cm. Throwing lines inside and outside; smoothed on the wheel.

No. 207: bowl, Inv. No. C-0521 [200]

Uncoated	Marl F	W ₂
----------	--------	----------------

Body sherd; eroded.

No. 208: jug (Fig. 40:17), Inv. No. P7048A (Drawing No. 0924)

Uncoated	Marl F	W ₂ + Ha ₂	---	re.	3
----------	--------	----------------------------------	-----	-----	---

Rim, neck and handle fragment; inverted direct rim; attached vertical loop handle from the rim. Rd: 10.00 cm 1/8; Nd: 15.00 cm; H₃: 3.35 + x cm; Hd: 3.20 x 1.80 cm; 1; single strap. Surface colour: 7.5YR 6/4 light brown (self slip by overfired). Break: 7.5YR 4/2-4/3 brown. Surface treatment: smoothed.

No. 209: jar (Fig. 40:17), Inv. No. C-0521 [025]

Uncoated	Marl A ₄	W ₂
----------	---------------------	----------------

Rim sherd; everted direct rim. Rd: 12.00 cm 1/32; Wd: 0.30 cm; H₁: 1.70 + x cm. Throwing lines inside and outside; smoothed on the wheel.

No. 210: jar, Inv. No. C-0116 (2) [001], Marl A₄ + limestone, body sherds, Wd: 0.76 cm; H₁: 1.33 + x cm, smoothed on the wheel.

No. 211: amphora (Fig. 40:17), Inv. No. C-0521 [138]

Uncoated	Marl F	W ₂
----------	--------	----------------

Rim sherd; vertical direct rim. Rd: 9.00 cm 1/4; Wd: 0.80 cm; H₁: 3.40 + x cm. Throwing lines inside and outside; smoothed on the wheel. Another, Marl F s., Rd: 12.00 cm 3/32.

No. 212: amphora (Fig. 40:17), Inv. No. C-0521 [133]

Uncoated	Marl F	W ₂
----------	--------	----------------

Rim sherd; vertical direct rim, modelled lip. Rd: 10.00 cm 3/16; Wd: 0.80 cm; H₁: 3.50 + x cm. Throwing lines inside and outside; smoothed on the wheel. Another, Rd 10.00 cm 1/4.

No. 213: amphora, Inv. No. C-0396 [011]

Uncoated	Marl F	W ₂
----------	--------	----------------

Neck fragment. Wd: 0.30 cm; H₁: 2.60 + x cm; throwing lines inside and outside; smoothed on the wheel.

No. 214: amphora, Inv. No. C-0276 [002]

Uncoated	Marl F	Ha ₂
----------	--------	-----------------

Handle fragment; loop handle. Hd: 2.95 x 2.00 cm; smoothed. Others, Hd: 3.69 x 2.00; Hd: 3.70 x 2.80 cm; Hd: 2.90 x 2.00 cm.

No. 215: amphora, Inv. No. C-0379 [046]

Uncoated	Marl F	W ₂
----------	--------	----------------

Shoulder and body fragment; "torpedo" type. Md: 22.00 cm; Wd: 0.50 cm; H₁: 3.20 + x cm. Throwing lines inside and outside; smoothed.

No. 216: amphora (Fig. 40:17), Inv. No. C-0521 [153]

Uncoated	Marl F	W ₂
----------	--------	----------------

Shoulder and handle fragment; attached from shoulder to body vertical loop handle. Md: 24.00 cm; Wd: 0.80 cm; H₁: 8.00 + x cm; Hd: 2.40 x 1.50 cm. Throwing lines inside and outside; smoothed.

No. 217: amphora (Fig. 40:17), Inv. No. C-0521 [135]

Uncoated	Marl F	W ₂
----------	--------	----------------

Shoulder, body and handle fragments (reconstructed shape); "torpedo" type; attached from shoulder to body vertical loop handle. Md: 25.00 cm; Wd: 0.65 cm; H₁: 10.00 + x cm; Hd: 2.50 x 1.60 cm. Throwing lines inside and outside; smoothed.

No. 218: amphora (Fig. 40:18), Inv. No. P1278A (Drawing No. 0613)

Uncoated	Marl F s.	Ha ₂	---	ox.	3
----------	-----------	-----------------	-----	-----	---

Handle fragment. Hd: 3.40 x 1.80 cm; single strap. Surface colour: 5YR 5/4 reddish brown. Break: 5YR 4/4 reddish brown. Surface treatment: smoothed.

Body sherds: Nile B₁: 0.10 dm²; Nile B₂: 537.00 dm²; Nile C₁: 47.00 dm²; Nile C₂: 65.00 dm²; Nile E₁: 0.50 dm²; Nile E₂: 17.00 dm². Marl A₄: 1.10 dm²; Marl A₄ c.: 2.40 dm²; Marl A₄ + limestone: 1.10 dm²; Marl F: 4.00 dm²; Marl F s.: 0.20 dm²; Marl F v.s.: 4.00 dm².

b) North Sinai / Southern Palestine pottery

Fine ware

White Painted ware**No. 219: juglet (Fig. 40:18), Inv. No. P0536A (Drawing No. 0928)**

BSMO	II.TG 08	W ₂	---	ox.	2
------	----------	----------------	-----	-----	---

Body sherd. Md: 10.00 cm ; Wd: 0.30 cm; H₁: 2.00 + x cm. Surface colour: 10YR 7/4 very pale brown slip. Break: 10YR 7/3 very pale brown. Decoration: a vertically painted line, 2 mm wide, 10YR 6/2 light brownish grey. Surface treatment: polished, low lustre.

No. 220: jar or jug? (Fig. 40:18), Inv. No. P1282A (Drawing No. 0929)

WPMO	II.TG 14	---	W ₂	med.	3
------	----------	-----	----------------	------	---

Neck sherd. Nd: 11.00 cm 1/16; Wd: 0.60 cm; H₃: 2.20 + x cm. Surface colour: 2.5Y 8/3 pale yellow slip. Break: 5YR 5/3 reddish brown core; 5YR 6/6 reddish yellow oxidation zones. Technical details: throwing lines inside. Decoration: a painted band, 15 mm, 5Y 4/1 dark grey. Surface treatment: polished, low lustre. *Find No. 010.*

Bichrome ware**No. 221: jar (Fig. 40:18), Inv. No. P0016A (Drawing No. 0062)**

BPBI	II.TG 10	W ₂	---	ox.	3
------	----------	----------------	-----	-----	---

Body sherd. Md: ca. 17.20 cm; Wd: 0.43 cm; H₁: 3.15 + x cm. Surface colour: 10YR 7/4 very pale brown. Break: 2.5Y 6/3 light yellowish brown core; 10YR 6/4 light yellowish brown oxidation zones. Technical details: shallow grooves on the interior. Decoration: painted lines, 10YR 2/1 black and 2.5YR 5/8 red. Surface treatment: polished, medium lustre.

Household ware**No. 222: jug? (Fig. 40:18), Inv. No. P0843A (Drawing No. 0662)**

Uncoated	II.TG 08	Ha ₂ + W ₂	---	ox.	3
----------	----------	----------------------------------	-----	-----	---

Handle and wall fragment. Md: 7.50 cm 1/4; Wd: 0.40 cm; H₁: 4.20 + x cm; Hd: 1.20 x 1.60 cm; single strap. Surface colour: 7.5YR 7/6 reddish yellow. Break: 7.5YR 6/4 light brown. Technical details: throwing lines inside. Surface treatment: smoothed.

No. 223: amphora, II.TG 08, body sherds: 0.80 dm².**No. 224: amphora (Fig. 40:18), Inv. No. C-0521 [105]**

Uncoated	II.TG 09	W ₂
----------	----------	----------------

Rim and shoulder fragment; inverted articulated exterior rim, modelled lip. Rd: 12.00 cm 3/16; Wd: 0.80 cm; H₁: 5.00 + x cm. Throwing lines inside; smoothed on the wheel.

No. 225: amphora (Fig. 40:18), Inv. No. C-0521 [104]

Uncoated	II.TG 09	W ₂
----------	----------	----------------

Rim sherd; inverted articulated interior rim, round lip. Rd: 12.00 cm 1/4; Wd: 0.75 cm; H₁: 3.00 + x cm. Throwing lines inside; smoothed on the wheel.

No. 226: amphora, II.TG 09, body sherds: 1.10 dm².**No. 227: amphora, II.TG 10, body sherds: 10.30 dm².****No. 228: amphora, Inv. No. C-0521 [101]**

Uncoated	II.TG 14	W ₂
----------	----------	----------------

Rim sherd; vertical articulated interior rim, modelled lip. Rd: 10.00 cm 1/4; Wd: 0.75 cm; H₁: 3.20 + x cm. Throwing lines inside; smoothed on the wheel; eroded.

No. 229: amphora, Inv. No. C-0006 [006]

Uncoated	II? TG 59	Ha ₂
----------	-----------	-----------------

Handle fragment; “torpedo” type. Hd: 2.20 x 1.26 cm. Smoothed.

No. 230: amphora, Inv. No. C-0117 [008]

Uncoated	II? TG 59 c.	Ha ₂
----------	--------------	-----------------

Handle fragment; vertical loop handle. Hd: 2.50 x 1.60 cm. Smoothed.

No. 231: amphora, Inv. No. C-0117 [017]

Uncoated	II? TG 59 c.	W ₂	W
----------	--------------	----------------	---

Base fragment; flat base. Bd: 8.00 cm; Wd: 1.70 cm; H₁: 4.30 + x cm.

No. 232: amphora, II?.TG 59 c. , body sherds: 20.00 dm².

Pottery with special functions

No. 233: “mortarium” (Fig. 40:19), Inv. No. P7090A (Drawing No. 0933)

Uncoated	II? TG 47	W ₂	W	ox.	3
----------	-----------	----------------	---	-----	---

Base fragment; flat base, undulated side walls. Bd: 16.50 cm 5/32; Md: 25.00 + x cm; Wd: 1.30 cm. Surface colour: 10YR 7/3 very pale brown. Break: 10YR 7/4 very pale brown. Surface treatment: smoothed on the wheel.

c) Imported Pottery

Levantine fine ware

No. 234: “mortarium”? (Fig. 40:19), Inv. No. P1279A (Drawing No. 0620)

Uncoated	IV.?	W ₂	---	med.	3
----------	------	----------------	-----	------	---

Rim and body sherd; vertical direct rim. Rd: 18.90 cm 3/32; Wd: 0.75 cm; H₁: 4.00 + x cm. Surface colour: 5YR 6/4 light reddish brown. Break: 5YR 5/3 reddish brown core; 5YR 6/6 reddish yellow oxidation zones. Technical details: throwing lines inside. Surface treatment: smoothed on the wheel.

No. 235: juglet (Fig. 40:19), Inv. No. P0139A (Drawing No. 0159)

RP	= TD IV.21	W ₂	---	ox.	2
----	------------	----------------	-----	-----	---

Rim and neck fragment; vertical articulated exterior rim; rounded lip. Rd: 3.00 cm 1/2; Nd: 4.00 cm; Wd: 0.30 cm; H₃: 4.00 + x cm. Surface colour: 10R 6/8 light red slip. Break: 10R 5/8 red. Surface treatment: polished, low lustre.

No. 236: jug or juglet, Inv. No. P2030A (Drawing No. 0454)

RP	IV.TG 51 (= TD IV.19)	Ha ₂	---	ox.	3
----	-----------------------	-----------------	-----	-----	---

Handle fragment; loop handle; Hd: 1.60 x 1.40 cm; 1; single strap. Surface colour: 5YR 5/6 yellowish red slip. Break: 5YR 6/8 reddish yellow. Technical details: throwing lines inside. Surface treatment: polished, low lustre. Eroded.

No. 237: juglet (Fig. 40:19), Inv. No. P1052A (Drawing No. 0388)

WP	IV.TG 03	W ₂	W	ox.	3
----	----------	----------------	---	-----	---

Base and body fragment; flattened base. Bd: 3.40 cm; Wd: 0.50 cm; H₁: 2.00 + x cm. Surface colour: 7.5YR 8/2 pinkish white slip. Break: 10R 5/8 red. Surface treatment: polished, low lustre. Eroded on the interior.

No. 238: juglet (Fig. 40:19), Inv. No. P0777A (Drawing No. 0657)

RP	IV.TG 51 (= TD IV.19)	Ha ₂	---	ox.	3
----	-----------------------	-----------------	-----	-----	---

Handle fragment; loop handle. Hd: 0.60 x 1.00 cm; 1; single strap. Surface colour: 2.5YR 5/6 red slip. Break: 5YR 6/6 reddish yellow. Technical details: throwing lines inside.

Decoration: ---. Surface treatment: polished, high lustre.

White Painted II?

No. 239: juglet (Fig. 40:19), Inv. No. P1177A (Drawing No. 0700)

BPMO	IV.TG 01	W ₂	---	ox.	3
------	----------	----------------	-----	-----	---

Body sherd. Md: 12.00 cm 1/8; Wd: 0.70 cm; H₁: 4.90 + x cm. Surface colour: 10YR 8/4 very pale brown slip. Break: 2.5YR 6/8 light red. Technical details: throwing lines inside. Decoration: parallel painted lines outside, 1-3 mm wide, 7.5YR 5/3 brown. Surface treatment: polished, low lustre.

No. 240: jug (Fig. 40:19), Inv. No. P0799A (Drawing No. 0658)

RS	IV.TG 07 f.	W ₂	---	med.	3
----	-------------	----------------	-----	------	---

Neck and rim fragment; everted trimmed lip. Rd: 8.00 cm 3/16; Nd: ca 8.40 cm; Wd: 0.50 cm; H₁: 2.90 + x cm. Surface colour: 10R 3/3 dusky red slip. Break: 5YR 5/1 grey core; 7.5YR 6/4 light brown oxidation zones. Technical details: throwing lines inside. Decoration: a painted line?. Surface treatment: smoothed on the wheel. Eroded.

White Painted ware

No. 241: jar (Fig. 40:20), Inv. No. P0805A (Drawing No. 0950)

BPMO	IV.TG 11	W ₂	---	med.	3
------	----------	----------------	-----	------	---

Body sherd. Md: ca. 20.0 cm; Wd: 0.60 cm; H₁: 4.50 + x cm. Surface colour: 10YR 8/4 very pale brown slip. Break: 10YR 5/2 greyish brown core; 5YR 6/6 reddish yellow oxidation zones. Decoration: three painted lines, 6-3 mm wide, 5YR 4/1 dark grey. Surface treatment: polished, medium lustre. Observations: salt incrustated inside.

Phoenician fine ware

No. 242: juglet (Fig. 40:20), Inv. No. P0227A (Drawing No. 0201)

WP	IV.TG 35 (= IV.Phoen.01)	W ₂	---	ox.	3
----	--------------------------	----------------	-----	-----	---

Body sherd. Md: ca.11.50 cm; Wd: 0.35 cm; H₁: 3.00 + 1.00 + x cm. Surface colour: 5YR 6/8 reddish yellow slip. Break: 5YR 6/8 reddish yellow. Technical details: throwing lines inside. Surface treatment: polished, high lustre.

Red Slipped ware?

No. 243: juglet (Fig. 40:20), Inv. No. P0839A (Drawing No. 0621)

RP	IV.TG 35 = IV.Phoen.01	W ₂	---	ox.	3
----	------------------------	----------------	-----	-----	---

Neck and body fragment; globular shape. Nd: 10.00 cm 1/8; Md: 12.00 cm; Wd: 0.40 cm; H₁: 10.50 + x cm; H₂: 4.00 + x cm. Surface colour: 10R 4/6 red slip. Break: 2.5YR 6/8 light red core; 5YR 6/4 light reddish brown oxidation zones. Technical details: throwing lines inside and outside. Surface treatment: polished, medium lustre.

No. 244: jug (Fig. 40:20), Inv. No. P1268A (Drawing No. 0711)

WP	IV.TG 35 = IV.Phoen.01	W ₂	---	ox.	3
----	------------------------	----------------	-----	-----	---

Body sherd; barrel shape. Md: 9.00 + x cm; Wd: 0.50 cm; H₁: 10.00 + x cm. Surface colour: 5YR 6/6 reddish yellow slip. Break: 5YR 6/6 reddish yellow. Technical details: throwing lines inside. Surface treatment: polished, medium lustre.

No. 245: jug (Fig. 40:20), Inv. No. P0518A (Drawing No. 0231)

RP	IV.TG 38 = IV.Phoen.02	W ₂	---	ox.	2
----	------------------------	----------------	-----	-----	---

Rim sherd; everted articulated exterior rim, rounded lip. Rd: 7.00 cm 5/32; Wd: 0.45 cm; H₁: 1.50 + x cm. Surface colour: 10R 4/6 red slip. Break: 7.5YR 6/4 light yellowish red. Technical details: throwing lines inside. Decoration: remains of red decoration on the rim

inside, 7.5YR 6/4 light yellowish red. Surface treatment: polished, low lustre.

Levantine household ware

IV.TG 01

No. 246: jug (Fig. 40:21), Inv. No. P1065A (Drawing No. 0388)

Uncoated	IV.TG 01	W ₂	---	ox.	3
----------	----------	----------------	-----	-----	---

Neck fragment. Nd: 3.20 cm; Wd: 0.50 cm; H₃: 5.40 + x cm. Surface colour: 2.5YR 7/3 pale brown. Break: 10YR 7/6 very pale brown. Technical details: throwing lines inside. Surface treatment: smoothed on the wheel.

No. 247: amphora (Fig. 40:21), Inv. No. P0850A (Drawing No. 0400)

Uncoated	IV.TG 01	W ₂	---	med.	3
----------	----------	----------------	-----	------	---

Rim sherd; slightly inverted direct rim. Rd: 10.00 cm 1/36; Wd: 0.90 cm; H₁: 2.80 + x cm. Surface colour: 2.5YR 6/6 light red. Break: 10YR 7/6 yellow inside, 5YR 6/8 reddish yellow outside. Technical details: throwing lines inside. Surface treatment: smoothed on the wheel.

No. 248 : amphora (Fig. 40:21), Inv. No. C-0521 [090]

Uncoated	IV.TG 01	W ₂			
----------	----------	----------------	--	--	--

Rim sherd; "torpedo" type; inverted articulated interior and exterior rim, modelled lip. Rd: 10.00 cm 1/4; Wd: 1.00 cm; H₁: 4.60 + x cm. Throwing lines inside; smoothed on the wheel. Others, Rd: 10.00 cm 1/4, Rd: 10.00 cm 1/32, Rd: 10.00 cm 3/8, Rd: 10.00 cm 1/32, Rd: 11.00 cm 5/32, Rd: 14.00 cm 1/8.

No. 249: amphora, Inv. No. P1045A

Uncoated	IV.TG 01	W ₂	---	med.	3
----------	----------	----------------	-----	------	---

Shoulder fragment; "torpedo" type. Md: 16.00 cm 1/16; Wd: 0.80 cm; H₁: 4.80 + x cm. Surface colour: 2.5YR 6/8 light red. Break: 10YR 5/3 brown core; 2.5YR 5/8 red and 2.5YR 7/6 light red oxidation zones. Surface treatment: smoothed on the wheel.

No. 250: amphora (Fig. 40:21), Inv. No. P1070A (Drawing No. 0656)

Coated	IV.TG 01	W ₂	---	med.	3
--------	----------	----------------	-----	------	---

Shoulder fragment; "torpedo" type. Md: 18.50 cm 1/8; Wd: 0.80 cm; H₁: 2.50 + x cm. Surface colour: 2.5YR 6/6 light red slip. Break: 2.5YR 6/1 reddish grey core; 2.5YR 6/1 reddish grey and 2.5YR 7/4 light reddish brown oxidation zones. Technical details: throwing lines inside. Surface treatment: smoothed on the wheel.

No. 251: amphora, Inv. No. C-0379 [045]

Uncoated	IV.TG 01	W ₂			
----------	----------	----------------	--	--	--

Shoulder fragment; "torpedo" type. Md: 24.00 cm; Wd: 0.80 cm; H₁: 2.70 + x cm. Throwing lines inside; smoothed on the wheel.

No. 252: amphora, Inv. No. C-0521 [094]

Uncoated	IV.TG 01	Ha ₂ + W ₂			
----------	----------	----------------------------------	--	--	--

Handle and body fragment; applied body to body vertical loop handle; Wd: 0.50 cm; Hd: 2.00 x 1.50 cm; H₁: 6.80 + x cm. Throwing lines inside; smoothed.

No. 253: amphora (Fig. 40:21), Inv. No. P0094B (Drawing No. 0150)

Coated	IV.TG 01	Ha ₂	---	ox.	3
--------	----------	-----------------	-----	-----	---

A vertical handle from a basket-handle amphora. Hd: 4.60 x 3.50 cm. Surface colour: 10YR 8/3 very pale brown. Break: 5YR 7/6 reddish yellow. Technical details: rolled

handle. Surface treatment: smoothed. Observations: in the Abu Seifa exhibition room.

No. 254: amphora (Fig. 40:22), Inv. No. P0115A (Drawing No. 0079)

Uncoated	IV.TG 01	Ha ₂ + W ₂	---	ox.	2
----------	----------	----------------------------------	-----	-----	---

Handle and wall fragment; “torpedo” type; applied vertical loop handle. Md: ca. 30.00 cm; Wd: 1.12 cm; H₁: 8.80 + x cm; Hd: 2.00 x 1.20 cm; 1; single strap. Surface colour: 5YR 6/6 reddish yellow. Break: 5YR 5/6 yellowish red. Technical details: throwing lines inside. Surface treatment: smoothed.

No. 255: handle, IV.TG 01, Hd: 2.00 x 1.50 cm, Hd: 2.20 x 1.70 cm.

No. 256: amphora, IV.TG 01, body sherds: 0.30 dm².

IV.TG 03

No. 257: bowl, Inv. No. C-0030 [001]

Uncoated	IV.TG 03	W ₂			
----------	----------	----------------	--	--	--

Rim sherd. Rd: 30.00 cm 5/32; Wd: 1.00 cm; H₁: 6.50 + x cm; throwing lines inside; smoothed on the wheel; eroded.

No. 258: amphora, Inv. No. P0075A (Drawing No. 0208)

Uncoated	IV.TG 03	Ha ₂ + W ₂	---	ox.	3
----------	----------	----------------------------------	-----	-----	---

Handle and wall fragment; “torpedo” type, flat shoulder. Wd: 0.55 cm; H₁: 8.10 + x cm; Hd: 1.60 x 1.90 cm; nearly round in section; 1 [2]; 1 strap. Surface colour: 2.5YR 5/6 red. Break: 2.5YR 5/6 red. Technical details: throwing lines inside. Surface treatment: smoothed by hand.

No. 259: amphora (Fig. 40:22), Inv. No. P1069A (Drawing No. 0461)

Uncoated	IV.TG 03	W ₂	--	med.	3
----------	----------	----------------	----	------	---

Incomplete, fragmentary; shoulder fragment; “torpedo” type. Md: 26.00 cm 1/16; Wd: 0.85 cm; H₁: 5.60 + x cm. Surface colour: 2.5YR 6/8 light red. Break: 5YR 7/6 reddish yellow (inside) and 2.5YR 6/8 light red (outside). Technical details: throwing lines inside. Surface treatment: smoothed on the wheel.

No. 260: amphora (Fig. 40:22), Inv. No. P1049A (Drawing No. 0387)

Uncoated	IV.TG 03	W ₂	---	med.	3
----------	----------	----------------	-----	------	---

Shoulder fragment; “torpedo” type. Md: ca. 22.00 cm; Wd: 0.70 cm; H₁: 2.00 + x cm. Surface colour: 2.5YR 5/8 red. Break: 10YR 7/4 very pale brown inside, 2.5YR 5/8 red outside. Technical details: throwing lines inside. Surface treatment: smoothed on the wheel.

No. 261: amphora (Fig. 40:22), Inv. No. P0163A (Drawing No. 0214)

Uncoated	IV.TG 03	W ₂	---	ox.	3
----------	----------	----------------	-----	-----	---

Shoulder fragment; “torpedo” type. Md: ca. 27.50 cm; Wd: 0.75 cm; H₁: 5.25 + x cm. Surface colour: 7.5Y 8/4 pink. Break: 2.5Y 4/1 dark reddish grey; 2.5YR 5/8 red oxidation zones. Surface treatment: smoothed on the wheel.

No. 262: amphora (Fig. 40:22), Inv. No. C-0521 [100]

Uncoated	IV.TG 03	W ₂			
----------	----------	----------------	--	--	--

Shoulder fragment; “torpedo” type. Md: 24.00 cm; Wd: 0.60 cm; H₁: 4.50 + x cm. Throwing lines inside; smoothed on the wheel.

No. 263: amphora (Fig. 40:22), Inv. No. C-0380 [091]

Uncoated	IV.TG 03	W ₂
----------	----------	----------------

Shoulder fragment; “torpedo” type. Md: 26.00 cm; Wd: 0.80 cm; H₁: 5.50 + x cm. Throwing lines inside; smoothed on the wheel.

No. 264: amphora, Inv. No. C-0006 [005]

Uncoated	IV.TG 03	Ha ₂ + W ₂
----------	----------	----------------------------------

Handle and shoulder fragment; “torpedo” type; attached vertical from shoulder to body loop handle. Wd: 0.80 cm; Hd: 2.56 x 1.40 cm; H₁: 8.74 + x cm. Throwing lines inside; smoothed.

No. 265: amphora (Fig. 40:22), Inv. No. P0162A (Drawing No. 0226)

Uncoated	IV.TG 03	W ₂	W	ox.	3
----------	----------	----------------	---	-----	---

Base and body fragment; base 1/4 preserved (the central part is lacking); [rounded?] base. Md: 10.00 + xcm; Wd: 0.50 cm; H₁: 5.50 + x cm. Surface colour: 5YR 6/6 reddish yellow. Break: 5YR 5/6 yellowish red outside; 5YR 6/1 grey inside. Technical details: made in parts; throwing lines inside; scraping marks inside. Surface treatment: smoothed.

No. 266: amphora, IV.TG 03, body sherds: 30.00 dm².

IV.TG 05

No. 267: amphora (Fig. 40:22), Inv. No. C-0521 [102]

Uncoated	IV.TG 05	W ₂
----------	----------	----------------

Rim sherd; inverted articulated interior and exterior rim, modelled lip. Rd: 13.50 cm 1/2; Wd: 0.50 cm; H₁: 2.50 + x cm. Throwing lines inside; smoothed on the wheel.

No. 268: amphora (Fig. 40:22), Inv. No. C-0521 [099]

Uncoated	IV.TG 05	Ha ₂ + W ₂
----------	----------	----------------------------------

Handle and body fragment; “torpedo” type; attached from shoulder to body vertical loop handle. Md: 18.00 cm; Wd: 0.65 cm; Hd: 2.50 x 1.70 cm; H₁: 5.50 + x cm. Throwing lines inside; smoothed.

No. 269: amphora, IV.TG 05, body sherds: 1.20 dm².

IV.TG 06

No. 270: amphora, Inv. No. C-0380 [110]

Uncoated	IV.TG 06	Ha ₂ + W ₂
----------	----------	----------------------------------

Handle and body fragment; “torpedo” type; vertical loop handle. Hd: 2.00 x 1.95 cm; H₁: 6.50 + x cm. Throwing lines inside; smoothed.

No. 271: amphora, Inv. No. C-0380 [0110]

Uncoated	IV.TG 06	Ha ₂
----------	----------	-----------------

Handle fragment; Hd: 2.00 x 1.95 cm; single strap; smoothed. Another, Hd: 2.00 x 1.20 cm. Another, Hd: 2.00 x 1.20 cm.

No. 272: amphora, IV.TG 06, body sherds: 0.40 dm².

IV.TG 07

No. 273: amphora, Inv. No. C-0521 [123]

Uncoated	IV.TG 07	W ₂
----------	----------	----------------

Rim sherd; inverted articulated interior and exterior rim, modelled folded lip. Rd: 10.00 cm 7/32; Wd: 0.60 cm; H₁: 3.50 + x cm. Throwing lines inside; smoothed on the wheel.

No. 274: amphora (Fig. 40:22), Inv. No. C-0521 [122]Uncoated | IV.TG 07 | W₂

Rim sherd; inverted direct rim. Rd: 12.00 cm 1/4; Wd: 1.00 cm; H₁: 2.50 + x cm. Throwing lines inside; smoothed on the wheel.

No. 275: amphora (Fig. 40:22), Inv. No. C-0521 [124]Uncoated | IV.TG 07 | W₂

Shoulder fragment; "torpedo" type. Md: 22.00 cm; Wd: 0.55 cm; H₁: 3.80 + x cm. Throwing lines inside; smoothed on the wheel.

No. 276: amphora (Fig. 40:23), Inv. No. C-0521 [125]Uncoated | IV.TG 07 | W₂ + Ha₂

Shoulder and handle fragment; "torpedo" type; attached from shoulder to body vertical loop handle. Md: 22.00 cm; Wd: 0.70 cm; Hd: 2.40 x 1.70 cm; H₁: 8.00 + x cm.

No. 277: amphora (Fig. 40:23), Inv. No. C-0379 (2) [001]Uncoated | IV.TG 07 | W₂ + Ha₂

Shoulder and handle fragment; "torpedo" type; attached vertical from upper body to shoulder loop handle. Md: ca. 26.00 cm on the shoulder; Wd: 0.70 cm; Hd: 2.15 x 1.50 cm, H₁: 3.00 + x cm. Throwing lines inside; smoothed.

No. 278: amphora (Fig. 40:23), Inv. No. P1289A (Drawing No. 0709)Uncoated | IV.TG 07 | Ha₂ + W₂ | -- | re. | 3

Handle and body fragment; "torpedo" type; applied handle. Md: ca. 26.00 cm on shoulder; Wd: 0.70 cm; H₁: 6.00 + x cm; Hd: 2.00 x 1.40 cm; single strap. Surface colour: 2.5Y 7/3 pale yellow. Break: 2.5Y 6/1 grey. Technical details: throwing lines inside; fingerprints on the handle. Surface treatment: smoothed.

No. 279: amphora, Inv. No. C-0135 [012]Uncoated | IV.TG 07 | Ha₂

Handle fragment; attached from shoulder to body vertical loop handle. Hd: 2.00 x 1.40 cm; H₁: 6.50 + x cm; smoothed.

No. 280: amphora, IV.TG 07, body sherds: 26.30 dm².

IV.TG 11**No. 281: jar?, Inv. No. C-0379 [003]**Uncoated | IV.TG 17 | W₂

Rim sherd; everted. Rd: 8.00 cm 5/32; Wd: 0.60 cm; H₁: 3.20 + x cm; throwing lines inside; smoothed on the wheel.

No. 282: amphora (Fig. 40:23), Inv. No. P7037A (Drawing No. 0911)Coated | IV.TG 11 | W₂ | --- | ox. | 3

Rim and body fragment; "torpedo" type; vertical direct rim, trimmed lip. Rd: 11.50 cm; Md: 23.50 cm; Wd: 0.70 cm; H₁: 2.50 + x + 13.50 + x cm. Surface colour: 10YR 7/3 very pale brown slip. Break: 7.5YR 5/4 light brown. Technical details: ridges outside and inside. Surface treatment: smoothed on the wheel. Eroded inside. Find No. 036bis.

No. 283: amphora, Inv. No. C-0379 [028]Uncoated | IV.TG 11 | W₂

Rim sherd; inverted direct rim. Rd: 8.00 cm 3/32; Wd: 0.60 cm; H₁: 2.70 + x cm.

Throwing lines inside; smoothed on the wheel.

No. 284: amphora (Fig. 40:23), Inv. No. C-0521 [120]

Uncoated	IV.TG 11	W ₂
----------	----------	----------------

Rim sherd; vertical modelled rim. Rd: 10.00 cm 3/32; Wd: 0.60 cm; H₁: 3.50 + x cm. Throwing lines inside; smoothed on the wheel.

No. 285: amphora, Inv. No. C-0014 [007]

Uncoated	IV.TG 11	W ₂
----------	----------	----------------

Rim sherd; everted modelled rim, trimmed and modelled lip. Rd: 10.00 cm 1/8; Wd: 0.69 cm; H₁: 2.00 + x cm. Throwing lines inside; smoothed on the wheel, eroded.

No. 286: amphora (Fig. 40:23), Inv. No. P0071A (Drawing No. 0655)

Uncoated	IV.TG 11 f.	Ha ₂ + W ₂	---	med.	3
----------	-------------	----------------------------------	-----	------	---

Handle and shoulder fragment; "torpedo" type. Md: ca. 22.00 cm; Wd: 0.70 cm; H₁: 2.70 + x cm; Hd: 2.20 x 1.40 cm; 2; 1 strap. Surface colour: 2.5YR 8/3 pale yellow. Break: 7.5 5/1 grey core; 7.5YR 8/6 reddish yellow oxidation zones. Surface treatment: smoothed.

No. 287: amphora (Fig. 40:23), Inv. No. P1288A (Drawing No. 0710)

Uncoated	IV.TG 11	Ha ₂ + W ₂	---	ox.	3
----------	----------	----------------------------------	-----	-----	---

Handle and shoulder fragment; "torpedo" type. Md: 22.00 cm 3/32; Wd: 0.50 cm; H₁: 7.60 + x cm; Hd: 2.20 x 1.60 cm; 1 [2]; 1 strap. Surface colour: 10R 7/6 light red. Break: 10R 5/2 weak red core; 10R 7/6 light red oxidation zones. Technical details: throwing lines inside; fingerprints on the handle. Surface treatment: smoothed.

No. 288: amphora (Fig. 40:24), Inv. No. P0095B (Drawing No. 0161)

Uncoated	IV.TG 11	W ₁ + Ha ₂	---	ox.	3
----------	----------	----------------------------------	-----	-----	---

Shoulder, handle and body fragment; "torpedo" type. Md: ca. 24.00 cm; Wd: 0.80 cm; H₁: 11.00 + x cm; Hd: 2.40 x 1.40 cm; 1 [2]; single strap. Surface colour: 10YR 8/3 very pale brown. Break: 10YR 5/1 grey. Technical details: applied handle; throwing lines inside. Surface treatment: smoothed. Observations: in the Abu Seifa exhibition room.

No. 289: amphora (Fig. 40:24), Inv. No. C-0521 [119]

Uncoated	IV.TG 11	W ₂ + Ha ₂
----------	----------	----------------------------------

Shoulder and handle fragment; "torpedo" type; attached from shoulder to body vertical loop handle. Md: 20.00 cm; Wd: 0.80 cm; Hd: 2.60 x 1.60 cm; H₁: 7.50 + x cm. Throwing lines inside; smoothed.

No. 290: amphora (Fig. 40:24), Inv. No. C-0380 (2) [001]

Uncoated	IV.TG 11	W ₂ + Ha ₂
----------	----------	----------------------------------

Shoulder and handle fragment; loop handle. Md: 17.00 cm; Hd: 2.70 x 1.90 cm; H₁: 6.20 + x cm. Throwing lines inside; smoothed.

No. 291: amphora (Fig. 40:24), Inv. No. C-0135 [024]

Uncoated	IV.TG 11	W ₂
----------	----------	----------------

Shoulder fragment; "torpedo" type. Md: ca. 23.00 cm; Wd: 0.60 cm; throwing lines inside; smoothed on the wheel.

No. 292: amphora (Fig. 40:24), Inv. No. C-0521 [103]

Uncoated	IV.TG 11	Ha ₂ + W ₂
----------	----------	----------------------------------

Handle fragment; "torpedo" type; attached from shoulder to body vertical loop handle. Md:

26.00 cm; Wd: 0.65 cm; H_1 : 7.50 + x cm; Hd: 2.50 x 1.70 cm. Throwing lines inside; smoothed.

No. 293: amphora, Inv. No. C-0380 [114]

Uncoated	IV.TG 11	Ha ₂
----------	----------	-----------------

Handle fragment; vertical loop handle. Hd: 2.90 x 1.70 cm. Smoothed. Others, Hd: 1.50 x 1.20 cm; Hd: 2.40 x 1.80 cm.

No. 294: amphora, Inv. No. C-0380 [114]

Uncoated	IV.TG 11	Ha ₂
----------	----------	-----------------

Handle fragment; vertical loop handle; Hd: 2.90 x 1.70 cm; single strap; smoothed.

No. 295: amphora, IV.TG 11, body sherds: 20.20 dm².

IV.TG 17

No. 296: amphora (Fig. 40:24), Inv. No. C-0006 [019]

Uncoated	IV.TG 17	W ₂
----------	----------	----------------

Rim sherd; vertical articulated modelled rim, trimmed lip. Rd: 9.00 cm 5/32; Wd: 0.50 cm; H_1 : 2.95 + x cm. Throwing lines inside; smoothed on the wheel.

No. 297: amphora, Inv. No. C-0379 [003]

Uncoated	IV.TG 17	W ₂
----------	----------	----------------

Rim sherd; everted articulated exterior rim, round lip. Rd: 8.00 cm 5/32; Wd: 0.60 cm; H_1 : 3.20 + x cm. Throwing lines inside; smoothed on the wheel.

No. 298: amphora, IV.TG 17, body sherds: 0.20 dm².

IV.TG 18

No. 299: amphora, IV.TG 18, body sherds: 0.80 dm².

IV.TG 19

No. 300: amphora, IV.TG 19, body sherds: 1.10 dm².

No. 301: amphora, Inv. No. C-0039 [008]

Uncoated	IV.TG 19	W ₂
----------	----------	----------------

Shoulder fragment; "torpedo" type; Wd: 0.40 cm; H_1 : 3.16 + x cm; throwing lines inside; smoothed on the wheel.

IV.TG 21

No. 302: amphora, IV.TG 21, body sherds: 0.40 dm².

IV.TG 23

No. 303: amphora (Fig. 40:24), Inv. No. P0381A (Drawing No. 0201)

Coated	IV.TG 23	W ₂	---	ox.	3
--------	----------	----------------	-----	-----	---

Rim sherd; everted direct rim. Rd: 10.00 cm 1/4; Wd: 0.70 cm; H_1 : 3.16 + x cm. Surface colour: 5YR 6/6 reddish yellow slip. Break: 10YR 6/4 light pale brown. Surface treatment: smoothed on the wheel.

No. 304: amphora (Fig. 40:25), Inv. No. P1048A (Drawing No. 0464)

Uncoated	IV.TG 23	W ₂	---	med.	4
----------	----------	----------------	-----	------	---

Shoulder fragment; "torpedo" type. Md: 26.00 cm 3/32; Wd: 0.50 cm; H_1 : 6.00 + x cm.

Surface colour: 5YR 7/6 reddish yellow. Break: 2.5YR 6/1 reddish grey core; 5YR 7/6 reddish yellow oxidation zones. Technical details: throwing lines inside and outside. Surface treatment: smoothed on the wheel.

No. 305: amphora (Fig. 40:25), Inv. No. C-0521 [097]

Uncoated	IV.TG 23	Ha ₂ + W ₂
----------	----------	----------------------------------

Handle and shoulder fragment; attached from shoulder to body vertical loop handle. Md: 23.00 cm; Wd: 0.50 cm; Hd: 2.70 x 1.60 cm; H₁: 10.00 + x cm. Throwing lines inside; smoothed.

No. 306: amphora, Inv. No. C-0521 [096]

Uncoated	IV.TG 23	Ha ₂ + W ₂
----------	----------	----------------------------------

Handle and shoulder fragment; “torpedo” type; attached from shoulder to body vertical loop handle. Wd: 0.50 cm; Hd: 2.30 x 1.60 cm; H₁: 3.20 + x cm. Throwing lines inside; smoothed.

No. 307: amphora, Inv. No. C-0380 [104]

Uncoated	IV.TG 23	Ha ₂ + W ₂
----------	----------	----------------------------------

Handle and body fragment; vertical loop handle. Hd: 2.50 x 1.60 cm; H₁: 7.30 + x cm. Throwing lines inside; smoothed. Another, Hd: 2.00 x 1.35 cm.

No. 308: amphora, Inv. No. C-0135 [019]

Uncoated	IV.TG 23	W ₂	W
----------	----------	----------------	---

Base and wall fragment; round base. Wd: 1.10 cm; H₁: 18.80 + x cm. Throwing lines inside; smoothed on the wheel.

No. 309: amphora, IV.TG 23, body sherds: 22.30 dm².

IV.TG 24

No. 310: amphora (Fig. 40:25), Inv. No. C-0135 [004]

Uncoated	IV.TG 24	W ₂
----------	----------	----------------

Rim sherd; vertical direct rim, modelled lip. Rd: 9.00 cm 3/32; Wd: 0.60 cm; H₁: 3.60 + x cm. Throwing lines inside; smoothed on the wheel.

No. 311: amphora (Fig. 40:25), Inv. No. P0353A (Drawing No. 0188)

Uncoated	IV.TG 24	Ha ₂ + W ₂	---	ox.	3
----------	----------	----------------------------------	-----	-----	---

Handle and body fragment; “torpedo” type. Md: ca. 30.00 cm; Wd: 0.70 cm; H₁: 8.10 + x cm; Hd: 2.10 x 2.60 cm; 1 [2]; 1 strap. Surface colour: 10YR 8/4 very pale brown. Break: 7.5YR 7/4 pink. Technical details: handle attached from the shoulder to the body; throwing lines inside. Surface treatment: smoothed.

No. 312: amphora (Fig. 40:25), Inv. No. P1295A (Drawing No. 0708)

Uncoated	IV.TG 24	W ₂	---	med.	3
----------	----------	----------------	-----	------	---

Shoulder fragment and swelling of handle; “torpedo” type; applied handle. Md: ca. 18.00 cm on shoulder; Wd: 0.60 cm; H₁: 5.10 + x cm. Surface colour: 7.5YR 8/4 pink. Break: 7.5YR 6/6 reddish yellow inside; 5YR 7/6 reddish yellow outside. Surface treatment: smoothed.

No. 313: amphora, handle, IV.TG 24, Hd: 2.60 x 1.30 cm, Hd: 2.10 x 1.50 cm.

No. 314: amphora, Inv. No. C-0379 [049]

Uncoated	IV.TG 24	W ₂	W
----------	----------	----------------	---

Base fragment; round base. Wd: 0.60-0.80 cm; H₁: 3.00 + x cm. Throwing lines inside; smoothed on the wheel.

No. 315: amphora, IV.TG 24, body sherds: 12.30 dm².

IV.TG 25

No. 316: amphora, IV.TG 25, body sherds: 0.40 dm².

IV.TG 27

No. 317: amphora (Fig. 40:25), Inv. No. C-0055 [007]

Uncoated	IV.TG 27	W ₂
----------	----------	----------------

Rim sherd; vertical direct rim. Rd: 16.00 cm 1/16; H₁: 2.50 + x cm; throwing lines inside; smoothed on the wheel.

IV.TG 29

No. 318: amphora (Fig. 40:25), Inv. No. C-0039 [002]

Uncoated	IV.TG 29	W ₂
----------	----------	----------------

Rim sherd; inverted direct rim, slightly flaring outside. Rd: 8.00 cm 1/8; Wd: 0.55 cm; H₁: 3.00 + x cm. Throwing lines inside; smoothed on the wheel.

No. 319: amphora (Fig. 40:25), Inv. No. C-0521 [106]

Uncoated	IV.TG 29	W ₂
----------	----------	----------------

Rim sherds, and shoulder and body fragment; “torpedo” type; straight walls; vertical articulated interior rim, flattened lip; Rd: 10.00 cm 3/4; Md: 26.00 cm; Wd: 0.60-0.80 cm; H₁: 4.20 + 10.00 + x cm. Throwing lines inside; smoothed on the wheel.

No. 320: amphora, Inv. No. C-0521 [107]

Uncoated	IV.TG 29	Ha ₂ + W ₂
----------	----------	----------------------------------

Handle and body fragment; attached from shoulder to body vertical loop handle. Wd: 0.60 cm; Hd: 3.00 x 2.00 cm; H₁: 10.00 + x cm. Throwing lines inside; smoothed.

No. 321: amphora, handle, IV.TG 29, Hd: 2.60 x 1.20 cm.

No. 322: amphora, IV.TG 29, body sherds: 3.10 dm².

IV. TG 31

No. 323: amphora, Inv. No. C-0003 [017]

Uncoated	IV.TG 31	Ha ₂
----------	----------	-----------------

Handle fragment; loop handle. Hd: 2.30 x 1.17 cm. Smoothed.

No. 324: amphora, IV.TG 31, body sherds: 0.50 dm².

IV.TG 32

No. 325: amphora (Fig. 40:25), Inv. No. C-0521 [126]

Uncoated	IV.TG 32	W ₂
----------	----------	----------------

Rim sherd; inverted articulated interior and exterior rim, modelled lip. Rd: 10.00 cm 1/4; Wd: 0.50 cm; H₁: 2.30 + x cm. Throwing lines inside; smoothed on the wheel.

No. 326: amphora (Fig. 40:25), Inv. No. C-0097 (2) [002]

Uncoated	IV.TG 32	W ₂
----------	----------	----------------

Rim sherd; vertical direct rim. Rd: 10.00 cm 1/8; Wd: 0.60 cm; H₁: 3.60 + x cm. Throwing

lines inside; smoothed on the wheel.

No. 327: amphora, IV.TG 32, body sherds: 1.30 dm².

IV.TG 36

No. 328: amphora, IV.TG 36, body sherds: 0.50 dm².

IV.TG 50

No. 329: amphora (Fig. 40:26), Inv. No. P0174A (Drawing No. 0236)

Uncoated	IV.TG 50	W ₂	---	ox.	3
----------	----------	----------------	-----	-----	---

Shoulder fragment; “torpedo” type. Md: ca. 22.00 cm on the shoulder; Wd: 0.65 cm; H₁: 0.60 + x cm. Surface colour: 7.5YR 6/4 light brown. Break: 7.5YR 6/1 grey core; 7.5YR 6/4 light brown oxidation zones. Technical details: throwing lines inside. Surface treatment: smoothed on the wheel.

No. 330: amphora (Fig. 40:26), Inv. No. P0884A (before Inv. No. P0133A. Drawing No. 0236)

Uncoated	IV.TG 50	W ₂	---	ox.	3
----------	----------	----------------	-----	-----	---

Shoulder and body fragment; “torpedo” type. Md: ca. 22.00-24.00 cm; Wd: 1.00 cm; H₁: 2.47 + x cm. Surface colour: 10YR 7/3 very pale brown. Break: 10YR 7/3 very pale brown. Surface treatment: smoothed on the wheel.

No. 331: amphora (Fig. 40:26), Inv. No. P0089A (Drawing No. 0208)

Uncoated	IV.TG 50	W ₂	---	ox.	3
----------	----------	----------------	-----	-----	---

Shoulder fragment; “torpedo” type. Md: ca. 27.50 cm; Wd: 0.90 cm; H₁: 4.50 + x cm. Surface colour: 10R 7/3 very pale brown. Break: 10YR 6/1 grey core; 10YR 8/3 very pale brown oxidation zones. Surface treatment: smoothed on the wheel.

No. 332: amphora, IV.TG 50, body sherds: 3.45 dm².

IV.TG 51

No. 333: amphora (Fig. 40:26), Inv. No. P1294A (Drawing No. 0705)

Uncoated	IV.TG 51 (= TD IV.19)	W ₂	---	ox.	3
----------	-----------------------	----------------	-----	-----	---

Rim sherd; vertical direct rim. Rd: 10.00 cm 5/32; Wd: 0.80 cm; H₁: 2.60 + x cm. Surface colour: 2.5YR 7/6 light red. Break: 2.5YR 7/4 light reddish brown. Surface treatment: smoothed on the wheel.

No. 334: amphora (Fig. 40:26), Inv. No. C-0521 [116]

Uncoated	IV.TG 51 (= TD IV.19)	W ₂			
----------	-----------------------	----------------	--	--	--

Rim sherd; inverted direct rim. Rd: 11.00 cm 1/4; Wd: 0.70 cm; H₁: 3.50 + x cm. Throwing lines inside; smoothed on the wheel.

No. 335: amphora (Fig. 40:26), Inv. No. C-0521 [114]

Uncoated	IV.TG 51 (= TD IV.19)	W ₂			
----------	-----------------------	----------------	--	--	--

Rim sherd; vertical compound rim, modelled lip. Rd: 10.00 cm 3/16; Wd: 0.70 cm; H₁: 3.20 + x cm. Another, Rd: 10.00 cm 3/32.

No. 336: amphora, Inv. No. P7045A (Drawing No. 0922)

Coated	IV.TG 51 (= TD IV.19)	W ₂	W	ox.	3
--------	-----------------------	----------------	---	-----	---

Shoulder, base and body fragments; “torpedo” type. Md: 29.00 cm; Wd: 0.70-0.90 cm; H₁: 46.00 + x cm; H₂: 3.80 + x cm. Surface colour: 5YR 6/6 reddish yellow slip. Break: 7.5YR

6/4 light brown. Technical details: a groove on the shoulder. Eroded surface.

No. 337: amphora (Fig. 40:26), Inv. No. P1146A (Drawing No. 0707)

Uncoated	IV.TG 51 (= TD IV.19)	W ₂	---	med.	3
----------	-----------------------	----------------	-----	------	---

Body fragment. Md: ca. 15.00 cm; Wd: 0.70 cm; H₁: 4.40 + x cm. Surface colour: 2.5YR 7/8 light red. Break: 5YR 7/1 light reddish grey inside; 2.5YR 7/8 light red outside. Surface treatment: smoothed on the wheel.

No. 338: amphora, Inv. No. C-0521 [112bis]

Uncoated	IV.TG 51 (= TD IV.19)	W ₂
----------	-----------------------	----------------

Body sherd; eroded.

No. 339: amphora (Fig. 40:27), Inv. No. C-0521 [112]

Uncoated	IV.TG 51 (= TD IV.19)	W ₂
----------	-----------------------	----------------

Shoulder fragment; "torpedo" type. Md: 26.00 cm; Wd: 0.60 cm; H₁: 7.40 + x cm. Throwing lines inside; smoothed on the wheel.

No. 340: amphora (Fig. 40:27), Inv. No. C-0521 [113]

Uncoated	IV. TG 51 (= TD IV.19)	W ₂
----------	------------------------	----------------

Shoulder fragment; "torpedo" type. Md: 21.00 cm; Wd: 0.65 cm; H₁: 3.00 + x cm. Throwing lines inside; smoothed on the wheel.

No. 341: amphora (Fig. 40:27), Inv. No. C-0521 [165]

Uncoated	IV.TG 51 (= TD IV.19)	W ₂
----------	-----------------------	----------------

Shoulder fragment; "torpedo" type. Md: 24.00 cm; Wd: 0.70 cm; H₁: 11.80 + x cm. Throwing lines inside; smoothed on the wheel.

No. 342: amphora, Inv. No. C-0521 [118]

Uncoated	IV.TG 51 (= TD IV.19)	W ₂
----------	-----------------------	----------------

Shoulder fragment; "torpedo" type; pinched shoulder. Wd: 0.80 cm; H₁: 3.00 + x cm. Throwing lines inside; smoothed on the wheel.

No. 343: amphora (Fig. 40:27), Inv. No. C-0521 [111]

Uncoated	IV.TG 51 (= TD IV.19)	W ₂ + Ha ₂
----------	-----------------------	----------------------------------

Shoulder and handle fragment; "torpedo" type; attached from shoulder to body vertical loop handle. Md: 26.00 cm; Wd: 0.65 cm; Hd: 2.30 x 1.70 cm; H₁: 9.00 + x cm. Throwing lines inside; smoothed. Others, Md: 26.00 cm; Wd: 0.90 cm; Hd: 2.40 x 1.70 cm; Md: 26.00 cm; Wd: 0.90 cm; H₁: 8.30 + x cm; Hd: 2.40 x 1.70 cm.

No. 344: amphora, Inv. No. C-0003 [019]

Uncoated	IV.TG 51 (=TD IV.19)	Ha ₂
----------	----------------------	-----------------

Handle fragment; loop handle. Hd: 2.15 x 1.30 cm. Smoothed by hand. Another, Hd: 2.20 x 1.50 cm.

No. 345: amphora, IV.TG 51 (= TD IV.19), body sherds: 22.00 dm².

IV.TG 52

No. 346: amphora (Fig. 40:27), Inv. No. P0883A (before Inv. No. P0097A. Drawing No. 0235)

Uncoated	IV.TG 52 (= TD IV.19 c.)	W ₂	---	ox.	2-3
----------	--------------------------	----------------	-----	-----	-----

Shoulder fragment; "torpedo" type. Md: ca. 24.00 cm on the shoulder; Wd: 1.00 cm; H₁:

1.38 + x cm. Surface colour: 5YR 6/6 reddish yellow. Break: 5YR 5/6 yellowish red. Technical details: throwing lines inside. Surface treatment: smoothed.

No. 347: amphora (Fig. 40:27), Inv. No. P0099A (Drawing No. 0214)

Coated	IV.TG 52 (=TD IV.19 c.)	W ₂	---	ox.	3
--------	-------------------------	----------------	-----	-----	---

Shoulder fragment; "torpedo" type. Md: ca. 25.00 cm; Wd: 0.75 cm; H₁: 6.00 + x cm. Surface colour: 10YR 8/3 very pale brown slip. Break: 7.5YR 6/4 light brown core; 5YR 6/6 reddish yellow oxidation zones (thin). Surface treatment: smoothed on the wheel.

IV.TG 53

No. 348: bowl (Fig. 40:27), Inv. No. C-0028 [001]

Uncoated	IV.TG 53 (= TD IV.09)	W ₂
----------	-----------------------	----------------

Rim sherd; everted. Rd: 42.00 cm 3/32; Wd: 1.20 cm; H₁: 5.50 + x cm; throwing lines; smoothed on the wheel.

No. 349: amphora (Fig. 40:27), Inv. No. C-0117 [003]

Uncoated	IV.TG 53 (= TD IV.09)	W ₂
----------	-----------------------	----------------

Rim sherd; inverted articulated interior and exterior rim, modelled lip. Rd: 10.00 cm 3/16; Wd: 0.50 cm; H₁: 3.60 + x cm. Throwing lines inside; smoothed on the wheel.

No. 350: amphora (Fig. 40:27), Inv. No. C-0521 [089]

Uncoated	IV.TG 53 (= TD IV.09)	W ₂
----------	-----------------------	----------------

Shoulder fragment; "torpedo" type. Md: 23.00 cm; Wd: 0.80 cm; H₁: 4.50 + x cm. Throwing lines inside; smoothed on the wheel.

No. 351: handle, IV.TG 53 (= TD IV.9), Hd: 3.50 x 1.70 cm.

No. 352: amphora (Fig. 40:27), Inv. No. P0078A (Drawing No. 0227)

Uncoated	IV.TG 53 (= TD IV.09)	W ₂	W	ox.	3
----------	-----------------------	----------------	---	-----	---

Base and body fragment; rounded base. Md: 14.00 + x cm; Wd: 2.40 cm; H₁: 5.50 + x cm. Surface colour: 10YR 7/3 very pale brown. Break: 7.5YR 6/6 reddish yellow inside; 10YR 7/3 very pale brown outside. Surface treatment: smoothed. Observations: eroded inside.

No. 353: amphora, IV.TG 53 (= TD IV.09), body sherds: 12.10 dm².

IV.TG 57

No. 354: amphora (Fig. 40:27), Inv. No. C-0378 [004]

Uncoated	IV.TG 57 (= TD IV.12)	W ₂
----------	-----------------------	----------------

Rim sherd; inverted articulated exterior rim, modelled lip. Rd: 10.00 cm 5/32; Wd: 0.65 cm; H₁: 3.50 + x cm. Throwing lines inside; smoothed on the wheel.

No. 355: amphora, Inv. No. C-0380 [102]

Uncoated	IV.TG 57 (= TD IV.12)	W ₂	W
----------	-----------------------	----------------	---

Base fragment; round base. Wd: 0.60 cm; H₁: 2.70 + x cm. Throwing lines inside; smoothed on the wheel.

No. 356: amphora, IV.TG 57 (= TD IV.12), body sherds: 0.20 dm².

IV.TG 61

No. 357: amphora, Inv. No. C-0379 [048]

Uncoated	IV.TG 61	W ₂
----------	----------	----------------

Rim sherd; inverted articulated exterior rim, round lip. Rd: 10.00 cm 3/16; Wd: 0.60 cm; H₁: 3.10 + x cm. Throwing lines inside; smoothed on the wheel.

TD IV.02

No. 358: amphora, Inv. No. C-0001 [013]

Uncoated	= TD IV.02	Ha ₂
----------	------------	-----------------

Handle fragment; loop handle. Hd: 2.65 x 1.30 cm. Smoothed. Others, Hd: 2.13 x 1.13 cm; Hd: 2.13 x 1.13 cm.

No. 359: amphora, = TD IV.02, body sherds: 0.70 dm².

TD IV.08

No. 360: amphora, = TD IV.08, body sherds: 0.40 dm².

Phoenician household ware

No. 361: amphora, IV.TG 22 = IV.Phoen?04, body sherds: 3.70 dm².

No. 362: amphora (Fig. 40:28), Inv. No. C-0015 [009]

Uncoated	IV.TG 22 = IV.Phoen?04	W ₂
----------	------------------------	----------------

Rim sherd; inverted articulated interior and exterior rim, modelled lip. Rd: 10.00 cm 5/32; Wd: 0.50 cm; H₁: 2.38 + x cm. Throwing lines inside; smoothed on the wheel.

No. 363: amphora, IV.TG 35 = IV.Phoen.01, body sherds: 4.50 dm².

No. 364: amphora (Fig. 40:28), Inv. No. C-0521 [080]

Uncoated	IV.TG 35 = IV.Phoen.01	W ₂
----------	------------------------	----------------

Rim and shoulder fragment; vertical direct rim. Rd: 10.00 cm 1/64; Wd: 0.70 cm; H₁: 6.20 + x cm. Throwing lines inside; smoothed on the wheel.

No. 365: amphora (Fig. 40:28), Inv. No. C-0003 [010]

Uncoated	IV.TG 37 = IV.Phoen?03	W ₂
----------	------------------------	----------------

Rim sherd; vertical articulated symmetrical rim, round lip. Rd: 10.00 cm 5/32; Wd: 0.60 cm; H₁: 3.17 + x cm. Throwing lines inside; smoothed on the wheel.

No. 366: amphora, Inv. No. C-0380 [109]

Uncoated	IV.TG 37 = IV.Phoen?03	Ha ₂ + W ₂
----------	------------------------	----------------------------------

Handle and body fragment; "torpedo" type; vertical loop handle. Hd: 2.00 x 1.10 cm; H₁: 6.50 + x cm. Throwing lines inside; smoothed on the wheel.

No. 367: amphora, IV.TG 37 = IV.Phoen?03, body sherds: 6.70 dm².

No. 368: amphora, IV.TG 38 = IV.Phoen.02, body sherds: 0.10 dm².

Levantine votive or model pottery

No. 369: votive amphora (Fig. 40:28), Inv. No. P7020A (Drawing No. 0905)

Coated	IV.TG 19	W ₂	W	ox.	3
--------	----------	----------------	---	-----	---

Base 1/1 and body 1/4 fragment; rounded base. Md: 6.00 + x cm; Wd: 0.45 cm; H₁: 5.50 + x cm. Surface colour: 5YR 6/4 light reddish brown; 5/4 reddish brown slip. Break: 2.5YR 5/8 red outside, 2.5YR 5/1 reddish grey inside. Technical details: throwing lines inside. Surface treatment: smoothed on the wheel.

No. 370: votive amphora (Fig. 40:28), Inv. No. P0525A (Drawing No. 0223)

Uncoated	IV.TG 11	W ₂	W	ox.	3
----------	----------	----------------	---	-----	---

Base and wall fragment; round base. Md: 4.00 + x cm; Wd: 0.30 cm; H₁: 4.50 + x cm. Surface colour: 10YR 8/3 very pale brown-5YR 5/4 reddish brown. Break: 10YR 7/3 very pale brown. Technical details: throwing lines inside. Surface treatment: smoothed on the wheel. Deformed.

Cypriote fine ware

White Painted IV (or V)

No. 371: bowl (Fig. 40:28), Inv. No. P0517A (Drawing No. 0226)

WPMO	VI?	W ₂	---	ox.	3
------	-----	----------------	-----	-----	---

Body sherd. Md: ca. 22.00 + x cm; Wd: 0.70 cm; H₁: 2.00 + x cm. Surface colour: 2.5YR 8/2 pale yellow slip. Break: 7.5YR 6/4 light yellowish brown. Decoration: painted; 2 horizontal lines inside, 1 mm wide, and a thick horizontal band outside; colour: 2.5YR 4/1 dark grey. Surface treatment: polished, low lustre.

White Painted II?

No. 372: jar (Fig. 40:28), Inv. No. P1031A (Drawing No. 0700)

WPMO	VI.TG 04	W ₂	---	ox.	3
------	----------	----------------	-----	-----	---

Body sherd. Md: ca. 20.00 cm; Wd: 0.50 cm; H₁: 6.90 + x cm. Surface colour: 2.5YR 8/3 pale yellow slip. Break: 5YR 5/8 yellowish red. Technical details: throwing lines inside. Decoration: horizontally painted lines, 1-3 mm wide, 7.5YR 5/3 brown. Surface treatment: polished, low lustre.

White Painted II

No. 373: jar (Fig. 40:28), Inv. No. P1176A (Drawing No. 0701)

BPMO	VI.TG 04	W ₂	---	ox.	3
------	----------	----------------	-----	-----	---

Body sherd. Md: 18.00 cm 1/6; Wd: 0.70-1.00 cm; H₁: 5.50 + x cm. Surface colour: 10YR 7/3 very pale brown slip. Break: 10YR 6/4 light yellowish brown. Technical details: throwing lines inside. Decoration: horizontally painted lines, 1-3 mm wide, 7.5YR 4/2 brown. Surface treatment: polished, low lustre.

Black-on-Red II (IV) ware?

No. 374: juglet, Inv. No. P0015A (Drawing No. 0221)

RPMO	VI?	W ₂	---	ox.	3
------	-----	----------------	-----	-----	---

Rim and neck fragment; everted articulated exterior rim, rounded lip. Rd: 4.50 cm; Nd: 2.60 cm; Wd: 0.70 cm; H₃: 2.10 + x cm. Surface colour: 10YR 4/8 red slip. Break: 7.5YR 6/4 light brown. Decoration: ---. Rim and neck partially red polished. Surface treatment: polished, low lustre.

Black-on-Red ware

No. 375: juglet (Fig. 40:29), Inv. No. P0220A (Drawing No. 0121. F19)

RPMO	VI.TG 04	W ₂	---	ox.	3
------	----------	----------------	-----	-----	---

Body sherd. Md: ca. 15 + x cm; Wd: 0.25 cm; H₁: 2.05 + x cm. Surface colour: 2.5YR 5/8 red slip. Break: 5YR 6/6 reddish yellow. Technical details: throwing lines inside. Decoration: a horizontally painted band, 2.5YR 2.5/3 very dusky red. Surface treatment: polished, high lustre.

No. 376: juglet (Fig. 40:29), Inv. No. P0807A (Drawing No. 0950)

BPMO	VI.TG 04	W ₂	---	ox.	3
------	----------	----------------	-----	-----	---

Body sherd. Md: 9.00 cm 1/8; Wd: 0.30 cm; H₁: 0.80 + x cm. Surface colour: 10YR 7/4 very pale brown slip. Break: 10YR 8/3 very pale brown. Technical details: throwing lines

inside. Decoration: a painted circle, 1 mm wide, 10YR 4/2 dark greyish brown. Surface treatment: polished, low lustre.

No. 377: juglet or pilgrim flask?, Inv. No. P1190A (Drawing No. 0704)

Uncoated	VI.TG 40 f.	Ha ₂	---	ox.	3
----------	-------------	-----------------	-----	-----	---

Handle fragment; loop handle; Hd: 0.60 x 0.60 cm; round in section; 1; single strap. Surface colour: 7.5YR 6/4 light brown. Break: 7.5YR 2.5/1 black core; 7.5YR 5/4 brown oxidation zones. Surface treatment: smoothed by hand.

No. 378: jar (Fig. 40:29), Inv. No. P0200A (Drawing No. 0054.F12)

RPMO	VI.TG 04	W ₂	---	ox.	3
------	----------	----------------	-----	-----	---

Body sherd. Md: 10.00 + x cm; Wd: 0.30 cm; H₁: 2.80 + x cm. Surface colour: 2.5YR 5/8 red slip. Break: 10YR 8/4 very pale brown. Technical details: throwing lines on the interior. Decoration: a horizontally painted line, 5 mm wide, 2.5YR 2.5/1 reddish black. Surface treatment: polished, medium lustre. *Find No. 002.*

No. 379: juglet (Fig. 40:29), Inv. No. P0394A (Drawing No. 0656)

RS	VI.TG 43	W ₂	---	med.	3
----	----------	----------------	-----	------	---

Body sherd. Md: 10.00 cm 3/32; Wd: 0.50 cm; H₁: 2.60 + x cm. Surface colour: 2.5YR 4/6 red. Break: 5YR 6/6 reddish yellow core; 7.5YR 7/6 reddish yellow oxidation zones. Technical details: throwing lines outside. Decoration: ---. Surface treatment: smoothed on the wheel.

No. 380: jug (Fig. 40:29), Inv. No. P0842A (Drawing No. 0657)

Uncoated	VI.TG 40	W ₂	---	med.	3
----------	----------	----------------	-----	------	---

Neck and rim fragment; everted direct rim, trimmed lip. Rd: 8.00 cm 1/8; Wd: 0.45 cm; H₁: 2.90 + x cm. Surface colour: 7.5YR 6/4 light brown. Break: 10YR 6/1 grey core; 10YR 7/2 light grey oxidation zones. Technical details: throwing lines inside. Surface treatment: smoothed on the wheel. Eroded.

Cypriote household ware

No. 381: jar (Fig. 40:29), Inv. No. P1068A (Drawing No. 0387)

Uncoated	VI.TG 44	W ₂	---	ox.	3
----------	----------	----------------	-----	-----	---

Rim, neck and body fragment; everted direct rim, round lip. Rd: 4.00 cm 1/16; Nd: 4.00 cm 1/16; Md: ca. 5.10 cm; Wd: 0.50 cm; H₁: 2.00 + x cm; H₃: 1.40 cm. Surface colour: 7.5YR 8/6 reddish yellow. Break: 7.5YR 8/6 reddish yellow. Technical details: throwing lines inside. Surface treatment: smoothed on the wheel.

No. 382: juglet?, Inv. No. P0537A

Uncoated	VI.TG 40 f.	W ₂	---	ox.	3
----------	-------------	----------------	-----	-----	---

Body sherd. Wd: 0.30 cm.

No. 383: jug, Inv. No. C-0521 [147]

Uncoated	VI.TG 04	W ₂ + Ha ₂			
----------	----------	----------------------------------	--	--	--

Neck and handle fragment; compound neck; loop handle. Wd: 0.50 cm; H₁: 3.90 + x cm; Hd: 1.30 x 0.80 cm; 1; single strap; throwing lines inside; smoothed. Another, Hd: 2.50 x 1.40 cm.

No. 384: amphora, VI.TG 04, body sherds: 4.00 dm².

No. 385: amphora (Fig. 40:29), Inv. No. C-0521 [087]

Uncoated	VI. TG 40	W ₂
----------	-----------	----------------

Rim sherd; vertical articulated interior rim; modelled lip; Rd: 10.00 cm 5/32; Wd: 0.50 cm; H₁: 3.00 + x cm. Throwing lines inside; smoothed on the wheel. Another: Rd: 10.00 cm 5/32.

No. 386: amphora, Inv. No. C-0135 [009]

Uncoated	VI.TG 40	Ha ₂
----------	----------	-----------------

Handle fragment; vertical loop handle; Hd: 2.00 x 1.70 cm; single strap; smoothed.

No. 387: amphora, VI.TG 40, body sherds: 0.40 dm².

No. 388: amphora, VI.TG 42, body sherds: 1.40 dm².

No. 389: amphora, VI.TG 44, body sherds: 0.40 dm².

Aegean fine ware

No. 390: juglet, Inv. No. C-0001 (2) [024]

RP	VII.TG 13 (Samos)	Ha ₂ + W ₂
----	-------------------	----------------------------------

Handle and rim fragment; handle from the rim. Rd: ca. 2.00 cm; Hd: 1.30 x 0.90 cm; single strap; red slipped polished.

White Painted ware

No. 391: jar? (Fig. 40:29), Inv. No. P0392A (Drawing No. 0231)

WPMO	VII.?	W ₂	---	ox.	3
------	-------	----------------	-----	-----	---

Body sherd. Md: 20.00 x cm; Wd: 0.60 cm; H₁: 2.60 + x cm. Surface colour: 10YR 8/4 very pale brown. Break: 5YR 6/6 reddish yellow. Technical details: throwing lines inside. Decoration: a horizontally painted band, 10R 5/6 red. Surface treatment: polished, low lustre.

Mixed style

White Painted/Bichrome?

No. 392: bowl (Fig. 40:29), Inv. No. P0712A (Drawing No. 0302)

BPMO/WPBI?	VII.TG 48 (Samian)	W ₂	---	ox.	3
------------	--------------------	----------------	-----	-----	---

Body sherd. Md: 13.00 + x cm; Wd: 0.50 cm; H₁: 3.70 + x cm. Surface colour: slip 10YR 7/4 very pale brown slip on the exterior and 5YR 7/4 pink slip on the interior slip. Break: 5YR 6/6 reddish yellow. Decoration: painted; a horizontal band 16 mm wide (exterior at major diameter); vertical lines outside and horizontal lines inside, 2 mm wide; colour: 5YR 4/1 dark grey; the red decoration is not preserved. Surface treatment: polished, low lustre.

Black-on-Red ware

No. 393: juglet (Fig. 40:30), Inv. No. P2005A (Drawing No. 0441)

RPMO	VII.TG 45	W ₂	---	ox.	3
------	-----------	----------------	-----	-----	---

Rim, neck and body fragment; everted direct rim, pinched rim. Rd: ca. 2.50 cm; Nd: 2.00 cm 5/32; Wd: 0.40 cm; H₁: 3.50 + x cm. Surface colour: 2.5YR 4/6 red slip. Break: 2.5YR 5/4 reddish brown. Technical details: throwing lines inside. Decoration: a painted band around the neck, 4 mm wide, and on the rim, inside, 2.5YR 3/1 dark reddish grey. Surface treatment: polished, low lustre. *Find No. 006.*

No. 394: juglet (Fig. 40:30), Inv. No. P0849A (Drawing No. 0388)

RPMO	VII.TG 39	W ₂	---	ox.	3
------	-----------	----------------	-----	-----	---

Body sherd. Md: 7.00 cm; Wd: 0.40 cm; H₁: 1.10 + x cm. Surface colour: 2.5YR 5/8 red slip. Break: 5YR 7/6 reddish yellow. Technical details: throwing lines inside. Decoration: four horizontally painted lines, 1 mm wide, 2.5YR 3/4 dark reddish brown. Surface

treatment: polished, low lustre.

No. 395: juglet (Fig. 40:30), Inv. No. P0778A (Drawing No. 0391)

RPMO	VII.TG 39	W ₂	---	ox.	3
------	-----------	----------------	-----	-----	---

Body sherd. Md: 6.00 cm; Wd: 0.30 cm; H₁: 2.80 + x cm. Surface colour: 2.5YR 5/8 red polished slip. Break: 2.5YR 6/8 light red. Technical details: throwing lines inside. Decoration: four painted lines: 0.6-1.0 mm, and a circle, 2.5YR 3/1 dark reddish grey. Surface treatment: polished, medium lustre.

No. 396: juglet, Inv. No. P1182A

RPMO	VII.TG 45	W ₂	W	ox.	3
------	-----------	----------------	---	-----	---

Base fragment; flat base. Bd: 3.00 cm; Wd: 0.40 cm; H₁: 4.00 + x cm. Surface colour: 10R 5/6 red slip. Break: 10R 5/6 red. Decoration: ---. Surface treatment: polished, high lustre.

Black-on-Red II (IV)

No. 397: juglet (Fig. 40:30), Inv. No. P0204A (Drawing No. 0057. F13)

RPMO	VII.TG 39	W ₂	---	ox.	3
------	-----------	----------------	-----	-----	---

Body sherd. Md: 10.00 cm; Wd: 0.30 cm; H₁: 2.90 + x cm. Surface colour: 2.5YR 5/8 red slip. Break: 2.5YR 6/8 red. Technical details: very fine throwing lines on the interior. Decoration: horizontally painted lines, 2.5YR 2.5/1 reddish black. Surface treatment: polished, medium lustre. *Find No. 009.*

No. 398: juglet (Fig. 40:30), Inv. No. P2004A (Drawing No. 0655)

RPMO	VII.TG 39	---	W ₂	ox.	3
------	-----------	-----	----------------	-----	---

Body sherd. Md: 5.00 cm 5/32; Wd: 0.40 cm; H₁: 2.00 + x cm. Surface colour: 10R 5/8 red slip. Break: 7.5YR 8/6 reddish yellow and 2.5YR 7/6 light red. Technical details: throwing lines inside. Decoration: nine horizontally painted lines, 0.8-1 mm wide, 5YR 3/3 dark reddish brown. Surface treatment: polished, lustre low. *Find No. 022.*

No. 399: juglet (Fig. 40:30), Inv. No. P0844A (Drawing No. 0654)

RPMO	VII.TG 45	Ha ₂	---	ox.	3
------	-----------	-----------------	-----	-----	---

Handle fragment; Hd: 0.80 x 0.55 cm; 1; single strap. Surface colour: 2.5YR 7/6 light red slip. Break: 2.5YR 5/8 red. Decoration: a painted band, 2.5YR 2.5/1 black. Surface treatment: polished, matte lustre.

No. 400: juglet (Fig. 40:30), Inv. No. 7102A (Drawing No. 0529)

BPMO	VII.TG 45	W ₂	---	ox.	3
------	-----------	----------------	-----	-----	---

Body sherd; Md: 10.00 + x cm; Wd: 0.45 cm; H₁: 2.30 + x cm. Surface colour: 7.5YR 4/3 brown slip. Break: 7.5YR 5/3 brown. Technical details: Throwing lines inside. Decoration: two concentric painted circles and horizontal bands, 7.5YR 4/1 dark grey. Surface treatment: polished, high lustre.

No. 401: juglet (Fig. 40:30), Inv. No. P1067A (Drawing No. 0660)

WP	VII.TG 39	W ₂	---	med.	3
----	-----------	----------------	-----	------	---

Neck and body fragment. Nd: 4.00 cm 1/2; Md: ca. 8.10 cm; Wd: 0.40 cm; H₁: 3.10 + x cm. Surface colour: 5YR 6/6 reddish yellow slip. Break: 5YR 6/1 grey core; 7.5YR 7/6 reddish yellow and 5YR 6/6 reddish yellow oxidation zones. Technical details: throwing lines inside. Surface treatment: polished, low lustre.

No. 402: juglet (Fig. 40:31), Inv. No. P0692A (Drawing No. 0303)

WP	VII.TG 46 (Chian)	W ₂	base finished on the wheel	ox.	3
----	-------------------	----------------	----------------------------	-----	---

Nearly complete; no rim preserved; Akhziv type, ring base (R₃). Nd: 4.00-4.40 cm; Md: 9.00 cm; Wd: 0.80 cm; H₁: 15.00 + x cm; H₂: 4.00 cm; H₃: 5.20 + x cm; Hd: 0.90-1.20 x 1.00 cm; 1; single strap. Surface colour: 5YR 6/6 reddish yellow slip. Break: 5YR 6/6 reddish yellow. Technical details: applied handle from neck to shoulder; very thick walls. Surface treatment: polished, low lustre. Incrustations on the exterior surface. *Find No. 001.*

No. 403: jug (Fig. 40:32), Inv. No. P0691A (Drawing No. 0303)

RP	VII.TG 46 (Chian)	W ₂	base finished on the wheel	ox.	3
----	-------------------	----------------	----------------------------	-----	---

Nearly complete, fragmentary; no rim preserved; Akhziv type, ring base (R₃). Nd: 3.00-3.70 cm; 4.00 cm 1/8; Md: 9.50 cm; Wd: 0.50 cm; H₁: 15.00 + x cm; H₂: 4.00 cm; H₃: 6.00 + x cm; Hd: 1.30 x 1.20 cm; 1; single strap. Surface colour: 2.5YR 6/6 light red slip. Break: 5YR 5/4 reddish brown. Technical details: applied handle from neck to shoulder. Surface treatment: polished, low lustre. Eroded; incrustations on the exterior surface. *Find No. 002.*

No. 404: jug (Fig. 40:33), Inv. No. P0067A (Drawing No. 0059)

RPMO	VII.TG 45	W ₂	---	ox.	3
------	-----------	----------------	-----	-----	---

Body sherd. Md: 10.00 cm; Wd: 0.21 cm; H₁: 1.35 + x cm. Surface colour: 2.5YR 6/4 weak red; 10R 4/6 red slip. Break: 2.5YR 6/6 red. Technical details: throwing lines inside. Decoration: horizontally painted lines, 10R 3/2 dusky red. Surface treatment: polished; high lustre.

No. 405: juglet? (Fig. 40:33), Inv. No. P2003A (Drawing No. 0928)

RP	VII.TG 39	W ₂	---	med.	3
----	-----------	----------------	-----	------	---

Body sherd. Md: 6.00 cm 1/16; Wd: 0.30 cm; H₁: 1.80 + x cm. Surface colour: 10R 6/6 light red slip. Break: 5YR 7/6 reddish yellow and 2.5YR 7/6 light red. Technical details: throwing lines inside. Decoration: ---. Surface treatment: polished. *Find No. 009.*

No. 406: jug (Fig. 40:33), Inv. No. P0732A (Drawing No. 0662)

BPMO	VII.TG 39	W ₂	---	med.	3
------	-----------	----------------	-----	------	---

Neck and rim fragment; everted direct rim, round lip. Rd: 5.00 cm 7/32; Wd: 0.40 cm; H₃: 2.10 + x cm. Surface colour: 10YR 8/4 very pale brown slip. Break: 10YR 5/1 grey core; 10YR 7/4 very pale brown oxidation zones. Technical details: throwing lines inside. Decoration: a red painted band?. Surface treatment: polished, low lustre.

No. 407: jar (Fig. 40:33), Inv. No. P0207A₁₋₂ (Drawing No. 0186)

WPMO	VII.TG 46 (Chian)	W ₂	---	ox.	3
------	-------------------	----------------	-----	-----	---

Rim sherd; everted articulated exterior rim, round lip. Rd: 5.00 cm; Nd: 2.90 cm; Wd: 0.35 cm; H₁: 3.80 + x cm. Surface colour: 5YR 7/6 pink slip. Break: 5YR 5/3 reddish grey. Technical details: throwing lines inside. Decoration: a painted band on the rim and neck, 10R 5/6 red. Surface treatment: polished.

Aegean household ware

No. 408: juglet, Inv. No. C-0001 (2) [0001]

Uncoated	VII.TG 13 (Samos)	W ₂	W
----------	-------------------	----------------	---

Base fragment; ring base (R₃). Bd: 3.00 cm 1/2; Wd: 1.00 cm; H₁: 1.38 + x cm; throwing lines inside; smoothed on the wheel.

No. 409: jar, Inv. No. P0201A (Drawing No. 0211)

RS	VII.TG 39	W ₂	base finished on the wheel	ox.	2
----	-----------	----------------	----------------------------	-----	---

Base fragment; ring base (R₃). Bd: 6.50 cm 1/2; Wd: 0.50 cm; H₁: 1.08 + x cm. Surface

colour: 10R 5/4 red slip. Break: 7.5YR 7/4 pink. Surface treatment: smoothed on the wheel.

No. 410: jar?, Inv. No. C-0379 [016]

Uncoated	VII.TG 45	W ₂
----------	-----------	----------------

Rim sherd; inverted. Rd: 6.00 cm 3/16; Wd: 0.65 cm; H₁: 1.80 + x cm; throwing lines inside; smoothed on the wheel.

No. 411: amphora (Fig. 40:33), Inv. No. P0527A (Drawing No. 0237)

WS	VII.TG 13 (Samian)	W ₂	---	ox.	4
----	--------------------	----------------	-----	-----	---

Shoulder sherd. Md: ca. 16.00 + x cm; Wd: 1.80 cm; H₁: 1.00 + x cm. Surface colour: 7.5YR 7/4 pink slip. Break: 7.5YR 7/4 pink. Decoration: a painted band, 10R 4/4 weak red? Surface treatment: smoothed on the wheel.

No. 412: amphora, VII.TG 45, body sherds: 2.90 dm².

No. 413: amphora (Fig. 40:33), Inv. No. P0048A (Drawing No. 0001-2)

Coated	VII.TG 46 (Chian)	W ₂	---	ox.	3
--------	-------------------	----------------	-----	-----	---

Body sherd. Md: ca. 25.00 + x cm; Wd: 0.65 cm; H₁: 3.50 + x cm. Surface colour: 10YR 7/4 very pale brown slip. Break: 5YR 6/6 reddish yellow. Technical details: throwing lines on the interior. Decoration: a painted line around the base of the handle, 2.5YR 4/8 dark red. Surface treatment: smoothed on the wheel. Body sherds.

No. 414: amphora (Fig. 40:33), Inv. No. C-0521 [121]

Uncoated	VII.TG 48 (Samian)	W ₂
----------	--------------------	----------------

Shoulder fragment; "torpedo" type. Md: 26.00 cm; Wd: 0.70 cm; H₁: 4.20 + x cm.

No. 415: amphora, VII.TG 58, body sherds: 0.10 dm².

II.-Finds

Religion

No. 416: terracotta concubine (Fig. 40:34; Plate 13), Inv. No. F0179 + F0475 (Drawing No. 0107. F29). Nearly complete; clay; hand-made. 5.90-6.30 x 13.40 x 1.90-2.00 cm; colour: 2.5YR 4/4 reddish brown; red slip. Description: a plaque to be fixed on the wall; applied figure on a flat base; the body of the figurine has a frontal view, except the head that has a side view; the face has Nubian features. SCA No.1016. *Find No. 006.*

Amulets

No. 417: heart amulet (Fig. 40:35), Inv. No. F0494 (Drawing No. 0272). Complete; faience; moulded. 2.40 x 3.30 cm. Colour: 7.5YR 5/2 brown. Perforation: 1.5 mm; obverse: flat. SCA No. 2031. *Find No. 001.*

Bastet

No. 418: Bastet figurine (a pair) (Fig. 40:35; Plate 14), Inv. No. F0614 (Drawing No. 0440). Fragmentary; faience; moulded. 1.10 x 2.10 x 1.20 cm; colour: 10YR 7/4 very pale brown and Chart 1 for gley 7/5 light greenish. Description: a pair of Bastet goddesses in the form of cats; the deities are standing on a platform that seems to represent a lotus flower which is indicated by incised lines in zig zag form (a capitel from a column?); the lower part of the legs of both figurines are broken; a loop on the neck of the figurine, 2 mm of diameter. SCA No. 4017. *Find No. 004.*

Bes

No. 419: Bes figurine (Fig. 40:35), Inv. No. F0004 (Drawing No. 0027). Complete; faience; moulded. 2.35 x 0.95 x 0.75 cm; colour: Chart 1 for gley 8N white. Description: a Bes figurine with the feather crown; a loop on the neck; eroded. SCA No. 0982. *Find No. 009.*

No. 420: Bes (double) figurine (Fig. 40:35; Plate 15), Inv. No. F0158 (Drawing No. 0092. F24). Fragmentary; faience; moulded. 1.70 x 1.20 x 0.40 cm; colour: 10Y 8/1 light greenish grey. Description: the god is represented on both side of the object; standing on a platform, with the arms along the body; no headdress preserved. SCA No.1027. *Find No. 002.*

No. 421: Bes figurine (Fig. 40:35; Plate 16), Inv. No. F0515A (Drawing No. 0286). Fragmentary, mended; faience; moulded. 1.40 x 2.40 x 1.20 cm; colour: 5YR 4/1 dark grey. Description: only the head with the lower part of the feather crown and part of the dorsal pillar are preserved.

No. 422: Bes figurine (Fig. 40:35; Plate 17), Inv. No. F0034 (Drawing No. 0029). Fragmentary; bronze; melted. 2.50 x 4.20 cm x 1.40 cm; the lower part of the right leg is lacking; eroded. SCA No. 0997. *Find No. 001.*

Baboons

No. 423: baboon figurine (Fig. 40:35), Inv. No. F0064 (Drawing No. 0020. F6). Nearly complete; faience. 1.50 x 2.40 x 2.50 cm; colour: brown. Description: head of a baboon; a loop on the back. SCA No. 0990. *Find No. 031.*

No. 424: baboon figurine (Fig. 40:36; Plate 18), Inv. No. F0499 (Drawing No. 0275). Fragmentary, mended; faience; moulded. 5.20 x 2.10-1.90 x 2.00 cm; colour: 5YR 3/1 very dark grey, 5 YR 4/1 dark grey and 5 YR 5/1 grey. Description: a baboon sat on a platform with the arms raised up. SCA No. 2032.

Wdjats

No. 425: wdjat eye (Plate 19), Inv. No. F0006A (Drawing No. 0179). Fragmentary; faience; moulded. 0.70 cm x 1.10 cm x 0.40 cm. 5G 8/2, pale green; darker parts: 7.5YR 3/4 dark brown. Description: perhaps a curved lower arc part. Observations: faience very damaged. *Find No. 015.*

No. 426: wdjat eye (Plate 20), Inv. No. F0007A (Drawing No. 0170). Fragmentary; faience; moulded. 1.70 cm (right)/ 1.90 cm (left) x 1.20 cm x 0.50 cm. Colour: 10GY 8/1 light greenish grey; other lines and spot: 5YR 8/1 light greenish grey and 5YR 6/3 light reddish brown. Description: quadruple wdjat with longitudinal perforation. It is not a frontal face because it consists of two pairs of reversed eyes with the internal angles pointing outwards to emphasise the profiles. Observations: restored, abraded at the upper; right side, good quality faience. *Find No. 006.*

No. 427: wdjat eye (Plate 21), Inv. No. F0066A (Drawing No. 0169). Complete; faience; moulded. 1.20 x 1.30 x 0.40 cm. Colour: 10Y 8/1 light greenish grey; darker zones and lines: 7.5YR 4/2 brown. Description: left wdjat with longitudinal perforation; balanced square structure with gracile lines, without emphasis in the falcon's eye shape., incised lines. Observations: scarcely porous surface.

No. 428: wdjat eye (Plate 22), Inv. No. F0125A (Drawing No. 0179). Fragmentary, mended; faience; moulded. 1.30 cm (internal side) / 0.90 cm (external side) x 1.40 cm x 1.50 cm? Colour: 10Y 7/1 (light greenish grey). Description: left wdjat with longitudinal perforation; rectangular structure, imperfect manufacture, vertical protraction seems to be added later. Observations: restored, very wasted faience, rough surface, reverse abraded with spots and not smoothed. *Find No. 057.*

No. 429: wdjat eye (Plate 23), Inv. No. F0151 (Drawing No. 0037). Fragmentary; faience;

moulded. 1.60 cm x 1.80 cm / 2.20 cm x 0.50 cm. Colour: 5GY 7/1 light greenish grey; other lines: between 5YR and 5/2 y 4/2 reddish grey or dark reddish grey 10YR 8/1 very pale brown. Description: large right wdjat with longitudinal perforation; rectangular structure, peculiar shape with the eye internal angle very prominent and a large sclera and pupil, incised lines. Observations: good quality faience, little porous. Smoothed surface at the obverse and reverse. SCA No. 0979. *Find No. 084.*

No. 430: wdjat eye, Inv. No. F0152A. Faience; destroyed.

No. 431: wdjat eye (Plate 24), Inv. No. F0154A (Drawing No. 0089, F23). Fragmentary, mended; faience; moulded. 1.80 cm (internal side) / 1.50 cm (external side) x 1.90 cm / 2.10 cm x 0.50 cm. Colour: 10Y 8/1 light greenish grey. Description: right wdjat with longitudinal perforation; sketched details, uniform colour like a stone. Observations: restored, very wasted faience, rough surface; little glazed spot in the junction between the vertical protraction and the curved lower arc. *Find No. 005.*

No. 432: wdjat eye (Plate 25), Inv. No. F0174 (Drawing No. 0154, F28, and 0450).

Complete, mended; faience; moulded. 1.30 cm (internal side) / 1.20 cm (external side) x 1.50 cm / 1.40 cm (down) x 0.60 cm. Colour: 10YR 8/1 light greenish grey; darker parts: 10R 7/2 pale red. Description: right wdjat; closed rectangular structure, wider than high, with few irregularities in its shape. Incised lines to detach the central part of the eye and a triangular pupil. Observations: middle quality, granulated faience with considerable thickness according to its size. SCA No. 4025. *Find No. 004.*

No. 433: wdjat eye (Plate 26), Inv. No. F0295A (Drawing No. 0446). Complete; faience; moulded. 1.20 x 1.40 x 0.70 cm. Colour: 10GY 6/1 greenish grey; upper part of obverse and reverse: 10Y 7/1 light greenish grey; low part of obverse: 7.5YR 7/2 pinkish grey; dark lines: 7.5Y R 3/1 very dark grey. Description: right wdjat with longitudinal perforation; rectangular structure, much wider than high, definite shape, balanced lines; dark lines underline the sclera, making up line and superciliar arc. Observations: good quality faience, spots in the low part. *Find No. 008.*

No. 434: wdjat eye, Inv. No. F0440A. Fragmentary; faience; moulded. .50 x 2.20 x 0.60 cm Colour: 10YR 8/2 (very pale brown); and 10YR 3/2 (very dark greyish brown (the lines). Description: left wdjat (two separate fragments not). Observations: porous faience with holes. *Find No. 020.*

No. 435: wdjat eye (Plate 27), Inv. No. F0483 (Drawing No. 0270). Complete; faience; moulded. 2.00 x 1.50 x 0.40 cm Colour: 10YR 7/2 light grey and 10YR 3/1 very dark grey) Description: right wdjat, rectangular structure, higher than wide, with dark lines. Observations: complete, very fine faience. SCA No. 2030.

No. 436: wdajt?, Inv. No. F0595A. Fragmentary; faience. 1.00 x 0.70 cm Colour: 2.5Y 7/2 light grey. *Find No. 020.*

No. 437: wdajt?, Inv. No. F0596A. Fragmentary; faience; moulded. 1.00 x 1.10 cm. Colour: 5YR 4/1 dark grey. *Find No. 007.*

No. 438: wdjat eye (Fig. 40:37), Inv. No. F0658 (Drawing No. 0449). Complete; faience; moulded. 1.30 x 1.20 x 0.60 cm. Colour: 10YR 8/2 (very pale brown); perforation: 2 mm. SCA No. 4029. *Find No. 013.*

Scarabs and plaque seals

No. 439: scarab (Plate 28), Inv. No. F0650 (Drawing No. 0440; object sketch). Nearly complete; faience; moulded. 2.03 x 3.10 x 1.40 cm. Colour: 10YR 7/2 light grey.

Description: carved on both sides; the base has an incised hieroglyphic inscription, *di.t(i) p^ct hr nfr n^h*, with remains of colour (Chart 1 for glay 7/1 5GY light greenish grey); longitudinal perforation. Observations: broken in the upper left side and lower right side of the base. SCA No. 4030. *Find No. 001.*

No. 440: scarab (Fig. 40:37), Inv. No. F0655 (Drawing No. 0443; object sketch).

Complete; faience; moulded. 0.90 x 1.20 x 0.60 cm. Colour: 10YR 7/2 light grey. Description: carved on both sides, in base a very muddy drawing represents a scarab; longitudinal perforation (diameter: 0.14 cm). SCA No. 4033. *Find No. 010*.

No. 441: plaque seal (Plate 29), Inv. No. F0491 (Drawing No. 0266). Complete; faience; moulded. 1.50 x 1.10 x 0.60 cm. Colour: 7.5YR 5/3 brown. Description: deeply engraved on both sides; on the obverse *imn* (Maat feather + Montu figure + Aa12 sign); on the reverse the hieroglyphic group *mn imn*, with remains of red material? on the bottom; vertical perforation (diameter: ca 1.0 mm). SCA No.2031.

No. 442: scaraboid (Fig. 40:37), Inv. No. F0492A (Drawing No. 0271; object sketch). Complete; faience; moulded. 1.50 x 1.90 x 0.50 cm. Colour: 2.5Y 4/1 dark grey- 2.5Y 5/1 greyish brown. Description: oval shape with incised lines on the back; no decoration or inscription is preserved on the base; longitudinal perforation. *Find No. 005*.

Religion

No. 443: fragment of a figurine?, Inv. No. F0223A (Drawing No. 0113. F30).

Faience. 3.00-2.60 x 4.00-2.90 x 1.30 cm; colour: 5G 7/1 light greenish grey. *Find No. 001*.

No. 444: plaque? (Fig. 40:37), Inv. No. F0436A (Drawing No. 0619). Complete; faience; moulded. 4.40 x 2.60-2.30 x 1.60-1.20 cm; colour: 7.5YR 5/2 (brown). Description: incised decoration or inscriptions? *Find No. 002*.

Figurative art

No. 445: head of a female figurine (Fig. 40:38; Plate 30), Inv. No. F0150 (Drawing No. 0087. F33). Fragmentary, mended; faience; moulded. 3.00 x 1.50-1.60 x 0.40 cm; colour: Chart 1 for gley 5G 7/1 (light greenish grey). Description: the figure holds with both hands a basket on the head, which is covered by a net. SCA No.1020. *Find No. 001*.

No. 446: terracotta figurine (Plate 31), Inv. No. F0292 (Drawing No. 0288). Fragmentary; clay; hand-made. 9.60 x 4.40-5.40- 4.60 x 2.80 cm. Colour: 10R 4/4 weak red - 3/4 dusky red. Description: flat-concave side view; a nude female figure, with the right arm crossed on the belly holding a lotus flower; the left arm is along the body; long hair; breast and belly enlarged; eroded face; the lower part is broken; a hole at the back behind the neck for hanging. SCA No. 2019. *Find No. 017*.

No. 447: terracotta figurine (Fig. 40:38), Inv. No. F0001 (Drawing No. 0043. F10). Fragmentary; clay; hand-made. 6.70 x 5.36 x 3.40 cm; colour: 10R 5/6 red slip. Description: the legs and part of the body of a rider on the back of a horse? SCA No. 0973. *Find No. 034*.

No. 448: terracotta figurine (Fig. 40:38), Inv. No. F0840A (Drawing No. 0931). Fragmentary; clay; hand-made. 3.50 x 3.00 x 9.10 cm; colour: 10R 5/6 red slip. Description: the legs and part of the body of a rider on the back of a horse?

No. 449: terracotta figurine (Fig. 40:38), Inv. No. F0181 (Drawing No. 0104. F22). Fragmentary; clay; hand-made. 2.10-1.80 x 2.50-1.80 x 1.80-1.20 cm; colour: 2.5YR 3/6 dark red. Description: the head and the neck of the horse and the hands of the rider are preserved. SCA No.1013. *Find No. 004*.

No. 450: terracotta zoomorphic figurine (Fig. 40:39), Inv. No. F0302 (Drawing No. 0289). Fragmentary; clay; hand-made. 7.40-4.90 x 2.80-2.60 cm; colour: 2.5YR 5/6 red. Description: the ears, legs and tail are lacking; a horse? SCA No. 2020. *Find No. 022*.

No. 451: terracotta zoomorphic figurine (Fig. 40:39), Inv. No. F0018 (Drawing No. 0044). Fragmentary; clay; hand-made. 5.30 x 4.50 x 2.80 cm; colour: 7.5YR 6/4 light brown; 10R 5/8 red slip. Description: fragment of an animal figure, probably a camel; the head, legs and coil are lacking. SCA No. 0972. *Find No. 014*.

No. 452: terracotta zoomorphic figurine (Fig. 40:39), Inv. No. F0170 (Drawing No. 0102. F31). Fragmentary; clay; hand-made. 3.60 x 1.80-2.90 x 1.20 cm; colour: 5YR 6/3 light reddish brown. Description: only the back of an animal is preserved. SCA No. 1021. *Find No. 004.*

Personal objects

No. 453: spatula (Fig. 40:39), Inv. No. F0177A (Drawing No. 0931). Fragmentary; wood; hand-made. 3.80 x 1.20-0.30 x 0.20 cm. Smoothed on both surfaces. *Find No. 001.*

No. 454: bead, perforated, Inv. No. F1097A (before Inv. No. F0934B. Drawing No. 0925). Fragmentary; material: ?; colour: reddish orange. 1.90 x 1.20 x 1.00 cm. Primary form: flat pebble. Second use: cortex wholly reserved.

Faience beads

No. 455: bead (Fig. 40:39), Inv. No. F0003A (Drawing No. 0169). Complete; faience; moulded. 0.50 x 0.10 cm; colour: 7.5YR 8/2 pinkish white. Cylindrical shape; perforation: 1 mm.

No. 456: bead (Fig. 40:39), Inv. No. F0005A (Drawing No. 0170). Complete; chert? 1.90 x 1.70 cm; spherical shape; perforation: 3 mm. *Find No. 013.*

No. 457: bead (Fig. 40:39), Inv. No. F0037 (Drawing No. 0024). Complete; faience; moulded. 1.85 x 0.50 cm; colour: 10YR 8/1 white; cylindrical shape. SCA No. 0983. *Find No. 004.*

No. 458: bead (Fig. 40:39), Inv. No. F0038A (Drawing No. 0136. F26). Complete; alabaster. 0.70 x 0.40 cm. Double-hemispheric shape; perforation: 1 mm. *Find No. 005.*

No. 459: bead (Fig. 40:39), Inv. No. F0155A (Drawing No. 0090. F23). Complete; faience; moulded. 1.00 x 0.90 cm. Colour: 10R 8/1 white; spherical shape. *Find No. 006.*

No. 460: bead (Fig. 40:39), Inv. No. F0171 (Drawing No. 0110. F22). Complete; steatite. 0.70 x 1.00 cm. Spherical shape. SCA No. 1018.

No. 461: bead, Inv. No. F0286A. Fragmentary; bronze. 1.20 x 1.00 cm; conical shape. *Find No. 006.*

No. 462: bead, Inv. No. F0327. Complete; faience; moulded. 0.50 x 0.70 cm; colour: 2.5YR 4/3 reddish brown. Cylindrical shape; perforation: 2 mm. SCA No. 2041.

No. 463: bead, Inv. No. F0399A (Drawing No. 0622). Complete; faience; moulded. 0.60 x 0.20 cm; colour: light greenish grey. Cylindrical shape; vertical perforation in the middle. *Find No. 027.*

No. 464: bead (Fig. 40:39), Inv. No. F0482 (Drawing No. 0267). Complete; alabaster. 1.60 x 0.60-0.50 cm; cylindrical shape. SCA No. 2038.

No. 465: bead, Inv. No. F0484A (Drawing No. 0266). Complete; faience; moulded. 3.00 x 1.00 cm; colour: 7.5YR 6/3 light brown; cylindrical shape; horizontal perforation: 2 mm.

No. 466: bead, Inv. No. F0534A. Complete; shell. 1.40 x 0.90 x 0.70 cm. *Find No. 001.*

No. 467: bead, Inv. No. F0591 (Drawing No. 0442). Fragmentary; alabaster? 0.50-0.80 x 1.50 cm; barrel-shaped bead; perforation: 2 mm. SCA No. 4014. *Find No. 005.*

No. 468: bead (Fig. 40:39), Inv. No. F0600A (Drawing No. 0456). Complete; faience; moulded. 1.20 x 0.80 cm; colour: 7.5YR 4/2 brown. Spherical shape; perforation: 3 mm. *Find No. 005.*

No. 469: bead (Fig. 40:39), Inv. No. F0609A (Drawing No. 0456). Fragmentary, mended; faience; moulded. 1.16 x 0.87 cm; colour: 2.5Y 7/4 pale yellow. Irregular shape; perforation: 3.9 mm. *Find No. 008.*

Recreation

No. 470: gaming piece? (Fig. 40:39), Inv. No. F0172A (Drawing No. 0111. F34). Fragmentary; faience; moulded. 2.10 x 1.10 x 0.30-0.60 cm; colour: 10YR 8/1 light

greenish grey. Semi-spherical shape in the part preserved. *Find No. 003.*

No. 471: sherd used as a gaming piece (Fig. 40:40), *Inv. No. F0062A* (Drawing No. 0129. F25). Complete; pottery. 3.80 x 3.20 x 1.20 cm; colour: 2.5YR 4/4 reddish brown. *Find No. 029.*

No. 472: sherd used as a gaming piece, *Inv. No. F0480A* (Drawing No. 0640). Complete; pottery. 3.60 x 3.90 x 1.00 cm; colour: 2.5YR 5/3 reddish brown.

No. 473: sherd used as a gaming piece, *Inv. No. F0471A* (Drawing No. 0622). Complete; pottery. 2.20 x 2.70 x 0.60 cm; colour: 5YR 4/3 (reddish brown). *Find No. 015.*

No. 474: sherd used as a gaming piece (Fig. 40:40) , *Inv. No. F0134A* (Drawing No. 0097. F23). Complete; pottery. 2.60-2.80 x 1.20 cm; colour: 10R 5/6 red. *Find No. 002.*

No. 475: sherd used as a gaming piece (Fig. 40:40), *Inv. No. F0059A* (Drawing No. 0128. F28). Complete; pottery. 3.30 x 3.10 x 1.10 cm; colour: 2.5YR 4/4 reddish brown. *Find No. 026.*

No. 476: sherd used as a gaming piece (Fig. 40:40), *Inv. No. F0060A* (Drawing No. 0130. F25). Complete; pottery. 2.80-2.50 x 0.80 cm; colour: 2.5YR 4/4 reddish brown. *Find No. 027.*

No. 477: sherd used as a gaming piece, *Inv. No. F0353A*. Complete; pottery. 3.30 x 3.60 x 1.10 cm; colour: 2.5YR 4/4 (reddish brown).

No. 478: sherd used as a gaming piece, *Inv. No. F1032A*. Complete; pottery. *Find No. 044.*

No. 479: sherd used as a gaming piece, *Inv. No. F1033A*. Complete; pottery. *Find No. 043.*

Architectonic feature

No. 480: socket (Fig. 40:40), *Inv. No. F0539A* (Drawing No. 0334). Complete; limestone. Weight: 1.419.00 gr. 16.00 x 13.50 x 7.20 cm. Primary form: cobble. Comments: perhaps discarded because the hole is double. Degree of wear: 2-Medium. Wear type: friction. Wear marks: striations. Contact: 1. Surface configuration: concave. Stroke: circular. *Find No. 023.*

Net weights (for fishing)

No. 481: net weight (Fig. 40:41), *Inv. No. F0176A* (Drawing No. 0110. F34). Complete; lead; melted. 1.00 x 1.30-0.90 x 1.10 cm. U-shape, rectangular section. *Find No. 001.*

No. 482: net weight (Fig. 40:41), *Inv. No. F0188A* (Drawing No. 0114. F22). Complete, mended; lead; melted. 1) 2.40 x 1.60-1.10 x 1.60-.10; 2) 1.80 x 0.90 x 0.60 cm. U-shape, rectangular section. *Find No. 001.*

No. 483: net weight, *Inv. No. F0466A* (Drawing No. 0266). Complete; lead; melted. 2.60 x 1.80 x 1.30 cm. U-shape, rectangular section. *Find No. 010.*

No. 484: net weight (Fig. 40:41), *Inv. No. F0467A* (Drawing No. 0273). Complete; lead; melted. 1.80 x 2.60 x 1.10 cm. U-shape, rectangular section. *Find No. 019.*

No. 485: net weight (Fig. 40:41), *Inv. No. F0468A* (Drawing No. 0273). Complete; lead; melted. 2.00 x 1.60 x 1.40 cm. U-shape, rectangular section.

No. 486: net weight, *Inv. No. F0523A*. Fragmentary; bronze; melted. 1.80 x 1.70 x 1.20 cm. U-shape; broken in two parts. *Find No. 008.*

No. 487: net weight, *Inv. No. F0681A* (Drawing No. 0639). Fragmentary; lead; melted. 2.49 x 1.67 x 1.64 cm. U-shape, rectangular section. *Find No. 007.*

No. 488: net weight (Fig. 40:41), *Inv. No. F0737A* (Drawing No. 0640). Complete; lead; melted. 2.12 x 1.38 x 1.54 cm. U-shape, rectangular section. *Find No. 018.*

No. 489: net weight (Fig. 40:41), *Inv. No. F0746A* (Drawing No. 0622). Complete; lead; melted. 1.86 x 1.73 x 1.54 cm. U-shape, rectangular section. *Find No. 003.*

No. 490: net weight, *Inv. No. F0859A*. Fragmentary; lead.

No. 491: net weight (Fig. 40:41), Inv. No. F1021A (Drawing No. 0273). Fragmentary; lead; melted. 0.80 x 2.00 cm. U-shape, rectangular section.

Suspended weights

No. 492: net or loom weight? (Fig. 40:41), Inv. No. F0157A (Drawing No. 0091. F23). Fragmentary, mended; limestone. 3.00 x 2.50-4.00 x 1.50 cm. Domed shape; a stringing groove preserved; axial perforation: 1.00 cm. *Find No. 008.*

No. 493: loom weight (Fig. 40:42), Inv. No. F0162 (Drawing No. 0095. F32). Complete; clay. 5.20-5.10 x 1.50 cm. Colour: 2.5YR 4/4 dusky red; flat cylindrical shape. SCA No. 1017. *Find No. 007.*

No. 494: net or loom weight? (Fig. 40:42), Inv. No. F0496A (Drawing No. 0274). Complete; limestone. 5.60 x 5.40 x 1.70 cm. Manufacture technique: ground to shape; perforation: 1.00 cm; eroded. *Find No. 009.*

No. 495: loom weight, Inv. No. F0803A. Fragmentary; clay. 3.94 x 3.70 x 3.10 cm. Colour: 7.5 YR 5/4 -4/4 brown.

No. 496: net weight (Fig. 40:42), Inv. No. F1078A (before Inv. No. F0378A. Drawing No. 0273). Complete; limestone. 3.40 x 1.80 x 1.50 cm. Manufacture technique: ground to shape. Description: frontal view shape: geometric, rectangular; side view shape: flat-concave; two stringing grooves bad preserved. Function: fishing. *Find No. 001.*

No. 497: spindle whorl (Fig. 40:42), Inv. No. F0035A (Drawing No. 0179). Complete; clay. 3.00 x 2.70 x 1.20 cm. Colour: 2.5YR 3/3 dusky brown. Perforation: 0.30 cm. *Find No. 002.*

No. 498: spindle whorl (Fig. 40:43), Inv. No. F0169 (Drawing No. 0106. F29). Complete; clay. 1.50 x 2.90 cm Colour: 2.5YR 5/4 weak red. Spherical shape; perforation: 0.30 cm SCA No. 1015. *Find No. 004.*

No. 499: spindle whorl (2) (Fig. 40:43), Inv. No. F0495A₁₋₂ (Drawing No. 0273). Complete; clay. 1) 2.90 x 2.80 x 2.00 cm; 2) 2.90 x 2.80 x 1.60 cm. Colour: 1) 2.5YR 3/6 dark red; 2) 2.5YR 5/4 reddish brown. Perforation: 1) 0.40 cm ; 2) 0.30 cm. *Find No. 002.*

No. 500: spindle whorl (Fig. 40:43), Inv. No. F0685 (Drawing No. 0438). Complete; clay. 2.34 x 2.07 cm Colour: 2.5Y 4/1 dark grey. Nearly spherical; perforation: 0.50-0.42 cm SCA No. 4008. *Find No. 001.*

No. 501: spindle whorl (Fig. 40:43), Inv. No. F0770₁₋₂ (Drawing No. 0450). Complete; clay. 1) 2.92 x 1.96 cm; 2) 3.22 x 1.96 cm. Colour: 1) 7.5YR 5/4 brown; 2) 7.5YR 4/2 brown-7.5 YR 5/4 brown. Perforation: 0.3 cm. SCA No. 4007.

No. 502: spindle whorl, Inv. No. F1022A (before Inv. No. F0165A=F0165B). Complete; clay. 1.50 x 2.90 cm. Colour: 2.5YR 5/4 weak red. Spherical shape; burnt in some parts. *Find No. 004.*

Weights

No. 503: weight? (Fig. 40:44), Inv. No. F0124A (Drawing No. 0171). Complete; quartzite? 3.00 x 2.80 cm. Nearly spherical shape.

No. 504: weight? (Plate 32), Inv. No. F0221 (Drawing No. 1096). Complete; quartzite. 4.20 x 4.30 x 4.10 cm. Cubic shape. SCA No. 1028. *Find No. 002.*

No. 505: weight, Inv. No. F0437A. Fragmentary; limestone. 3.20 x 4.20 x 2.30 cm. Description: frontal view shape: geometric, conical; side view shape: double concave. *Find No. 001.*

No. 506: weight?, Inv. No. F0914A (before Inv. No. F0914B). Fragmentary; sandstone. 5.00 cm. *Find No.004.*

Tools

No. 507: bladelet?, Inv. No. F0950A. Complete; chert; burnt. 2.30 x 1.00 x 0.30 cm.

Manufacture technique: flaking.

No. 508: needle (Fig. 40:44), Inv. No. F0196A (Drawing No. 0132. F26). Fragmentary, mended; bone. 9.90 x 0.50 cm; colour: 5YR 6/3 (light reddish brown).

No. 509: hammer (Fig. 40:44), Inv. No. F1094A (before Inv. No. F0931B. Drawing No. 0923). Fragmentary; quartz. Weight: 81.00 gr. 6.60 x 4.20 x 1.80 cm. Primary form: flat pebble. Manufacture technique: by use. Degree of wear: 3-Hard. Wear type: percussion. Wear marks: crushed.

No. 510: hammer (Fig. 40:44), Inv. No. F1088A (before Inv. No. F0925B. Drawing No. 0921). Fragmentary; material?. Weight: 69.00 gr. 4.60 x 6.70 x 1.70 cm. Primary form: flattened pebble. Degree of wear: 2-Medium. Stroke: pecking.

No. 511: hammer (Fig. 40:44), Inv. No. F0919A (before Inv. No. F0919B. Drawing No. 0918). Complete; material? comments: volcanic, basic, heavy rock; colour: dark grey. Weight: 315 gr. 8.20 x 5.60 x 4.70 cm. Primary form: pebble. Degree of wear: 3-Hard. Wear type: percussion. Wear marks: crushed.

No. 512: slingstone (Fig. 40:45), Inv. No. F0142A (Drawing No. 1096). Complete. Weight: 185 gr. 5.70 x 6.10 x 5.50 cm. Raw material: ?; colour: grey. Primary form: cobble. Characteristics: modified. Wear marks: some striations?. Redisues: red spots. *Find No. 077.*

No. 513: fish hook (Fig. 40:45), Inv. No. F0029A (Drawing No. 0468). Bronze; melted; 5.50 x 3-70 x 0.80 cm. *Find No. 011.*

No. 514: undifferentiated tool, Inv. No. F0156 (Drawing No. 0088. F23). Complete; chert. 5.00 x 4.50 cm. Subspheric shape. SCA No.1029. *Find No. 007.*

No. 515: utilized cobble (Fig. 40:45), Inv. No. F0954A (Drawing No. 0940). Complete; basalt. Weight: 513 gr. 10.80 x 6.50 x 5.00 cm. Manufacture technique: by use. Degree of wear: 3-Hard. Wear type: friction and percussion.

No. 516: polisher (Fig. 40:45), Inv. No. F0075A (Drawing No. 1011). Complete; sandstone. Weight: 171.00 gr. 4.60 x 6.80 x 2.90 cm. Characteristics: very modified. Used surface: 3.00 x 5.20 cm. Degree of wear: 3-Hard. Wear type: abrasion. Wear marks: fine striations; polishing. Surfaces: 1. Surface configuration: flat. Surface texture: smoothed. Stroke: combination. *Find No. 001.*

No. 517: polisher? (Fig. 40:45), Inv. No. F0479A (Drawing No. 0347). Fragmentary; haematitic rock. Weight: 184.00 gr. 6.20 x 4.10 x 3.70 cm. Characteristics: one of the faces is smoothed. Used surface: 4.20 x 2.50 cm. Second use: weight?. Colour: 2.5YR 4/2 - 3/2 weak red and dusky red. Degree of wear: 1-Light. Wear type: polishing. Wear marks: fine striations. Stroke: perpendicular. *Find No. 001.*

No. 518: amphora stopper? (Fig. 40:46), Inv. No. F0180B (Drawing No. 0109. F22). Complete; limestone. 5.20 x 1.50 cm; cylindrical shape. Remains of an oily sediment. Observations: in the Abu Seifa exhibition room.

Grinding stones

No. 519: pestle (Fig. 40:46), Inv. No. F0040 (Drawing No. 0015). Complete; quartzite; pear-shaped; round base. 4.10 x 8.60 cm. Characteristics: surface eroded at the top and near the base. Function: for grinding cosmetic pigments? SCA No. 0974. *Find No. 007.*

No. 520: hand? (Fig. 40:47), Inv. No. F0168A (Drawing No. 0100. F30). Fragmentary; quartzite. 7.00 x 7.30 x 4.90 cm.

No. 521: hand (Fig. 40:47), Inv. No. F0220A (Drawing No. 1021). Complete; granite (reddish). Weight: 301.00 gr. 8.60 x 5.90 x 4.10 cm. Used surface: 6.90 x 4.50 cm. Primary form: cobble. Manufacture technique: ground to shape. Characteristics: slightly modified. Degree of wear: 3-Hard. Wear type: abrasion. Wear marks: polishing; striations. Surfaces: 1. Surface configuration: flat. Surface texture: coarse. Stroke: parallels. *Find No. 003.*

No. 522: hand (Fig. 40:47), Inv. No. F0984A (Drawing No. 0957). Fragmentary; burnt;

sandstone. 4.90 x 5.60 x 4.50 cm. Degree of wear: 1-Light. Wear marks: few light striations. Surface: 1. Surface configuration: flat. Surface texture: smoothed. Stroke: smoothed.

No. 523: netherstone (Fig. 40:48), Inv. No. F0501A (Drawing No. 0276). Complete; limestone. Weight: 765.00 gr. 9.20 x 12.30 x 4.90 cm. Used surface: 6.90 x 7.90 cm. Primary form: used cobble? Degree of wear: 2-Medium. Wear type: abrasion. Wear marks: deep striations; pecking. Surface: 1. Surface configuration: flat. Stroke: indeterminate.

No. 524: netherstone?, Inv. No. F1095A (before Inv. No. F0932B). Fragmentary; sandstone (reddish). 1.80 x 4.70 cm. Degree of wear: 3-Hard. Wear type: friction. Wear marks: light striations. Stroke: subparallel crosswise.

No. 525: netherstone (Fig. 40:48), Inv. No. F1098A (before Inv. No. F0935B. Drawing No. 0926). Complete; Aswan granite. Weight: more than 2 kg. 19.00 x 15.00 x 8.50 cm. Manufacture technique: shaped by flaking. Degree of wear: 2-Medium. Wear type: abrasion. Wear marks: light striations. Stroke: combination.

No. 526: saddle quern (Fig. 40:49), Inv. No. F0149A (Drawing No. 1015). Complete; quartzite. Weight: 1,929.00 gr. 15.00 x 13.40 x 6.20 cm. Primary form: block. Characteristics: slightly modified. Used surface: 13.40 x 11.40 cm. Comments: heterogeneous texture due to planes of weakness. Degree of wear: 2-Medium. Wear type: abrasion. Wear marks: striations. Surface: 1. Surface configuration: slightly convex. Surface texture: indeterminate. Stroke: perpendicular., *Find No. 082.*

No. 527: saddle quern, Inv. No. F0161A (Drawing No. 0096). Fragmentary; quartzite. 24.00 x 15.00 x 5.00 cm. *Find No. 003.*

No. 528: saddle quern (Fig. 40:49), Inv. No. F0167A (Drawing No. 1117). Complete; quartzite. Weight: 2 kg. 11.47 x 12.20 x 8.10 cm. Primary form: block. Characteristics: slightly modified. Used surface: 10.20 x 11.80 cm. Wear type: abrasion. Surface: 1. Surface configuration: slightly convex. *Find No. 002.*

No. 529: saddle quern (Fig. 40:50), Inv. No. F0236A (Drawing No. 0217). Fragmentary; quartzite? 11.20 x 5.90 cm. Primary form: block. Characteristics: slightly modified. Degree of wear: 2-Medium. Wear type: abrasion. Wear marks: polishing and slight striations. Surfaces: 1. Surface configuration: slightly convex.

No. 530: saddle quern (Fig. 40:50), Inv. No. F1099A (before Inv. No. F0936B. Drawing No. 0927). Complete; sandstone. Weight: >2 kg. 15.80 x 15.10 x 6.10 cm. Used surface: 12.80 x 14.10 cm. Manufacture technique: flaking. Characteristics: one margin battered. Degree of wear: 2-Medium. Wear marks: light striations. Surfaces: 2. Surface configuration: slightly convex. Surface texture: smoothed edge and coarse in the middle. *Find No. 021.*

No. 531: saddle quern (Fig. 40:51), Inv. No. F1076A (before Inv. No. F0161A. Drawing No. 0281). Complete; quartzite. Weight: 2.000 gr. 18.50 x 14.50 x 0.60 cm. Used surface: 12.70 x 13.00 cm. Primary form: cobble. Characteristics: slightly modified. Comments: weight more than 2 kg. Degree of wear: 2-Medium. Wear type: abrasion and percussion. Wear marks: striations; pecking. Surfaces: 1. Surface configuration: slightly convex. *Find No. 003*

No. 532: grinding stone, Inv. No. F0956A. Very fragmentary; material: ?. Surface texture: smoothed.

No. 533: grinding stone, Inv. No. F1089A (before Inv. No. F0926B). Very fragmentary; sandstone. Surface texture: smoothed. Wear marks: striations. Surface texture: smoothed.

Sharpeners

No. 534: sharpener (Fig. 40:51), Inv. No. F0028B (Drawing No. 0181). Complete; pumice. 4.00 x 2.80 x 6.30 cm. Wear type: friction; wear marks: incised grooves on the surface. Observations: in the Abu Seifa exhibition room. *Find No. 009.*

No. 535: sharpener, Inv. No. F0089A (Drawing No. 0105). Fragmentary; limestone. 5.70 x 3.50 x 1.00 cm.

No. 536: sharpener (Fig. 40:52), Inv. No. F0233A (Drawing No. 0172). Complete; pumice. 2.80-1.60 x 6.20 x 0.40 cm. *Find No. 009*.

No. 537: sharpener?, Inv. No. F0547A. Pumice. 4.10 x 3.30-1.10 x 2.00 cm.

No. 538: sharpener, Inv. No. F0570A (Drawing No. 0349). Fragmentary; pumice. Weight: 11 gr. 3.70 x 3.50 x 3.10 cm. Degree of wear: 2-Medium. Wear marks: grooves. Surfaces: 3. Contact: adjacent. Stroke: combination. *Find No. 004*.

No. 539: sharpener (Fig. 40:52), Inv. No. F0817A (Drawing No. 0453). Complete; pumice. 6.10 x 3.70 x 3.00 cm *Find No. 011*.

No. 540: sharpener, Inv. No. F0847A. Fragmentary, pumice.

Weapons

No. 541: arrow (Plate 33), Inv. No. F0511A (Drawing No. 0275). Complete; silex. 1.00 x 2.40 cm. Colour: 10YR 5/3 (brown). Description: stemmed projectile point (contracting stem).

No. 542: fragment of an object (Fig. 40:53), Inv. No. F1002A (Drawing No. 0946). Fragmentary; iron. 4.50 x 2.20 x 0.60 cm.

Objects of unknown use

Bronze

No. 543: fragment of an object, Inv. No. F0187A. Bronze. *Find No. 006*.

No. 544: fragment of an object, Inv. No. F0318A. Bronze. *Find No. 020*.

No. 545: fragment of an object, Inv. No. F0435A. Bronze. 1.10 x 0.80 x 0.50 cm. *Find No. 003*.

No. 546: fragment of an object (Fig. 40:53), Inv. No. F0842A (Drawing No. 0932). Bronze; melted. 4.00 x 1.00 cm; rounded section. *Find No. 003*.

No. 547: fragment of an object (Fig. 40:53), Inv. No. F1001A (Drawing No. 0946). Bronze; melted. 4.50 x 1.00 cm. Round section.

No. 548: fragment of an object (Fig. 40:53), Inv. No. F1018A (Drawing No. 0946). Bronze; melted. 3.00 x 1.00 x 0.50 cm.

Iron

No. 549: fragment of an object (a weapon?), Inv. No. F0113A (Drawing No. 0170). Iron; melted. 4.40 x 1.50-1.00 x 1.00-0.60 cm. *Find No. 045*.

No. 550: fragment of an object (Fig. 40:53), Inv. No. F0153A (Drawing No. 0098. F27). Iron; melted. 3.90 x 1.10 x 0.60 cm. *Find No. 004*.

No. 551: fragment of an object, Inv. No. F0301A. Iron; melted. 1) 2.30 x 1.10 x 0.90 cm; 2) 1.20 x 1.10 x 0.60 cm. *Find No. 021*.

Lead

No. 552: fragment of an object, Inv. No. F0724A. Lead. 1.90 x 1.00 x 0.80 cm; a net weight for fishing?

No. 553: fragments (2) of an object, Inv. No. F0753A. Lead. 1) 2.03 x 0.99 x 1.04 cm; 2) 0.81 x 0.46 x 0.43 cm; a net weight for fishing? *Find No. 002*.

Limestone

No. 554: fragment of an object (Fig. 40:53), Inv. No. F0518A (Drawing No. 0455). Limestone. 4.00 x 4.00 x 1.20 cm. *Find No. 006*.

No. 555: fragment of an object, Inv. No. F0666A. Limestone. 0.91 x 1.68 x 1.08 cm. *Find No. 014*.

Faience

No. 556: fragment of an object (Fig. 40:53), Inv. No. F0087A (Drawing No. 0139. F24). Faience; moulded. 1.40 x 1.40-0.90 x 0.90-0.60 cm; colour: Chart 1 for gley 5GY 7/1 (light greenish grey); remains colour, 2.5YR 2.5/2 very dusky red. *Find No. 004.*

No. 557: fragment of an object, Inv. No. F0175A. Faience. 0.80 x 1.00 cm; spherical shape.

No. 558: fragment of an object, Inv. No. F0185A. Faience; destroyed. *Find No. 005.*

No. 559: fragment of an object, Inv. No. F0340A. Faience; moulded. 1.20 x 0.80 x 0.50 cm. Colour: 7.5YR 6/3 (light brown). *Find No. 019.*

No. 560: fragment of an object, Inv. No. F0683A. Faience. 2.73 x 1.56 x 0.54 cm Colour: Chart 1 for gley 7/5G (pale green). *Find No. 019.*

No. 561: fragment of an object, Inv. No. F0838A. Faience. 0.60 x 0.30 x 1.20 cm.

No. 562: fragment of an object, Inv. No. F0597A. Faience. 1.80 x 0.90 cm. Colour: 10YR 6/2 (light brownish grey). *Find No. 017.*

No. 563: fragment of an object (Fig. 40:53), Inv. No. F1016A (Drawing No. 0946) Faience; moulded. 2.40 x 1.00 x 0.30 cm; light red.

No. 564: fragment of an object, Inv. No. F1038A. Faience. *Find No. 002.*

No. 565: fragment of an object, Inv. No. F1065A. Faience.

Raw material

No. 566: river pebble, Inv. No. F0944A. *Find No. 015.*

No. 567: pumice fragment, Inv. No. F0847A.

Products

No. 568: faience slag, Inv. No. F0745A. *Find No. 018.*

No. 569: faience slag, Inv. No. F1057A.

No. 570: faience slag, Inv. No. F1073A..

No. 571: slag, Inv. No. F0811A.

No. 572: slag, Inv. No. F0843A.

No. 573: slag, Inv. No. F0846A.

No. 574: flake as secondary use (Fig. 40:54), Inv. No. F0964A (Drawing No. 945). Fragmentary; chert. 3.90 x 4.10 x 0.90 cm. Comments: plain butt, 4.10 x 0.70 cm.

No. 575: flake, secondary (Fig. 40:54), Inv. No. F0965A (Drawing No. 0946). Complete; chert. 2.80 x 2.80 x 0.40 cm. Manufacture technique: knapping. Characteristics: diedric butt, 1.80 x 0.400. Cortex remains in 20%, 4 facets.

No. 576: flake, flat (Fig. 40:54), Inv. No. F0979A (Drawing No. 0952). Fragmentary; sandstone (reddish). 6.00 x 5.50 x 1.10 cm. Characteristics: perhaps from grinding stone in preparation. Comments: plain butt, 4.10 x 0.70 cm.

No. 577: chunk, Inv. No. F1112A (before Inv. No.0967B). Complete. 2.60 x 2.50 x 1.50 cm.

No. 578: core-like object Inv. No. F0960A. Incomplete; quartzite? 4.20 x 2.40 x 2.80 cm. Characteristics: cortex remains in 30% of the object.

No. 579: core-like object, Inv. No. F0967A. Complete; quartzite. 5.30 x 4.00 x 3.10 cm. Characteristics: cortex remains in 40%.

List of Figures and Plates (Area I) by Loci

AREA I		
LOCUS	FIGURE	PLATES
L0001	Fig. 40	Plates 13-33
L0007	Fig. 32	Plate 12
L0012 = L0209	Fig. 14	
L0014 = L0059 = L0081	Fig. 15	
L0015 = L0023	Fig. 16	
L0016 = L0183	Fig. 17	Plate 5
L0017	Fig. 18	Plates 6-9
L0029	Fig. 19	
L0035	Fig. 02	
L0038	Fig. 20	Plate 10
L0040 = L0043 = L0044	Fig. 03	Plates 2 and 2bis
L0047	Fig. 21	
L0050 = L0052	Fig. 04	
L0067	Fig. 33	
L0069	Fig. 22	
L0084	Fig. 23	
L0169	Fig. 24	
L0176	Fig. 25	
L0179	Fig. 26	
L0185	Fig. 34	
L0202	Fig. 35	
L0206	Fig. 36	
L0244	Fig. 37	
L0250	Fig. 29	
L0263 = L0222	Fig. 27	
L0266	Fig. 05	Plate 3
L0271 = L0283 = L0060	Fig. 30	Plate 11
L0273	Fig. 12	
L0237	Fig. 28	
L0274	Fig. 38	
L0289	Fig. 13	
L0294	Fig. 31	
L0314	Fig. 39	
L0316	Fig. 06	
L0319 = L0024	Fig. 07	Plate 4
L0345	Fig. 08	
L0352	Fig. 09	
L0353	Fig. 10	
L0356	Fig. 11	
L0371	Fig. 01	Plate 1

List of Figures and Plates (Area I)

AREA I		
FIGURE	PLATES	LOCUS
Fig. 01	Plate 1	L0371
Fig. 02		L0035
Fig. 03	Plates 2 and 2bis	L0040 = L0043 = L0044
Fig. 04		L0050 = L0052
Fig. 05	Plate 3	L0266
Fig. 06		L0316
Fig. 07	Plate 4	L0319 = L0024
Fig. 08		L0345
Fig. 09		L0352
Fig. 10		L0353
Fig. 11		L0356
Fig. 12		L0273
Fig. 13		L0289
Fig. 14		L0012 = L0209
Fig. 15		L0014 = L0059 = L0081
Fig. 16		L0015 = L0023
Fig. 17	Plate 5	L0016 = L0183
Fig. 18	Plates 6-9	L0017
Fig. 19		L0029
Fig. 20	Plate 10	L0038
Fig. 21		L0047
Fig. 22		L0069
Fig. 23		L0084
Fig. 24		L0169
Fig. 25		L0176
Fig. 26		L0179
Fig. 27		L0263 = L0222
Fig. 28		L0237
Fig. 29		L0250
Fig. 30	Plate 11	L0271 = L0283 = L0060
Fig. 31		L0294
Fig. 32	Plate 12	L0007
Fig. 33		L0067
Fig. 34		L0185
Fig. 35		L0202
Fig. 36		L0206
Fig. 37		L0244
Fig. 38		L0274
Fig. 39		L0314
Fig. 40	Plates 13-33	L0001

PART II: AREA II (EAST AND WEST SECTIONS)

Abstract. Area II (Plan I) was first explored in 1996 by means of slit trenches 1 m wide and 20 m long, which were dug until the first features or structures were found. They resulted in the discovery of two mud brick buildings, Building D (eastward; Plans V and VI) and Building C (westward; Plan V), both severely eroded and without preserved floors, measuring respectively 21 x 22 m and 20 x 22 m. At least Building C seems to have been a public structure. What remained of both structures were the basements, so that only the plan could be recovered.

Under Building D, another multiroomed mud brick structure was found, Building L (Plan VI), which was erected on a layer of clean foundation sand and went through several phases of utilization. One of its rooms was a magazine in which storage jars were kept.

The first utilization of Area II seems to have been quite similar to Level II in Area I, since the burnt remains of a flimsy structure (Building M) was spotted below Building L. The similarities with Building A (Plan II) in Area I (Plan I) are quite close. In the only foundation trench exposed from Building M, three doughnut-shaped loom weights had been placed, similar to those found in the foundation trench of Building A.

Area II was divided in two sections, East (Graphic II) and West (Graphics III to VI).

AREA II, EAST SECTION

LEVEL I: Strata below Building L

1.- Stratigraphic sequence

Since two superimposed buildings, L and D, were found and not removed, the underlying layers could only be dug in limited surfaces. The lowest one, **L1235**, is a massive sand rich in small sherds. A series of alternative laminae of sand and charcoal (**L1234**, **L1233** and **L1231**) followed. They are taken as an indication of the washing out of neighbouring, perhaps burnt, structures outside the excavated area and the redeposition and graded selection of the resulting sediments inside shallow bodies of stagnant water. The latter may have been ponds formed by the rain and/or the rising waters of the lagoon.

In Square BF/68 and SE of Square BF/69, the lower sequence was as follows:

L1420 is a carbonaceous layer with alternating dark patches and sand lenses. It seems to have formed in a waterlogged environment.

L1419 is a hearth, probably associated with three hewn limestone blocks that lay on a clayish surface. **L1410** and **L1413** were separated in excavation but seem to be one and the same sandy clay, which was deposited in a waterlogged medium.

Building M: **L1411**: narrow ditch (some 20 cm wide) that cut **L1410**, **L1413** and **L1420**. Its fill **-L1408-** was oxidized and carbonised, and contained an assortment of sherds and three fired clay doughnut-shaped loom weights (two complete and one broken), turned fragile by the humidity of the soil (Plate X). All this pottery was charcoal-stained. The nature and function of this ditch cannot be ascertained until more excavation is carried out; but it inevitably reminds to the foundation trench of Building A (Area I, Plan II), where similar weights³² were found embedded in burnt sediment.

A spread of broken vessels and large sherds, in a clayey matrix, follows (**L1409**). It might have been a refilling related to the erection Building L, but since it is rather limited in surface (some 70 cm at maximum) and could no be clearly separated from the pottery embedded in **L1408**, it was eventually associated with the latter.

The carbonaceous sediment that fills ditch **L1411** (Building M; Plate X) and the

³² L0356 (see p. 77 and Area I, L0356, Figs. 11:1 to 11:4, Nos. 4 to 19).

spread of pottery of L1409 seem to follow to the south, but here this complex of features is partly covered by overlying wall L1107 of Building L ([Graphic II](#)).

2.- Archaeological material

L1231 (Fig. 1)

I.- Pottery

Egyptian pottery

Nile silt clay

Fine ware

Egyptian painted ware

Black-on-Red slip ware

No. 1: jar (Fig. 1), Inv. No. P1141A (Drawing No. 0631)

RPMO	Nile B ₂	W ₂	---	re.	2-3
------	---------------------	----------------	-----	-----	-----

Body sherd. Md: 18.00 + x cm; Wd: 0.40 cm; H₁: 2.60 + x cm. Surface colour: 10R 5/6 red slip. Break: 5YR 4/1 dark grey. Technical details: made in parts; throwing lines inside. Decoration: four horizontally painted bands, 3 mm wide; 10R 3/1 dark reddish grey. Surface treatment: polished, low lustre.

Egyptian household ware

No. 2: jar? (Fig. 1), Inv. No. C-1309 (2) [008]

Uncoated	Nile B ₂	W ₂
----------	---------------------	----------------

Rim and wall fragment; flaring side walls; everted direct rim. Rd: 20.00 cm 3/32; Wd: 0.80 cm; H₁: 6.40 + x cm; smoothed on the wheel; eroded on the rim.

No. 3: jar? (Fig. 1), Inv. No. C-1309 (2) [003]

Uncoated	Nile C ₁	W ₂
----------	---------------------	----------------

Rim sherd; inverted direct rim Rd: 10.00 cm 1/16; Wd: 0.40 cm; H₁: 3.00 + x cm. Throwing lines inside; smoothed on the wheel; eroded outside. Another, Rd: 14.00 cm 3/32.

No. 4: jar (Fig. 1), Inv. No. C-1309 (2) [007bis]

Uncoated	Nile B ₂	W ₂
----------	---------------------	----------------

Rim sherd; inverted articulated interior and exterior rim, modelled lip. Rd: 18.00 cm 3/16; Wd: 0.80 cm; H₁: 4.50 + x cm. Throwing lines inside; smoothed on the wheel; eroded.

No. 5: jar (Fig. 1), Inv. No. C-1309 (2) [002]

Uncoated	Nile B ₂	W ₂
----------	---------------------	----------------

Rim sherd; vertical direct rim. Rd: 10.00 cm 1/8; Wd: 0.30 cm; H₁: 2.40 + x cm. Sharp throwing lines on the rim outside; throwing lines inside; smoothed on the wheel.

No. 6: jar (Fig. 1), Inv. No. C-1309 (2) [004]

Uncoated	Nile C ₁	W ₂
----------	---------------------	----------------

Rim sherd; everted direct rim. Rd: 10.00 cm 1/8; Wd: 0.40 cm; H₁: 2.10 + x cm. Throwing lines inside; smoothed on the wheel; eroded outside. Another, Nile B₂, Rd: 10.00 cm 3/32.

No. 7: storage jar (Fig. 1), Inv. No. C-1309 (2) [005]

Uncoated	Nile C ₁	W ₂
----------	---------------------	----------------

Rim sherd; inverted articulated exterior rim, modelled lip. Rd: 22.00 cm 3/32; Wd: 0.50

cm; H₁: 3.60 + x cm. Throwing lines inside; smoothed on the wheel; eroded. Others, Nile C₁, Rd: 22.00 cm 1/16, Rd: 22.00 cm 5/32.

No. 8: storage jar, handle fragment, Inv. No. C-1309 (2) [012], Nile B₂, Hd: 3.30 x 2.00 cm. Another, Nile C₂, Hd: 3.30 x 2.00 cm.

Pottery with special functions

No. 9: bakery tray, Inv. No. C-1309 (2)

Uncoated	Nile C ₂	W ₁
----------	---------------------	----------------

A rim fragment; eroded.

Egyptian marls

Household ware

No. 10: jar (Fig. 1), Inv. No. P1125A (Drawing No. 0636)

Uncoated	Marl A ₄	W ₂	---	ox.	3
----------	---------------------	----------------	-----	-----	---

Rim, shoulder and wall fragment, compound rim. Rd: 10.00 cm 3/16; Nd: 9.50 cm; Md: 18.07 + x cm; Wd: 0.60 cm; H₁: 4.50 + x cm; H₃: 3.40 cm. Surface colour: 10R 7/2 light red exterior; 5YR 6/4 light reddish brown interior. Break: 2.5YR 6/4 light reddish brown. Technical details: rilling lines on the body, and on the neck inside and outside. Surface treatment: smoothed on the wheel.

No. 11: amphora (Fig. 1), Inv. No. C-1309 (2) [010]

Uncoated	Marl A ₄ c.	W ₂
----------	------------------------	----------------

Rim sherd; vertical direct rim. Rd: 12.00 cm 1/8; Wd: 0.50 cm; H₁: 2.80 + x cm. Throwing lines inside; smoothed on the wheel; eroded.

No. 12: amphora (Fig. 1), Inv. No. C-1309 (2) [011]

Uncoated	Marl F	W ₂
----------	--------	----------------

Shoulder fragment; "torpedo" type. Md: 28.00 cm; Wd: 0.70 cm; H₁: 3.20 + x cm. Throwing lines inside; smoothed on the wheel; eroded.

No. 13: handle, Inv. No. C-1309 (2) [013], Marl F v.s.; Hd: 2.70 x 1.90 cm.

Body sherds, Nile B₂, Nile C₂, Marl A₄, Marl F.

b) North Sinai/South Palestine pottery

Household ware

No. 14: jar (Fig. 1), Inv. No. C-1309 (2) [009]

Uncoated	II.TG 10	W ₂
----------	----------	----------------

Rim sherd; slightly inverted direct rim. Rd: 8.00 cm 1/16; Wd: 0.30 cm; H₁: 2.70 + x cm. Throwing lines inside; smoothed on the wheel; eroded.

c) Imported pottery

Levantine household ware

No. 15: amphora, Inv. No. C-1309 (2) [014]

Uncoated	IV.TG 29	Ha ₂
----------	----------	-----------------

Handle fragment; Hd: 2.70 x 2.10 cm; eroded.

No. 16: amphora, = TD IV.02, body sherd.

II.- Finds**Product**

No. 17: slag, Inv. No. F0861A. *Find No. 019.*

L1233 (Fig. 2)**Finds****Personal object**

No. 1: bead (Fig. 2), Inv. No. F0667A (Drawing No. 0459). Complete; faience; moulded. D: 0.46 cm; colour: 7.5YR 8/2 pinkish white. Cylindrical shape; perforation: 2.2 mm. *Find No. 021.*

L1234 (Fig. 3)**I.- Pottery****Egyptian pottery****Nile silt clay****Household ware**

No. 1: jar (Fig. 3), Inv. No. C-1327 (2) [003]

Uncoated	Nile B ₂	W ₂
----------	---------------------	----------------

Rim sherd; inverted direct rim. Rd: 10.00 cm 1/8; Wd: 0.50 cm; H₁: 2.80 + x cm. Throwing lines inside; smoothed on the wheel; eroded.

No. 2: jar (Fig. 3), Inv. No. C-1327 (2) [001]

Uncoated	Nile B ₂	W ₂
----------	---------------------	----------------

Rim sherd; vertical direct rim. Rd: 10.00 cm 5/32; Wd: 0.60 cm; H₁: 3.40 + x cm. Throwing lines inside; smoothed on the wheel; eroded. Another, Rd: 10.00 cm 1/8.

Pottery with special functions

No. 3: tray (Fig. 3), Inv. No. P1115A (Drawing No. 0919)

Uncoated	Nile C ₂	Ha ₁	Ha	re.	2
----------	---------------------	-----------------	----	-----	---

Complete, fragmentary. D: ca. 50.00 cm; H₁: 6.50 cm. Surface colour: 5YR 5/3 reddish brown. Break: 5YR 3/1 very dark grey core; 5YR 5/3 reddish brown oxidation zones. Surface treatment: uneven.

Body sherds, Nile B₂ and Nile C₁: 6 dm².

b) Imported pottery,**Levantine household ware**

No. 4: amphora, Inv. No. C-1327 (2), IV.TG 51 (=TD IV.19), body sherd; 0.10 dm².

No. 5: amphora, Inv. No. C-1327 (2), IV.TG 53 (=TD IV.09), body sherd; 0.20 dm².

II.- Finds**Tool**

No. 6: sharpener (Fig. 3), Inv. No. F0828A (Drawing No. 0931). Fragmentary; pumice. 3.50 x 4.10 x 2.30 cm. Two grooves for sharpening.

Suspended weight

No. 7: loom weight (Fig. 3), Inv. No. F0913A (before Inv. No. F0913B. Drawing No. 1089). Complete; limestone. Weight: 76.00 gr. 5.80 x 5.50 x 2.00 cm. *Find No. 024.*

Object of known use

No. 8: fragment of an object (Fig. 3), Inv. No. F0651A (Drawing No. 0450). Faience; moulded. 0.66 x 1.15 x 0.50 cm; colour: Chart 1 for gley 8/5G (pale green). Perforation: 1.1 mm. *Find No. 028.*

L1235 (Fig. 4)**I.- Pottery****Egyptian pottery****Nile silt clay****Household ware**

No. 1: jar (Fig. 4), Inv. No. C-1316 [004]

Uncoated	Nile B ₂	W ₂
----------	---------------------	----------------

Rim sherd; inverted direct rim. Rd: 12.00 cm 1/8; Wd: 0.60 cm; H₁: 4.20 + x cm; throwing lines inside; smoothed on the wheel; eroded.

No. 2: jar (Fig. 4), Inv. No. C-1316 [003]

Uncoated	Nile B ₂	W ₂
----------	---------------------	----------------

Rim sherd; everted direct rim. Rd: 14.00 cm 1/4; Wd: 0.85 cm; H₁: 3.60 + x cm; throwing lines inside; smoothed on the wheel; eroded.

No. 3: jar, Inv. No. C-1316 [006]

Uncoated	Nile B ₂	W ₂ + Ha ₂
----------	---------------------	----------------------------------

Handle and wall fragment; vertical walls; attached horizontal loop handle; H₁: 5.30 + x cm; Hd: 1.90 x 1.20 cm; single strap; throwing lines inside; smoothed; eroded.

No. 4: jar, Inv. No. C-1316 [007]

Uncoated	Nile B ₂	W ₂	W
----------	---------------------	----------------	---

Base fragment; round base; Wd: 1.00-1.20 cm; H₁: 2.40 + x cm; throwing lines inside; smoothed on the wheel; eroded.

No. 5: storage jar (Fig. 4), Inv. No. C-1316 [001]

Uncoated	Nile B ₂	W ₂
----------	---------------------	----------------

Rim sherd; inverted articulated interior and exterior rim, modelled lip. Rd: 22.00 cm 3/32; Wd: 0.80 cm; H₁: 4.50 + x cm; throwing lines inside; smoothed on the wheel; eroded rim; smoked. Another, Rd: 22.00 cm 3/32.

Body sherds, Nile B₂, Marl A₄ c., Marl F.

b) Imported pottery**Cypriote household ware**

No. 6: amphora, VI.TG.40, body sherds: 0.10 dm².

II.- Finds**Suspended weight**

No. 7: net weight (Fig. 4), Inv. No. F0935A (Drawing No. 0943). Limestone. 3.60 x 1.90 x 1.60 cm. Secondary use. Two grooves for fastening, 2 mm wide. *Find No. 025.*

L1408 (Fig. 5)**I.-Pottery**

a) Egyptian pottery**Nile silt clay*****Fine ware******Egyptian painted ware******Black on Red slip ware*****No. 1: jar (Fig. 5:1), Inv. No. P1137A (Drawing No. 0712)**

RSMO	Nile B ₂	W ₂	---	re.	2
------	---------------------	----------------	-----	-----	---

Body sherds (3). Md: ca. 14.00 cm; Wd: 0.50 cm; H₁: 8.00 + x cm. Surface colour: 2.5YR 5/6 red slip. Break: 7.5YR 3/1 very dark grey core; 10R 5/3 weak red oxidation zones. Technical details: made in parts; throwing lines inside. Decoration: horizontally painted bands, 10R 5/1 reddish grey. Surface treatment: smoothed on the wheel.

Egyptian household ware**No. 2: bowl (Fig. 5:1), Inv. No. C-1326 (2) [010]**

Uncoated	Nile B ₂	W ₂
----------	---------------------	----------------

Rim sherd; incurved wall; inverted direct rim. Rd: 20.00 cm 3/32; Wd: 0.70 cm; H₁: 4.50 + x cm; a groove below the rim; smoothed on the wheel.

No. 3: bowl (Fig. 5:1), Inv. No. C-1326 (2) [006]

Uncoated	Nile B ₂	W ₂
----------	---------------------	----------------

Rim sherd; everted direct rim. Rd: 29.00 cm 3/32; Wd: 0.90 cm; H₁: 4.50 + x cm; eroded. Others, Rd: 20.00 cm 1/8, Rd: 24.00 cm 1/32, Rd: 28.00 cm 1/8.

No. 4: bowl (Fig. 5:1), Inv. No. C-1326 (2) [034]

Uncoated	Nile C ₁	W ₂
----------	---------------------	----------------

Rim sherd; everted articulated exterior rim. Rd: 18.00 cm 1/16; Wd: 0.77 cm; H₁: 2.00 + x cm; throwing lines; eroded.

No. 5: bowl (Fig. 5:2), Inv. No. C-1326 (2) [005]

Uncoated	Nile B ₂	W ₂
----------	---------------------	----------------

Rim sherd; carinated walls; everted direct rim. Rd: 28.00 cm 3/32; Wd: 1.00 cm; H₁: 8.00 + x cm; eroded.

No. 6: jar (Fig. 5:2), Inv. No. C-1326 (2) [024]

Uncoated	Nile B ₂	W ₂
----------	---------------------	----------------

Rim sherd; inverted direct rim. Rd: 10.00 cm 1/4; Wd: 0.50 cm; H₁: 2.50 + x cm; throwing lines; eroded. Another, Rd: 10.00 cm 1/4.

No. 7: jar (Fig. 5:2), Inv. No. C-1326 (2) [022]

Uncoated	Nile B ₂	W ₂
----------	---------------------	----------------

Rim sherd; inverted articulated exterior rim, folded lip. Rd: 18.00 cm 3/32; Wd: 0.50 cm; H₁: 3.50 + x cm; throwing lines inside; eroded.

No. 8: jar (Fig. 5:2), Inv. No. C-1326 (2) [026bis]

Uncoated	Nile B ₂	W ₂
----------	---------------------	----------------

Rim sherd; inverted articulated exterior rim. Rd: 14.00 cm 3/32; Wd: 0.60 cm; H₁: 2.50 + x cm; throwing lines; eroded. Another, Rd: 18.00 cm 1/8.

No. 9: jar (Fig. 5:2), Inv. No. C-1326 (2) [020]

Uncoated	Nile B ₂	W ₂
----------	---------------------	----------------

Rim sherd; vertical direct rim. Rd: 10.00 cm 1/4; Wd: 0.50 cm; H₁: 3.50 + x cm; throwing

lines; smoothed on the wheel. Others, Rd: 11.00 cm $\frac{1}{4}$, Rd: 12.00 cm $\frac{5}{32}$, Rd: 14.00 cm $\frac{3}{32}$, 14.00 cm $\frac{5}{32}$.

No. 10: jar?, Inv. No. C-1326 (2) [037]

Uncoated	Nile B ₂	Ha ₂ + W ₂
----------	---------------------	----------------------------------

Handle fragment; attached vertical loop handle. Hd: 3.30 x 2.00 cm; H₁: 14.00 + x cm; smoothed.

No. 11: storage jar (Fig. 5:2), Inv. No. C-1326 (2) [008]

Uncoated	Nile B ₂	W ₂
----------	---------------------	----------------

Rim sherd; inverted direct rim. Rd: 28.00 cm $\frac{1}{8}$; Wd: 1.25 cm; H₁: 10.50 + x cm; throwing lines; eroded.

No. 12: storage jar, Inv. No. C-1326 (2) [043]

Uncoated	Nile B ₂	W ₂
----------	---------------------	----------------

Rim sherd; inverted articulated interior and exterior rim. Rd: 30.00 cm $\frac{3}{4}$; Wd: 0.90 cm; H₁: 7.00 + x cm; throwing lines; smoothed on the wheel.

No. 13: storage jar (Fig. 5:2), Inv. No. C-1326 (2) [013]

Uncoated	Nile B ₂	W ₂
----------	---------------------	----------------

Rim sherd; inverted articulated interior rim. Rd: 38.00 cm $\frac{1}{8}$; Wd: 0.80 cm; H₁: 3.50 + x cm; throwing lines; eroded.

No. 14: storage jar (Fig. 5:2), Inv. No. C-1326 (2) [001]

Uncoated	Nile B ₂	W ₂
----------	---------------------	----------------

Rim sherd; inverted articulated exterior rim, modelled lip. Rd: 26.00 cm $\frac{3}{32}$; Wd: 1.00 cm; H₁: 5.00 + x cm; throwing lines; eroded; smoked. Others, Rd: 24.00 cm $\frac{1}{8}$, Rd: 26.00 cm $\frac{1}{8}$, Rd: 28.00 cm $\frac{1}{8}$, Rd: 28.00 cm $\frac{3}{32}$.

No. 15: storage jar (Fig. 5:3), Inv. No. C-1326 (2) [015]

Uncoated	Nile B ₂	W ₂
----------	---------------------	----------------

Rim sherd; vertical articulated interior and exterior rim, rolled lip. Rd: 20.00 cm $\frac{1}{8}$; Wd: 1.00 cm; H₁: 5.50 + x cm; throwing lines; smoothed on the wheel.

No. 16: storage jar (Fig. 5:3), Inv. No. P1172A (Drawing No. 0936)

Uncoated	Nile C ₁	W ₂	---	ox.	2
----------	---------------------	----------------	-----	-----	---

Rim and body fragment; convex side walls; articulated exterior lip; [2 handles]. Rd: 27.00 cm $\frac{7}{32}$; Md: 29.00 cm; Wd: 1.10 cm; H₁: 21.00 + x cm; H₂: 6.00 + x cm. Surface colour: 2.5YR 5/3 reddish brown. Break: 5YR 4/1 dark grey core; 2.5YR 5/3 reddish brown oxidation zones. Technical details: made in parts. Surface treatment: smoothed on the wheel.

Votive ware

No. 17: votive pot? (Fig. 5:3), Inv. No. C-1326 (2) [011]

RS	Nile B ₂	W ₂
----	---------------------	----------------

Rim and body fragment; incurved walls; everted direct rim. Rd: 6.00 cm $\frac{1}{4}$; Wd: 0.35 cm; H₁: 3.50 + x cm; red slip; smoothed on the wheel.

Pottery with special functions

No. 18: lid (Fig. 5:3), Inv. No. C-1326 (2) [012]

Uncoated	Nile B ₂	W ₂
----------	---------------------	----------------

Rim sherd; everted direct rim. Rd: 28.00 cm 3/32; Wd: 0.60 cm; H₁: 1.70 + x cm; throwing lines; eroded. Another, Rd: 20.00 cm 1/32.

No. 19: spinning bowl, Inv. No. C-1326 (2) [036]

Uncoated	Nile B ₂	W ₂
----------	---------------------	----------------

Body fragment.

Egyptian marls

Household ware

No. 20: jar, Inv. No. C-1326 (2) [038bis]

Uncoated	Marl F v. s.	Ha ₂
----------	--------------	-----------------

Handle fragment; attached vertical loop handle. Hd: 2.50 x 2.10 cm; smoothed.

b) Imported pottery

Levantine household ware

No. 21: amphora, IV.TG 24, body sherds, 0.10 dm².

No. 22: amphora, IV.TG 51(= TD IV.19), body sherds, 0.10 dm².

No. 23: amphora, IV.TG 52(= TD IV.19 coarse), body sherds, 0.10 dm².

No. 24: amphora, IV.TG 53 (= TD IV.09), handle fragment, Hd: 2.80 x 1.70 cm; body sherds, 0.10 dm².

No. 25: amphora, = TD IV.08, body sherds, 0.10 dm².

No. 26: amphora, = TD IV.10, body sherds, 0.10 dm².

Cypriote household ware

No. 27: amphora, VI.TG 40, body sherds, 0.10 dm².

No. 28: amphora, VI.TG 42, body sherds, 0.10 dm².

II.-Finds

Weapon?

No. 29: fragment of an object, Inv. No. F0732A (Drawing No. 0618). Iron; melted. 4.00 x 0.70 x 0.50 cm. *Find No. 007.*

Object of unknown use

No. 30: fragment of an object, Inv. No. F0722A. Bronze. 1.00 x 2.50 cm. *Find No. 012.*

L1409 (Fig. 6)

I.- Pottery

a) Egyptian pottery

Nile silt clay

Household ware

No. 1: bowl (Fig. 6:1), Inv. No. C-1308 [005]

Uncoated	Nile B ₂	W ₂
----------	---------------------	----------------

Rim sherd; inverted articulated interior and exterior rim. Rd: 20.00 cm 3/32; Wd: 0.65 cm; H₁: 3.00 + x cm; a groove below the rim; smoothed on the wheel.

No. 2: bowl (Fig. 6:1), Inv. No. C-1308 [010]

Uncoated	Nile B ₂	W ₂
----------	---------------------	----------------

Rim sherd; everted direct rim. Rd: 20.00 cm ¼; Wd: 0.50 cm; H₁: 1.50 + x cm; smoothed on the wheel. Others, Rd: 22.00 cm 1/32; Rd: 22.00 cm 1/32. Nile C₁, Rd: 24.00 cm 3/32.

No. 3: bowl (Fig. 6:1), Inv. No. C-1308 (2) [003]Uncoated | Nile B₂ | W₂

Rim and wall fragment; incurved wall; everted articulated exterior rim, modelled lip. Rd: 24.00 cm 1/16; Wd: 0.90 cm; H₁: 6.45 + x cm; smoked inside (used as a cover?).

No. 4: bowl (Fig. 6:1), Inv. No. C-1308 (2) [001]Uncoated | Nile B₂ | W₂

Rim fragment; everted articulated exterior rim, round lip. Rd: 26.00 cm 1/16; Wd: 0.80 cm; H₁: 3.40 + x cm; eroded.

No. 5: [globular] jar, Inv. No. C-1308 [007]Uncoated | Nile B₂ | W₂

Rim sherd; vertical direct rim. Rd: 9.00 cm 1/4; Wd: 0.50 cm; H₁: 4.00 + x cm; throwing lines inside; smoothed on the wheel.

No. 6: jar (Fig. 6:1), Inv. No. C-1308 [015]Uncoated | Nile B₂ | W₂

Rim sherd; inverted direct rim. Rd: 9.00 cm 3/32; Wd: 0.70 cm; H₁: 7.00 + x cm; throwing lines inside; a groove below the rim; smoothed on the wheel. Another, Nile B₂ v. s., Rd: 12.00 cm 3/16.

No. 7: jar (Fig. 6:1), Inv. No. C-1308 [006]Uncoated | Nile B₂ | W₂

Rim sherd; inverted articulated interior rim. Rd: 10.00 cm 5/32; Wd: 0.50 cm; H₁: 3.80 + x cm; throwing lines inside; smoothed on the wheel.

No. 8: jar?, Inv. No. C-1308 [008]Uncoated | Nile B₂ | W₂

Rim sherd; inverted articulated interior and exterior rim. Rd: 18.00 cm 1/8; Wd: 0.40 cm; H₁: 2.50 + x cm; throwing lines inside; smoothed on the wheel.

No. 9: jar (Fig. 6:1), Inv. No. C-1308 (2) [002]Uncoated | Nile B₂ | W₂

Rim fragment; inverted articulated interior and exterior rim, rolled lip. Rd: 18.00 cm 7/32; Wd: 0.90 cm; H₁: 8.70 + x cm; throwing lines inside; eroded inside and outside.

No. 10: jar (Fig. 6:1), Inv. No. C-1308 [019]Uncoated | Nile B₂ | W₂

Rim sherd; vertical direct rim. Rd: 14.00 cm; Wd: 0.60 cm; H₁: 3.00 + x cm; throwing lines inside; smoothed on the wheel.

No. 11: jar (Fig. 6:1), Inv. No. C-1308 [003]Uncoated | Nile B₂ | W₂

Rim sherd; everted direct rim. Rd: 14.00 cm 3/16; Wd: 1.00 cm; H₁: 3.50 + x cm; throwing lines inside; smoothed on the wheel.

No. 12: jar, Inv. No. C-1308 [004]Uncoated | Nile B₂ | W₂ + Ha₂

Body fragment and swelling of a handle; Wd: 0.50 cm; throwing lines outside; eroded.

No. 13: jar, Inv. No. C-1308 (2) [007]

Uncoated	Nile B ₂	Ha ₂ + W ₂
----------	---------------------	----------------------------------

Handle fragment; attached to body vertical loop handle. Hd: 3.30 x 2.10 cm; Wd: 1.20 cm; H₁: 7.00 + x cm; eroded. Another, Hd: 3.40 x 2.20 cm

No. 14: storage jar (Fig. 6:1), Inv. No. C-1308 [004]

Uncoated	Nile B ₂	W ₂
----------	---------------------	----------------

Rim sherd; inverted articulated interior and exterior rim. Rd: 28.00 cm 3/32; Wd: 0.80 cm; H₁: 4.00 + x cm; throwing lines inside; smoothed on the wheel.

No. 15: storage jar (Fig. 6:2), Inv. No. C-1308 [002]

Uncoated	Nile B ₂	W ₂
----------	---------------------	----------------

Rim sherd; inverted articulated interior rim. Rd: 28.00 cm 3/32; Wd: 1.00 cm; H₁: 6.00 + x cm; throwing lines inside; smoothed on the wheel.

No. 16: storage jar (Fig. 6:2), Inv. No. C-1308 [001]

Uncoated	Nile B ₂	W ₂
----------	---------------------	----------------

Rim sherd; everted articulated interior and exterior rim. Rd: 20.00 cm 5/32; Wd: 1.00 cm; H₁: 4.00 + x cm; throwing lines inside; smoothed on the wheel.

Pottery with special functions

No. 17: lid (Fig. 6:2), Inv. No. C-1308 (2) [005]

Uncoated	Nile C ₁	W ₂
----------	---------------------	----------------

Rim sherd; everted direct rim. Rd: 22.00 cm 5/32; Wd: 0.70 cm; H₁: 1.60 + x cm; throwing lines inside; smoothed on the wheel; smoked. Another, Rd: 30.00 cm 1/16.

No. 18: bakery tray, Inv. No. C-1308 [002bis]

Uncoated	Nile C ₁	W ₁
----------	---------------------	----------------

Rim fragment; everted direct rim. Rd: 24.00 cm 3/32; eroded.

Body sherds, Nile B₂: 90.00 dm²; Nile C₁: 2.00 dm²; Nile C₂ c.: 3.00 dm².

b) North Sinai/South Palestine pottery

Household ware

No. 19: amphora, II.TG 10, body sherds, 0.10 dm².

c) Imported pottery

Levantine household ware

No. 20: amphora, IV.TG 51(= TD IV.19), body sherds, 0.10 dm².

No. 21: amphora, IV.TG 52(= TD IV.19 c.), body sherds, 0.50 dm².

No. 22: amphora, IV.TG 53 (= TD IV.09), body sherds, 0.10 dm².

Cypriote household ware

No. 23: amphora, VI.TG 49, body sherds, 0.10 dm².

II.- Finds

Personal objects

No. 24: bead (Fig. 6:2), Inv. No. F0707A (Drawing No. 0459). Complete; faience; moulded. 0.64 x 0.24 cm; colour: 5Y 7/1 light grey- 6/1 grey. Cylindrical shape; perforation: 2.6 mm. *Find No. 013*.

Objects of unknown use

No. 25: fragment of an object, Inv.No. F0648A. Wood; carved. 0.84 x 0.96 x 0.51 cm. Colour: 7.5YR 6/6 reddish yellow. Shape: nearly cubic. *Find No. 006.*

No. 26: fragment of an object, Inv. No. F0907A (before Inv. No. F0907B. Drawing No. 1083). Gypsum; 1.20 cm; colour: white; part of a mould? *Find No. 014.*

L1410 (Fig. 7)**I.- Pottery****Egyptian pottery****Nile silt clay****Fine ware****Egyptian painted ware****Black on Red slip ware**

No. 1: jar (Fig. 7:1), Inv. No. P7017A (Drawing No. 0905)

RPMO	Nile B ₂	W ₂	---	re.	2-3
------	---------------------	----------------	-----	-----	-----

Body sherd. Md: 17.00 + x cm; Wd: 0.35 cm; H₁: 4.50 + x cm. Surface colour: 10R 5/4 weak red slip. Break: 2.5YR 2.5/1 reddish black. Decoration: two horizontally painted bands, 3 mm wide, 10R 4/1 dark reddish grey. Surface treatment: polished, medium lustre.

Household ware

No. 2: bowl (Fig. 7:1), Inv. No. C-1329 (2) [005]

Uncoated	Nile B ₂	W ₂
----------	---------------------	----------------

Rim sherd; incurved wall, inverted direct rim. Rd: 20.00 cm 3/32; Wd: 0.90 cm; H₁: 5.40 + x cm; smoothed on the wheel; smoked inside and on the rim (used as a cover). Others, Nile C₁, Rd: 20.00 cm 1/16, Rd: 24.00 cm 3/32.

No. 3: bowl (Fig. 7:1), Inv. No. C-1329 (2) [001]

Uncoated	Nile C ₁	W ₂
----------	---------------------	----------------

Rim sherd; incurved wall, everted direct rim. Rd: 24.00 cm 1/16; Wd: 0.80 cm; H₁: 4.00 + x cm; smoothed on the wheel. Others, Rd: 18.00 cm 3/32, Nile B₂, Rd: 23.00 cm 7/64, Rd: 24.00 cm 3/32.

No. 4: deep bowl (Fig. 7:1), Inv. No. P7028A (Drawing No. 0907)

Uncoated	Nile B ₂	W ₂	base finished on the wheel	ox.	2
----------	---------------------	----------------	----------------------------	-----	---

Complete (reconstructed shape), fragmentary; pointed base 1/1. Rd: 11.00 cm 1/8; Wd: 0.35 cm; H₁: 13.10 cm. VI: 84. Surface colour: 5YR 6/3 light reddish brown. Break: 2.5YR 5/6 red. Technical details: ridges below the rim and on the base, outside. Surface treatment: smoothed on the wheel.

No. 5: goblet (Fig. 7:1), Inv. No. C-1329 (2) [028]

Uncoated	Nile B ₂	W ₂
----------	---------------------	----------------

Foot and body fragment. Fd: ca. 2.50 + x cm; Wd: 0.55 cm; H₁: 4.00 + x cm; H₄: 2.00 + x cm. Throwing lines inside; smoothed on the wheel; eroded.

No. 6: cup (Fig. 7:1), Inv. No. C-1329 (2) [026]

Uncoated	Nile B ₂	W ₂
----------	---------------------	----------------

Rim sherd; inverted direct rim. Rd: 6.00 cm 3/32; Wd: 0.40 cm; H₁: 3.00 + x cm. Throwing lines inside; smoothed on the wheel; eroded.

No. 7: juglet, Inv. No. C-1329 (2) [034]

Uncoated	Nile B ₂	Ha ₂
----------	---------------------	-----------------

Handle fragment; attached loop handle. Hd: 1.50 x 0.90 cm; eroded.

No. 8: jar (Fig. 7:2), Inv. No. C-1329 (2) [006]

Uncoated	Nile B ₂	W ₂
----------	---------------------	----------------

Rim sherd; inverted direct rim, folded lip. Rd: 10.00 cm 1/4; Wd: 0.50 cm; H₁: 5.40 + x cm. Throwing lines inside; smoothed on the wheel. Others, Rd: 6.00 cm 1/4, Rd: 10.00 cm 5/32, Rd: 10.00 cm 1/8, Rd: 12.00 cm 3/16, Rd: 8.00 cm 5/32.

No. 9: jar (Fig. 7:2), Inv. No. C-1329 (2) [011]

Uncoated	Nile B ₂	W ₂
----------	---------------------	----------------

Rim sherd; inverted articulated interior and exterior rim, modelled lip. Rd: 18.00 cm 3/16; Wd: 0.80 cm; H₁: 7.90 + x cm. Throwing lines inside; smoothed on the wheel; eroded. Another, Rd: 18.00 cm 1/4.

No. 10: jar (Fig. 7:2), Inv. No. C-1329 [004]

Uncoated	Nile B ₂	W ₂
----------	---------------------	----------------

Rim sherd; vertical direct rim. Rd: 10.00 cm 3/16; Wd: 0.50 cm; H₁: 4.50 + x cm. Throwing lines inside; smoothed on the wheel.

No. 11: jar (Fig. 7:2), Inv. No. P7038A (Drawing No. 0910)

RPMO	Nile B ₂	W ₂	---	re.	2-3
------	---------------------	----------------	-----	-----	-----

Body sherd. Md: ca. 20.00 + x cm; Wd: 0.50 cm; H₁: 8.20 + x cm. Surface colour: 10R 5/6 red slip. Break: 10R 4/1 dark reddish grey. Technical details: made in parts; ridges inside. Decoration: three horizontally painted bands, 3 mm wide, 10R 4/1 dark reddish grey. Surface treatment: polished, medium lustre.

No. 12: jar, Inv. No. C-1329 (2) [029]

Uncoated	Nile B ₂	W ₂	W
----------	---------------------	----------------	---

Base fragment; round base. Wd: 1.10 cm; H₁: 9.30 + x cm. Throwing lines inside; smoothed on the wheel; eroded. Others, 2 bases.

No. 13: storage jar (Fig. 7:2), Inv. No. C-1329 [002]

Uncoated	Nile B ₂	W ₂
----------	---------------------	----------------

Rim sherd; inverted direct rim, folded lip. Rd: 30.00 cm 5/64; Wd: 1.00 cm; H₁: 4.80 + x cm. Throwing lines inside; smoothed on the wheel.

No. 14: storage jar (Fig. 7:2), Inv. No. C-1329 (2) [020]

Uncoated	Nile B ₂	W ₂
----------	---------------------	----------------

Rim sherd; inverted articulated interior rim, modelled lip. Rd: 28.00 cm 3/16; Wd: 0.80 cm; H₁: 4.30 + x cm. Throwing lines inside; smoothed on the wheel; eroded. Another, Rd: 18.00 cm 3/16.

No. 15: storage jar (Fig. 7:2), Inv. No. C-1329 [003]

Uncoated	Nile B ₂	W ₂
----------	---------------------	----------------

Rim sherd; inverted articulated exterior rim, round lip. Rd: 24.00 cm 3/32; Wd: 0.60 cm; H₁: 3.70 + x cm. Throwing lines inside; smoothed on the wheel.

No. 16: storage jar (Fig. 7:2), Inv. No. C-1329 (2) [013]

Uncoated	Nile C ₁	W ₂
----------	---------------------	----------------

Rim sherd; inverted articulated interior and exterior rim, round lip. Rd: 22.00 cm 3/32;

Wd: 0.85 cm; H_1 : 5.80 + x cm. Throwing lines inside; smoothed on the wheel; eroded. Another, Rd: 22.00 cm 1/8.

No. 17: storage jar (Fig. 7:3), Inv. No. C-1329 (2) [009]

Coated Nile B₂ W₂

Rim sherd; everted articulated interior and exterior rim, modelled lip. Rd: 20.00 cm 5/32; Wd: 0.80 cm; H_1 : 8.80 + x cm. Throwing lines inside; slip: 5YR 7/4 pink; smoothed on the wheel. Another, Rd: 21.00 cm 3/32.

No. 18: storage jar, Inv. No. C-1329 (2) [031]

Uncoated Nile B₂ Ha₂ + W₂

Handle fragment; attached loop handle; Hd: 2.30 x 2.10 cm; eroded. Others, Hd: 3.10 x 1.90 cm; Hd: 2.10 x 0.90 cm; Hd: 3.10 x 2.35 cm.

No. 19: amphora, Inv. No. C-1329 (2) [030]

Uncoated Nile B₂ Ha₂ + W₂

Handle fragment; attached body to body vertical loop handle. Wd: 0.60 cm; H_1 : 12.00 + x cm; Hd: 3.10 x 1.80 cm. Throwing lines inside; smoothed; eroded.

Pottery with special functions

No. 20: lid (Fig. 7:3), Inv. No. C-1329 (2) [016]

Uncoated Nile B₂ W₂

Rim sherd; everted direct rim. Rd: 24.00 cm 3/32; Wd: 0.80 cm; H_1 : 5.50 + x cm. Throwing lines inside; smoothed on the wheel; eroded; smoked inside. Others, Rd: 24.00 cm 1/8, Rd: 26.00 cm 1/32.

No. 21: bakery tray (Fig. 7:3), Inv. No. C-1329 [001]

Uncoated Nile C₂ W₁

Rim fragment; everted direct rim. Rd: 25.00 cm 3/16; Wd: 1.70 cm; H_1 : 4.70 + x cm. Throwing lines inside; smoothed on the wheel.

Egyptian marls

Household ware

No. 22: jar, Inv. No. C-1329 [006]

Uncoated Marl F Ha₂

Handle fragment; attached from upper body to rim vertical loop handle; Hd: 3.30 x 1.80 cm; eroded.

Body sherds, Nile B₂: 70.00 dm²; Nile C₁: 2.00 dm²; Nile C₂ c.: 2.00 dm²; Marl A₄; Marl F.

b) Imported pottery

Levantine household ware

No. 23: handle fragment, Inv. No. C-1329, IV.TG 07, body sherds: 0.10 dm².

No. 24: handle fragment, Inv. No. C-1329, IV.TG 18.

No. 25: amphora, Inv. No. C-1329 (2) [019]

Uncoated IV.TG 18 W₂

Rim sherd; vertical direct rim. Rd: 14.00 cm 1/8; Wd: 0.90 cm; H_1 : 4.50 + x cm. Throwing lines inside; smoothed on the wheel; eroded.

No. 26: handle fragment, Inv. No. C-1329, IV.TG 51 (= TD IV.19), body sherds: 0.10 dm².

II.- Finds

Religion

No. 27: scarab (Fig. 7:3), Inv. No. F0640A (Drawing No. 0453; object sketch). Complete; faience; moulded. 0.90 cm x 1.20 cm x 0.70 cm. Colour: 10YR 7/2 light grey. Description: carved on both sides, the base is decorated with a volutes motive, illegible; longitudinal perforation. Observations: broken in two pieces and mended. *Find No. 020*.

Personal object

No. 28: bead, Inv. No. F0830A (Drawing No. 0930). Complete; shell (*Ciprea albina*). 1.30 x 0.50 x 1.80 cm. Function: female fertility amulet.

Stone vessel

No. 29: bowl (Fig. 7:3), Inv. No. F1083A (before F0920B. Drawing No. 0919). Rim fragment. Rd: 18.00 cm.

Tool

No. 30: pumice fragment, Inv. No. F0937A. 5.00 x 4.00 x 3.50 cm. *Find No. 017*.

Object of unknown use

No. 31: fragment of an object, Inv. No. F0742A. Bronze. 0.90 x 0.60 cm. *Find No. 021*.

Product

No. 32: slag, Inv. No. F0854A. *Find No. 011*.

L1413 (Fig. 8)

Egyptian pottery

Nile silt clay

Household ware

No. 1: goblet (Fig. 8), Inv. No. P1124A (Drawing No. 0521)

Uncoated	Nile B ₂	W ₂	W	ox.	2
----------	---------------------	----------------	---	-----	---

Foot fragment. Fd: 4.00 cm 1/1; H₁: 3.35 + x cm; H₄: 3.00 cm. Surface colour: 2.5YR 6/6 light red. Break: 2.5YR 4/1 reddish grey core; 2.5YR 6/6 light red oxidation zones. Surface treatment: smoothed on the wheel. *Find No. 004*.

L1419 (Fig. 9)

I.- Egyptian pottery

Nile silt clay

Household ware

No. 1: deep bowl (Fig. 9), Inv. No. P1235A (Drawing No. 0517)

Uncoated	Nile B ₂	W ₂	W	ox.	2
----------	---------------------	----------------	---	-----	---

Base fragment; pointed base (flattened). Md: 9.00 + x cm; Wd: 0.50 cm; H₁: 7.00 + x cm. Surface colour: 2.5YR 4/4 reddish brown. Break: 5YR 5/3 reddish brown. Technical details: sharp throwing lines outside, throwing lines inside. Surface treatment: smoothed on the wheel.

No. 2: storage jar (Fig. 9), Inv. No. C-1325 (2) [001]

Uncoated	Nile B ₂	W ₂
----------	---------------------	----------------

Rim sherd; inverted direct rim. Rd: 30.00 cm 3/32; Wd: 0.50 cm; H₁: 3.50 + x cm; throwing lines inside; smoothed on the wheel. *Find No. 5.*

II.-Finds

Personal object

No. 3: bead (Fig. 9) Inv. No. F0677A (Drawing No. 0462). Complete; faience; moulded. 0.60 x 0.20 cm; colour: 7.5YR 8/1 white; cylindrical shape; perforation: 2.4 mm. *Find No. 025.*

L1420 (Fig. 10)

I.- Pottery

Egyptian pottery

Nile silt clay

Fine ware

Egyptian painted ware

Black on Red slip ware

No. 1: jar (Fig. 10:1), Inv. No. P1139A (Drawing No. 0933)

RPMO	Nile B ₂	W ₂	---	re.	2-3
------	---------------------	----------------	-----	-----	-----

Body sherd. Md: 14.00 + x cm; Wd: 0.35 cm; H₁: 2.30 + x cm. Surface colour: 10R 5/6 red slip. Break: 2.5YR 4/6 red exterior; 4/1 dark reddish grey interior. Technical details: made in parts; throwing lines inside. Decoration: three horizontally painted bands, 2 mm wide, 10R 3/1 dark reddish grey. Surface treatment: polished, medium lustre.

Household ware

No. 2: bowl (Fig. 10:1), Inv. No. C-1313 [006]

Uncoated	Nile B ₂	W ₂
----------	---------------------	----------------

Rim sherd; inverted direct rim. Rd: 24.00 cm 3/64; Wd: 0.75 cm; H₁: 2.50 + x cm; smoothed on the wheel. Another, Rd: 17.00 cm 3/64.

No. 3: bowl (Fig. 10:1), Inv. No. C-1313 [008]

Uncoated	Nile B ₂	W ₂
----------	---------------------	----------------

Rim sherd; incurved walls, inverted direct rim, trimmed. Rd: 19.00 cm 3/16; Wd: 0.60 cm; H₁: 2.80 + x cm; smoothed on the wheel.

No. 4: bowl (Fig. 10:1), Inv. No. C-1313 (2) [009]

Uncoated	Nile B ₂	W ₂
----------	---------------------	----------------

Rim sherd; inverted articulated exterior rim, round lip. Rd: 18.00 cm 3/32; Wd: 0.70 cm; H₁: 3.60 + x cm. Throwing lines inside; smoothed on the wheel; eroded. Another, Rd: 18.00 cm 7/32

No. 5: bowl (Fig. 10:1), Inv. No. C-1313 [005]

RS	Nile B ₂	W ₂
----	---------------------	----------------

Rim sherd; everted direct rim. Rd: 24.00 cm 1/8; Wd: 0.90 cm; H₁: 5.20 + x cm; red slipped; smoothed on the wheel. Another, uncoated, Rd: 22.00 cm 3/32, smoked (used as a lid).

No. 6: bowl (Fig. 10:1), Inv. No. C-1313 [007]

Uncoated	Nile B ₂ s.	W ₂
----------	------------------------	----------------

Rim sherd; everted articulated exterior rim, modelled lip. Rd: 22.00 cm 3/32; Wd: 0.70 cm;

H₁: 3.90 + x cm. Throwing lines inside; smoothed on the wheel.

No. 7: bowl (Fig. 10:1), Inv. No. C-1313 [021]

Uncoated Nile C₁ Ha₁

Rim sherd; everted direct rim, flat. Rd: 40.00 cm 3/64; Wd: 2.00cm; H₁: 6.70 + x cm; smoothed; string marks outside.

No. 8: shallow bowl (Fig. 10:1), Inv. No. C-1313 [003]

Uncoated Nile B₂ W₂

Rim sherd; convex sided walls, vertical direct rim, flattened. Rd: 24.00 cm 1/8; Wd: 0.70 cm; H₁: 5.00 + x cm. Throwing lines inside; smoothed on the wheel.

No. 9: deep bowl, Inv. No. C-1313 [025]

Uncoated Nile B₂ W₂ W

Base fragment; round base. Wd: 0.50cm; H₁: 2.10 + x cm; smoothed on the wheel.

No. 10: cup, Inv. No. C-1313 [027]

Uncoated Nile B₂ W₂ base finished on the wheel

Base fragment; pointed base. Wd: 0.35cm; H₁: 1.50 + x cm. Throwing lines inside and outside; smoothed on the wheel. Another, 1 base.

No. 11: juglet, Inv. No. C-1313 [031]

Uncoated Nile B₂ Ha₂

Handle fragment; loop handle; Hd: 1.00 x 0.90 cm; smoothed.

No. 12: jar (Fig. 10:1), Inv. No. C-1313 (2) [007]

Uncoated Nile B₂ W₂

Rim sherd; flaring walls, inverted direct rim. Rd: 10.00 cm 5/32; Wd: 0.60 cm; H₁: 5.10 + x cm. Throwing lines inside; smoothed on the wheel; eroded. Another, Rd: 13.00 cm 3/64.

No. 13: jar (Fig. 10:2), Inv. No. C-1313 (2) [005]

Uncoated Nile B₂ W₂

Rim sherd; flaring walls, inverted articulated exterior rim, modelled lip. Rd: 18.00 cm 3/32; Wd: 1.00 cm; H₁: 11.60 + x cm. Throwing lines inside; smoothed on the wheel; eroded.

No. 14: jar (Fig. 10:2), Inv. No. C-1313 [001]

RS Nile B₂ W₂

Rim sherd; inverted articulated interior and exterior rim, modelled lip. Rd: 17.00 cm 1/8; Wd: 0.90 cm; H₁: 4.20 + x cm. Throwing lines inside; red slipped; smoothed on the wheel.

No. 15: jar (Fig. 10:2), Inv. No. C-1313 [015]

Uncoated Nile B₂ W₂

Rim sherd; vertical direct rim, folded lip. Rd: 11.00 cm 5/32; Wd: 0.60cm; H₁: 5.60 + x cm. Throwing lines inside; smoothed on the wheel. Others, Rd: 8.00 cm 1/8, Rd: 8.00 cm 1/8, Rd: 8.00 cm 3/32, Rd: 10.00 cm 3/8, Rd: 10.00 cm 1/16, Rd: 10.50 cm 3/64, Rd: 11.00 cm 3/64, Rd: 11.00 cm 1/8.

No. 16: jar, Inv. No. C-1313 (2) [010]

Uncoated Nile B₂ W₂

Rim sherd; everted articulated interior and exterior rim, trimmed lip. Rd: 16.00 cm 7/32.

Throwing lines inside; smoothed on the wheel; very eroded.

No. 17: jar, Inv. No. C-1313 [023]

Uncoated	Nile C ₁	W ₂	W
----------	---------------------	----------------	---

Base fragment; round base; Wd: 0.70cm; H₁: 3.70 + x cm. Throwing lines inside; smoothed on the wheel; smoked outside. Another, 1 base.

No. 18: jar, Inv. No. C-1313 [030]

Uncoated	Nile B ₂	Ha ₂
----------	---------------------	-----------------

Handle fragment; loop handle; Hd: 4.30 x 2.50 cm. Another, Hd: 2.90 x 2.20 cm.

No. 19: storage jar (Fig. 10:2), Inv. No. C-1313 (2) [001]

Uncoated	Nile B ₂	W ₂
----------	---------------------	----------------

Rim sherd; straight sided walls, inverted articulated exterior rim, round lip. Rd: 22.00 cm 3/32; Wd: 0.90 cm; H₁: 10.00 + x cm. Throwing lines inside; smoothed on the wheel; eroded on the rim. Another: Rd: 30.00 cm 1/8.

No. 20: storage jar (Fig. 10:2), Inv. No. C-1313 (2) [002]

Uncoated	Nile B ₂	W ₂
----------	---------------------	----------------

Rim sherd; inverted articulated interior and exterior rim, trimmed lip. Rd: 22.00 cm 3/32; Wd: 0.75 cm; H₁: 6.60 + x cm. Throwing lines inside; smoothed on the wheel; eroded on the rim.

No. 21: storage jar (Fig. 10:2), Inv. No. C-1313 (2) [004]

Uncoated	Nile B ₂	W ₂
----------	---------------------	----------------

Rim sherd; inverted articulated interior and exterior rim, modelled lip. Rd: 30.00 cm 1/8; Wd: 0.85 cm; H₁: 4.50 + x cm. Throwing lines inside; smoothed on the wheel; eroded. Another: Rd: 20.00 cm 1/16.

No. 22: storage jar, Inv. No. C-1313 [029]

Uncoated	Nile B ₂	Ha ₂
----------	---------------------	-----------------

Handle fragment; attached vertical loop handle; Hd: 3.40 x 2.10 cm.

No. 23: storage jar, Inv. No. C-1313 (2)

Uncoated	Nile B ₂	W ₂
----------	---------------------	----------------

Body fragment; Md: 30.00 cm; throwing lines inside; smoked inside.

Pottery with special functions

No. 24: lid (Fig. 10:2), Inv. No. C-1313 (2) [008]

Uncoated	Nile B ₂	W ₂
----------	---------------------	----------------

Rim sherd; everted direct rim. Rd: 26.00 cm 3/32; Wd: 0.75 cm; H₁: 3.50 + x cm. Throwing lines inside; smoothed on the wheel; smoked inside; eroded.

No. 25: bakery tray (Fig. 10:3), Inv. No. C-1313 (2) [012]

Uncoated	Nile C ₂	W ₁	H
----------	---------------------	----------------	---

Rim and base fragment; pinched base, everted direct rim. Rd: 22.00 cm 5/32; Bd: 20.00 cm; Wd: 1.45 cm; H₁: 5.60 cm; VI: 393. Eroded. Another (only rim), Nile C₁, Rd: 31.00 cm 3/32.

Votive pottery

No. 26: model bowl? (Fig. 10:3), Inv. No. C-1313 [009]

Uncoated	Nile B ₂	W ₂
----------	---------------------	----------------

Rim sherd; carinated walls, everted direct rim. Rd: 14.00 cm 1/32; Wd: 0.40 cm; H₁: 2.50 + x cm. Throwing lines inside; smoothed on the wheel.

Egyptian marls

Household ware

No. 27: jar (Fig. 10:3), Inv. No. P1167A (Drawing No. 0638)

Uncoated	Marl A ₄	W ₂	---	ox.	3
----------	---------------------	----------------	-----	-----	---

Body fragment; [round base]. Md: 16.00 cm; Wd: 0.50 cm; H₁: 6.00 + x cm. Surface colour: self slip, 2.5YR 6/6 light red inside and 2.5Y 7/2 light grey outside. Break: 2.5YR 6/6 interior; 2.5YR 7/2 pale red exterior. Technical details: throwing lines inside. Surface treatment: smoothed on the wheel.

No. 28: jar, Inv. No. C-1313 (2) [015]

Uncoated	Marl F	W ₂
----------	--------	----------------

Handle fragment; loop handle; Hd: 3.10 x 2.35 cm; smoothed.

Body sherds, Nile B₂, Nile B₂/C₁, Marl A₄ c., Marl F.

b) Imported pottery

Levantine household ware

No. 29 amphora, IV.TG 52 (= TD IV.19 c.), body sherds: 0.10 dm².

No. 30 amphora, IV.TG 53 (= TD IV.09), body sherds: 0.10 dm².

No. 31 amphora, Inv. No. C-1313 (2) [014], handle fragment, IV.TG 53 (= TD IV.09), Hd: 3.90 x 2.10 cm.

Cypriote household ware

No. 32: amphora, VI.TG 40, body sherds: 0.10 dm².

II.- Finds

Recreation

No. 33: gaming piece (Fig. 10:3), Inv. No. F0684 (Drawing No. 0451). Fragmentary; faience; moulded. 1.21 x 1.49 x 1.07 cm; colour: 5Y 8/1 (white); mushroom shape (a piece of Senet); the base is broken. SCA No. 4010. *Find No. 030.*

Personal objects

No. 34: bead (Fig. 10:3), Inv. No. F0637A (Drawing No. 0463). Complete; faience; moulded. D: 0.46 cm; colour: 2.5Y 7/2 light grey. Cylindrical shape; perforation: 2.4 mm. *Find No. 027.*

No. 35: bead (Fig. 10:3), Inv. No. F0639A (Drawing No. 0455). Fragmentary (1/2); carnelian. 1.39 x 0.36 cm; colour: 10R 4/6 red. Cylindrical shape; perforation: 6.6 mm. *Find No. 025.*

Objects of unknown use

No. 36: fragment of an object, Inv. No. F0718A. Bronze. 0.90 x 0.60 cm. *Find No. 029.*

No. 37: fragments (6) of an object (a needle?), Inv. No. F0731A. Bronze; melted. 6.00 x 2.00 cm. *Find No. 032.*

No. 38: fragment of an object, Inv. No. F0748A. Faience. 1.85 x 1.10 x 0.53 cm; colour: Chart 1 for gley between 8/5 GY and 8/10 GY (light greenish grey). Two incised lines; the observe is flat. *Find No. 031.*

LEVEL II: Building L

Since the series of walls we are calling here Building L (Plan VI; Plates X and XI) are overlain by the rather thick walls of Building D, we cannot be sure whether the former is one and the same structure or two different buildings. Considering the orientation of the rooms and the coherent depth of the occupational surfaces, we prefer the first possibility and will adopt it in the description that follows. Nevertheless, a massive and extended stratum of clean sand (L1412; Plate X) under rooms L-1 and L-2, interpreted as a possible foundation layer, did not show under rooms L-4 and L-5, and the successive refurbishments noted in rooms L-1 and L-2 did not take place in rooms L-4 and L-5, so the alternative of two adjacent buildings can not be ruled out.

Building L was built of mud bricks. Sometimes, courses of headers and stretchers alternate, while other times, the layout follows a random pattern.

Walls of Building L

- L1403. This wall forms the northern side of Room L-2. Its foundation is 1.04 m wide and has six alternating courses of headers and stretchers with a socle of protruding headers, some of them disposed obliquely. The remains of its upper part consist of only one course of badly damaged mud bricks. The mud bricks were rich in clay and are 31 - 38 cm long, 18.7 - 23.1 cm wide and 6.2 - 9 cm thick, with some outliers. Two successive door sockets rested on L1403 and will be referred to along with the floors to which they link.
- **L1107**. This wall is the north-western limit of rooms L-1 and L-2. Mud bricks are 30 to 43 cm long (mean about 34 cm), 17 to 19 cm wide and 9 cm thick. The seven to ten courses left (the lowest being a socle of protruding headers) seem to belong to the foundation (Plate X).
- A short and partially hollow wall (L1129) separates rooms L-1 and L-2. It is massive in its bonding to L1007 but is continued by two narrow mud brick projections (its external sides) and one course of obliquely disposed mud bricks (for the base). The proximity of an intrusive pit and the walls of overlying Building D add difficulty to the interpretation of this T-shaped arrangement, which may have been devised to place a ladder.
- L1428. This wall limits Room L-2 by the southeast. Seven courses are left. Mud brick sizes are similar to L1403. It served as a basis for wall L1051 of the superposed Building D.
- L1121. Only a small part of this wall was unearthed, since it is covered by walls L1051 and L1082 of Building D. Again, only the foundation seems to have been left, and its northern portion was cut in antiquity by the pit just referred to. At least six courses have been preserved. Mud brick dimensions are: length 29 to 38 cm, width 17 to 19 cm and thickness 9 cm. This wall was no longer functional during the last stage of use of Building L (see below), since it had been sealed by occupational surface **L1108**.
- L1232 forms the south-western side of rooms L-4 and L-5, which are separated by wall L1217 but connected by a door opening.

As noted above, the walls of Room L-1 (**L1107**, L1121, L1428 and L1129) and those of Room L-2 (**L1107**, L1129, L1403, L1428 and L1493) were built over sand L1412 (Plate X). Walls L1232 and L1217 were erected directly over the basal, laminated strata referred *supra*, that is, no foundation sand was identified.

The foundation of Wall L1217 consists of six courses of mud bricks, the five lower ones disposed obliquely and the remaining one laid horizontally. Seven courses of mud bricks remain in the upper part. This wall features an opening (probably the place for a door) which connects rooms L-4 and L-5. It Wall L1232 limits Room L-5 by the SSE. Its foundation consists of three courses of horizontally laid mud bricks, and ten courses

remain in the upper part.

Rooms of Building L

Rooms L-1 and L-2

Between the erection of the walls and the first occupational surface, a thick stratum was formed by:

- a first refilling layer (**L1406**) about 20 cm thick. It was created by throwing sand containing charcoal and broken pottery;
- a layer of clean sand (**L1124**) some 12 cm thick;
- a layer (**L1126**) formed by sand, charcoal and big sherds in angular position, indicating that no treading took place. It is interpreted as a new refilling;
- a clayey layer (Arabic *muna*) (L 1127 in Room L-1 and **L1404** in Room L-2), which is interpreted as floor preparation mainly formed by clay and sand.

The first floor of Room L-2 is **L1125**, a thin layer rich in charcoal and ash. Floor of Room L-1 received two numbers (**L1122** and **L1123**), according to local differences in charcoal contents.

This first occupational level is covered by **L1407**, which is lighter in colour, less organic and includes a fallen mud brick. It seems to correspond to a lapse of abandonment or/and refurbishment of the building. Floor **L1112-1102bis** followed. Again, a layer of *muna* was spread, in order to prepare another floor, **L1102**.

Floors L1112-1102bis and L1102 are respectively linked to two superimposed stone door sockets (T6 and T5) in wall L1403, a clear indication of the refurbishment of the room. The lower socket (the one linked to floor L1102 bis) was carved in a squared block of limestone. In order to place it, some bricks were cut. It went into disuse and was sealed by floor L1102, which in turn was linked to another, raised socket, made of an unidentified kind of stone.

After this phase, wall L1121 in Room L-1 was sealed by sediments (L1110 and overlying layers), an indication that it had ceased to be functional. But the area continued in use, as indicated by several pots (found smashed *in situ*) associated with dark, carbonaceous lenses (**L1104** and L1108).

In room L-1, the intermediate stage between the decay of Building L and the erection of Building D is layer **L1400**, a *ridim* (Arabic for undifferentiated sediment) with numerous hearths, ash concentrations and combustion zones.

Room L-3

The excavation of this room could not be completed; the working space was too constrained by the walls of both Building L and D. In consequence, lower levels could not be reached until now.

Room L-3 is limited by north and east by wall L1418, taken to be contemporary with the other walls of Building L. Above this wall, **L1421** is a clayish sediment, probably formed by the decay of the walls of Building L and the local equivalent of L1219 in rooms L-4 and L-5. Hearth **L1423** is a hint that a very similar process to the one described in L1221 of Room L-4 took place, in which the remains of the building served as shelters for new settlers. On top of this level, L1422, probably a floor preparation, lies below floor **L1417**, a carbonaceous filling, in which small pieces of charcoal, sherds, a limestone mortar and a turtle shell (*Trionix* sp., Cione personal communication.) were found. Finally, above of and framing the excavated area of L1417, lay the walls of Building D.

Room L-4

Floor preparation consisted of a thick series of alternate lenses of sand and dark fill (from below, the order is L1237, **L1236**, **L1228** and **L1229**). L1237 is a clean sand, L1236

showed some lamination and had many sherds. L1228 was, again, a clean sand, but formed compact lumps. L1229 is a softer, darker fill. Floor **L1225** was very thin preserved only in patches. It is contemporary with floor L1224 of adjoining room L-5.

Room L-5

The living surface was prepared disposing two layers: L1230 and L1431. Basal layer **L1230** included an abundance of small sherds in angular disposition and fish bones. Overlying L1431 consisted in a series of thin sand lenses, probable remains of a continuous sand layer partly eroded by human frequentation of the floor **L1224**.

Floor L1224 is thin and laminated. In the western part of the excavated area there was a group of storage vessels still in place.

Recapitulation

Building L went through four phases of utilization or refurbishment: 1) floor L1125; 2) floor L1102bis; 3) floor L1102; 4) activity area L1400 which covered wall L1121.

Archaeological material

L1102 (Fig. 11)

I.- Pottery

a) Egyptian pottery

Nile silt clay

Household ware

No. 1: bowl (Fig. 11:1), Inv. No. C-1075 (2) [001]

Uncoated	Nile B ₂	W ₂
----------	---------------------	----------------

Rim sherd; everted articulated simmetrical rim, trimmed lip. Rd: 18.00 cm 3/32; Wd: 0.85 cm; H₁: 3.34 + x cm; smoothed on the wheel.

No. 2: bowl (Fig. 11:1), Inv. No. C-1305 bis (2) [003]

Uncoated	Nile B ₂	W ₂
----------	---------------------	----------------

Rim sherd; everted articulated exterior rim. Rd: 20.00 cm 3/32; Wd: 0.87 cm; H₁: 3.77 + x cm; smoothed on the wheel. Another, Rd: 22.00 cm 1/32.

No. 3: juglet, Inv. No. C-1305 bis (2) [024]

Uncoated	Nile B ₂	Ha ₂
----------	---------------------	-----------------

Handle fragment; simple vertical loop handle. Hd: 2.00 x 1.50 cm; smoothed.

No. 4: jar (Fig. 11:1), Inv. No. C-1303 (2) [002]

Uncoated	Nile B ₂	W ₂
----------	---------------------	----------------

Rim sherd; inverted direct rim. Rd: 11.00 cm 5/32; Wd: 0.73 cm; H₁: 3.39 + x cm; throwing lines inside; smoothed on the wheel. Another, Rd: 8.00 cm 1/2.

No. 5: jar (Fig. 11:1), Inv. No. C-1305 bis (2) [006]

Uncoated	Nile B ₂	W ₂
----------	---------------------	----------------

Rim sherd; inverted articulated exterior rim. Rd: 14.00 cm 3/16; Wd: 0.68 cm; H₁: 3.00 + x cm; throwing lines inside; smoothed on the wheel; eroded.

No. 6: jar (Fig. 11:1), Inv. No. C-1305 bis (2) [002]

Uncoated	Nile B ₂	W ₂
----------	---------------------	----------------

Rim sherd; vertical direct rim. Rd: 12.00 cm 3/16; Wd: 0.76 cm; H₁: 3.15 + x cm; throwing

lines inside; smoothed on the wheel. Others, Rd: 10.00 cm 1/8, Rd: 10.00 cm 1/8, Rd: 16.00 cm 3/32.

No. 7: jar, Inv. No. C-1305 bis (2) [005]

Uncoated Nile B₂ W₂

Rim sherd; everted articulated exterior rim. Rd: 17.00 cm 3/16; Wd: 0.94 cm; H₁: 8.47 + x cm; throwing lines inside; smoothed on the wheel.

No. 8: jar, Inv. No. C-1305 bis (2) [017]

Uncoated Nile B₂ W₂

Base fragment; flattened base. Bd: 8.00 cm 1/4; Wd: 0.50 cm; H₁: 4.60 + x cm; throwing lines inside; smoothed on the wheel.

No. 9: jar, Inv. No. C-1305 bis (2) [016]

Uncoated Nile C₁ W₁

Base fragment; rounded base. Wd: 0.69 cm; H₁: 2.30 + x cm; throwing lines inside; smoothed on the wheel.

No. 10: jar, Inv. No. C-1305 bis (2) [018]

Uncoated Nile B₂ W₂

Base fragment; flat base. Bd: 8.00 cm 1/4; Wd: 0.50 cm; H₁: 4.60 + x cm; throwing lines; smoothed on the wheel.

No. 11: jar, Inv. No. C-1305 bis (2) [022]

Uncoated Nile B₂ Ha₂

Handle fragment; simple vertical loop handle. Hd: 2.90 x 1.90 cm; eroded. Others, Hd: 3.10 x 2.40 cm; Hd: 3.60 x 2.30 cm; Hd: 3.00 x 1.60 cm.

No. 12: storage jar, Inv. No. C-1305 bis (2) [001]

Uncoated Nile B₂ W₂

Rim sherd; inverted articulated exterior rim. Rd: 28.00 cm 3/32; Wd: 1.58 cm; H₁: 9.00 + x cm; throwing lines inside; smoothed on the wheel; eroded.

No. 13: storage jar (Fig. 11:1), Inv. No. C-1043 [001]

Uncoated Nile B₂ W₂

Rim sherd; everted articulated exterior rim. Rd: 30.00 cm 1/16; Wd: 1.00 cm; H₁: 8.00 + x cm; throwing lines inside; smoothed on the wheel.

Pottery with special functions

No. 14: bakery tray, Inv. No. C-1305 bis (2) [011]

Uncoated Nile C₂ W₁ Ha

Complete, fragmentary; rim and base fragment; everted direct rim; flattened base. Rd: 20.00 cm 1/4; Bd: 20.00 cm 1/4; Wd: 1.44 cm; H₁: 3.60 + x cm; finger prints on the base; eroded. Another (rim), Rd: 20.00 cm 3/32.

Egyptian marls

Household ware

No. 15: bowl, Inv. No. C-1305 bis (2) [010]

Uncoated Marl F W₂

Rim sherd; everted articulated exterior rim, rolled lip. Rd: 20.00 cm 1/4; Wd: 1.00 cm; H₁: 5.22 + x cm; throwing lines inside; smoothed on the wheel; smoked outside and inside

(used as a lid).

No. 16: juglet?, Inv. No. C-1075 (2) [002]

Uncoated	Marl F	Ha ₂
----------	--------	-----------------

Handle fragment; vertical loop handle. Wd: 0.60 cm; Hd: 1.30 x 0.70 cm; smoothed.

No. 17: jar (Fig. 11:1), Inv. No. C-1043 [003]

Uncoated	Marl F	W ₂
----------	--------	----------------

Rim sherd; vertical direct rim. Rd: 9.00 cm 7/16; Wd: 0.77 cm; H₁: 3.30 + x cm; smoked.

No. 18: jar, Inv. No. C-1305 bis (2) [019]

Uncoated	Marl F	Ha ₂
----------	--------	-----------------

Handle fragment; simple vertical loop handle. Hd: 3.10 x 2.40 cm; smoothed.

b) Imported pottery

Levantine fine ware

Bichrome ware

No. 19: jug or jar? (Fig. 11:1), Inv. No. P1189A (Drawing No. 0702)

WPBI	IV.TG 01	W ₂	---	ox.	3
------	----------	----------------	-----	-----	---

Body sherd. Md: 26.00 cm 1/16; Wd: 0.60 cm; H₁: 7.70 + x cm. Surface colour: 7.5YR 8/4 pink slip. Break: 5YR 6/6 reddish yellow. Decoration: horizontally painted lines, 1-2 mm wide, and a band, 19 mm wide, 7.5YR 2.5/1 black; a band 21 mm, 10R 3/4 dusky red. Surface treatment: polished, medium lustre.

Levantine household ware

No. 20: juglet (Fig. 11:2), Inv. No. P7043A (Drawing No. 0921)

RP?	IV.TG 18	W ₂ + Ha ₂	---	re.	3
-----	----------	----------------------------------	-----	-----	---

Body and handle fragment. Md: ca. 11.00 cm; Wd: 1.40 cm; H₁: 8.50 + x cm; Hd: 1.80 x 1.40 cm. Surface colour: 7.5YR 6/4 light brown; 10R 5/6 red slip. Break: 7.5YR 5/1 grey interior; 6/1 grey exterior. Technical details: made in parts; throwing lines inside; neck open with a stick. Surface treatment: polished?

No. 21: amphora, IV.TG 18, body sherds, 0.10 dm².

No. 22: amphora, IV.TG 19, body sherds, 0.10 dm².

No. 23: amphora, IV.TG 22 = IV.Phoen? 04, body sherds, 0.30 dm².

No. 24: amphora, IV.TG 23, body sherds, 0.10 dm².

No. 25: amphora, IV.TG 32, body sherds, 0.10 dm².

No. 26: amphora, IV.TG 53 (= TD IV.09), body sherds, 0.20 dm².

No. 27: amphora, similar to TD IV.02, body sherds, 0.10 dm².

Cypriote household ware

No. 28: amphora, VI.TG 04, body sherds, 0.10 dm².

Aegean fine ware

Black on Red ware

No. 29: juglet (Fig. 11:2), Inv. No. P2032A (Drawing No. 0454)

RPMO	VII.TG 45	W ₂	---	ox.	3
------	-----------	----------------	-----	-----	---

Neck sherd. Nd: 2.00 cm 7/32; Wd: 0.30 cm; H₃: 1.70 + x cm. Surface colour: 10R 6/8 light red slip. Break: 10R 7/8 light red. Decoration: horizontally painted lines, 10R 3/2 dusky red. Surface treatment: polished, low lustre.

Aegean household ware

No. 30: amphora, VII.TG 08, body sherds, 0.10 dm².

No. 31: amphora, VII.TG 09, body sherds, 0.10 dm².

No. 32: amphora, VII.TG 39, body sherds, 0.30 dm².

No. 33: amphora, VII.TG 45, body shherds: 0.10 dm².

II.- Finds**Figurative art**

No. 34: terracotta zoomorphic figurine (a horse head?) (Fig. 11:2), Inv. No. F0800 (Drawing No. 0442). Fragmentary; clay; hand-made. 5.48 cm x 4.72 x 3.00 cm; colour: 7.5YR 5/4- 4/4 brown. SCA No. 4006.

Object of unknown use

No. 35: fragment of an object (Fig. 11:2), Inv. No. F0696A (Drawing No. 0619). Fragmentary; bronze; melted. 5.00 x 0.45 cm; round section; part of a large ring? *Find No. 002.*

L1104 (Fig. 12)**I.- Pottery****a) Egyptian pottery****Nile silt clay***Egyptian household ware*

No. 1: bowl (Fig. 12), Inv. No. C-1087 [003]

Uncoated	Nile B ₂	W ₂
----------	---------------------	----------------

Rim sherd; inverted direct rim. Rd: 18.00 cm 1/8; H₁: 3.94 + x cm; smoothed on the wheel; eroded.

No. 2: bowl (Fig. 12), Inv. No. C-1035 [006]

Uncoated	Nile B ₂	W ₂
----------	---------------------	----------------

Rim sherd; everted direct rim. Rd: 20.00 cm 3/8; Wd: 0.65 cm; H₁: 1.90 + x cm; smoothed on the wheel. Others, Rd: 20.00 cm 5/32, Rd: 26.00 cm 5/64. Nile C₁, Rd: 26.00 cm 3/16.

No. 3: deep bowl (Fig. 12), Inv. No. C-1035 [004]

Uncoated	Nile B ₂ /E ₁	W ₂
----------	-------------------------------------	----------------

Rim sherd; everted direct rim. Rd: 18.00 cm 1/8; Wd: 0.77 cm; H₁: 5.00 + x cm; smoothed on the wheel.

No. 4: bowl (Fig. 12), Inv. No. C-1039 [003]

Uncoated	Nile B ₂	W ₂
----------	---------------------	----------------

Rim sherd; everted articulated exterior rim. Rd: 26.00 cm 3/16; Wd: 0.73 cm; H₁: 3.60 + x cm. Throwing lines outside; smoothed on the wheel; eroded outside, smoked inside. Others, Rd: 24.00 cm 3/32, Rd: 26.00 cm 3/16, Rd: 32.00 cm 1/32.

No. 5: bowl (Fig. 12), Inv. No. C-1036 [005]

Uncoated	Nile B ₂	W ₂
----------	---------------------	----------------

Rim and wall fragment; slightly carinated walls; inverted articulated interior and exterior rim. Rd: 18.00 cm 1/16; Wd: 0.69 cm; H₁: 4.40 + x cm. Throwing lines outside; smoothed on the wheel.

No. 6: jar (Fig. 12), Inv. No. C-1035 [002]

Uncoated	Nile B ₂	W ₂
----------	---------------------	----------------

Rim sherd; inverted articulated exterior rim. Rd: 12.00 cm 5/32; Wd: 0.70 cm; H₁: 3.00 + x cm. Throwing lines inside; smoothed on the wheel. Others, Rd: 10.00 cm 5/32, Rd: 12.00 cm 1/8.

No. 7: jar (Fig. 12), Inv. No. C-1036 [002]

Uncoated	Nile B ₂	W ₂
----------	---------------------	----------------

Rim sherd; vertical direct rim. Rd: 10.00 cm 3/16; Wd: 0.50 cm; H₁: 4.10 + x cm. Throwing lines inside; smoothed on the wheel. Others, Rd: 10.00 cm 1/16, Rd: 10.00 cm 5/64.

No. 8: jar (Fig. 12), Inv. No. C-1039 [004]

Uncoated	Nile B ₂	W ₂
----------	---------------------	----------------

Rim sherd; everted direct rim. Rd: 8.00 cm 5/32; Wd: 0.45 cm; H₁: 3.60 + x cm; smoothed on the wheel. Others, Rd: 8.00 cm 5/32, Rd: 9.00 cm 1/8.

No. 9: storage jar (Fig. 12), Inv. No. C-1087 [001]

Uncoated	Nile B ₂	W ₂
----------	---------------------	----------------

Rim sherd; everted articulated exterior rim. Rd: 20.00 cm 5/32; H₁: 4.15 + x cm. Throwing lines inside; smoothed on the wheel. Another, Rd: 18.00 cm 3/32.

No. 10: storage jar (Fig. 12), Inv. No. C-1087 [008]

Uncoated	Nile B ₂	W ₂
----------	---------------------	----------------

Rim sherd; modelled rim. Rd: 20.00 cm 5/32; H₁: 3.00 + x cm. Throwing lines inside; smoothed on the wheel.

No. 11: storage jar, Inv. No. C-1035 [008]

Uncoated	Nile B ₂	W ₂
----------	---------------------	----------------

Body sherd; Md: ca. 24.00 cm; Wd: 0.80 cm; H₁: 6.90 + x cm. Throwing lines inside; smoothed on the wheel.

No. 12: handle, Inv. No. C-1035 [005], Nile B₂, Hd: 3.83 x 2.00 cm. Nile C₁, Hd: 3.68 x 1.85 cm.

Pottery with special functions

No. 13: tray, Inv. No. C-1039, Nile B₂, Nile C₂, 5 fragments.

Egyptian marls

Household ware

No. 14: amphora, Inv. No. C-1087 [017]

Uncoated	Marl F	Ha ₂ + W ₂
----------	--------	----------------------------------

Handle and body fragment; loop handle. H₁: 10.88 + x cm; Hd: 2.40 x 1.66 cm; smoothed.

Body sherds, Nile B₂, Nile C₂, Marl A₄, Marl F, Marl F s.

b) North Sinai/South Palestine pottery

Household ware

No. 15: amphora, II.TG 08, body sherd.

c) Imported pottery

Levantine Household ware

No. 16: juglet, Inv. No. C-1036 [006]

Uncoated	IV.TG 23	Ha ₂ + W ₂
----------	----------	----------------------------------

Handle fragment; Hd: 0.80 x 0.80 cm.

No. 17: amphora, Inv. No. C-1035 [001]

Uncoated	IV.TG 03	W ₂
----------	----------	----------------

Rim sherd; everted direct rim. Rd: 9.00 cm 3/8; H₁: 4.18 + x cm. Body sherds.

No. 18: amphora, IV.TG 29, body sherds.

No. 19: amphora, IV.TG 51 (=TD IV.19), body sherds.

No. 20: amphora (Fig. 12), Inv. No. C-1087 [006]

Uncoated	IV.TG 57 (=TD IV.12)	W ₂
----------	----------------------	----------------

Rim sherd; vertical direct rim. Rd: 10.00 cm 3/32; H₁: 3.96 + x cm. Body sherds.

No. 21: amphora, = TD IV.21, body sherds.

Cypriote household ware

No. 22: amphora, VI.TG 44, body sherds.

Aegean fine ware

Black-on-Red ware

No. 23: juglet (Fig. 12), Inv. No. P0809A (Drawing No. 0950)

RPMO	VII.TG 39	W ₂	---	ox.	3
------	-----------	----------------	-----	-----	---

Body sherd. Md: 8.30 cm 3/32 cm; Wd: 0.40 cm; H₁: 2.80 cm. Surface colour: 10R 4/6 red slip. Break: 2.5 YR 6/6 light red outside and 5YR 6/4 light reddish brown inside. Technical details: throwing lines inside. Decoration: five horizontally painted lines, 1 mm wide, 5YR 2.5/1 black. Surface treatment: polished, high lustre.

II.- Finds

Object of unknown use

No. 24: fragment of an object, Inv. No. F0289A; faience. *Find No. 002*.

No. 25: fragments (2) of an object, Inv. No. F0309 (Drawing No. 0619). Bronze; melted.
1) 2.70 x 0.80 cm; 2) 2.10 x 0.50 cm. *Find No. 005*.

L1107 (Fig. 13)

I.- Pottery

Egyptian pottery

Nile silt clay

Household ware

No. 1: bowl (Fig. 13), Inv. No. C-1076 [001]

Uncoated	Nile B ₂	W ₂
----------	---------------------	----------------

Rim sherd; everted direct rim; trimmed lip. Rd: 24.00 cm 1/16; H₁: 4.00 + x cm; smoothed on the wheel; smoked inside (used as a lid?).

No. 2: jar (Fig. 13), Inv. No. C-1071 [001]

Uncoated	Nile B ₂	W ₂
----------	---------------------	----------------

Rim sherd; slightly inverted direct rim, flat lip. Rd: 18.00 cm 1/4; Wd: 0.65 cm; H₁: 11.40 + x cm; throwing lines inside; smoothed on the wheel; eroded.

No. 3: jar, Inv. No. C-1071 [002]

Uncoated	Nile B ₂	W ₂	base finished on the wheel		
----------	---------------------	----------------	----------------------------	--	--

Base fragment; pointed base. Wd: 1.55 cm; H₁: 4.40 + x cm; finger marks and throwing lines inside; smoothed on the wheel; eroded.

No. 4: jar or storage jar?, Inv. No. C-1071 [003]

Uncoated	Nile B ₂	Ha ₂
----------	---------------------	-----------------

Handle fragment; very eroded.

Body sherds, Nile B₂.

b) Imported pottery

Levantine household ware.

No. 5: amphora, IV.TG 11, body sherd.

Aegean fine ware

Black-on-Red ware

No. 6: juglet (Fig. 13), Inv. No. P2007A (Drawing No. 0444)

RPMO	VII.TG 39	W ₂	---	ox.	3
------	-----------	----------------	-----	-----	---

Rim and neck fragment; compound neck, everted direct rim. Rd: 2.86 cm; Nd: 1.37 cm; Wd: 0.20 cm; H₁: 3.08 + x cm. Surface colour: 2.5YR 6/8 light red. Break: 2.5YR 6/8 light red. Technical details: throwing lines inside. Decoration: horizontally painted bands around the rim and neck, 2.5YR 3/1 dark reddish grey. Surface treatment: polished, low lustre.

L1108

Pottery

Egyptian pottery: Inv. No. C-1040, body sherds, Nile B₂, Nile C₁.

Levantine pottery: Inv. No. C-1040, body sherds, IV.TG 51 (=TD IV.19).

L1112 = L1102bis (Fig. 14)

I.- Pottery

a) Egyptian pottery

Nile silt clay

Household ware

No. 1: bowl (Fig. 14:1), Inv. No. C-1301 (2) [002]

RS	Nile B ₂	W ₂
----	---------------------	----------------

Rim sherd; inverted articulated interior rim. Rd: 18.00 cm 3/32; Wd: 0.60 cm; H₁: 2.16 + x cm; red slipped; smoothed on the wheel.

No. 2: bowl (Fig. 14:1), Inv. No. C-1301 (2) [005]

Uncoated	Nile B ₂	W ₂
----------	---------------------	----------------

Rim sherd; everted direct rim. Rd: 26.00 cm 1/8; Wd: 1.20 cm; H₁: 4.67 + x cm; smoothed on the wheel.

No. 3: bowl (Fig. 14:1), Inv. No. C-1301 (2) [003]

Uncoated	Nile C ₁	W ₂
----------	---------------------	----------------

Rim sherd; everted articulated exterior rim, rolled lip. Rd: 22.00? cm 1/32; Wd: 1.00 cm; H₁: 4.29 + x cm; smoothed on the wheel.

No. 4: bowl, Inv. No. C-1058 [006]

Uncoated	Nile C ₁	W ₂	base finished on the wheel
----------	---------------------	----------------	----------------------------

Base fragment; pointed base. Wd: 0.90 cm; H₁: 4.80 + x cm; smoothed on the wheel; eroded inside.

No. 5: globular jar (Fig. 14:1), Inv. No. C-1301 (2) [006]

Uncoated	Nile B ₂	W ₂
----------	---------------------	----------------

Rim sherd; everted direct rim. Rd: 10.00 cm 1/2; Wd: 0.80 cm; H₁: 6.20 + x cm; throwing lines inside; smoothed on the wheel.

No. 6: jar? (Fig. 14:1), Inv. No. C-1303 (2) [002]

Uncoated	Nile B ₂	W ₂
----------	---------------------	----------------

Rim sherd; inverted direct rim Rd: 15.00 cm 5/32; Wd: 0.73 cm; H₁: 3.39 + x cm; throwing lines inside; smoothed on the wheel. Another, Rd: 8.00 cm 1/8.

No. 7: jar (Fig. 14:1), Inv. No. C-1303 (2) [001]

Uncoated	Nile B ₂	W ₂
----------	---------------------	----------------

Rim sherd; vertical direct rim. Rd: 16.00 cm 3/32; Wd: 1.50 cm; H₁: 3.30 + x cm; throwing lines inside; smoothed on the wheel.

No. 8: jar (Fig. 14:1), Inv. No. C-1058 [003]

Uncoated	Nile B ₂	W ₂
----------	---------------------	----------------

Rim and body fragment; vertical articulated interior and exterior rim, trimmed lip. Rd: 18.00 cm 1/8; Wd: 1.00 cm; H₁: 6.30 + x cm; throwing lines inside; smoothed on the wheel; eroded.

No. 9: storage jar (Fig. 14:1), Inv. No. C-1058 [001]

Uncoated	Nile B ₂	W ₂
----------	---------------------	----------------

Rim and body fragment; inverted articulated exterior rim, round lip. Rd: 20.00 cm 3/16; Wd: 1.25 cm; H₁: 6.80 + x cm; throwing lines inside; smoothed on the wheel.

No. 10: storage jar (Fig. 14:1), Inv. No. C-1301 (2) [004]

Uncoated	Nile B ₂	W ₂
----------	---------------------	----------------

Rim sherd; vertical direct rim. Rd: 20.00 cm 3/32; Wd: 0.74 cm; H₁: 3.85 + x cm; throwing lines inside; smoothed on the wheel.

No. 11: storage jar (Fig. 14:1), Inv. No. C-1301 (2) [007]

Uncoated	Nile B ₂	W ₂
----------	---------------------	----------------

Rim sherd; everted articulated interior and exterior rim, modelled lip. Rd: 30.00? cm 3/32; Wd: 1.75 cm; H₁: 5.86 + x cm; throwing lines inside; smoothed on the wheel; eroded.

No. 12: amphora, Inv. No. C-1058 [010]

Uncoated	Nile C ₂	W ₂ + Ha ₂
----------	---------------------	----------------------------------

Handle and body fragment; vertical loop handle attached to the body. H₁: 14.30 + x cm; Hd: 3.20 x 3.30 x 3.10 cm, irregular section; eroded.

Pottery with special functions

No. 13: bakery tray (Fig. 14:1), Inv. No. C-1058 [004]

Uncoated	Nile C ₂	W ₁	Ha
----------	---------------------	----------------	----

Rim and base fragment; flat base; everted; direct rim Rd: 20.00 cm 3/16; Bd: 18.00 cm 3/32; Wd: 1.40 cm; H₁: 4.90 cm. VI: 408; throwing lines inside; eroded inside.

Egyptian marls**Household ware****No. 14: jar**, Inv. No. C-1058 [011]Uncoated | Marl F | Ha₂ + W₂Handle and body fragment; vertical loop handle. H₁: 5.00 + x cm; Hd: 3.10 x 1.60 cm; eroded.**No. 15: amphora** (Fig. 14:2), Inv. No. C-1058 [009]Uncoated | Marl F | Ha₂ + W₂Handle and body fragment. Md: 28.00 cm 3/32; Wd: 0.50 cm; H₁: 7.80 + x cm; Hd: 3.10 x 1.60 cm; smoothed.**Mixed clay,****Household ware****No. 16: large jar or storage jar?** (Fig. 14:2), Inv. No. C-1301 (2) [008]Uncoated | Nile and Egyptian marl | W₂Base fragment; round base. Md: 12.00 + x cm; Wd: 1.00 cm; H₁: 3.60 + x cm; throwing lines inside.**b) Imported pottery****Cypriote fine ware***White Painted ware***No. 17: bowl** (Fig. 14:2), Inv. No. P7044A (Drawing No. 0921)BPMO | VI.TG 04 | W₂ | --- | ox. | 3Rim sherd and swelling of the handle. Rd: 20.0 cm 1/16; Wd: 0.55 cm; H₁: 2.80 + x cm. Surface colour: 10YR 6/4 light yellowish brown slip. Break: 10YR 7/4 very pale brown. Decoration: two horizontally painted bands, 5 mm wide, and another around the handle, 10YR 3/2 very dark greyish brown. Surface treatment: polished, low lustre.**Aegean household ware****No. 18: amphora**, VII.TG 39, body sherds, 0.10 dm².**No. 19: amphora**, VII.TG 45, body sherds: 0.20 dm².**II.- Finds****Grinding stone****No. 20: hand** (Fig. 14:2), Inv. No. F0538A (Drawing No 0333/1052). Fragmentary; conglomeradic. Sandstone; colour: black. Weight: 288.00 gr. 7.70 x 4.80 x 4.80 cm. Degree of wear: 3-Hard. Wear type: abrasion. Wear marks: fine striations. Surfaces: 1. Surface configuration: flat-convex. Surface texture: slightly coarse. Stroke: 2 directions.**L1122 (Fig. 15)****I.- Pottery****a) Egyptian pottery****Nile silt clay****Household ware****No. 1: bowl** (Fig. 15), Inv. No. C-1086 [003]Uncoated | Nile B₂ | W₂Rim sherd; inverted articulated exterior rim. Rd: 20.00 cm 1/16; Wd: 0.68 cm; H₁: 3.24 + x cm. Smoothed on the wheel.

No. 2: bowl (Fig. 15), Inv. No. C-1086 [001]Uncoated Nile C₁ W₂Rim sherd; inverted direct rim. Rd: 26.00 cm 5/64; Wd: 0.75 cm; H₁: 3.00 + x cm. Smoothed on the wheel.**No. 3: bowl (Fig. 15), Inv. No. C-1086 [002]**Uncoated Nile B₂ W₂Rim sherd; everted articulated interior and exterior rim. Rd: 20.00 cm 5/64; Wd: 0.75 cm; H₁: 2.55 + x cm. Smoothed on the wheel.**No. 4: jar (Fig. 15), Inv. No. C-1086 [006]**Uncoated Nile B₂ W₂Rim sherd; vertical direct rim. Rd: 9.00 cm 5/32; Wd: 0.44 cm; H₁: 3.30 + x cm. Throwing lines inside; smoothed on the wheel. Another, Rd: 12.00 cm 1/86.**No. 5: jar (Fig. 15), Inv. No. C-1086 [004]**Uncoated Nile B₂ W₂Rim sherd; slightly everted direct rim. Rd: 12.00 cm 1/8; Wd: 0.63 cm; H₁: 3.50 + x cm. Throwing lines inside; smoothed on the wheel.**No. 6: storage jar (Fig. 15), Inv. No. C-1086 [007]**Uncoated Nile B₂ W₂Rim sherd; everted articulated exterior rim, folded lip. Rd: 20.00 cm 1/8; Wd: 0.80 cm; H₁: 3.62 + x cm. Smoothed on the wheel.Body sherds, Nile B₂: 7.00 dm²; Nile C₂: 0.25 dm².**II.- Finds****Tool****No. 7: sharpener**, Inv. No. F0405A. Pumice. 4.50 x 3.70 x 2.60 cm. *Find No. 020.***L1123 (Fig. 16)****I.- Pottery****Egyptian pottery****Nile silt clay****Household ware****No. 1: bowl (Fig. 16), Inv. No. C-1046 [006]**Uncoated Nile B₂ W₂Rim sherd; everted direct rim. Rd: 24.00 cm 1/32; Wd: 0.50 cm; H₁: 1.30 + x cm; smoothed on the wheel; eroded below the rim. Another, Rd: 20.00 cm 1/32.**No. 2: cup (Fig. 16), Inv. No. C-1046 [007]**Uncoated Nile B₂ W₂Rim sherd; slightly everted direct rim. Rd: 10.00 cm 1/16; Wd: 0.30 cm; H₁: 1.90 + x cm. Throwing lines inside and outside; smoothed on the wheel.**No. 3: jar (Fig. 16), Inv. No. C-1046 [004]**Uncoated Nile B₂ W₂Rim sherd; vertical direct rim. Rd: 9.00 cm 1/16; Wd: 0.50 cm; H₁: 2.50 + x cm. Throwing lines inside; smoothed on the wheel. Others, Rd: 12.00 cm 1/16, Rd: 9.00 cm 3/32.

No. 4: jar, Inv. No. C-1046 [008]

Uncoated	Nile B ₂	W ₂	W
----------	---------------------	----------------	---

Base fragment; round base. H₁: 1.80 + x cm. Throwing lines inside; smoothed on the wheel.

No. 5: storage jar (Fig. 16), Inv. No. C-1046 [001]

Uncoated	Nile B ₂	W ₂
----------	---------------------	----------------

Rim sherd; inverted articulated interior rim, round lip. Rd: 29.00 cm 3/32; Wd: 1.00 cm; H₁: 4.50 + x cm. Throwing lines inside; smoothed on the wheel.

Body sherds, Nile B₂: 7 dm².

Egyptian marls

Fine ware

No. 6: juglet, Inv. No. P1262A (Drawing No. 0703)

RP	Marl F s.	W ₂	---	ox.	3
----	-----------	----------------	-----	-----	---

Body sherd. Md: ca. 6.00 cm; Wd: 0.35 cm; H₁: 1.20 + x cm. Surface colour: 10R 4/4 weak red slip. Break: 5YR 5/6 yellowish red. Technical details: throwing lines inside. Surface treatment: polished, medium lustre.

b) Imported pottery

Aegean fine ware

No. 7: jar (Fig. 16), Inv. No. P0782A (Drawing No. 0654)

BP	VII.TG 39	W ₂	base finished on the wheel		ox.	3
----	-----------	----------------	----------------------------	--	-----	---

Base fragment; ring base (R₂). Bd: 5.00 cm 1/4; Wd: 0.50 cm; H₁: 4.10 + x cm. Surface colour: 5YR 4/4 reddish brown slip. Break: 5YR 6/6 reddish yellow. Technical details: throwing lines inside. Surface treatment: polished, medium lustre.

II.- Finds

Product

No. 8: faience slag, Inv. No. F0336A. *Find No. 017.*

L1124 (Fig. 17)

I.- Pottery

a) Egyptian pottery

Nile silt clay

Household ware

No. 1: bowl (Fig. 17), Inv. No. C-1304 (2) [007]

Uncoated	Nile C ₁	W ₂
----------	---------------------	----------------

Rim sherd; incurved walls; inverted articulated interior rim, trimmed lip. Rd: 24.00 cm 1/16; Wd: 0.80 cm; H₁: 4.10 + x cm; throwing lines outside; eroded; smoked inside and outside (used as a lid?).

No. 2: bowl (Fig. 17), Inv. No. C-1304 (2) [008]

Uncoated	Nile C ₂	W ₂
----------	---------------------	----------------

Rim sherd; everted articulated exterior rim, trimmed lip. Rd: 24.00 cm 1/16; Wd: 1.00 cm; H₁: 3.00 + x cm; smoothed on the wheel; eroded.

No. 3: cup (Fig. 17), Inv. No. C-1304 (2) [001]

Uncoated	Nile C ₁	W ₂
----------	---------------------	----------------

Rim sherd; incurved wall. Rd: 10.00 cm $\frac{3}{32}$; Wd: 0.40 cm; H_1 : 4.30 + x cm; throwing lines inside; smoothed on the wheel. Another, Nile B₂, Rd: 10.00 cm $\frac{1}{8}$.

No. 4: jar (Fig. 17), Inv. No. C-1304 (2) [004]

Uncoated Nile C₁ W₂

Rim sherd; inverted direct rim. Rd: 10.00 cm $\frac{5}{32}$; Wd: 0.50 cm; H_1 : 3.80 + x cm; throwing lines inside; smoothed on the wheel; eroded.

No. 5: jar (Fig. 17), Inv. No. C-1304 (2) [002]

Uncoated Nile B₂ W₂

Rim sherd; everted direct rim. Rd: 12.00 cm $\frac{1}{8}$; Wd: 1.00 cm; H_1 : 4.00 + x cm; throwing lines inside; smoothed on the wheel; eroded. Others, Rd: 12.00 cm $\frac{1}{8}$. Nile C₁, Rd: 12.00 cm $\frac{1}{8}$.

No. 6: jar, Inv. No. C-1304 (2) [017]

Uncoated Nile B₂ Ha₂

Handle fragment; Hd: 2.50 x 1.80 cm; eroded. Another, Hd: 2.50 x 1.90 cm.

No. 7: jar?, Inv. No. C-1304 (2) [012]

Uncoated Nile B₂ W₂

Neck and body fragment; Wd: 0.90 cm; H_1 : 6.60 + x cm; throwing lines inside; smoothed on the wheel; eroded.

No. 8: jar, Inv. No. C-1304 (2) [014]

Uncoated Nile B₂ W₂ base finished on the wheel

Base fragment; pointed base. Wd: 1.40 cm; H_1 : 2.50 + x cm; throwing lines inside and outside; smoothed on the wheel; smoked inside?; eroded. Another, 1 base.

No. 9: jar, Inv. No. C-1304 (2) [015]

Uncoated Nile C₁ Ha₂

Handle fragment. Hd: 3.80 x 2.35 cm; smoothed. Others, Hd: 2.20 x 1.90 cm; Hd: 2.60 x 2.10 cm; Hd: 3.50 x 2.45 cm.

No. 10: storage jar (Fig. 17), Inv. No. C-1304 (2) [013]

Uncoated Nile C₂ W₂

Rim sherd; inverted articulated interior and exterior, modelled lip. Rd: 22.00 cm $\frac{1}{4}$; Wd: 0.90 cm; H_1 : 4.70 + x cm; throwing lines inside; smoothed on the wheel; eroded.

No. 11: storage jar (Fig. 17), Inv. No. C-1304 (2) [006]

Uncoated Nile B₂ W₂

Rim sherd; inverted articulated interior and exterior rim, rolled lip. Rd: 22.00 cm $\frac{1}{16}$; Wd: 0.90 cm; H_1 : 4.50 + x cm; throwing lines outside; smoothed on the wheel; eroded.

No. 12: storage jar (Fig. 17), Inv. No. C-1304 (2) [010]

Uncoated Nile C₁ W₂

Rim sherd; inverted articulated interior rim, folded lip. Rd: 20.00 cm $\frac{1}{8}$; Wd: 1.20 cm; H_1 : 5.20 + x cm; throwing lines inside; smoothed on the wheel; eroded inside and outside.

No. 13: storage jar (Fig. 17), Inv. No. C-1304 (2) [009]

Uncoated Nile C₁ W₂

Rim sherd; everted direct rim. Rd: 22.00 cm $\frac{3}{32}$; Wd: 1.00 cm; H_1 : 3.70 + x cm;

throwing lines inside; smoothed on the wheel.

No. 14: storage jar, Inv. No. C-1304 (2) [021]

Uncoated	Nile C ₁	W ₂
----------	---------------------	----------------

Body sherd; incurved wall; Wd: 1.30 cm; throwing lines inside; eroded.

Pottery with special functions

No. 15: bakery tray (Fig. 17), Inv. No. C-9079 [001]

Uncoated	Nile B ₂	W ₁	Ha
----------	---------------------	----------------	----

Rim and base fragment; flat base, everted direct rim. Rd: 24.00 cm 1/8; Bd: 22.00 cm 5/32; Wd: 1.35 cm; H₁: 4.50 cm. VI: 533; smoothed by hand.

Body sherds, Nile B₂, Nile C₂, Nile C₂ c., Marl A₄, Marl F, Marl F v.s.

b) North Sinai/South Palestine pottery

Household ware

No. 16: amphora, II.TG 09, body sherds.

c) Imported pottery

Household ware

No. 17: amphora, IV.TG 51 (=TD IV.19), body sherds.

No. 18: amphora, IV.TG 53 (=TD IV.09), body sherds.

No. 19: amphora, IV.TG 57 (=TD IV.12), body sherds.

II.- Finds

Product

No. 20: slag, Inv. No. F0796A. *Find No. 007.*

L1125 (Fig. 18)

I.- Pottery

a) Egyptian pottery

Nile silt clay

Household ware

No. 1: [globular] jar (Fig. 18), Inv. No. C-1085 (2) [001]

Uncoated	Nile C ₂	W ₂
----------	---------------------	----------------

Rim sherd; everted direct rim. Rd: 10.00 cm 1/8; Wd: 0.40 cm; H₁: 3.70 + x cm; throwing lines inside; eroded.

No. 2: jar (Fig. 18), Inv. No. C-1338 (2) [005]

Uncoated	Nile B ₂	W ₂
----------	---------------------	----------------

Rim sherd; vertical direct rim. Rd: 16.00 cm; Wd: 1.20 cm; H₁: 7.50 + x cm; throwing lines inside; smoothed on the wheel. Another, Rd: 16.00 cm 1/8.

No. 3: jar (Fig. 18), Inv. No. C-1338 (2) [006]

Uncoated	Nile B ₂	W ₂
----------	---------------------	----------------

Rim sherd; vertical articulated exterior rim, rolled lip, trimmed. Rd: 18.00 cm; Wd: 1.10 cm; H₁: 4.00 + x cm; throwing lines inside; smoothed on the wheel.

No. 4: jar, Inv. No. C-1338 (2) [001]

Uncoated	Nile B ₂	W ₂
----------	---------------------	----------------

Rim sherd; everted direct rim. Rd: 16.00 cm 1/8; Wd: 1.00 cm; H₁: 9.00 + x cm; throwing

lines inside; smoothed on the wheel.

No. 5: storage jar (Fig. 18), Inv. No. C-1338 (2) [002]

Uncoated	Nile B ₂	W ₂
----------	---------------------	----------------

Rim sherd; inverted articulated interior and exterior rim, rolled lip. Rd: 20.00 cm 3/32; Wd: 0.80 cm; H₁: 6.00 + x cm; throwing lines inside; smoothed on the wheel.

b) Imported pottery

Levantine fine ware

No. 6: bowl (Fig. 18), Inv. No. P2037A (Drawing No. 0703)

WPMO	IV.TG 01	Ha ₂ + W ₂	---	ox.	3
------	----------	----------------------------------	-----	-----	---

Handle and body fragment; horizontal handle; 1; single strap. Md: 7.00 cm 5/32; Wd: 0.30 cm; Hd: 0.80 x 0.80 cm. Surface colour: 5YR 7/6 reddish yellow slip. Break: 5YR 6/6 reddish yellow. Decoration: a painted line along the handle, 9 mm wide, 5 YR 3/1 very dark grey. Surface treatment: polished, low lustre.

Household ware

No. 7: amphora, IV.TG 51 (= TD IV.19), body sherds, 0.10 dm².

Phoenician household ware

No. 8: amphora, IV.TG 35 = IV.Phoen.01, body sherds, 0.50 dm².

Cypriote household ware

No. 9: amphora, VI.TG 44, body sherds, 0.10 dm².

II.- Finds

No. 10: fragment of an object, Inv. No. F0693A. Bronze. 1.60 x 1.90 x 0.30 cm. Find No. 004.

L1126 (Fig. 19)

I.- Pottery

a) Egyptian pottery

Nile silt clay

Fine ware

No. 1: jug (Fig. 19:1), Inv. No. P7057A (Drawing No. 0926)

RP	Nile B ₂	W ₂	---	ox.	3
----	---------------------	----------------	-----	-----	---

Neck and handle fragment; compound neck; handle applied from the neck to the shoulder; 1; single strap. Nd: 6.00 cm 3/16; Wd: 0.55 cm; H₃: 3.40 + x cm; Hd: --- . Surface colour: 10R 5/8 red slip. Break: 5YR 5/6 yellowish red. Surface treatment: burnished.

Egyptian painted ware

Black on Red slip ware

No. 2: jar (Fig. 19:1), Inv. No. P7010A (Drawing No. 0902)

RSMO	Nile B ₂	W ₂	---	re.	2
------	---------------------	----------------	-----	-----	---

Body sherd. Md: 16.00 + x cm; Wd: 0.65 cm; H₁: 2.00 + x cm. Surface colour: 10R 5/4 weak red slip. Break: 2.5YR 3/1 dark reddish grey. Decoration: a horizontally painted band, 7 mm wide, 10R 4/1 dark reddish grey. Surface treatment: smoothed on the wheel. Eroded inside.

*Bichrome ware***No. 3: deep bowl** (Fig. 19:1), Inv. No. P1123A (Drawing No. 0524)

WPBI	Nile B ₁	W ₂	---	ox.	2
------	---------------------	----------------	-----	-----	---

Body sherd. Md: 9.20 + x cm; Wd: 0.25 cm; H₁: 3.00 + x cm. Surface colour: 5YR 7/4 pink slip. Break: 7.5YR 5/1 grey core; 2.5YR 5/6 red oxidation zones. Technical details: made in parts; fine ridges inside. Decoration: horizontally painted bands outside, 1-2 mm wide, with a black-red-black pattern (10R 4/6 red and 4/1 dark reddish grey). Surface treatment: polished, low lustre. Observations: very fine pot.

No. 4: jar (Fig. 19:1), Inv. No. P1127A (Drawing No. 0529)

WPBI	Nile E ₂	W ₂	---	ox.	2-3
------	---------------------	----------------	-----	-----	-----

Body sherd. Md: 10.80 + x cm; Wd: 0.45 cm; H₁: 5.20 + x cm. Surface colour: 5YR 7/4 pink slip. Break: 5YR 6/4 light red interior; 10YR 8/3 very pale brown exterior. Technical details: ridges inside. Decoration: four horizontally painted bands, 3 to 6 mm wide, 10R 5/6 red and 10R 5/1 reddish grey. Surface treatment: polished, low lustre.

*Egyptian household ware***No. 5: bowl?** (Fig. 19:1), Inv. No. C-1031 (2) [013]

Uncoated	Nile B ₂	W ₁
----------	---------------------	----------------

Rim sherd; incurved walls; inverted direct rim. Rd: 20.00 cm 1/32; Wd: 0.69 cm; H₁: 2.80 + x cm; smoothed on the wheel.

No. 6: bowl (Fig. 19:1), Inv. No. C-1031 (2) [003]

Uncoated	Nile B ₂	W ₁
----------	---------------------	----------------

Rim sherd; everted articulated exterior rim. Rd: 27.00 cm 3/32; Wd: 0.50 cm; H₁: 5.50 + x cm; smoothed on the wheel. Others, Rd: 18.00 cm 3/32; Rd: 26.00 cm 5/32.

No. 7: bowl (Fig. 19:2), Inv. No. C-1300 [033]

Uncoated	Nile B ₂	W ₂
----------	---------------------	----------------

Rim and wall fragment; everted direct rim. Rd: 34.00 cm 3/32; Wd: 0.90 cm; H₁: 5.70 + x cm; smoothed on the wheel. Others, Rd: 17.50 cm 3/16, Rd: 20.00 cm 3/64, Rd: 24.00 cm 1/2, Rd: 26.00 cm 1/2. Nile C₂, Rd: 30.00 cm 1/16.

No. 8: bowl (Fig. 19:2), Inv. No. C-1031 (2) [005]

Uncoated	Nile B ₂	W ₂
----------	---------------------	----------------

Rim and wall fragment; slightly carinated wall; everted articulated exterior rim, trimmed lip. Rd: 26.00 cm 1/16; Wd: 1.10 cm; H₁: 6.00 + x cm; throwing lines inside and outside; smoothed on the wheel.

No. 9: juglet (Fig. 19:2), Inv. No. C-1300 [027]

Uncoated	Nile B ₂	W ₂
----------	---------------------	----------------

Rim sherd; everted direct rim, flattened. Rd: 5.00 cm 1/8; Wd: 0.25 cm; H₁: 2.10 + x cm; throwing lines inside; smoothed on the wheel.

No. 10: globular jar (Fig. 19:2), Inv. No. C-1031 (2) [009]

Uncoated	Nile B ₂	W ₂
----------	---------------------	----------------

Rim sherd; everted direct rim. Rd: 10.00 cm 3/32; Wd: 0.50 cm; H₁: 5.00 + x cm; throwing lines inside; smoothed on the wheel. Others, Rd: 9.00 cm 1/4, Rd: 10.00 cm 1/4, Rd: 14.00 cm 3/32. Nile C₁, Rd: 10.00 cm 1/8.

No. 11: jar (Fig. 19:2), Inv. No. C-1300 [029]

Uncoated	Nile B ₂	W ₂
----------	---------------------	----------------

Rim sherd; inverted articulated exterior rim, modelled lip. Rd: 12.00 cm 1/8; Wd: 0.70 cm; H₁: 3.80 + x cm; throwing lines inside; smoothed on the wheel.

No. 12 : jar (Fig. 19:2), Inv. No. C-1300 [046]

Uncoated	Nile B ₂	W ₂
----------	---------------------	----------------

Rim sherd; inverted simmetric rim, round lip. Rd: 18.00 cm 1/8; Wd: 0.60 cm; H₁: 3.00 + x cm; throwing lines inside; smoothed on the wheel.

No. 13: jar (Fig. 19:2), Inv. No. C-1300 [015]

Uncoated	Nile B ₂	W ₂
----------	---------------------	----------------

Rim sherd; vertical direct rim. Rd: 9.00 cm 5/32; Wd: 0.40 cm; H₁: 4.20 + x cm; throwing lines inside; smoothed on the wheel. Others, Rd: 8.00 cm 1/8, Rd: 9.00 cm 1/8, Rd: 10.00 cm 1/1, Rd: 11.00 cm 1/4, Rd: 12.00 cm 5/32, Rd: 14.00 cm 1/2, Rd: 17.00 cm 5/32, Rd: 19.00? cm 1/64. Nile C₁, Rd: 10.00 cm 1/4.

No. 14: jar, Inv. No. C-1300 [022]

Uncoated	Nile B ₂	W ₂
----------	---------------------	----------------

Rim sherd; vertical direct rim, trimmed. Rd: 9.00 cm 1/8; Wd: 0.40 cm; H₁: 2.00 + x cm; throwing lines inside; smoothed on the wheel.

No. 15: jar, Inv. No. C-1300 (2) [003]

Uncoated	Nile B ₂	W ₂
----------	---------------------	----------------

Rim sherd; everted articulated exterior rim, round lip. Rd: 16.00 cm 1/8; Wd: 1.28 cm; H₁: 2.97 + x cm; throwing lines inside; smoothed on the wheel.

No. 16: jar, Inv. No. C-1300 [051]

Uncoated	Nile B ₂	W ₂	W
----------	---------------------	----------------	---

Base fragment; round base. Md: 12.00 cm; Wd: 0.60 cm; H₁: 3.80 + x cm; throwing lines inside; smoothed on the wheel. Others, 3 bases.

No. 17: jar, Inv. No. C-1300 [061]

Uncoated	Nile B ₂	Ha ₂
----------	---------------------	-----------------

Handle fragment; loop handle. Hd: 2.10 x 1.70 cm; smoothed. Another, Hd: 1.80 x 1.30 cm.

No. 18: storage jar, Inv. No. C-1300 (2) [001]

Uncoated	Nile B ₂	W ₂
----------	---------------------	----------------

Rim sherd; inverted simmetrical round rim. Rd: 20.00 cm 3/32; Wd: 0.76 cm; H₁: 4.33 + x cm; throwing lines inside; smoothed on the wheel.

No. 19: storage jar (Fig. 19:2), Inv. No. C-1300 [039]

Uncoated	Nile B ₂	W ₂
----------	---------------------	----------------

Rim fragment; inverted articulated interior and exterior rim, modelled lip. Rd: 30.00 cm 3/32; Wd: 0.90 cm; H₁: 5.50 + x cm; throwing lines inside, smoothed on the wheel. Others, Nile C₂, Rd: 37.00 cm 5/32, Rd: 34.00 cm 3/64.

No. 20: storage jar (Fig. 19:2), Inv. No. C-1300 [043]

Uncoated	Nile B ₂	W ₂
----------	---------------------	----------------

Rim fragment; inverted articulated interior rim, folded lip. Rd: 30.00 cm 5/32; Wd: 0.90 cm; H₁: 4.60 + x cm; throwing lines inside; eroded. Another, Rd: 29.00 cm 1/4.

No. 21: storage jar (Fig. 19:2), Inv. No. C-1300 [045]Uncoated | Nile B₂ | W₂Rim fragment; inverted articulated exterior rim, round lip. Rd: 26.00 cm 1/16; Wd: 0.80 cm; H₁: 3.50 + x cm; throwing lines inside; smoothed on the wheel.**No. 22: storage jar** (Fig. 19:2), Inv. No. C-1300 [047]Uncoated | Nile B₂ | W₂Rim fragment; inverted articulated exterior rim, trimmed lip. Rd: 24.00 cm 1/16; Wd: 0.60 cm; H₁: 3.30 + x cm; throwing lines inside; smoothed on the wheel.**No. 23: storage jar** (Fig. 19:3), Inv. No. C-1031 (2) [006]Uncoated | Nile B₂ | W₁Rim sherd; inverted articulated exterior rim. Rd: 32.00 cm; Wd: 1.00 cm; H₁: 5.00 + x cm; throwing lines inside; smoothed on the wheel.**No. 24: storage jar** (Fig. 19:3), Inv. No. C-1300 [042]Uncoated | Nile C₁ | W₂Rim sherd; inverted articulated interior rim, trimmed lip. Rd: 30.00 cm 1/16; Wd: 0.85 cm; H₁: 4.50 + x cm; throwing lines inside; smoothed on the wheel.**No. 25: storage jar** (Fig. 19:3), Inv. No. C-1031 (2) [002]Uncoated | Nile B₂ | W₂Rim and wall fragment; vertical articulated exterior rim. Rd: 30.00 1/16; Wd: 1.00 cm; H₁: 7.50 + x cm; throwing lines inside; partially smoked, eroded and salt incrustated.**No. 26: storage jar** (Fig. 19:3), Inv. No. C-1300 [026]Uncoated | Nile B₂ | W₂Rim sherd; vertical articulated exterior rim, round lip; long neck. Rd: 22.00 cm 7/32; Wd: 0.60 cm; H₁: 10.80 + x cm; throwing lines inside; smoothed on the wheel.**No. 27: storage jar**, Inv. No. C-1300 [057]Uncoated | Nile B₂ | Ha₂ + W₂Handle fragment; attached vertical loop handle. H₁: 6.00 + x cm; Hd: 4.10 x 2.30 cm; smoothed.**No. 28: amphora** (Fig. 19:3), Inv. No. C-1300 [030]Uncoated | Nile B₂ | W₂Rim sherd; inverted articulated exterior rim modelled lip. Rd: 16.00 cm 5/64; Wd: 0.55 cm; H₁: 2.50 + x cm; throwing lines inside; smoothed on the wheel.**Pottery with special functions****No. 29: lid** (Fig. 19:3), Inv. No. C-1300 (3) [006]Uncoated | Nile C₂ | W₂Rim and wall fragment; everted direct rim. Rd: 24.00 cm 5/32; Wd: 1.20-1.60 cm; H₁: 8.20 + x cm; throwing lines inside; eroded inside and outside; smoked on the rim. Others, Nile B₂, Rd: 27.00 cm 5/64, Rd: 28.00 cm 3/64.**No. 30: bakery tray** (Fig. 19:4), Inv. No. C-1300 [048]Uncoated | Nile C₂ | W₁ | HRim and base fragment; everted direct rim. Rd: 24.00 cm 1/8; Bd: 21.00 cm 1/8; Wd: 1.70 cm; H₁: 4.60 cm. VI: 522; eroded. Another (only base), Bd: 20.00 cm 3/32.

No. 31: “pigeon pot” (Fig. 19:4), Inv. No. C-1300 [050]

Uncoated	Nile B ₂	W ₂	W
----------	---------------------	----------------	---

Base fragment. Bd: 4.00 cm 3/16; Wd: 1.00 cm; H₁: 5.50 + x cm; throwing lines inside; smoothed on the wheel.

Egyptian marls**Household ware****No. 32: jar, Inv. No. C-1300 [054]**

Uncoated	Marl F	W ₂	W
----------	--------	----------------	---

Base sherd; flat base. Bd: 9.00 cm 1/4; Wd: 0.50 cm; H₁: 1.90 + x cm; throwing lines inside; eroded.

No. 33: jar?, Inv. No. C-1300 [062]

Uncoated	Marl A ₄ + limestone	Ha ₂ + W ₂
----------	---------------------------------	----------------------------------

Handle fragment; loop handle. Hd: 1.70 x 1.00 cm; H₁: 5.70 + x cm; incised lines on the handle; smoothed on the wheel.

Body sherds, Nile B₂: 122.00 dm²; Nile C₂: 12.00 dm²; Nile C₂ c.: 60.00 dm².

b) North Sinai/South Palestine pottery**Household ware**

No. 34: amphora, II.TG 08, body sherds, 0.10 dm².

No. 35: amphora, II.TG 10, body sherds, 0.10 dm².

c) Imported pottery**Levantine fine ware****No. 36: jug (Fig. 19:4), Inv. No. P7009A (Drawing No. 0902)**

---	IV.TG 18	W ₂	---	ox.	3
-----	----------	----------------	-----	-----	---

Body sherd; insertion of the handle preserved. Md: ca. 16.00 cm; Wd: 0.50 cm; H₁: 4.00 + x cm. Decoration: a horizontally painted band (red). Eroded and smoked.

Levantine household ware

No. 37: amphora, IV; TG 05, body sherds, 0.10 dm².

No. 38: amphora, IV; TG 07, body sherds, 0.10 dm².

No. 39: amphora, IV; TG 18, body sherds, 0.30 dm².

No. 40: amphora, IV; TG 24, body sherds, 0.20 dm².

No. 41: amphora, IV; TG 29, body sherds, 1.50 dm².

No. 42: amphora, IV; TG 36, body sherds, 0.20 dm².

No. 43: amphora, IV.TG 51(= TD IV.19), body sherds, 0.60 dm².

No. 44: amphora, IV.TG 52(= TD IV.19 c.), body sherds, 0.20 dm².

No. 45: amphora, IV.TG 53 (= TD IV.09), body sherds, 0.70 dm².

No. 46: amphora, = TD IV.2, body sherds, 0.50 dm².

No. 47: amphora, = TD IV.21, body sherds, 0.50 dm².

Cypriote household ware

No. 48: amphora, VI.TG 04, body sherds, 0.10 dm².

No. 49: amphora, VI.TG 44, body sherds, 0.10 dm².

No. 50: amphora, VI.TG 49, body sherds, 0.20 dm².

Aegean fine ware**Black-on-Red II ware**

No. 51: juglet, Inv. No. P0785A (Drawing No. 0657)

RPMO	VII?TG.58 v. f.	Ha ₂	---	ox.	3
------	-----------------	-----------------	-----	-----	---

Handle fragment; oval in section, 1; single strap. Wd: 0.20 cm; Hd: 0.70 x 0.50 cm. Surface colour: 2.5YR 5/8 red slip. Break: 2.5YR 5/8 red. Decoration: two vertically painted lines along the handle, 3.5 mm wide, horizontally lines, 1-1.5 mm wide, and a line around the handle base, 2.5YR 2.5/2 very dusky red. Surface treatment: polished; low lustre.

II.- Finds

Personal object

No. 52: bead, Inv. No. F0369A. Faience. D: 0.30 cm; colour: white; destroyed. *Find No. 024.*

Objects of unknown use

No. 53: fragment of an object, Inv. No. F0374A. Faience. 0.80 x 1.00 x 0.80 cm; colour: Chart 1 for gley 5GY 7/1 light greenish grey. *Find No. 019.*

No. 54: fragment of an object (Fig. 19:4), Inv. No. F0446A (Drawing No. 0455). Fragmentary; bronze; melted. 1.20 x 7.90 x 0.50 cm; blade of a knife? *Find No. 021.*

Product

No. 55: slag, Inv. No. F0367A. *Find No. 025.*

No. 56: slag, Inv. No. F0674A.

L1217 (Fig. 20)

Pottery

a) Egyptian pottery

Nile silt clay

Household ware

No. 1: bowl (Fig. 20), Inv. No. C-1092 [002]

Uncoated	Nile B ₂	W ₂
----------	---------------------	----------------

Rim sherd; everted articulated interior rim, trimmed lip. Rd: 34.00 cm 1/16; Wd: 1.23 cm; H₁: 4.97 + x cm; smoothed on the wheel.

No. 2: jar (Fig. 20), Inv. No. C-1092 [001]

Uncoated	Nile B ₂	W ₂
----------	---------------------	----------------

Rim sherd; vertical direct rim. Rd: 10.00 cm 5/32; Wd: 0.67 cm; H₁: 4.13 + x cm. Throwing lines inside; smoothed on the wheel. Another, Rd: 6.00 cm 5/32.

No. 3: jar (Fig. 20), Inv. No. C-1092 [003]

Uncoated	Nile B ₂	W ₂
----------	---------------------	----------------

Rim sherd; everted articulated exterior rim, round lip. Rd: 16.00 cm 5/32; Wd: 0.93 cm; H₁: 7.30 + x cm. Throwing lines inside; smoothed on the wheel.

No. 4: jar, Inv. No. C-1092 [006]

Uncoated	Nile B ₂	Ha ₂
----------	---------------------	-----------------

Handle fragment; loop handle; Hd: 3.16 x 2.17 cm; oval in section; smoothed.

Egyptian marls

Household ware

No. 5: amphora, Inv. No. C-1092

Uncoated	Marl A ₄ c.	W ₂
----------	------------------------	----------------

Shoulder fragment; Wd: 0.77 cm; eroded.

Body sherds, Nile B₂: 50 dm².

b) North Sinai/South Palestine pottery

Household ware

No. 6: amphora, Inv. No. C-1092 [005]

Uncoated	II.TG 08	W ₂	W
----------	----------	----------------	---

Base fragment; rounded base; Wd: 0.52 cm; H₁: 1.37 + x cm. Throwing lines inside; smoothed on the wheel.

L1224 (Fig. 21)

I.- Pottery

a) Egyptian pottery

Nile silt clay

Fine ware

Egyptian painted ware

Black on uncoated ware

No. 1: jar? (Fig. 21:1), Inv. No. P1171A (Drawing No. 0521)

UncMO	Nile B ₁	Ha ₁	---	re.	2
-------	---------------------	-----------------	-----	-----	---

Body sherd. Wd: 1.00 cm; H₁: 6.00 + x cm. Surface colour: 2.5YR 5/4 reddish brown.

Break: 7.5YR 5/1 grey interior; 2.5YR 5/6 red exterior. Decoration: two obliquely painted bands framed by two horizontal, 4-8 mm wide; above a pattern of zigzag bands, 3 mm wide, 2.5YR 4/1 dark reddish grey. Surface treatment: smoothed.

Household ware

No. 2: bowl, Inv. No. C-1339 (2)

Uncoated	Nile C ₁	W ₂
----------	---------------------	----------------

Rim sherd; everted direct rim. Rd: 22.00? cm 1/8; eroded.

No. 3: bowl, Inv. No. C-1339 (2)

Uncoated	Nile C ₁	W ₂
----------	---------------------	----------------

Rim sherd; everted articulated exterior rim. Rd: 24.00 cm 5/32; eroded.

No. 4: jar (Fig. 21:1), Inv. No. C-1339 (2) [003]

Uncoated	Nile B ₂	W ₂
----------	---------------------	----------------

Rim sherd; inverted direct rim. Rd: 10.00 cm 3/32; Wd: 0.70 cm; H₁: 4.60 + x cm; throwing lines inside; eroded. Others, Rd: 10.00 cm 1/8, Rd: 12.00 cm 1/8. Nile C₁, Rd: 8.00 cm 3/16, Rd: 10.00 cm 3/8.

No. 5: jar (Fig. 21:1), Inv. No. C-1339 (2) [007]

Uncoated	Nile B ₂	W ₂
----------	---------------------	----------------

Rim sherd; inverted articulated exterior rim. Rd: 12.00 cm 3/32; Wd: 0.50 cm; H₁: 2.90 + x cm; throwing lines inside; eroded.

No. 6: jar (Fig. 21:1), Inv. No. C-1339 (2) [005]

Uncoated	Nile C ₁	W ₂
----------	---------------------	----------------

Rim sherd; vertical direct rim, Rd: 8.00 cm 5/32; Wd: 0.50 cm; H₁: 2.10 + x cm; throwing lines inside; eroded.

No. 7: jar, Inv. No. C-1339 (2) [010]

Uncoated	Nile C ₁	W ₂
----------	---------------------	----------------

Neck fragment. Nd: 10.00cm 1/8; Wd: 0.80 cm; H₁: 4.50 + x cm; throwing lines inside; smoothed on the wheel.

Pottery with special functions

No. 8: bakery tray (Fig. 21:1), Inv. No. C-1339 (2) [012]

Uncoated	Nile C ₂	W ₁	Ha
----------	---------------------	----------------	----

Rim and base fragment; everted direct rim. Rd: 22.00 cm 3/32; Bd: 20.00 cm 5/32; Wd: 1.6 cm; H₁: 5.00 cm. VI: 400. Throwing lines inside; eroded. Another (only rim), Rd: 20.00 cm 3/32.

Egyptian marls

Household ware

No. 9: deep bowl (Fig. 21:1), Inv. No. P1170A (Drawing No. 0638)

Uncoated	Marl A ₄	W ₂	base finished on the wheel	ox.	3
----------	---------------------	----------------	----------------------------	-----	---

Incomplete; 3 fragments; direct rim, pointed base. Rd: 12.00 cm 1/4 ; Wd: 0.30 cm; H₁: 3.40 + x cm + 1.30 cm. Surface colour: 10YR 7/3 very pale brown (self slip). Break: 10YR 7/4 very pale brown. Technical details: rilling lines inside and outside. Surface treatment: smoothed on the wheel.

No. 10: juglet, Inv. No. C-9052 [001]

Uncoated	Marl A ₄	Ha ₂
----------	---------------------	-----------------

Handle fragmentary; loop handle. Hd: 1.75 x 1.00 cm; smoothed.

No. 11: amphora (Fig. 21:2), Inv. No. P1169A (Drawing No. 0636)

Uncoated	Marl A ₄	W ₂ + Ha ₂	---	ox.	3
----------	---------------------	----------------------------------	-----	-----	---

Shoulder and handle fragments. Md: 24.00 + x cm; Wd: 0.50 cm; H₁: 2.50 + 7.00 + x cm; Hd: 1.80 x 1.40 cm. Surface colour: 2.5Y 6/2 light brownish grey (self slip). Break: 10YR 6/2 light brownish grey exterior; 2.5YR 4/4 reddish brown interior. Technical details: throwing lines inside; ribbed surface; applied handle. Surface treatment: smoothed.

No. 12: amphora Inv. No. C-1339 (2)

Uncoated	Marl F	Ha ₂
----------	--------	-----------------

Handle fragment; loop handle. Hd: 3.00 x 2.90 cm.

b) North Sinai/South Palestine pottery

No. 13: amphora, II.TG 08, body sherds: 0.10 dm².

c) Imported pottery

Levantine household ware

No. 14: amphora, IV.TG 07, body sherds, 0.10 dm².

No. 15: amphora, IV.TG 24, body sherds, 0.10 dm².

No. 16: amphora, IV.TG 29, body sherds, 0.10 dm².

No. 17: amphora, IV.TG 51 (=TD IV.19), body sherds, 0.10 dm².

No. 18: amphora, =TD IV.08, body sherds, 0.20 dm².

Cypriote household ware

No. 19: amphora, VI.TG 04, body sherds, 0.10 dm².

II.-Finds

Tool

No. 20: undifferentiated tool (Fig. 21:2), Inv. No. F0946A (Drawing No. 0945). Diorite; 1.40-3.20 cm (wide) x 1.00-1.30 cm (thick); polisher as secondary use; part of a palette for cosmetics?

L1225 (Fig. 22)

I.-Pottery

a) Egyptian pottery

Nile silt clay

Household ware

No. 1: bowl (Fig. 22:1), Inv. No. C-1337 (2) [005]

Uncoated	Nile B ₂	W ₂
----------	---------------------	----------------

Rim sherd; incurved walls; inverted direct rim. Rd: 16.00 cm 5/32; Wd: 0.65 cm; H₁: 4.50 + x cm; smoothed on the wheel.

No. 2: jar (Fig. 22:1), Inv. No. C-1337 (2) [006]

Uncoated	Nile B ₂	W ₂
----------	---------------------	----------------

Rim sherd; vertical direct rim. Rd: 10.00 cm 1/8; Wd: 0.40 cm; H₁: 2.50 + x cm; throwing lines inside; smoothed on the wheel; eroded.

No. 3: jar (Fig. 22:1), Inv. No. C-1337 (2) [007]

Uncoated	Nile B ₂	W ₂
----------	---------------------	----------------

Rim sherd; everted direct rim. Rd: 10.00 cm 3/16; Wd: 0.70 cm; H₁: 3.00 + x cm; throwing lines inside; smoothed on the wheel; eroded.

No. 4: long necked jar (Fig. 22:1), Inv. No. C-1337 (2) [003]

Uncoated	Nile B ₂	W ₁
----------	---------------------	----------------

Rim sherd; everted direct rim, flaring inside. Rd: 12.00 cm 1/8; Wd: 0.70 cm; H₁: 7.35 + x cm; throwing lines inside; smoothed on the wheel; eroded.

No. 5: long necked jar (Fig. 22:1), Inv. No. C-1337 (2) [004]

Uncoated	Nile B ₂	W ₂
----------	---------------------	----------------

Rim sherd; everted articulated exterior rim. Rd: 8.00 cm 1/4; Wd: 0.50 cm; H₁: 5.10 + x cm; throwing lines inside; smoothed on the wheel.

No. 6: jar, Inv. No. P1400A (Drawing No. 0715)

Uncoated	Nile C ₂	W ₁ + Ha ₂	---	ox.	2
----------	---------------------	----------------------------------	-----	-----	---

Wall fragment and handle; slender type; oval in section; 1 [2]; single strap. Md: 17.00 cm ¼; Wd: 1.75 cm; H₁: 18.00 + x cm; Hd: 2.90 x 2.10 cm. Surface colour: 10R 4/6 red slip. Break: 10R 4/6 red. Technical details: throwing lines inside. Surface treatment: smoothed.

No. 7: storage jar (Fig. 22:1), Inv. No. C-1337 (2) [008]

Uncoated	Nile B ₂	W ₂
----------	---------------------	----------------

Rim sherd; inverted direct rim, folded lip. Rd: 24.00 cm 5/32; Wd: 1.00 cm; H₁: 4.00 + x cm; throwing lines inside; eroded.

No. 8: storage jar (Fig. 22:1), Inv. No. C-1337 (2) [009]

Uncoated	Nile B ₂	W ₂
----------	---------------------	----------------

Rim sherd; everted articulated interior and exterior rim, trimmed lip. Rd: 20.00 cm 3/32; Wd: 0.90 cm; H₁: 4.40 + x cm; smoothed on the wheel; eroded outside and on the rim.

No. 9: storage jar? Inv. No. C-1337 (2) [013bis]

Uncoated	Nile C ₁	W ₂	base finished on the wheel
----------	---------------------	----------------	----------------------------

Base fragment; ring base. Bd: 12.00 cm 3/16; Wd: 1.50 cm; H₁: 5.60 + x cm; throwing lines inside; smoothed on the wheel; finger prints inside; eroded.

Egyptian Pottery with special functions

No. 10: lid (Fig. 22:1), Inv. No. C-1337 (2) [014]

Uncoated	Nile C ₁	W ₂	W
----------	---------------------	----------------	---

Rim sherd; everted direct rim. Rd: 22.00 cm 1/16; Wd: 0.16 cm; H₁: 3.10 + x cm; throwing

No. 11: bakery tray (Fig. 22:2), Inv. No. C-1337 (2) [011]

Uncoated	Nile C ₂	W ₁
----------	---------------------	----------------

Rim sherd; everted direct rim. Rd: 42.00 cm 1/8; Wd: 1.65 cm; H₁: 4.10 + x cm; throwing lines inside; eroded. Others, Rd: 20.00 cm 1/8, Rd: 26.00 cm 5/32, Rd: 42.00 cm 1/8.

No. 12: "pigeon pot" (Fig. 22:2), Inv. No. C-1337 (2) [012bis]

Uncoated	Nile B ₂	W ₂	W
----------	---------------------	----------------	---

Base fragment; Bd: 4.00 cm 1/4; Wd: 1.30 cm; H₁: 5.50 + x cm; throwing lines inside; smoothed on the wheel; eroded.

b) North Sinai/South Palestine pottery

Household ware

No. 13: amphora, II?; TG 59, body sherds, 0.10 dm².

c) Imported pottery

Levantine household ware

No. 14: amphora, IV.TG 52(= TD IV.19 coarse), body sherds, 0.20 dm².

No. 15: amphora, IV.TG 53 (= TD IV.09), body sherds, 0.10 dm².

No. 16: amphora, IV.TG 61, body sherd, 0.10 dm².

Cypriote household ware

No. 17: amphora, VI.TG 40, body sherds, 0.10 dm².

II.- Finds

Personal objects

No. 18: pendant (Plate 1), Inv. No. F0661 (Drawing No. 0440). Complete; agate. 1.75 x 1.02 x 0.42 cm. Perforation: 1.3 mm. SCA No. 4034. Find No. 016.

No. 19: bead (Fig. 22:2), Inv. No. F0647 (Drawing No. 0459). Complete; faience; moulded. 0.34 x 0.22 cm; cylindrical shape; perforation: 0.9 mm. SCA No. 4034. Find No. 015.

Stone vessel

No. 20: bowl, Inv. No. F0733A (Drawing No. 0503). Fragmentary; alabaster. Rd: ca. 9.00 cm 3/16; H₁: 3.50 cm. Bowl with direct rim and round base. Function: cosmetic pot?. Find No. 017.

L1228 = L1237 (Fig. 23)

I.- Pottery

Egyptian pottery

Nile silt clay

Fine ware

Egyptian painted ware***Bichrome ware*****No. 1: deep bowl** (Fig. 23:1), Inv. No. P1122A + P1134A (Drawing No. 0646)WPBI | Nile valley clay | W₂ | --- | ox. | 2-3

Rim and body fragments; flaring sided, everted direct. Rd: 14.00 cm 1/8; Wd: 0.25 cm; H₁: 11.50 + x cm. Surface colour: 5YR 7/4 pink slip. Break: 5YR 6/4 light red - 5/8 yellowish red. Technical details: made in parts; fine ridges inside. Decoration: a geometric pattern painted on the exterior, 10R 4/8 red and 10R 4/1 dark reddish grey. Surface treatment: polished, low lustre. *Find No. 031.*

Household ware**No. 2: jar** (Fig. 23:1), Inv. No. P7040A (Drawing No. 0913)Uncoated | Nile B₂ | W₂ | W | ox. | 2

Base (R₃) fragment. Md: 16.20 + x cm; Bd: 10.60 cm 1/2; Wd: 0.85 cm; H₁: 6.80 + x cm. Surface colour: 2.5YR 5/4 reddish brown. Break: 2.5YR 5/6 red. Technical details: made in parts; throwing lines inside; finger prints inside the base. Surface treatment: smoothed on the wheel.

No. 3: jar (Fig. 23:1), Inv. No. C-1323 [010]Uncoated | Nile B₂ | W₂

Rim sherd; inverted articulated interior rim, round lip. Rd: 12.00 cm 3/16; Wd: 0.50 cm; H₁: 4.80 + x cm; throwing lines inside; smoothed on the wheel; eroded.

No. 4: jar (Fig. 23:1), Inv. No. C-1323 [001]Uncoated | Nile B₂ | W₂

Rim sherd; inverted articulated interior rim, trimmed lip. Rd: 18.00 cm 5/32; Wd: 0.90 cm; H₁: 7.00 + x cm; throwing lines inside; smoothed on the wheel; eroded.

No. 5: jar (Fig. 23:1), Inv. No. C-1323 [009]Uncoated | Nile B₂ | W₂

Rim sherd; vertical direct rim. Rd: 10.00 cm 1/4; Wd: 0.60 cm; H₁: 5.30 + x cm; throwing lines inside; smoothed on the wheel; smoked outside. Others, Rd: 10.00 cm 1/8, Rd: 12.00 cm 1/2.

No. 6: jar, Inv. No. C-1323 [005]Uncoated | Nile B₂ | W₂

Rim sherd; everted articulated exterior rim, rolled lip. Rd: 18.00 cm 1/8; throwing lines inside; smoothed on the wheel; eroded.

No. 7: jar, Inv. No. C-1323 [018]Uncoated | Nile B₂ | Ha₂

Handle fragment; loop handle. Hd: 0.75 x 1.00 cm; oval in section; 1; single strap; eroded.

No. 8: storage jar, Inv. No. C-1323 [012]Uncoated | Nile B₂ | W₂

Rim sherd; inverted articulated interior rim, folded lip. Rd: 20.00 cm 5/32; throwing lines inside; smoothed on the wheel; very eroded.

No. 9: storage jar, Inv. No. P1204A (Drawing No. 0927)Uncoated | Nile B₂ | W₂ | W | ox. | 2

Base and body fragment; round base. Md: 29.00 + x cm; Wd: 1.10 cm; H₁: 21.00 + x cm.

Surface colour: 5YR 5/4 reddish brown. Break: 5YR 5/4 reddish brown. Technical details: made in parts; throwing lines inside. Surface treatment: smoothed on the wheel. *Find No. 007.*

Pottery with special functions

No. 10: lid (Fig. 23:2), Inv. No. P1257A (Drawing No. 0915)

Uncoated	Nile B ₂	W ₂	W	ox.	2
----------	---------------------	----------------	---	-----	---

Complete, fragmentary; mended; 3/4 of the lid; exterior lip. Rd: 27.00 cm; Wd: 0.80 cm; H₁: 9.30 cm. VI: 290. Surface colour: 5YR 5/4 reddish brown. Break: 5YR 4/4 reddish brown. Technical details: throwing lines inside; made in parts; slightly undulated walls on the exterior. Surface treatment: smoothed on the wheel. Smoked inside on the rim and body, and on the body outside. Another, Rd: 28.00 cm 1/8.

No. 11: bakery tray, Inv. No. C-1323 [008]

Uncoated	Nile C ₂	W ₂	Ha
----------	---------------------	----------------	----

Rim and base fragment; flat base, everted direct rim. Rd: 24.00 cm 3/32; Bd: 20.00 cm; Wd: 0.90 cm; eroded. Another, Rd: 24.00 cm 3/32.

No. 12: "pigeon pot" (Fig. 23:2), Inv. No. C-1323 [016]

Uncoated	Nile B ₂	W ₂
----------	---------------------	----------------

Base fragment. Bd: 3.00 cm 1/2; Wd: 0.95 cm; H₁: 4.90 + x cm; throwing lines inside; smoothed on the wheel; eroded and smoked inside.

Egyptian marls

Household ware

No. 13: amphora (Fig. 23:2), Inv. No. P7046A (Drawing No. 0923)

Uncoated	Marl F	W ₂ + Ha ₂	---	ox.	3
----------	--------	----------------------------------	-----	-----	---

Incomplete, fragmentary; no rim and base preserved. Md: 28.00 cm; Wd: 0.90 cm; H₁: 48.50 + x cm; H₂: 16.50 + x cm; Hd: 2.90 x 2.10 cm. Surface colour: 5YR 7/4-7.5YR 7/4 pink self slip. Break: 10YR 7/3 very pale brown. Technical details: made in parts; applied handle. Surface treatment: smoothed on the wheel. *Find No. 033.*

Body sherds, Nile B₂: 32.00 dm²; Nile C₂: 3.00 dm²; Marl A₄ + limestone.

b) Imported pottery

Levantine household ware

No. 14: amphora, IV.TG 29, body sherds.

No. 15: amphora, IV.TG 51 (=TD IV.19), body sherds.

No. 16: amphora, IV.TG 52 (=TD IV.19 c.), body sherds.

II.- Finds

Suspended weight

No. 17: net weight (Fig. 23:2), Inv. No. F0583A (Drawing No. 1074). Limestone. Weight: 166.00 gr. 6.90 x 4.30 x 4.40 cm. Function: fishing.

No. 18: net weight (Fig. 23:2), Inv. No. F0901A (before Inv. No. F0901B. Drawing No. 1077). Limestone. Weight: 153.00 gr. 7.70 x 4.30 x 3.90 cm. Secondary use. *Find No. 030.*

Object of unknown use

No. 19: fragments (2) of an object, Inv. No. F0761A; bronze. *Find No. 032.*

L1229 (Fig. 24)**I.- Pottery****Egyptian pottery****Nile silt clay****Household ware****No. 1: bowl (Fig. 24), Inv. No. C-1328 [001]**Uncoated Nile B₂ W₂Rim sherd; slightly carinated bowl, everted articulated simmetrical rim, flat lip. Rd: 20.00 cm 1/16; Wd: 1.00 cm; H₁: 3.55 + x cm; smoothed on the wheel; smoked.**No. 2: jar (Fig. 24), Inv. No. C-1328 (2) [002]**Uncoated Nile B₂ W₂Rim sherd; slightly inverted direct rim. Rd: 10.00 cm 3/16; Wd: 0.45 cm; H₁: 4.80 + x cm; throwing lines inside; smoothed on the wheel; eroded.**No. 3: jar (Fig. 24), Inv. No. C-1328 (2) [001]**Uncoated Nile B₂ W₂Rim sherd; slightly inverted articulated interior rim, round lip. Rd: 10.00 cm 3/32; Wd: 0.60 cm; H₁: 5.30 + x cm; throwing lines inside; smoothed on the wheel; eroded.**No. 4: jar (Fig. 24), Inv. No. C-1328 [002]**Uncoated Nile B₂ W₂Rim sherd; vertical direct rim. Rd: 8.00 cm 3/16; Wd: 0.50 cm; H₁: 2.13 + x cm; throwing lines inside; smoothed on the wheel; eroded.**No. 5: storage jar, Inv. No. C-1328 (2)**Uncoated Nile B₂ W₂

Rim sherd; inverted articulated interior and exterior rim. Rd: 26.00 cm 3/32; eroded

Egyptian votive ware**No. 6: votive jar (Fig. 24), Inv. No. P0010A (Drawing No. 0932)**RP Nile B₂ W₂ --- re. 2-3Incomplete, fragmentary; no rim and base preserved. Nd: 1.05 cm; Md: 2.45 cm; Wd: 0.25 cm; H₁: 4.50 + x cm; H₃: 0.50 + x cm. Surface colour: 10R 4/3 weak red slip. Break: 5YR 5/4 reddish brown exterior zone (thin); 4/1 dark grey interior zones (thick). Technical details: made in parts. Surface treatment: polished, medium lustre. *Find No. 023.***Body sherds**, Nile B₂, Marl A₄, Marl F.**II.- Finds****Personal object****No. 7: bead (Fig. 24), Inv. No. F0625 (Drawing No. 0437).** Complete; faience; moulded. 0.66 x 0.39 cm; colour: blue. Cylindrical shape; perforation: 1.50 mm. SCA No. 4015. *Find No. 022.***L1230 (Fig. 25)****I.- Pottery****a) Egyptian pottery****Nile silt clay****Fine ware**

Egyptian painted ware***Black on Red slip ware*****No. 1: jug?**, Inv. No. P1142ARSMO | Nile B₂ | W₂ | --- | re. | 2-3

Body sherd; Wd: 0.40 cm. Surface colour: 10R 5/6 red slip. Break: 10R 5/6 red. Decoration: horizontally painted bands, 5YR 5/1 grey. Surface treatment: smoothed on the wheel.

Bichrome ware**No. 2: pilgrim flask** (Fig. 25), Inv. No. P1128A (Drawing No. 0630)RPBI | Nile E₂ | Ha₁ | --- | re. | 2-3

Body fragment; lentil shape. Wd: 0.35 cm; H₁: 6.10 + x cm. Surface colour: 2.5YR 5/4 reddish brown slip. Break: 2.5YR 3/1 dark reddish grey. Technical details: made in two halves which are then joined. Decoration: three concentric painted circles, 1-1.5 mm wide, with a black-black-red pattern (2.5YR 2.5/1 reddish black and 10R 4/4 weak red). Surface treatment: polished, low lustre.

Egyptian household ware**No. 3: bowl**, Inv. No. C-1341 [002]RS | Nile B₂ | W₂

Rim sherd; incurved walls, everted direct rim. Rd: 21.00 cm 1/16; Wd: 0.90 cm; H₁: 3.20 + x cm; red slipped; smoothed on the wheel. Others, uncoated, Rd: 15.00 cm 3/64, Rd: 28.00 cm 1/16, Rd: 36.00 cm 1/32.

No. 4: bowl or lid?, Inv. No. C-1341 [010]Uncoated | Nile B₂ | W₂

Rim sherd; everted articulated exterior rim, modelled lip. Rd: 26.00 cm 1/16; Wd: 0.65 cm; H₁: 1.00 + x cm; smoothed on the wheel.

No. 5: juglet, Inv. No. C-1341 [023]Uncoated | Nile B₂ | Ha₂

Handle fragment; loop handle. Hd: 1.60 x 0.90 cm; smoothed. Another, red slipped, Hd: 1.70 x 1.20 cm.

No. 6: jar, Inv. No. C-1341 [008]Uncoated | Nile B₂ | W₂

Rim sherd; inverted articulated interior and exterior rim, round lip. Rd: 16.00 cm 5/32; Wd: 0.50 cm; H₁: 3.60 + x cm. Throwing lines inside; smoothed on the wheel.

No. 7: jar, Inv. No. C-1341 [001]Uncoated | Nile B₂ | W₂

Rim sherd; vertical direct rim. Rd: 8.00 cm 1/8; Wd: 0.70 cm; H₁: 5.80 + x cm. Throwing lines inside; smoothed on the wheel. Others, Rd: 10.00 cm 3/8, Rd: 12.00 cm 3/32.

No. 8: jar, Inv. No. C-1341 [005]Uncoated | Nile B₂ | W₂

Rim sherd; vertical articulated interior and exterior rim, folded lip. Rd: 18.00 cm 3/32; Wd: 0.90 cm; H₁: 4.00 + x cm. Throwing lines inside; smoothed on the wheel.

No. 9: jar, Inv. No. C-1341 [007]Uncoated | Nile B₂ | W₂

Rim sherd; everted direct rim. Rd: 10.00 cm 5/32; Wd: 0.50 cm; H₁: 2.90 + x cm. Throwing lines inside; smoothed on the wheel. Others, Rd: 8.00 cm 3/32, Rd: 12.00 cm 1/32.

No. 10: storage jar, Inv. No. C-1341 [004]

Uncoated | Nile B₂ | W₂

Rim sherd; inverted articulated interior and exterior rim, modelled lip. Rd: 30.00 cm 1/16; Wd: 0.80 cm; H₁: 5.00 + x cm. Throwing lines inside; smoothed on the wheel.

No. 11: storage jar, Inv. No. C-1341 [003]

Uncoated | Nile B₂ | W₂

Rim sherd; inverted direct rim. Rd: 32.00 cm 1/16; Wd: 1.50 cm; H₁: 4.50 + x cm. Throwing lines inside; smoothed on the wheel. Another, Rd: 24.00 cm 1/16.

No. 12: storage jar, Inv. No. C-1341 [016]

Uncoated | Nile B₂ | W₂

Rim sherd; vertical direct rim. Rd: 22.00 cm 1/16; Wd: 0.80 cm; H₁: 2.80 + x cm. Throwing lines inside; smoothed on the wheel.

No. 13: amphora Inv. No. C-1341 [020], handle fragment; Nile B₂. Hd: 3.00 x 2.10 cm; eroded.

Pottery with special functions

No. 14: bakery tray, Inv. No. C-1341 [013]

Uncoated | Nile C₂ | W₁ | Ha

Complete, fragmentary; flat base, everted direct rim. Rd: 32.00 cm 3/32; Bd: --; Wd: 1.60 cm; H₁: 5.30 cm; VI: 604. Another (only base), Nile C₁, Bd: 20.00 cm 3/32.

No. 15: "pigeon pot", Inv. No. C-1341 [017]

Uncoated | Nile B₂ | W₂

Rim sherd; everted direct rim. Rd: 3.50 cm 1/32; Wd: 1.10 cm; H₁: 4.00 + x cm. Throwing lines inside; smoothed on the wheel; eroded.

Egyptian marls, household ware

No. 16: amphora, Inv. No. C-1341 [021], Marl F; Hd: 2.70 x 1.70 cm, smoothed.

Bodys sherds, Nile B₂/C₁, Marl A₄, Marl F, Marl F + limestone.

b) Imported pottery

Levantine household ware

No. 17: amphora, IV.TG 18, body sherds: 0.10 dm².

No. 18: amphora, IV.TG 24, body sherds: 0.10 dm².

No. 19: amphora, IV.TG 51 (=TD IV.19), body sherds: 0.20 dm².

No. 13: amphora, IV.TG 52 (=TD IV.19c.), body sherds: 0.20 dm².

No. 20: amphora, IV.TG 53 (=TD IV.09), body sherds: 0.30 dm².

II.- Finds

Personal objects

No. 21: bead, Inv. No. F0646A (Drawing No. 0463). Complete; faience; moulded. 0.43 x 0.28 cm; colour: Chart 1 for gley 5/10 Y greenish grey; cylindrical shape; perforation: 0.9

mm. *Find No. 018.*

No. 22: bead, Inv. No. F0927A (Drawing No. 0939). Bone; 1.20 x 0.40 cm; a raye vertebra used as a bead.

Grinding stone

No. 23: netherstone (Fig. 25), Inv. No. F0940A (Drawing No. 0944). Fragmentary; limestone. 9.70 x 6.00 x 1.40 cm. Characteristics: minimum width: 25 mm. Comments: marks are doubtful, since it is a soft stone. Wear marks: longitudinal wear marks. Surfaces: 1. Surface configuration: concave. Stroke: crosswise.

L1236 (Fig. 26)

I.- Pottery

Egyptian pottery

Nile silt clay

Fine ware

Egyptian painted ware

Bichrome ware

No. 1: pilgrim flask, Inv. No. P1129A (Drawing No. 0631)

BPBI	Nile B ₂	Ha ₂ + W ₂	---	ox.	2
------	---------------------	----------------------------------	-----	-----	---

Body sherd. Wd: 0.30 cm; H₁: 1.80 + x cm. Surface colour: 5YR 7/4 pink - 6/4 light reddish brown slip. Break: 5YR 5/3 reddish brown. Decoration: concentric painted bands, 2 mm wide, black (10R 4/1 dark reddish grey) and red (10R 5/8). Surface treatment: polished, low lustre.

Household ware

No. 2: bowl (Fig. 26), Inv. No. C-1317 [010]

Uncoated	Nile B ₂	W ₂
----------	---------------------	----------------

Rim sherd; everted direct rim. Rd: 28.00 cm 1/16; Wd: 0.60cm; H₁: 4.20 + x cm; smoothed on the wheel; eroded outside; smoked inside (used as a cover). Another, Rd: 30.00 cm 1/8.

No. 3: bowl (Fig. 26), Inv. No. C-1317 [006]

RS	Nile B ₂	W ₂
----	---------------------	----------------

Rim sherd; inverted articulated exterior rim, trimmed lip. Rd: 20.00 cm 1/16; Wd: 0.40 cm; H₁: 1.70 + x cm; red slipped; a groove below the rim; smoothed on the wheel.

No. 4: jug, Inv. No. C-1317 [011]

Uncoated	Nile B ₂	W ₂
----------	---------------------	----------------

Rim and handle fragment; neck to rim attached vertical loop handle; everted direct rim. Rd: 10.00 cm 5/32; Hd: 3.00 x 1.50 cm; 1; single strap. Smoothed.

No. 5: jar (Fig. 26), Inv. No. C-1317 [009]

Uncoated	Nile B ₂	W ₂
----------	---------------------	----------------

Rim sherd; everted articulated exterior rim. Rd: 16.00 cm 1/8; Wd: 0.70 cm; H₁: 2.80 + x cm. Throwing lines inside; smoothed on the wheel.

No. 6: jar, Inv. No. C-1317 [013]

Uncoated	Nile B ₂	Ha ₂ + W ₂
----------	---------------------	----------------------------------

Handle fragment; body to body attached vertical loop handle. H₁: 5.62 + x cm; Hd: 3.19 x 1.88 cm; smoothed.

No. 7: jar, Inv. No. C-1317 [014]

Uncoated	Nile B ₂	Ha ₂ + W ₂
----------	---------------------	----------------------------------

Handle fragment; attached horizontal loop handle. H₁: 3.55 + x cm; Hd: 1.82 x 1.33 cm; 1; single strap.

No. 8: storage jar (Fig. 26), Inv. No. C-1317 [001]

Uncoated	Nile B ₂	W ₂
----------	---------------------	----------------

Rim sherd; inverted direct rim. Rd: 22.00 cm 3/32; Wd: 0.80 cm; H₁: 7.30 + x cm. Throwing lines inside; smoothed on the wheel; eroded.

No. 9: storage jar (Fig. 26), Inv. No. C-1317 [004]

Uncoated	Nile B ₂	W ₂
----------	---------------------	----------------

Rim sherd; everted direct rim. Rd: 26.00 cm 1/16; Wd: 0.70 cm; H₁: 7.50 + x cm. Throwing lines inside; smoothed on the wheel; a groove below the rim.

No. 10: handle fragment; Inv. No. C-1317, Nile B₂, Hd: 4.90 x 2.00 cm; smoothed.

Egyptian marls

Household ware

No. 11: jar (Fig. 26), Inv. No. C-1317 [005]

Uncoated	Marl F	W ₂
----------	--------	----------------

Rim sherd; vertical direct rim. Rd: 8.00 cm 1/8; Wd: 0.50 cm, H₁: 3.60 + x cm. Throwing lines inside; smoothed on the wheel; eroded.

Body sherds, Nile B₂: 40.00 dm²; Nile C₂ c.: 1.00 dm²; Marl A₄ + limestone, Marl F, Marl F + ochre.

b) Imported pottery

Levantine household ware

No. 12: amphora, Inv. No. C-1317, IV.TG 01, body sherds.

No. 13: amphora, Inv. No. C-1317, IV.TG 51 (=TD IV.09), body sherds.

No. 14: amphora, Inv. No. C-1317, IV.TG 61, body sherds.

L1400 (Fig. 27)

I.- Pottery

Egyptian pottery

Nile silt clay

Egyptian fine ware

No. 1: goblet (Fig. 27:1), Inv. No. P7023A (Drawing No. 0906)

RS	Nile B ₂	W ₂	W	ox.	2
----	---------------------	----------------	---	-----	---

Foot; tall foot. Fd: ca. 4.00 cm 1/1; Wd: 0.75 cm; H₁: 3.80 + x cm; H₄: 3.30 cm. Surface colour: 10R 5/6 red slip. Break: 2.5YR 5/8 red. Surface treatment: smoothed on the wheel.

Household ware

No. 2: bowl (Fig. 27:1), Inv. No. C-1301 (3) [001]

Uncoated	Nile B ₂	W ₂
----------	---------------------	----------------

Rim sherd; incurved walls, inverted articulated interior rim, flat lip. Rd: 20.00 cm 1/8; H₁: 5.34 + x cm; smoothed on the wheel; eroded.

No. 3: bowl (Fig. 27:1), Inv. No. C-1301 (3) [003bis]

Uncoated	Nile B ₂	W ₂
----------	---------------------	----------------

Rim sherd; everted direct rim. Rd: 20.00 cm $\frac{3}{32}$; Wd: 0.50 cm; H₁: 4.70 + x cm; smoothed on the wheel.

No. 4: bowl (Fig. 27:1), Inv. No. C-1301 (3) [004bis]

Uncoated	Nile B ₂	W ₂
----------	---------------------	----------------

Rim sherd; carinated bowl; everted direct rim. Rd: 18.00 cm $\frac{1}{16}$; Wd: 0.75 cm; H₁: 3.40 + x cm; smoothed on the wheel.

No. 5: bowl, Inv. No. C-1301 (1) [007]

Uncoated	Nile B ₂	W ₂
----------	---------------------	----------------

Base fragment; round base. H₁: 2.70 + x cm. Throwing lines inside; smoothed on the wheel.

No. 6: pot (Fig. 27:1), Inv. No. P1154A (Drawing No. 0528)

Uncoated	Nile B ₂	W ₂	W	ox.	2
----------	---------------------	----------------	---	-----	---

Incomplete, fragmentary; mended; round base. Nd: 3.30 cm; Md: 5.50 cm; Wd: 0.30 cm; H₁: 6.10 + x cm; H₂: 4.80 cm. Surface colour: 2.5YR 4/4 reddish brown. Break: 5YR 5/3 reddish brown. Technical details: throwing lines inside; irregular shape. Surface treatment: smoothed on the wheel.

No. 7: jar (Fig. 27:1), Inv. No. C-1301 (3) [003]

Uncoated	Nile B ₂	W ₂
----------	---------------------	----------------

Rim sherd; inverted direct rim. Rd: 12.00 cm $\frac{3}{32}$; Wd: 0.80 cm, H₁: 4.00 + x cm. Throwing lines inside; smoothed on the wheel; eroded. Others, Rd: 8.00 cm $\frac{1}{4}$, Rd: 10.00 cm $\frac{3}{32}$.

No. 8: jar (Fig. 27:1), Inv. No. C-1301 (3) [007]

Uncoated	Nile B ₂	W ₂
----------	---------------------	----------------

Rim sherd; vertical direct rim. Rd: 8.00 cm $\frac{1}{16}$; Wd: 0.30 cm; H₁: 2.50 + x cm. Throwing lines inside; smoothed on the wheel; eroded. Another, Rd: 10.00 cm $\frac{1}{16}$.

No. 9: jar (Fig. 27:2), Inv. No. C-1301 (1) [005]

Uncoated	Nile B ₂	W ₂
----------	---------------------	----------------

Rim sherd; vertical articulated exterior rim, folded lip. Rd: 18.00 cm $\frac{3}{32}$; Wd: 0.77 cm; H₁: 3.00 + x cm. Throwing lines inside; smoothed on the wheel.

No. 10: jar (Fig. 27:2), Inv. No. C-1301 (1) [003]

Uncoated	Nile B ₂	W ₂
----------	---------------------	----------------

Rim sherd; everted direct rim. Rd: 9.00 cm $\frac{1}{8}$; Wd: 0.60 cm; H₁: 4.66 + x cm. Throwing lines inside; smoothed on the wheel; salt incrustated. Others, Rd: 8.00 cm $\frac{1}{8}$, Rd: 10.00 cm $\frac{5}{32}$, Rd: 12.00 cm $\frac{3}{16}$.

No. 11: storage jar (Fig. 27:2), Inv. No. C-1301 (1) [001]

Uncoated	Nile B ₂	W ₂
----------	---------------------	----------------

Rim sherd; inverted articulated exterior rim, modelled lip. Rd: 20.00 cm $\frac{3}{16}$; Wd: 0.93 cm; H₁: 5.88 + x cm. Throwing lines inside; smoothed on the wheel; salt incrustated outside.

No. 12: handle fragments. Nile B₂, Hd: 1.90 x 2.52 cm, Hd: 2.94 x 2.00 cm, Hd: 3.80 x 2.32 cm.

Pottery with special functions**No. 13: bakery tray** (Fig. 27:2), Inv. No. C-1301 [005]Uncoated Nile C₂ W₁ HaRim and base fragment; flat base, everted direct rim. Rd: 18.00 cm 1/32; Bd: 20.00 cm 3/16; H₁: 4.00 cm. Another (rim), Rd: 20.00 cm 1/16.**No. 14: tray**, Inv. No. C-1301 (2) [008]Uncoated Nile C₂ Ha₁Fragment; H₁: 3.50 cm; eroded.**Body sherds**, Nile B₂, Marl A₄, Marl F.**b) Imported pottery****Levantine household ware****No. 15: amphora**, Inv. No. C-1301, IV.TG 53 (=TD IV.09), body sherds.**Aegean fine ware****Black-on-Red****No. 16: juglet**, Inv. No. P2038A (Drawing No. 0704)RPMO VII.TG 39 W₂ W med. 3Base and body fragment; flat base. Md: 6.00 cm 3/16; Bd: 3.00 cm 1/4; Wd: 0.30 cm; H₁: 3.20 + x cm. Surface colour: 10R 6/8 light red slip. Break: 10R 6/1 reddish grey core; 10R 6/8 light red oxidation zones. Surface treatment: polished, low lustre.**No. 17: juglet** (Fig. 27:2), Inv. No. P2017A (Drawing No. 0448)RPMO VII.TG 39 Ha₂ --- ox. 3

Handle fragment. Hd: 0.50 x 0.80 cm. Surface colour: 2.5YR 4/8 red. Break: 2.5YR 6/8 light red. Decoration: two painted lines, 4 mm wide, 2.5YR 3/1 dark reddish grey. Surface treatment: polished, low lustre.

II.- Finds**Religion****No. 18: wdjat eye** (Fig. 27:2), Inv. No. F0604 (Drawing No. 0446). Complete; faience; moulded. 2.9 x 2.25 x 0.84 cm; colour: 10YR 7/2 light grey; rests of colour Chart 1 for gley 8/5G light grey. Perforation: 0.19 mm. SCA No. 4027. *Find No. 001.***L1404 (Fig. 28)****I.- Pottery****a) Egyptian pottery****Nile silt clay****Household ware****No. 1: bowl**, Inv. No. C-1335 [004]Uncoated Nile B₂ W₂

Rim sherd; eroded.

No. 2: jar (Fig. 28), Inv. No. C-1335 [002]Uncoated Nile C₂ W₂Rim sherd; vertical direct rim. Rd: 10.00 cm 1/8; Wd: 0.65 cm; H₁: 5.90 + x cm. Throwing lines inside; smoothed on the wheel.

No. 3: jar, Inv. No. C-1335 [003]

Uncoated	Nile B ₂	W ₂
----------	---------------------	----------------

Rim sherd; eroded.

No. 4: storage jar (Fig. 28), Inv. No. C-1335 [001]

Uncoated	Nile B ₂	W ₂
----------	---------------------	----------------

Rim sherd; straight sided walls, vertical articulated exterior rim, trimmed lip. Rd: 22.00 cm 1/8; Wd: 0.77 cm; H₁: 6.15 + x cm. Throwing lines inside; smoothed on the wheel.

Pottery with special functions

No. 5: bakery tray (Fig. 28), Inv. No. C-1335 [006]

Uncoated	Nile C ₂	W ₁	Ha
----------	---------------------	----------------	----

Rim and base fragment; flat base, everted direct rim. Rd: 28.00 cm 1/8; Bd: 22.00 cm 1/8; Wd: 2.00 cm; H₁: 5.80 cm; VI: 483. Smoothed.

Body sherds, Nile B₂, 10.00 dm²; Nile C₂ c.: 1 dm².

b) North Sinai/South Palestine pottery

Household ware

No. 6: amphora, Inv. No. C-1335 [005]

Uncoated	II.TG 08	W ₂
----------	----------	----------------

Rim sherd; inverted direct rim. Rd: 10.00 cm 1/8; Wd: 1.00 cm; H₁: 3.25 + x cm. Throwing lines inside; smoothed on the wheel.

No. 7: amphora, II.TG 09, body sherds, 0.10 dm².

No. 8: amphora, II.TG 10, body sherds, 0.10 dm².

c) Imported pottery

Levantine household ware

No. 9: amphora, IV.TG 51 (=TD IV.19), body sherds, 0.10 dm².

No. 10: amphora, IV.TG 53 (=TD IV.09), body sherds, 0.10 dm².

I.- Finds

Product

No. 11: slag, Inv. No. F0775A. *Find No. 001.*

L1406 (Fig. 29)

I.- Pottery

a) Egyptian pottery

Nile silt clay

Fine ware

Egyptian painted ware

Black on red slip ware

No. 1: juglet (Fig. 29:1), Inv. No. P1133A (Drawing No. 0524)

RSBI	Nile B ₂ s.	W ₂	---	ox.	2
------	------------------------	----------------	-----	-----	---

Body sherd. Md: 12.00 + x cm; Wd: 0.4 cm; H₁: 2.10 + x cm. Surface colour: 5YR 6/4-6/3 light reddish brown slip Break: 5YR 5/3 reddish brown. Technical details: throwing lines inside; smoothed on the wheel. Decoration: horizontally painted bands, 10YR 4/4 weak red and 5/1 reddish grey. Surface treatment: smoothed on the wheel.

Household ware**No. 2: bowl (Fig. 29:1), Inv. No. C-1302 (2) [008]**Uncoated Nile B₂ W₂

Rim sherd; carinated walls, inverted incurved rim. Rd: 20.00 cm 1/32; Wd: 0.70 cm; H₁: 3.30 + x cm; smoothed on the wheel.

No. 3: bowl (Fig. 29:1), Inv. No. C-1302 (2) [012]Uncoated Nile B₂ W₂

Rim sherd; everted direct rim. Rd: 22.00 cm 1/8; Wd: 0.67 cm; H₁: 3.00 + x cm; smoothed on the wheel. Others, Rd: 18.00 cm 3/32, Rd: 20.00 cm 1/8, Rd: 24.00 cm 1/8, Rd: 26.00 cm 1/32, Rd: 28.00 cm 1/8.

No. 4: bowl (Fig. 29:1), Inv. No. C-1302 (2) [011]Uncoated Nile B₂ W₂

Rim sherd; everted articulated exterior rim. Rd: 24.00 cm 3/16; Wd: 0.90 cm; H₁: 2.50 + x cm; smoothed on the wheel. Another, Rd: 16.00 cm 1/32.

No. 5: globular jar (Fig. 29:1), Inv. No. C-1302 (2) [004]Uncoated Nile B₂ W₂

Rim sherd; everted direct rim. Rd: 16.00 cm 1/8; Wd: 1.00 cm; H₁: 4.50 + x cm; throwing lines inside; smoothed on the wheel.

No. 6: jar (Fig. 29:1), Inv. No. C-1302 (2) [042]Uncoated Nile B₂ W₂

Rim sherd; inverted direct rim. Rd: 12.00 cm 3/16; Wd: 0.65 cm; H₁: 2.50 + x cm; throwing lines inside; smoothed on the wheel.

No. 7: jar (Fig. 29:1), Inv. No. C-1302 (2) [034]Uncoated Nile B₂ W₂

Rim sherd; inverted articulated interior and exterior rim, folded lip. Rd: 18.00 cm 3/32; Wd: 1.00 cm; H₁: 3.50 + x cm; throwing lines inside; smoothed on the wheel. Another, Rd: 19.00 cm 3/32

No. 8: jar (Fig. 29:1), Inv. No. C-1302 (2) [031]Uncoated Nile B₂ W₂

Rim sherd; vertical direct rim. Rd: 12.00 cm 5/32; Wd: 1.00 cm; H₁: 6.30 + x cm; throwing lines inside; smoothed on the wheel. Another, Rd: 10.00 cm 5/32.

No. 9: jar (Fig. 29:1), Inv. No. C-1302 (2) [013]Uncoated Nile B₂ W₂

Rim sherd; vertical articulated exterior rim. Rd: 18.00 cm 1/32; Wd: 0.70 cm; H₁: 3.50 + x cm; throwing lines inside; smoothed on the wheel.

No. 10: jar (Fig. 29:1), Inv. No. C-1302 (2) [006]Uncoated Nile B₂ W₂

Rim sherd; everted direct rim. Rd: 10.00 cm 5/32; Wd: 0.60 cm; H₁: 5.50 + x cm; throwing lines inside; smoothed on the wheel. Others, Rd: 13.00 cm 3/32, Rd: 20.00 cm 1/8.

No. 11: jar, Inv. No. C-1302 (2) [024]Uncoated Nile B₂ W₂ base finished on the wheel

Base fragment; pointed base. Md: 14.00 + x cm; Wd: 0.60 cm; H₁: 6.00 + x cm; throwing

lines inside and outside; smoothed on the wheel. Others, 3 bases.

No. 12: jar, Inv. No. C-1302 (2) [021]

Uncoated	Nile B ₂	W ₂	W
----------	---------------------	----------------	---

Base fragment; round base. Wd: 1.00 cm; H₁: 5.50 + x cm; throwing lines inside; smoothed on the wheel.

No. 13: storage jar (Fig. 29:2), Inv. No. C-1302 (2) [001]

Uncoated	Nile B ₂	W ₂
----------	---------------------	----------------

Rim sherd; inverted direct rim. Rd: 26.00 cm 1/8; Wd: 1.00 cm; H₁: 5.50 + x cm; throwing lines inside; smoothed on the wheel. Others, Rd: 24.00 cm 1/8, Rd: 24.00 cm 3/32.

No. 14: storage jar (Fig. 29:2), Inv. No. C-1302 (2) [007]

Uncoated	Nile B ₂	W ₂
----------	---------------------	----------------

Rim sherd; inverted articulated exterior rim. Rd: 26.00 cm 1/8; Wd: 0.70 cm; H₁: 4.50 + x cm; throwing lines inside; smoothed on the wheel. Others, Rd: 22.00 cm 1/4, Rd: 30.00 cm 3/32.

No. 15: storage jar (Fig. 29:2), Inv. No. C-1302 (2) [026]

Uncoated	Nile B ₂	W ₂
----------	---------------------	----------------

Rim sherd; inverted articulated exterior rim, folded lip. Rd: 22.00 cm 1/8; Wd: 1.00 cm; H₁: 5.50 + x cm; throwing lines inside; smoothed on the wheel.

No. 16: storage jar (Fig. 29:2), Inv. No. C-1302 (2) [030]

Uncoated	Nile B ₂	W ₂
----------	---------------------	----------------

Rim sherd; slightly inverted articulated interior rim. Rd: 30.00 cm 8/16; Wd: 1.10 cm; H₁: 6.50 + x cm; throwing lines inside; smoothed on the wheel.

No. 17: storage jar (Fig. 29:2), Inv. No. C-1302 (2) [029]

Uncoated	Nile B ₂	W ₂
----------	---------------------	----------------

Rim sherd; inverted articulated interior and exterior rim. Rd: 30.00 cm 3/32; Wd: 0.80 cm; H₁: 5.50 + x cm; throwing lines inside; smoothed on the wheel.

No. 18: storage jar, Inv. No. C-1302 (2) [061]

Uncoated	Nile B ₂	W ₂
----------	---------------------	----------------

Rim sherd; vertical direct rim. Rd: 30.00 cm 3/32; Wd: 0.70 cm; H₁: 7.50 + x cm; throwing lines inside; smoothed on the wheel.

No. 19: storage jar (Fig. 29:2), Inv. No. C-1302 (2) [059]

Uncoated	Nile B ₂	W ₂
----------	---------------------	----------------

Rim sherd; vertical articulated exterior rim. Rd: 31.00 cm 3/32; Wd: 1.00 cm; H₁: 8.00 + x cm; throwing lines inside; smoothed on the wheel. Another, Rd: 38.00 cm 3/16.

Pottery with special functions

No. 20: lid (Fig. 29:2), Inv. No. C-1302 (2) [010]

Uncoated	Nile B ₂	W ₂
----------	---------------------	----------------

Rim sherd; everted direct rim. Rd: 28.00 cm 1/8; Wd: 0.58 cm; H₁: 1.10 + x cm; throwing lines inside; smoothed on the wheel.

No. 21: bakery tray (Fig. 29:2), Inv. No. P1308A (Drawing No. 0652)

Uncoated	Nile B ₂	W ₁	Ha	me.	2
----------	---------------------	----------------	----	-----	---

Complete, fragmentary; everted direct rim. Rd: 26.00 cm 5/32; Bd: 24.00 cm 5/32; Wd: 0.85-1.60 cm; H₁: 6.10 cm; VI: 426. Surface colour: 10R 5/8 red. Break: 10R 4/1 dark reddish grey core; 10R 5/8 red oxidation zones. Surface treatment: uneven.

No. 22: “pigeon pot”, Inv. No. C-1302 (2) [063]

Uncoated	Nile B ₂	W ₂	W
----------	---------------------	----------------	---

Base fragment. Bd: 4.00 cm 1/32; Wd: 0.80 cm; H₁: 4.00 + x cm; throwing lines inside; smoothed on the wheel; eroded.

Egyptian marls

Household ware

No. 23: jar, Inv. No. C-1302 (2) [051]

Uncoated	Marl F	Ha ₂
----------	--------	-----------------

Handle fragment; loop handle. Hd: 3.10 x 2.70 cm; smoothed.

b) Imported pottery

Levantine fine ware

No. 24: jar (Fig. 29:3), Inv. No. P1104A (Drawing No. 0621)

RPMO	≅ IV.TG 08 c.	W ₂	---	ox.	3
------	---------------	----------------	-----	-----	---

Rim and neck fragment; everted articulated interior lip. Rd: 9.00 cm 1/2; Nd: 5.00 cm 1/4; Wd: 0.50 cm; H₃: 5.30 + x cm. Surface colour: 10R 4/8 red slip. Break: 2.5YR 5/6 red. Technical details: throwing lines inside; smoothed on the wheel. Decoration: horizontally painted lines, three on the neck, 2 and 3 mm wide, and two on the top of the rim, 6 mm wide, 10R 5/1 reddish grey. Surface treatment: polished, lustre medium.

Levantine household ware

No. 25: amphora, IV.TG 29, body sherds, 2.00 dm².

No. 26: amphora, IV.TG 51 (= TD IV.19), body sherds, 1.60 dm².

No. 27: amphora, IV.TG 61 burnt, body sherds, 2.00 dm².

Cypriote household ware

No. 28: amphora, VI.TG 04, body sherds, 0.10 dm².

Aegean fine ware

No. 29: pilgrim flask (Fig. 29:3), Inv. No. P1105A (Drawing No. 0922)

WP	VII TG 39	W ₂	---	re.	3
----	-----------	----------------	-----	-----	---

Neck and handle fragment, oval section, single strap. Wd: 0.30 cm; H₁: 2.50 + x cm; Hd: 0.80 x 0.50 cm. Surface colour: 7.5YR 8/3 pink slip. Break: 7.5YR 4/1 dark grey. Surface treatment: polished.

II.- Finds

Religion

Amulet

No. 30: wdjat eye (Fig. 29:3), Inv. No. F0686 (Drawing No. 0449). Complete; faience; moulded. 1.20 x 0.97 x 0.35 cm. Colour: 2.5Y 8/1 (white). SCA No. 4026. Find No. 011.

Personal objects

No. 31: beads (6) (Fig. 29:3), Inv. No. F0679 (Drawing No. 0449). 1) complete; 2) fragmentary; 3), 4), 5) and 6): complete. Faience; moulded. 1) 0.50 x 0.30 cm; 2) 1.60 x 0.70 cm; 3) 0.74 x 0.30 cm. Colour: 1) 10YR 7/2 (light grey) and 10YR 6/2 (light brownish grey); 2) 10YR 6/3 (pale brown); 3) 10YR 6/3 (pale brown) 4, 5 and 6 10YR 7/2

(light grey). Shape: 1, 2), 4), 5), 6): cylindrical shape; 3) prismatic shape. Reconstructed string. SCA No. 4018. *Find No. 006*.

No. 32: beads (3), Inv. No. F0704A (Drawing No. 0457). Complete; faience; moulded. 1) 0.55 x 0.24 cm; 2) 0.27 x 0.49 cm; 3) 0.68 x 0.25 cm. Colour: 1) Chart 1 for gley B/10 GY (light greenish grey); 2) Chart 1 for gley 3N (very dark grey); 3) 10YR 8/1 (white). Cylindrical shape; 1) and 2) perforation: 1 mm; 3) perforation: 2.5 mm. *Find No. 012*.

No. 33: beads (2) (Fig. 29:3), Inv. No. F0598A (Drawing No. 0460). Complete; faience; moulded. 1) 0.70 x 0.30 cm; 2) 0.20 x 0.40 cm (compound bead). Colour: 1) 7.5YR 2.5/1 (black); 2) 7.5YR 6/2 (pinkish grey). Cylindrical shape; 1) perforation: 1 mm; 2) perforation: 2 mm. *Find No. 003*.

Tools

No. 34: needle? (Fig. 29:3), Inv. No. F0632 (Drawing No. 0437). Fragmentary; bone. 9.04 x 1.05 cm; oval shape, round section. SCA No. 4009. *Find No. 002*.

No. 35: sharpener, Inv. No. F0675A (Drawing No. 0653). Pumice. 5.80 x 3.10 x 2.10 cm. *Find No. 004*.

No. 36: tool by use, Inv. No. 1085A (before Inv. No. 0922B). Primary form: flake. Weight: 2kg+. 1.90 x 1.20 x 1.10 cm; smoked. *Find No. 10*.

Weight

No. 37: net weight (Fig. 29:4), Inv. No. F0934A (Drawing No. 0943). Complete; limestone. 7.70 x 4.40 x 3.70 cm; two grooves for fastening, 3 mm wide. Function: fishing. *Find No. 013*.

Objects of unknown use

No. 38: fragments (2) of an object, Inv. No. F0767A. Bronze. 1) 1.71 x 1.39 x 0.89 cm; 2) 1.00 x 0.68 x 0.46 cm. *Find No. 009*.

No. 39: fragment of an object, Inv. No. F0676A. Bronze. 1.30 x 0.95 x 3.02 cm. *Find No. 009*.

No. 40: fragments (2) of an object, Inv. No. F0644A. Bronze. 1) 0.60 x 1.22 x 0.70 cm; 2) 0.66 x 0.54 x 0.50 cm. *Find No. 005*.

Raw material

No. 41: faience slag, Inv. No. F0855A and Inv. No. F0669A. *Find No. 009*.

L1407 (Fig. 30)

Pottery

Egyptian pottery

Nile silt clay

Household ware

No. 1: jar, Inv. No. C-1336 [003]

Uncoated	Nile B ₂	Ha ₂
----------	---------------------	-----------------

Handle fragment; loop handle. Hd: 2.80 x 2.00 cm; eroded.

No. 2: storage jar (Fig. 30), Inv. No. C-1336 [002]

Uncoated	Nile B ₂	W ₂
----------	---------------------	----------------

Rim and wall fragment; inverted articulated exterior rim, round lip. Rd: 24.00 cm 1/8; Wd: 0.9 cm; H₁: 5.40 + x cm; throwing lines inside; eroded. Another, Rd: 26.00 cm 1/8.

Body sherds, Nile B₂, 4 dm²; Nile C₂, 0.50 dm².

L1417 (Fig. 31)**I.- Pottery****Egyptian pottery****Nile silt clay*****Egyptian painted ware******Black on Red slipped ware*****No. 1: jar (Fig. 31:1), Inv. No. P1113A (Drawing No. 0630)**BPMO | Nile B₂ | W₂ | --- | re. | 2

Body sherd. Md: 14.20 cm; Wd: 0.50 cm; H₁: 5.70 + x cm. Surface colour: 2.5YR 5/4 reddish brown slip. Break: 2.5YR 3/1 dark reddish grey. Technical details: throwing lines inside. Decoration: three horizontally painted bands, 2.5 mm wide, 2.5YR 4/1 dark reddish grey. Surface treatment: smoothed on the wheel.

Household ware**No. 2: bowl (Fig. 31:1), Inv. No. P1112A (Drawing No. 0524/0929)**RS | Nile E₂ | W₂ | --- | ox. | 2

Rim, shoulder and body fragment; carinated bowl; vertical direct rim. Rd: 13.00 cm 1/16; Md: 13.30 cm; Wd: 0.55 cm; H₁: 5.50 + x cm. Surface colour: 10R 5/6 red slip. Break: 10R 5/6 red. Technical details: throwing lines inside. Surface treatment: smoothed on the wheel.

No. 3: bowl (Fig. 31:1), Inv. No. C-1318 (2) [002]Uncoated | Nile B₂ | W₂

Rim sherd; vertical articulated exterior rim, modelled lip. Rd: 32.00 cm 1/8; Wd: 1.00 cm, H₁: 3.60 + x cm; smoothed on the wheel.

No. 4: bowl (Fig. 31:1), Inv. No. C-1318 (4) [011]Uncoated | Nile B₂ | W₂

Rim sherd; everted direct rim. Rd: 21.00 cm 1/8; Wd: 0.65 cm; H₁: 3.20 + x cm; smoothed on the wheel. Others, Rd: 20.00 cm 3/32, Rd: 21.00 cm 3/32, Rd: 24.00 cm 1/8, Rd: 25.00 cm 1/16, Rd: 26.00 cm 3/64, Rd: 34.00 cm 1/16.

No. 5: bowl (Fig. 31:1), Inv. No. C-1318 (2) [001]RS | Nile B₂ | W₂

Rim sherd; straight walls, everted articulated interior rim, modelled lip. Rd: 20.00 cm 1/16; Wd: 1.00 cm; H₁: 5.50 + x cm; red slipped; smoothed on the wheel.

No. 6: deep bowl (Fig. 31:1), Inv. No. C-1318 (4) [010]Uncoated | Nile B₂ | W₂

Rim sherd; everted direct rim. Rd: 13.00 cm 3/32; H₁: 3.10 + x cm; smoothed on the wheel.

No. 7: pilgrim flask (Fig. 31:2), Inv. No. P1153A (Drawing No. 0523)Uncoated | Nile B₂ | Ha₂ + W₂ | --- | ox. | 2

Incomplete, fragmentary; mended; lentil shape; rim not preserved. Nd: 1.00 cm; Md: 6.95 x 3.40 cm; Wd: 0.30-0.50 cm; H₁: 9.95 + x cm; H₂: 3.50 cm; H₃: 2.40 + x cm. Surface colour: 7.5YR 5/3 brown. Break: 2.5YR 3/1 dark reddish grey; 7.5YR 5/3 brown oxidation zones. Technical details: made in two halves which are then joined. Surface treatment: smoothed.

No. 8: jar (Fig. 31:2), Inv. No. C-1318 (4) [020]

Uncoated	Nile B ₂	W ₂
----------	---------------------	----------------

Rim, neck, shoulder and handle fragment; vertical direct rim; attached from rim to shoulder vertical loop handle. Rd: 8.00 cm 1/8; H₁: 5.80 + x cm; Hd: 1.60 x 0.90 cm; 1; single strap. Throwing lines inside; smoothed on the wheel. Others, Rd: 8.00 cm 1/4, Rd: 11.00 cm 7/32, Rd: 18.00 cm 1/32.

No. 9: jar (Fig. 31:2), Inv. No. C-1318 (2) [005]

Uncoated	Nile B ₂	W ₂
----------	---------------------	----------------

Rim sherd; straight walls, slightly inverted articulated exterior rim, modelled lip. Rd: 18.00 cm 3/32; Wd: 0.90 cm; H₁: 4.90 + x cm. Throwing lines inside; smoothed on the wheel.

No. 10: jar (Fig. 31:2), Inv. No. C-1318 (4) [009]

Uncoated	Nile B ₂	W ₂
----------	---------------------	----------------

Rim sherd; everted direct rim. Rd: 6.00 cm 1/4; H₁: 3.10 + x cm. Throwing lines inside; smoothed on the wheel.

No. 11: jar?, Inv. No. C-1318 [006]

Uncoated	Nile B ₂	W ₂	W
----------	---------------------	----------------	---

Base fragment; flat base; Bd: 6.00 cm 3/16; H₁: 5.00 + x cm; smoothed on the wheel.

No. 12: jar, Inv. No. C-1318

Uncoated	Nile B ₂	W ₂	base finished on the wheel
----------	---------------------	----------------	----------------------------

Base fragment; pointed base; H₁: 5.00 + x cm. Throwing lines inside and outside; smoothed on the wheel. Others, 2 bases.

No. 13: jar, Inv. No. C-1318 (2) [008]

Uncoated	Nile B ₂	W ₂	W
----------	---------------------	----------------	---

Base fragment; round base. Md: 11.00 cm; H₁: 3.30 + x cm. Throwing lines inside; smoothed on the wheel. Others, 3 bases.

No. 14: jar (handle), Inv. No. C-1318 (4) Nile B₂, Hd: 3.20 x 2.30 cm; smoothed. Others, Hd: 3.00 x 1.70 cm; Hd: 3.20 x 2.40 cm.

No. 15: storage jar (Fig. 31:2), Inv. No. C-1318 (2) [003]

Uncoated	Nile B ₂	W ₂
----------	---------------------	----------------

Rim and body fragment; straight walls, inverted articulated exterior rim, round lip. Rd: 25.00 cm 5/32; Wd: 1.20 cm; H₁: 6.70 + x cm. Throwing lines inside; smoothed on the wheel.

No. 16: storage jar (Fig. 31:2), Inv. No. C-1318 (4) [001]

Uncoated	Nile B ₂	W ₂
----------	---------------------	----------------

Rim sherd; inverted articulated exterior rim, modelled lip. Rd: 28.00 cm 1/16; H₁: 5.00 + x cm. Throwing lines inside; smoothed on the wheel.

No. 17: storage jar (Fig. 31:3), Inv. No. C-1318 (4) [003]

Uncoated	Nile B ₂	W ₂
----------	---------------------	----------------

Rim and handle fragment, attached from neck to body vertical loop handle, vertical articulated exterior rim, modelled lip. Rd: 35.00 cm 3/32; H₁: 7.10 + x cm; Hd: 2.30 x 2.00 cm; 1; single strap. Throwing lines inside; smoothed on the wheel. Others, Rd: 24.00 cm 1/8, Rd: 30.00 cm 1/16.

No. 18: storage jar (Fig. 31:3), Inv. No. C-1318 (4) [005]Uncoated | Nile B₂ | W₂

Rim sherd; vertical simmetrical rim, round lip. Rd: 26.00 cm 1/8; H₁: 2.50 + x cm. Throwing lines inside; smoothed on the wheel; eroded.

Pottery with special functions**No. 19: bakery tray (Fig. 31:3), Inv. No. C-1318 (4) [004]**Uncoated | Nile C₁ | W₁ | Ha

Rim and base fragment; flat base, everted direct rim. Rd: 22.00 cm 3/16; Bd: 20.00 cm; H₁: 5.00 cm; VI: 400; eroded. Another, Rd: 34.00 cm 1/16.

Egyptian marls**Household ware****No. 20: jar, Inv. No. C-1318 (3) [002]**Uncoated | Marl A₄ | W₂ | W

Base fragment; round base; Md: 7.00 cm; H₁: 3.00 + x cm. Throwing lines inside; smoothed on the wheel.

No. 21: amphora (Fig. 31:3), Inv. No. C-1318 (3) [001]Uncoated | Marl F | W₂

Rim sherd; everted direct rim. Rd: 10.00 cm 1/1; H₁: 5.00 + x cm. Throwing lines inside; smoothed on the wheel.

No. 22: amphora (Fig. 31:3), Inv. No. C-1318 [005]Uncoated | Marl F | W₂

Shoulder and handle fragment; attached from shoulder to body vertical loop handle. Md: 16.00 cm on the shoulder; Wd: 0.90 cm; H₁: 9.50 + x cm; Hd: 2.30 x 1.70 cm; 1; single strap. Throwing lines inside; smoothed on the wheel.

No. 23: amphora, Inv. No. C-1318 (3) [003]Uncoated | Marl F + limestone | Ha₂ + W₂

Handle and body fragment; attached vertical loop handle. H₁: 16.00 + x cm; Hd: 2.70 x 1.90 cm. Throwing lines inside; smoothed on the wheel.

Body sherds, Nile B₂: 170.00 dm²; Nile C₂: 7 dm²; Marl A₄ + limestone, Marl F.

b) North Sinai/South Palestine pottery**Household ware**

No. 24: amphora, Inv. No. C-1318 (2), II.TG 10, body sherd.

c) Imported pottery**Levantine household ware**

No. 25: amphora, Inv. No. C-1318 (2), IV.TG 24, body sherd: 0.10 dm².

No. 26: amphora, Inv. No. C-1318 (2), IV.TG 52 (=TD IV.19 c.), body sherd.

No. 27: amphora (Fig. 31:3), Inv. No. C-1318 (2) [009]Uncoated | IV.TG 53 c. (=TD IV.09) | W₂

Rim sherd; vertical direct rim. Rd: 9.00 cm 1/8; Wd: 0.90 cm; H₁: 3.40 + x cm; throwing lines inside; smoothed on the wheel.

Cypriote fine ware**No. 28: jar** (Fig. 31:4), Inv. No. P1148A (Drawing No. 0713)

WPMO	VI.TG 40 c.	W ₂	---	ox.	3
------	-------------	----------------	-----	-----	---

Neck and body fragments (reconstructed shape); barrel-shaped jar. Nd: 3.00 cm 5/32; Md: 17.00 cm; Wd: 0.50 cm. Surface colour: 2.5Y 8/4 pale yellow slip. Break: 5Y 7/3 pale yellow. Technidak details; body made in two halves which are then joined; finger marks inside the neck. Decoration: circular painted lines, 1.5-3 mm wide and 0.70 + x mm wide, 7.5YR 4/2 brown. Surface treatment: polished, low lustre.

Cypriote household ware**No. 29: amphora**, Inv. No. C-1318 (2), VI.TG 44, body sherd: 0.20 dm².**II.- Finds*****Grinding stone***

No. 30: hand? (Fig. 31:4), Inv. No. F0910A (before Inv. No. F0909B. Drawing No. 0906/1085). Fragmentary; reddish sandstone. 10.80 cm x 4.00 cm. Primary form: cobble. Manufacture technique: pecking and polishing. Degree of wear: 2-Medium. Wear marks: striations. Surfaces: 1. Surface configuration: flat. Surface texture: smoothed. Stroke: combination.

Raw material**No. 31: bitumen**, Inv. No. F0841A. *Find No. 001*.**L1421****Finds*****Personal objects***

No. 1: bead, Inv. No. F0586A (Drawing No. 0459). Complete; faience; moulded. 0.40 x 0.10 cm; colour: 10YR 6/2 (light brownish grey). Cylindrical shape; perforation: 1 mm. *Find No. 004*.

No. 2: bead, Inv. No. F0588 (Drawing No. 0451). Complete; faience; moulded. 0.80 x 0.20 cm; colour: 5YR 3/1 (very dark grey). Cylindrical shape; perforation: 1 mm. SCA No. 4021. *Find No. 005*.

L1423 (Fig. 32)**Egyptian pottery****Nile silt clay*****Household ware*****No. 1: deep bowl** (Fig. 32), Inv. No. C-1315 [001]

Uncoated	Nile B ₂	W ₂
----------	---------------------	----------------

Rim sherd; straight walls, everted articulated exterior rim, modelled lip. Rd: 20.00 cm 3/32; Wd: 0.80 cm; H₁: 6.70 + x cm. Throwing lines inside; smoothed on the wheel; eroded.

No. 2: jar (Fig. 32), Inv. No. C-1315 [002]

Uncoated	Nile B ₂	W ₂
----------	---------------------	----------------

Rim sherd; slightly everted direct rim. Rd: 10.00 cm 1/8; Wd: 0.55 cm; H₁: 3.60 + x cm. Throwing lines inside; smoothed on the wheel; eroded.

Body sherds, Nile B₂, Nile C₂.

LEVEL III: Decay of Building L and utilization of the place before the erection of Building D

1.- General description

Floors L1224 and L1225 were covered by **L1219**, a thick (ca. 50 cm), homogeneous greenish clayey layer (*muna*). After some hours of exposure, its surface crackles. The only inclusions in L1219 were fragments of mud bricks and remains of mollusc shells which entered in the composition of the latter. This layer resulted from the abandonment and decay of this part of Building L. Since in room L-4, a hearth (L1227) was kindled when the walls had partially crumbled, the lower part of this *muna* was identified here as L1226.

Afterwards, the area served to open-air activities, as suggested by a series of superimposed fire features. These contributed with a share of charcoal to the surrounding sediments, which are still clayey but darker than the underlying *muna*. Hearth L1223 was placed in the depression corresponding to the opening in wall **L1217**. Later, a pit at least 2 m wide was dug in order to set another hearth, **L1221**, which oxidised the basin. Two successive levels of charcoal were recognized in this fire feature, which was associated to many sherds and later was disturbed by a krotovina. It was followed by another hearth, L1222. Although crumbling down, the walls of Building L could still provide some shelter. To the south, a later feature, hearth L1220, cut the remains of wall L1217, which was by that time level with the surface.

This part of the excavation was subsequently covered, in unconformity, by a thick, brown sediment, still rich in clay but not as plastic as L1219 and breaking in lumps. The crumbling walls of Building L were still contributing to the fill with broken mud bricks and fragments of mollusc shells derived from them. The lower portion was identified as **L1214** and the upper one as **L1212**. Between them was a thin lens of clean sand, L1430. Many sherds associated with L1212 and L1214.

Building D covered these loci and was in turn weathered away except for its foundations. When the Argentine Mission began its work, the area was blanketed by a sandy topsoil.

2.- Archaeological material

L1212 (Fig. 33)

I.- Pottery

a) Egyptian pottery

Nile silt clay

Fine ware

Egyptian painted ware

Black on Red slip ware

No. 1: jar (Fig. 33), Inv. No. P0868A (Drawing No. 0630)

RSMO	Nile B ₂	W ₂	---	re.	2
------	---------------------	----------------	-----	-----	---

Body sherd. Md: 16.00 + x cm; Wd: 0.75 cm; H₁: 3.70 + x cm. Surface colour: 2.5YR 4/4 reddish brown slip. Break: 2.5YR 4/1 drak reddish grey. Technical details: throwing lines inside. Decoration: three horizontally painted bands, 3 mm wide, 5YR 4/1 dark grey. Surface treatment: smoothed on the wheel.

Household ware

No. 2: bowl (Fig. 33), Inv. No. C-1059 [005]

Uncoated	Nile B ₂	W ₂
----------	---------------------	----------------

Rim sherd; everted direct rim. Rd: 22.00 cm 1/8; Wd: 0.76 cm; H_1 : 3.27 + x cm; smoothed on the wheel.

No. 3: bowl (Fig. 33), Inv. No. C-1059 [004]

Uncoated	Nile B ₂	W ₂
----------	---------------------	----------------

Rim sherd; everted direct rim. Rd: 22.00 cm 1/8; Wd: 0.75 cm; H_1 : 3.00 + x cm; smoothed on the wheel. Others, Rd: 16.00 cm 5/32, Rd: 22.00 cm 3/16, Rd: 24.00 cm 1/16.

No. 4: jar (Fig. 33), Inv. No. C-1059 [006]

Uncoated	Nile B ₂	W ₂
----------	---------------------	----------------

Rim sherd; vertical direct rim. Rd: 18.00 cm 3/16; Wd: 0.60 cm; H_1 : 3.82 + x cm; throwing lines inside; smoothed on the wheel.

No. 5: jar (Fig. 33), Inv. No. C-1059 [001]

Uncoated	Nile B ₂	W ₂
----------	---------------------	----------------

Rim sherd; vertical articulated interior and exterior rim. Rd: 18.00 cm 1/8; Wd: 0.94 cm; H_1 : 4.65 + x cm; throwing lines inside; smoothed on the wheel.

No. 6: jar (Fig. 33), Inv. No. C-1059 [003]

Uncoated	Nile B _{2s}	W ₂
----------	----------------------	----------------

Rim sherd; everted articulated exterior rim. Rd: 18.00 cm 5/64; Wd: 1.35 cm; H_1 : 3.67 + x cm; throwing lines inside; smoothed on the wheel.

No. 7: storage jar (Fig. 33), Inv. No. C-1059 [002]

Uncoated	Nile B ₂	W ₂
----------	---------------------	----------------

Rim sherd; everted irregular lip. Rd: 24.00 cm 1/16; Wd: 0.97 cm; H_1 : 2.87 + x cm; throwing lines inside; smoothed on the wheel.

No. 8: storage jar, Inv. No. P7042A (Drawing No. 0918)

Uncoated	Nile B ₂	W ₁	---	ox.	2
----------	---------------------	----------------	-----	-----	---

Body sherd. Md: ca. 50.0 cm²; Wd: 2.5 cm.

No. 9: storage jar, Inv. No. C-1059

Uncoated	Nile B ₂	W ₂
----------	---------------------	----------------

Swelling of a handle and body fragment; very eroded.

Body sherds, Nile B₂.

II.- Finds

Raw material

No. 10: debris, Inv. No. F0970A. Chert, very pale brown. 5.50 x 2.20 x 2.40 cm.

L1214 (Fig. 34)

I.- Pottery

a) Egyptian pottery

Nile silt clay

Household ware

No. 1: bowl (Fig. 34:1), Inv. No. C-1312 (3) [001]

Uncoated	Nile B ₂	W ₂
----------	---------------------	----------------

Rim sherd; inverted direct rim. Rd: 10.00 cm 1/16; Wd: 0.41 cm; H_1 : 2.50 + x cm;

smoothed on the wheel.

No. 2: bowl (Fig. 34:1), Inv. No. C-1312 [016]

Uncoated Nile B₂ W₂

Rim sherd; everted direct rim. Rd: 26.00 cm 1/8; Wd: 0.97 cm; H₁: 5.18 + x cm; smoothed on the wheel; eroded. Another, Rd: 26.00 cm 1/16.

No. 3: bowl (Fig. 34:1), Inv. No. C-1312 [003]

Uncoated Nile B₂ W₂

Rim sherd; everted articulated exterior rim. Rd: 20.00 cm 3/32; Wd: 1.14 cm; H₁: 5.54 + x cm; smoothed on the wheel; eroded.

No. 4: bowl, Inv. No. C-1312 [026]

Uncoated Nile B₂ W₂ base finished on the wheel

Base fragment; ring base (R₃). Bd: 6.00 cm; Wd: 1.00 cm; H₁: 3.87 + x cm; smoothed on the wheel.

No. 5: cup, Inv. No. C-1312 [025]

Uncoated Nile B₂ W₂ base finished on the wheel

Base fragment; pointed base; Wd: 0.38 cm; H₁: 1.53 + x cm. Throwing lines inside and outside; smoothed on the wheel. Another, 1 base.

No. 6: jar (Fig. 34:1), Inv. No. C-1073 (2) [001]

Uncoated Nile B₂ W₂

Rim sherd; inverted direct rim. Rd: 12.00 cm 1/4; Wd: 0.60 cm; H₁: 3.00 + x cm. Throwing lines inside; smoothed on the wheel; eroded.

No. 7: jar (Fig. 34:1), Inv. No. C-1312 [011]

Uncoated Nile B₂ W₂

Rim sherd; vertical direct rim. Rd: 14.00 cm 3/16; Wd: 0.81 cm; H₁: 5.00 + x cm. Throwing lines inside; smoothed on the wheel. Others, Rd: 8.00 cm 3/16, Rd: 8.00 cm 3/32.

No. 8: jar (Fig. 34:1), Inv. No. C-1312 [009]

Uncoated Nile B₂ W₂

Rim sherd; everted articulated exterior rim, modelled lip. Rd: 16.00 cm 7/32; Wd: 1.05 cm; H₁: 10.00 + x cm. Throwing lines inside; smoothed on the wheel. Another, Rd: 18.00 cm 1/8.

No. 9: jar (Fig. 34:1), Inv. No. C-1312 [012]

Uncoated Nile B₂ W₂

Rim sherd; everted articulated exterior rim, round lip. Rd: 18.00 cm 1/4; Wd: 0.67 cm; H₁: 6.74 + x cm. Throwing lines inside; smoothed on the wheel. Another, Rd: 14.00 cm 1/8, Rd: 16.00 cm 3/32.

No. 10: jar (Fig. 34:1), Inv. No. C-1312 (2) [004]

Uncoated Nile B₂ W₂

Rim sherd; everted direct rim. Rd: 12.00 cm 1/8; Wd: 0.90 cm; H₁: 3.10 + x cm. Throwing lines inside; smoothed on the wheel; eroded. Another, Rd: 16.00 cm 3/32.

No. 11: jar (Fig. 34:1), Inv. No. C-1312 [007]

Uncoated	Nile B ₂	W ₂
----------	---------------------	----------------

Rim sherd; everted articulated interior and exterior rim, rounded lip. Rd: 14.00 cm 3/16; Wd: 0.93 cm; H₁: 7.00 + x cm. Throwing lines inside; smoothed on the wheel.

No. 12: jar, Inv. No. C-1312 [024]

Uncoated	Nile B ₂	W ₂	base finished on the wheel
----------	---------------------	----------------	----------------------------

Base fragment; pointed base; Wd: 0.68 cm; H₁: 1.70 + x cm. Throwing lines inside and outside; smoothed on the wheel.

No. 13: jar, Inv. No. C-1073 (2) [004]

Uncoated	Nile B ₂	W ₂
----------	---------------------	----------------

Base fragment; round base; very eroded.

No. 14: jar, Inv. No. C-1312 (2) [007]

Uncoated	Nile B ₂	W ₂
----------	---------------------	----------------

Handle fragment; loop handle; Hd: 3.20 x 2.40 cm; 1; single strap; eroded.

No. 15: jar, Inv. No. C-1312 [020]

Uncoated	Nile B ₂	W ₂
----------	---------------------	----------------

Handle and body fragment; body to body attached vertical loop handle. Wd: 0.90 cm; H₁: 7.50 + x cm; Hd: 1.99 x 3.00 cm; 1; single strap; smoothed. Others, Hd: 2.85 x 1.69 cm; Hd: 2.80 x 2.50 cm.

No. 16: storage jar (Fig. 34:1), Inv. No. C-1312 (2) [005]

Uncoated	Nile B ₂	W ₂
----------	---------------------	----------------

Rim sherd; inverted incurved rim. Rd: 22.00 cm 1/8; Wd: 1.00 cm; H₁: 3.60 + x cm. Throwing lines inside; smoothed on the wheel; eroded.

No. 17: storage jar (Fig. 34:1), Inv. No. C-1312 (2) [001]

Uncoated	Nile B ₂	W ₂
----------	---------------------	----------------

Rim sherd; inverted articulated interior and exterior rim, modelled lip. Rd: 22.00 cm 1/8; Wd: 1.10 cm; H₁: 5.00 + x cm. Throwing lines inside; smoothed on the wheel; eroded. Another, Rd: 22.00 cm 3/32

No. 18: storage jar (Fig. 34:2), Inv. No. C-1312 [002]

Uncoated	Nile B ₂	W ₂
----------	---------------------	----------------

Rim sherd; undulated exterior wall; inverted articulated exterior rim. Rd: 20.00 cm 1/8; Wd: 0.81 cm; H₁: 6.00 + x cm. Throwing lines inside; smoothed on the wheel; eroded.

No. 19: storage jar (Fig. 34:2), Inv. No. C-1312 [008]

Uncoated	Nile B ₂	W ₂
----------	---------------------	----------------

Rim sherd; vertical articulated exterior rim, modelled lip. Rd: 28.00 cm 3/32; Wd: 1.55 cm; H₁: 7.50 + x cm. Throwing lines inside; smoothed on the wheel.

No. 20: storage jar (Fig. 34:2), Inv. No. C-1312 [001]

Uncoated	Nile C ₁	W ₂
----------	---------------------	----------------

Rim sherd; undulated exterior wall, everted direct rim. Rd: 22.00 cm 3/32; Wd: 1.16 cm; H₁: 4.00 + x cm. Throwing lines inside; smoothed on the wheel; eroded.

No. 21: storage jar, Inv. No. C-1073 (2) [006]

Uncoated	Nile B ₂	W ₂
----------	---------------------	----------------

Handle and wall fragment; attached vertical loop handle from body to body, straight walls. Wd: 1.60 cm; H₁: 9.00 + x cm; Hd: 4.60 x 2.90 cm; 1; single strap. Throwing lines inside; smoothed on the wheel; eroded. Another (handle), Hd: 3.93 x 2.00 cm.

Egyptian marls

Household ware

No. 22: juglet, Inv. No. C-1073 (2) [005]

Uncoated	Marl A ₄	W ₂ + Ha ₂
----------	---------------------	----------------------------------

Rim and handle fragment; attached vertical loop handle from rim to body; vertical direct rim. Rd: 4.00 cm 1/8; Wd: 0.30 cm; H₁: 2.30 + x cm; Hd: 1.30 x 1.15 cm; 1; single strap. Throwing lines inside; smoothed on the wheel; eroded.

No. 23: jar, Inv. No. C-1312 (2) [008]

Uncoated	Marl F	Ha ₂
----------	--------	-----------------

Handle fragment; loop handle. Hd: 3.50 x 2.10 cm; 1; single strap; eroded.

No. 24: amphora, Inv. No. C-1312 [019]

Uncoated	Marl F	W ₂ + Ha ₂
----------	--------	----------------------------------

Handle fragment; upper body-shoulder attached vertical loop handle; Wd: 0.76 cm; H₁: 13.70 + x cm; Hd: 2.10 x 2.90 cm; oval in section; 1; single strap; smoothed.

Body sherds, Nile B₂: 48.00 dm²; Nile B₂/C₁, Nile C₂: 14.50 dm²; Marl A₄, Marl A₄ c., Marl F.

b) North Sinai/South Palestine pottery

Household ware

No. 25: jar, Inv. No. C-1312 (2) [009]

Uncoated	II.TG 09	Ha ₂ + W ₂
----------	----------	----------------------------------

Handle and wall fragment; loop handle; Wd: 1.00 cm; Hd: 3.15 x 2.00 cm; single strap. Throwing lines inside; smoothed; eroded.

No. 26: amphora, II.TG 09, body sherds.

No. 27: amphora, II.TG 10, body sherds.

c) Imported pottery

Levantine household ware

No. 28: amphora, IV.TG 07, body sherds.

No. 29: amphora, IV.TG 23, body sherds.

No. 30: amphora, Inv. No. C-1312 [017]

Uncoated	IV.TG 24	Ha ₂ + W ₂
----------	----------	----------------------------------

Handle fragment; "torpedo" type; upper body-shoulder attached vertical loop. Wd: 0.92 cm; H₁: 12.13 + x cm; Hd: 1.80 x 2.76 cm; smoothed.

No. 31: amphora, IV.TG 24, body sherds.

No. 32: amphora, IV.TG 36, body sherds

No. 33: amphora (Fig. 34:2), Inv. No. C-1312 (2) [002]

Uncoated	IV.TG 51 (= TD IV.19)	W ₂
----------	-----------------------	----------------

Rim sherd; inverted direct rim. Rd: 10.00 cm 3/32; Wd: 0.70 cm; H₁: 3.50 + x cm.

Throwing lines inside; smoothed on the wheel; eroded.

No. 34: amphora (Fig. 34:2), Inv. No. C-1312 [018]

Uncoated	IV.TG 52 (= TD IV.19 c.)	Ha ₂ + W ₂
----------	--------------------------	----------------------------------

Handle fragment; "torpedo" type; upper body-shoulder attached vertical loop handle; Md: 23.00 + x cm; Wd: 1.00 cm; H₁: 11.10 + x cm; Hd: 1.92 x 2.62 cm; smoothed.

No. 35: amphora, IV.TG 53 (=TD IV.19), body sherds.

Cypriote fine ware

White Painted II ware

No. 36: jar or krater? (Fig. 34:3), Inv. No. P1150A (Drawing No. 0700)

WPMO	VI.TG 49	W ₂	---	me.	3
------	----------	----------------	-----	-----	---

Body sherd. Md: ca. 18.00 cm; Wd: 0.60 cm; H₁: 6.00 + x cm. Surface colour: 2.5YR 8/3 pale yellow slip. Break: 10YR 7/3 ver pale brown. Decoration: geometric pattern formed by vertically and horizontally painted bands and two crossed lines on the neck, and a band inside [the rim], 10YR 4/2 dark greyish brown. Surface treatment: polished, low lustre. *Find No. 004.*

No. 37: jar (Fig. 34:3), Inv. No. P1150Abis (Drawing No. 0700)

WPMO	VI.TG 49	W ₂	---	me.	3
------	----------	----------------	-----	-----	---

Body sherd. Md: ca. 14.00 cm; Wd: 1.00 cm; H₁: 4.00 + x cm. Surface colour: 2.5YR 8/3 pale yellow slip. Break: 10YR 7/3 ver pale brown. Decoration: horizontally painted lines, 3 mm and 1 mm wide, 10YR 4/2 dark greyish brown. Surface treatment: polished, low lustre. *Find No. 004.*

Cypriote household ware

No. 38: amphora, VI.TG 43, body sherds.

No. 39: amphora, VI.TG 44, body sherds.

L1219 (Fig. 35)

I.- Pottery

Egyptian pottery

Nile silt clay

Egyptian painted ware

No. 1: deep bowl, Inv. No. P1134A + 1122A (Drawing No. 0628). See Area II, L1228 = L1237 (Fig.23, 1).

Household ware

No. 2: bowl (Fig. 35:1), Inv. No. C-1311 (2) [006]

Uncoated	Nile B ₂	W ₂
----------	---------------------	----------------

Rim sherd; everted direct rim. Rd: 26.00 cm 3/16; Wd: 0.60 cm; H₁: 3.00 + x cm; smoothed on the wheel. Others, Rd: 20.00 cm 3/32, Rd: 24.00 cm 3/16.

No. 3: bowl (Fig. 35:1), Inv. No. C-1311 (2) [005]

Uncoated	Nile B ₂	W ₂
----------	---------------------	----------------

Rim sherd; everted direct rim. Rd: 24.00 cm 1/16; Wd: 1.00 cm; H₁: 4.00 + x cm; smoothed on the wheel.

No. 4: bowl (Fig. 35:1), Inv. No. C-1311 (2) [002]

Uncoated	Nile B ₂	W ₂
----------	---------------------	----------------

Rim sherd; everted articulated exterior rim. Rd: 31.00 cm 3/16; Wd: 1.15 cm; H₁: 4.00 + x cm; smoothed on the wheel.

No. 5: pilgrim flask, Inv. No. P7047A (Drawing No. 0924)

Uncoated	Nile B ₂	W ₂ + Ha ₂	---	ox.	2
----------	---------------------	----------------------------------	-----	-----	---

Neck, handle and shoulder fragment; lentil shape? Nd: 2.80 cm; Md: 9.00 + x cm; Wd: 0.60 cm; H₁: 3.20 + x cm; Hd: 1.50 x 1.35 cm. Surface colour: 2.5YR5/4 reddish brown. Break: 2.5YR 5/6 red. Technical details: applied handle from the shoulder to the [neck]; neck opened with a tool; body made in two halves which are then joined. Surface treatment: smoothed.

No. 6: jar (Fig. 35:1), Inv. No. C-1311 (2) [012]

Uncoated	Nile B ₂	W ₂
----------	---------------------	----------------

Rim sherd; vertical direct rim. Rd: 10.00 cm 1/8; Wd: 0.45 cm; H₁: 3.00 + x cm. Throwing lines inside; smoothed on the wheel. Others, Rd: 12.00 cm 1/8, Rd: 16.00 cm 3/16.

No. 7: handle, Inv. No. C-1311 (2) [001], Nile B₂; Hd: 3.00 x 1.70 cm; smoothed.

No. 8: storage jar (Fig. 35:1), Inv. No. P1206A (Drawing No. 0644)

Uncoated	Nile C ₁	W ₂	---	me.	2
----------	---------------------	----------------	-----	-----	---

Body and handle fragment; "sausage" type. Md: 27.00 + x cm; Wd: 1.60 cm; H₁: 69.50 + x cm; Hd: 4.60 x 2.60 cm. Surface colour: 2.5YR 6/4 light reddish brown. Break: 2.5YR 4/4 reddish brown interior, 7.5YR 6/4 light brown exterior. Surface treatment: smoothed on the wheel. *Find No. 011.*

No. 9: storage jar, Inv. No. P1249A

Uncoated	Nile B ₂	W ₂	---	ox.	2
----------	---------------------	----------------	-----	-----	---

Body fragment. Wd: 1.30 cm. Surface colour: 5YR 5/4 reddish brown. Break: grey core; red oxidation zones. Technical details: throwing lines inside. Surface treatment: smoothed on the wheel. *Find No. 003.*

No. 10: amphora (Fig. 35:1), Inv. No. C-1311 (2) [011]

Uncoated	Nile B ₂	W ₂
----------	---------------------	----------------

Shoulder fragment. Md: 30.00 cm; Wd: 0.75 cm; H₁: 7.30 + x cm. Throwing lines inside; smoothed on the wheel.

Pottery with special functions

No. 11: bakery tray (Fig. 35:1), Inv. No. P7050A (Drawing No. 0926)

Uncoated	Nile C ₂	W ₁	Ha	ox.	2
----------	---------------------	----------------	----	-----	---

Complete, fragmentary; rim 1/8 and base 5/32. Rd: 24.00 cm; Bd: 26.50 cm; Wd: 1.70 cm; H₁: 5.00 cm; VI: 530. Surface colour: 5YR 5/3 reddish brown. Break: 5YR 5/4 reddish brown. Technical details: finger prints on the base. Surface treatment: uneven.

No. 12: tray (Fig. 35:2), Inv. No. C-1311 (2) [013]

Uncoated	Nile C ₂	Ha ₁
----------	---------------------	-----------------

Fragment; Rd: 50.00 cm; eroded.

Egyptian marls

Household ware

No. 13: jar (Fig. 35:2), Inv. No. P1208A (Drawing No. 0520)

Uncoated	Marl A ₄	W ₂	---	ox.	3
----------	---------------------	----------------	-----	-----	---

Neck and rim fragment, articulated exterior rim. Rd: 10.00 cm 3/16; Wd: 0.50 cm; H₁: 3.80 + x cm; H₃: 3.80 cm. Surface colour: 10YR 7/3 very pale brown (self slip). Break: 5YR 6/4 light reddish brown core; 10YR 7/3 very pale brown oxidation zones. Technical details: throwing lines inside. Surface treatment: smoothed on the wheel.

b) North Sinai/South Palestine pottery

No. 14: amphora, II.TG 09, body sherds: 0.10 dm².

c) Imported pottery

Levantine fine ware

White Painted ware

No. 15: bowl, Inv. No. P1184A (Drawing No. 0701)

WPMO	IV.TG 53 (= TD IV.09)	W ₂	---	ox.	3
------	-----------------------	----------------	-----	-----	---

Body sherd. Md: 10.00 cm 3/32; Wd: 0.30 cm; H₁: 1.90 + x cm. Surface colour: 2.5Y 8/4 pale yellow slip. Break: 7.5YR 7/6 reddish yellow. Decoration: horizontally painted lines outside and inside, 1-2 mm wide, 7.5YR 6/3 light brown. Surface treatment: polished, low lustre. *Find No. 011*

No. 16: jar, Inv. No. P1229A (Drawing No. 0701)

BPMO	IV.TG 51 (=TD IV.19)	W ₂	---	med.	3
------	----------------------	----------------	-----	------	---

Body sherd. Md: ca. 16.00 cm; Wd: 0.40 cm; H₁: 2.10 + x cm. Surface colour: 10YR 8/4 very pale brown slip. Break: 10 Y/R 7/4 very pale brown. Decoration: obliquely painted lines, 3 mm wide, 10YR 4/1 dark grey. Surface treatment: polished, low lustre.

Bichrome ware

No. 17: jar, Inv. No. P7101A (Drawing No. 0926)

WPBI	IV.TG 24	W ₂	---	ox.	3
------	----------	----------------	-----	-----	---

Body sherd. Md: 12.00 + x cm; Wd: 0.60 cm; H₁: 0.90 + x cm. Surface colour: 5YR 6/6 reddish yellow slip. Break: 7.5YR 6/4 light brown - 6/6 reddish yellow. Decoration: a vertically painted band, 10R 5/6 red and 4/1 dark reddish grey. Surface treatment: polished, low lustre.

Bichrome III ware?

No. 18: juglet, Inv. No. P1228A (Drawing No. 0700)

WPBI	IV.TG 51 (=TD IV.19)	W ₂	---	ox.	3
------	----------------------	----------------	-----	-----	---

Body sherd. Md: 10.00 cm 3/32; Wd: 0.60 cm; H₁: 2.50 + x cm. Surface colour: 7.5YR 7/4 pink slip. Break: 5YR 6/4 light reddish brown. Technical details: throwing lines inside. Decoration: vertically painted lines 3 mm wide, 2.5YR 4/6 red. Surface treatment: polished, low lustre.

Levantine household ware

No. 19: amphora, IV.TG 07, body sherds: 0.20 dm².

No. 20: amphora, IV.TG 18, body sherds: 0.20 dm².

No. 21: amphora, IV.TG 24, body sherds: 0.20 dm².

No. 22: amphora, Inv. No. C-1311 (2) [010]

Uncoated	IV.TG 24	W ₂
----------	----------	----------------

Shoulder fragment; "torpedo" type. Md: 30.00 cm; H₁: 6.80 + x cm; throwing lines inside; smoothed on the wheel.

II.- Finds**Religion**

No. 23: wdjat?, Inv. No. F0687A. Faience; moulded. 1.34 x 1.07 x 0.25 cm; colour: light blue and 2.5YR 4/2 weak red; edge of a wdjat? *Find No. 006.*

Personal object

No. 24: bead, Inv. No. F0649A (Drawing No. 0463). Fragmentary; faience; moulded. 0.21 x 0.21 cm; colour: Chart 1 for gley 5/10 Y (greenish grey); cylindrical shape; perforation: 0.9 mm. *Find No. 003.*

Grinding stone

No. 25: netherstone (Fig. 35:2), Inv. No. F1100A (before Inv. No. F0937B. Drawing No. 0928 /1010). Granodiorite; primary form: cobble. Weight: 2 kg +. 22.00 x 11.80 x 8.30 cm. Used surface: 18.00 x 4.20 cm. Colour: dark grey. Degree of wear: 3-Hard. Wear type: pecking and grinding. Surface configuration: flat-concave; surface texture: smoothed.

L1221 (Fig. 36)**I.- Pottery****a) Egyptian pottery****Nile silt clay****Household ware**

No. 1: bowl (Fig. 36), Inv. No. C-1330 (3) [002]

Uncoated	Nile B ₂	W ₂
----------	---------------------	----------------

Rim sherd; everted direct rim. Rd: 32.00 cm 1/16; Wd: 1.20 cm; H₁: 4.50 + x cm; smoothed on the wheel. Others, Rd: 36.00 cm 3/32. Rd: 24.00 cm 1/16.

No. 2: bowl, Inv. No. C-1330 (3) [009]

Uncoated	Nile B ₂	W ₂	base finished on the wheel
----------	---------------------	----------------	----------------------------

Base fragment (R₃). Bd: 10.00 cm 7/32; Wd: 0.80 cm; H₁: 3.00 + x cm; eroded.

No. 3: shallow bowl (Fig. 36), Inv. No. C-1330 (3) [006]

Uncoated	Nile B ₂	W ₂
----------	---------------------	----------------

Rim sherd; everted articulated interior rim, round lip. Rd: 20.00 cm 1/16; Wd: 0.80 cm; H₁: 3.10 + x cm; eroded.

No. 4: [globular] jar (Fig. 36), Inv. No. C-1330 (2) [003]

Uncoated	Nile B ₂	W ₂
----------	---------------------	----------------

Rim sherd; everted direct rim. Rd: 8.00 cm 1/2; Wd: 0.50 cm; H₁: 4.50 + x cm; throwing lines inside; smoothed on the wheel.

No. 5: jar (Fig. 36), Inv. No. C-1330 (2) [017]

Uncoated	Nile B ₂	W ₂
----------	---------------------	----------------

Rim sherd; slightly inverted direct rim. Rd: 11.00 cm 3/32; Wd: 0.50 cm; H₁: 3.53 + x cm; throwing lines inside; smoothed on the wheel.

No. 6: jar, Inv. No. C-1330 (3) [005]

Uncoated	Nile B ₂	W ₂
----------	---------------------	----------------

Rim sherd; inverted articulated interior and exterior rim, trimmed lip. Rd: 16.00 cm 5/32; Wd: 1.45 cm; H₁: 4.30 + x cm; throwing lines inside; eroded.

No. 7: jar, Inv. No. C-1330 (2) [010]Uncoated | Nile B₂ | W₂ | W

Base fragment; round base. Wd: 1.00 cm; H₁: 6.50 + x cm; throwing lines inside; smoothed on the wheel. Another, Nile C₁, 1 base.

No. 8: jar, Inv. No. C-1330 (2) [011]Uncoated | Nile B₂ | W₂ | W

Base fragment; round base. Wd: 0.93 cm.; H₁: 5.53 + x cm; smoothed on the wheel. Another, 1 base.

No. 9: jar, Inv. No. C-1330 (3) [011]Uncoated | Nile B₂ | W₂ + Ha₂

Handle fragment; loop handle. H₁: 6.30 + x cm; Hd: 2.35 x 1.95 cm; eroded.

No. 10: storage jar (Fig. 36), Inv. No. C-1330 (3) [003]Uncoated | Nile B₂ | W₂

Rim sherd; inverted articulated interior and exterior rim, modelled lip. Rd: 28.00 cm 3/32; Wd: 1.20 cm; H₁: 4.90 + x cm; throwing lines inside; eroded.

No. 11: storage jar (Fig. 36), Inv. No. C-1330 (3) [001]Uncoated | Nile B₂ | W₂

Rim fragment; inverted articulated exterior rim. Rd: 20.00 cm 5/32; Wd: 1.00 cm; H₁: 7.20 + x cm; throwing lines inside; eroded. Another, Rd: 20.00 cm 3/32. Rd: 20.00 cm 3/32.

No. 12: storage jar (Fig. 36), Inv. No. C-1330 (2) [016]Uncoated | Nile B₂ | W₂

Rim sherd; everted direct rim. Rd: 30.00 cm 1/8; Wd: 1.20 cm; H₁: 4.00 + x cm; throwing lines inside; smoothed on the wheel.

No. 13: storage jar, Inv. No. C-1330 (2) [013]Uncoated | Nile B₂ | W₂ + Ha₂

Handle and wall fragment; inserted vertical loop handle. Wd: 2.20 cm; H₁: 26.00 + x cm; Hd: 3.65 x 2.40 cm; smoothed.

No. 14: storage jar, Inv. No. C-1330 (3) [012]Uncoated | Nile E₂ | Ha₂

Handle fragment; loop handle. Hd: 2.85 x 2.40 cm; eroded.

Pottery with special functions**No. 15: bakery tray** (Fig. 36), Inv. No. C-1330 (3) [008]Uncoated | Nile B₂ | W₁ | Ha

Complete, fragmentary; flat base; everted; direct rim. Rd: 18.00 cm 3/32; Bd: 16.00 cm; Wd: 1.20 cm; H₁: 3.90 cm; VI: 462; eroded.

No. 16: tray (Fig. 36), Inv. No. C-1330 (3) [010]Uncoated | Nile C₂ c. | Ha

Fragment. D: ca. 44.00 cm; Wd: 2.70 cm; H₁: 6.55 cm; eroded.

Body sherds, Nile B₂: 80 dm²; Nile C: 10 dm².

b) Imported pottery

Levantine household ware**No. 17: amphora** (Fig. 36), Inv. No. C-1311 (2) [005]Uncoated | IV.TG 08 | W₂Rim sherd; inverted direct rim. Rd: 12.00 cm; Wd: 0.80 cm; H₁: 2.00 + x cm. throwing lines inside; smoothed on the wheel.**No. 18: amphora**, IV.TG 11, body sherds, 0.10 dm².**No. 19: amphora**, IV.TG 18, body sherds, 0.10 dm².**No. 20: amphora**, IV.TG 24, body sherds, 0.30 dm².**No. 21: amphora**, IV.TG 32, body sherds, 0.10 dm².**No. 22: amphora**, IV.TG 51 (= TD IV.19), body sherds, 0.30 dm².**No. 23: amphora**, IV.TG 52 (= TD IV.19 c.), body sherds, 0.40 dm².**Cypriote household ware****No. 24: amphora**, VI.TG 40, body sherds, 0.10 dm².**II.- Finds****Object of unknown use****No. 25: fragment of an object**, Inv. F0744A. Bronze; 1.10 x 0.43 cm. *Find No. 005.***LEVEL IV: Building D****1.- General description**

Eastwards and close to Building C (in the west part of Area II, [Plan I](#)) there is a NE-SW-oriented mud brick building, Building D, whose plant forms an irregular rectangle of around 20 to 22 m, with a sort of niche or recess in the northwest angle ([Plans V and VI](#); [Plate IX](#)).³³ Exterior walls (or their respective foundations) are more than 2 m thick, delimiting ten rooms of the casemate type. The brickwork was carefully done, although some of the basal bricks are skew, most probably because they were placed before being thoroughly dry. The mud bricks are of two different qualities: clayish to the south and to the east and sandy to the north and to the west. This may have resulted from the simultaneous work of two squads that used bricks of different composition. On the base of one of the walls (**L1138**) the reused fragment of a 50 x 20 x 20 cm hewn limestone block - representing a painted bas-relief human figure in a boat, in a fluvial landscape - was placed as an architectural reinforcement. The figure, together with a cartridge identifying it, was chipped. This was a classic Egyptian solution to deliberately erase the memories of some anathematized character.

Only three rows of mud bricks are preserved and the floors have been eroded, turning it difficult to make further assumptions. On its remains there are numerous hearths which serve as testimony of subsequent occupations in the area ([Graphic II](#)).

2.- Archaeological material**L1138 (Fig. 37)****Finds****No. 1: reused relief** (Fig. 37), Inv. No. F0773A (Drawing No. 0392-0394). Fragmentary;

³³ There is a striking similarity between the layout of Building B and the one described by Gal and Alexandre, *Horbat Rosh Zayit. An Iron Age Storage Fort and Village*.

limestone; carved; 49.00 x 23.00 x 20.10 cm. Remains of a landscape scene: a painted relief with a human figure in a boat?; reused in the lower part of the wall L1138. *Find No. 001.*

LEVEL V: Upper layers

The remains of Building D were covered in unconformity by a dark, plastic layer very poor in archaeological remains. It was covered, again in unconformity, by the sandy topsoil.

AREA II, WEST SECTION

Sondages in the open spaces of Building C (L1008) (Plan V)

Abstract. Several test pits (= operations) dug into the casemates or open spaces of Building C (Plan V) provided independent stratigraphies, which are described from below to surface. They were intended to evaluate the archaeological potential of this part of the site and as a rule were too limited to allow an interpretation of the strata. Until substantial excavations are carried out, these sequence were divided into three levels: Level I.- pre-Building C, Level II.- Building C and Level III.- post-Building C.

Operation 25

This test pit was excavated in the space or casemate L1017 (Plan V), in northwestern Building C. It measured 2.20 x 1.10 m. (Graphic III)

Level	Locus	Description	Interpretation, comments
I	L1014a	Massive, clean sand. In its contact with the overlying strata it was somewhat darker owing to the presence of charcoal particles. In this part, the mud bricks of Building C were placed directly over this stratum.	Virgin soil, foundation sand or floor preparation
II	L1008	Building C	
III	L1013a	Plastic but richer in charcoal than overlying L1010. Abundant pottery but few faunal remains.	Human utilization, perhaps contemporary with Building C
	L1015a	Small combustion structure	
	L1010a	Light brown, very plastic, with charcoal in small particles and lenses. Four ash lenses were also identified. Both bones and pottery were in a very fragmentary condition (even pulverized). Some fallen and broken mud bricks.	The fallen bricks suggest that Building C was decaying
	L1011a	A narrow, curving gully which cut	

Level	Locus	Description	Interpretation, comments
III	L1011a	into L1010a. It was filled with the dark sediment of L1001.	
	L1001	Dark, very rich in pottery. 10 cm thick	Destruction layer
	Topsoil		

Archaeological material

L1001

See the archaeological material from this locus in p.319 and Fig. 58:1 to 58:17

L1008 (Fig. 38)

I.- Pottery

a) Egyptian pottery

Nile silt clay

Household ware

No. 1: bowl (Fig. 38:1), Inv. No. C-1016 [011]

Uncoated	Nile B ₂	W ₂
----------	---------------------	----------------

Rim sherd; everted direct rim. Rd: 20.00 cm 3/32; Wd: 0.70 cm; H₁: 1.15 + x cm; smoothed on the wheel. Others, Rd: 16.00 cm 1/4, Rd: 20.00 cm 1/32, Rd: 24.00 cm 3/32. Rd: 28.00 cm 3/32.

No. 2: bowl (Fig. 38:1), Inv. No. C-1016 [015]

Uncoated	Nile B ₂	W ₂
----------	---------------------	----------------

Rim sherd; everted articulated exterior rim. Rd: 18.00 cm 1/16; Wd: 0.63 cm; H₁: 2.87 + x cm; smoothed on the wheel.

No. 3: pilgrim flask (Fig. 38:1), Inv. No. P0393A (Drawing No. 0526)

Uncoated	Nile C ₁	W ₂ + Ha ₂	---	re.	2
----------	---------------------	----------------------------------	-----	-----	---

Neck and shoulder fragment. Nd: 3.00 cm 1/2; Md: 7.50 + x cm; Wd: 1.20 cm; H₁: 4.80 + x cm; H₃: 2.00 + x cm; Hd: 0.70 x 0.50 cm. Surface colour: 2.5YR 5/6 red. Break: 5YR 4/1 dark grey interior; 7.5YR 5/2 brown exterior. Technical details: throwing lines inside; three applied handles. Surface treatment: smoothed by hand.

No. 4: jar (Fig. 38:1), Inv. No. C-1016 [017]

Uncoated	Nile B ₂	W ₂
----------	---------------------	----------------

Rim sherd; vertical direct rim. Rd: 10.00 cm 3/32; Wd: 0.80 cm; H₁: 4.00 + x cm; throwing lines inside; smoothed on the wheel. Others, Rd: 10.00 cm 1/8, Rd: 12.00 cm 1/16.

No. 5: jar (Fig. 38:1), Inv. No. C-1016 [014]

Uncoated	Nile B ₂	W ₂
----------	---------------------	----------------

Rim sherd; vertical articulated exterior rim. Rd: 16.00 cm 3/32; Wd: 0.90 cm; H₁: 5.25 + x cm; throwing lines inside; smoothed on the wheel.

No. 6: jar (Fig. 38:1), Inv. No. C-1016 [009]

Uncoated	Nile B ₂	W ₂
----------	---------------------	----------------

Rim sherd; everted direct rim. Rd: 16.00 cm $\frac{3}{16}$; Wd: 0.78 cm; H₁: 4.00 + x cm; throwing lines inside; smoothed on the wheel. Another, Rd: 10.00 cm $\frac{1}{16}$.

No. 7: jar, Inv. No. C-1016 [005]

Uncoated	Nile B ₂	W ₂	base finished on the wheel	
----------	---------------------	----------------	----------------------------	--

Base and wall fragment; pointed base. Wd: 0.82-1.34 cm; H₁: 7.45 + x cm; throwing lines inside and outside; smoothed on the wheel.

No. 8: storage jar (Fig. 38:2), Inv. No. P0300A (Drawing No. 0290)

Uncoated	Nile E ₂	W ₂	---	ox.	2
----------	---------------------	----------------	-----	-----	---

Incomplete, fragmentary; rim and body fragment; swelling of the knob handle; globular type; articulated exterior rim, round lip. Rd: 29.00 cm $\frac{1}{2}$; Md: 42.00 cm; Wd: 0.75 cm; H₁: 62.00 + x cm; H₂: 24.00 + x cm; Hd: 4.80 x 2.80 cm. Surface colour: 5YR 6/3 light reddish brown. Break: 2.5YR 4/4 dusky red core; 2.5YR 4/3 dusky red oxidation zones. Technical details: throwing lines inside. Surface treatment: smoothed on the wheel.

No. 9: storage jar (Fig. 38:2), Inv. No. C-1016 [013]

Uncoated	Nile B ₂	W ₂
----------	---------------------	----------------

Rim sherd; inverted direct rim. Rd: 22.00 cm $\frac{3}{32}$; Wd: 1.40 cm; H₁: 4.20 + x cm throwing lines inside; smoothed on the wheel.

No. 10: storage jar (Fig. 38:2), Inv. No. C-1016 [003]

Uncoated	Nile B ₂	W ₂
----------	---------------------	----------------

Rim sherd; inverted articulated exterior rim. Rd: 22.00 cm $\frac{1}{4}$; Wd: 0.97 cm; H₁: 7.10 + x cm; throwing lines inside; smoothed on the wheel.

No. 11: storage jar (Fig. 38:2), Inv. No. C-1003 [001]

Uncoated	Nile B ₂	W ₂
----------	---------------------	----------------

Rim sherd; vertical direct rim. Rd: 30.00 cm $\frac{1}{32}$; Wd: 1.25 cm; H₁: 9.70 + x cm; eroded.

No. 12: storage jar (Fig. 38:2), Inv. No. C-1016 [020]

Uncoated	Nile B ₂	W ₂
----------	---------------------	----------------

Rim and handle fragment; loop handle; everted direct rim. Rd: 22.00 cm $\frac{1}{8}$; Wd: 0.80 cm; H₁: 5.28 + x cm; Hd: 2.25 x 1.54 cm; throwing lines inside; smoothed.

No. 13: storage jar, Inv. No. C-1016

Uncoated	Nile C ₁	W ₁
----------	---------------------	----------------

Wall fragment; Wd: 1.20 cm. Another, Wd: 1.30 cm.

Pottery with special functions

No. 14: bakery tray, Inv. No. C-1016 [002]

Uncoated	Nile C ₂	W ₁
----------	---------------------	----------------

Rim sherd; everted direct rim. Rd: 14.00 cm $\frac{3}{32}$; Wd: 1.80 cm; H₁: 2.90 + x cm; uneven.

No. 15: tray (Fig. 38:2), Inv. No. C-1016 [004]

Uncoated	Nile B ₂	Ha ₁
----------	---------------------	-----------------

Fragment. D: ca. 32 cm $\frac{1}{16}$; H₁: 2.48 cm. Another, $\frac{1}{4}$.

b) Imported pottery

Levantine household ware

No. 16: amphora, Inv. No. C-1016, IV.TG 23, body sherd: 0.10 dm².

No. 17: amphora, Inv. No. C-1016, IV.TG 53 (=TD IV.09), body sherd: 0.10 dm².

Aegean fine ware

Bichrome ware

No. 18: juglet (Fig. 38:2), Inv. No. P0382A (Drawing No. 0146)

WPBI	VIITG 39	W ₂	---	ox.	2
------	----------	----------------	-----	-----	---

Neck fragment. Nd: 1.85 cm; Wd: 0.30 cm; H₃: 1.20 + x cm. Surface colour: 7.5YR 8/4 pink. Break: 5YR 7/4 pink. Decoration: horizontally painted lines on the neck, 1 mm wide, 7.5YR 3/6 dark red and 2.5YR 2.5/1 reddish black. Surface treatment: polished, low lustre.

II.- Finds

Weight

No. 19: net weight (Fig. 38:2), Inv. No. F0234A (Drawing No. 0173). Complete, mended; limestone. 6.70 x 4.00 x 3.00 cm; oval shape; a stringing groove. Function: fishing.

Product

No. 20: pottery slag, Inv. No. F0361A.

L1010 (Fig. 39)

I.- Pottery

a) Egyptian pottery

Nile silt clay

Body sherds, Nile B₂, Nile C.

b) Imported pottery

Levantine household ware

No. 1: jar (Fig. 39), Inv. No. P0373A (Drawing No. 0145)

BP	IV.TG 01	W ₂	---	ox.	3
----	----------	----------------	-----	-----	---

Body sherd. Md: 14.00 cm; Wd: 0.45 cm; H₁: 3.17 + x cm. Surface colour: 7.5YR 6/4 light brown slip. Break: 7.5YR 6/4 light brown. Technical details: throwing lines inside. Surface treatment: polished, low lustre.

Phoenician fine ware

No. 2: juglet (Fig. 39), Inv. No. P0372A (Drawing No. 0146)

Uncoated?	IV.TG 37 = IV.Phoen?03	W ₂	---	ox.	3
-----------	------------------------	----------------	-----	-----	---

Base and wall fragment; flat base. Bd: 3.00 cm; Wd: 0.30 cm; H₁: 1.10 + x cm. Surface colour: ---. Break: ---. Surface treatment: ---. Smoked.

Aegean fine ware

No. 3: bowl (Fig. 39), Inv. No. P0370A (Drawing No. 0201)

RPMO	VII.TG 46	W ₂	---	ox.	3
------	-----------	----------------	-----	-----	---

Rim sherd; articulated exterior rim. Rd: 18.00 cm 5/32; Wd: 0.55 cm; H₁: 1.60 + x cm. Surface colour: 2.5YR 5/6 red slip. Break: 5YR 5/4 reddish brown. Decoration: a painted rim band on exterior and interior, 10R 4/4 weak red. Surface treatment: polished, medium lustre.

Black-on-Red III ware

No. 4: juglet (Fig. 39), Inv. No. P0369A (Drawing No. 0145)

BP[MO]	VII.TG 39	W ₂	---	ox.	3
--------	-----------	----------------	-----	-----	---

Body sherds (2). Md: 10.00 + x cm; Wd: 0.20 cm; H₁: 1.10-0.70 + x cm. Surface colour:

5YR 6/6 reddish brown slip. Break: 5YR 5/6 yellowish red. Decoration: ---. Surface treatment: polished, high lustre.

II.- Finds

Object of unknown use

No. 5: fragment of an object, Inv. No. F0027A. Bronze. 1.00 x 0.60 x 0.70 cm.

L1013

Egyptian pottery

Marl clay

Household ware

No. 3: amphora, Inv. No. P1158A

Uncoated	Marl F + limestone	Ha ₂ + W ₂	---	ox.	3
----------	--------------------	----------------------------------	-----	-----	---

Lower part of a handle and body fragment; oval in section; 1 [2]; single strap. Md: 22.00 cm; Hd: 2.90 x 1.50 cm. Surface colour: 2.5YR 7/2 light grey. Break: 10YR 6/3 pale brown. Technical details: throwing lines inside. Surface treatment: smoothed on the wheel.

L1014 (Fig. 40)

I.- Egyptian pottery

Nile silt clay

Household ware

No. 1 goblet (Fig. 40), Inv. No. P0046A (Drawing No. 0933)

Uncoated	Nile B ₂	W ₁	----	ox.	2
----------	---------------------	----------------	------	-----	---

Foot fragment. Fd: 4.10 cm 1/4; H₄: 3.50 + x cm. Surface colour: 2.5YR 6/6 light red. Break: 2.5YR 4/6 red. Surface treatment: smoothed on the wheel.

II.- Finds

Tool

No. 2: sharpener, Inv. No. F0810A. Complete; pumice. 4.10 x 2.40 x 2.00 cm.

Operation 26 (Plans XII and XIII)

This probe was opened in the space or casemate L1020 in the eastern part of Building C (Plan V; Plans XII and XIII). It measured approx. 1.10 x 2.30 m (Graphic IV).

Level	Locus	Description	Interpretation, comments
I	L1035	Yellowish sand with isolated charcoals in its upper limit. It turns clean and sterile as the excavation progresses. Pottery, few bones.	Virgin soil or foundation sand
	L1037	Hearth	
	L1032	Hearth	
	L1031	A finely stratified alternation of dark and light fill. The base is	

Level	Locus	Description	Interpretation, comments
I	L1031	clayey. This sediment fills two dark furrows.	
	L1030	Darker, more carbonaceous than L1031. It fills a long, narrow depression affecting L1031 and L1035. Inside this channel, non-metallic slag was found, and in the section, oxidation was noted in the contact of the channel with L1035.	The channel that drained fused matter and the associated nonmetallic slag indicates that a workshop area existed in this part of the site before the erection of Building C.
	L1016	Light brown, medium plastic, many charcoals. Perhaps the same layer as L1030.	
	L1013b	Similar to L1010b, but much more carbonaceous	
	1010b	Light brown, medium plastic. Charcoal, many bones.	
	Pits or ditch	At least two pits, or perhaps a ditch, were dug before the erection of this part of Building C.	It does not seem to be a foundation trench. Perhaps they were pits dug for the vertical posts of the scaffolding. More excavation is necessary in order to understand the function of this ditch.
II	L1008	Building C	
III	L1001	Many fish remains in its upper part.	Destruction layer
	Mortar	Clayey sediment (<i>muna</i>).	It seems to have formed from decayed mud bricks
	Topsoil		

Archaeological material

L1001

See the archaeological material from this locus in p.319 and Fig. 58:1 to 58:17

L1008

As L1008 is also located from the excavation made in the Operation 25, all the archaeological material was included there.

L1010

As L1010 were also located from the excavation made in the Operation 26, all the archaeological material was included there.

L1016 (Fig. 41)**Imported pottery***Aegean fine ware**Black-on-Red II? ware***No. 1: juglet (Fig. 41), Inv. No. P2002A** (Drawing No. 0435)

RPMO	VII.TG	45	W ₂	---	ox.	3
------	--------	----	----------------	-----	-----	---

Body sherd. Md: 10.20 cm; Wd: 0.20 cm; H₁: 2.00 + x cm. Surface colour: 2.5YR 6/8 light red slip. Break: 10R 6/6 light red interior; 10R 6/8 light red exterior. Technical details: throwing lines inside. Decoration: three vertically painted lines, 1 mm wide, 2.5YR 2.5/2 very dusky red. Surface treatment: polished, low lustre.

L1031 (Fig. 42)**Egyptian pottery****Nile silt clay***Pottery with special functions***No. 1: bakery tray (Fig. 42), Inv. No. P1059A** (Drawing No. 0434)

Uncoated	Nile B ₂	W ₁	Ha	ox.	2
----------	---------------------	----------------	----	-----	---

Complete, fragmentary. Rd: 20.00 cm 5/32; Bd: 18.00 cm 3/16; Wd: 1.25 cm; H₁: 4.90 cm. VI: 408. Surface colour: 5YR 6/4 light reddish brown. Break: 5YR 5/6 yellowish red. Surface treatment: smoothed. Observations: smoked on the rim (used as a lid?).

No. 2: bakery tray (Fig. 42), Inv. No. P1060A (Drawing No. 0433)

Uncoated	Nile B ₂	W ₁	Ha	ox.	2
----------	---------------------	----------------	----	-----	---

Complete, fragmentary. Rd: 20.00 cm 1/64; Bd: 18.00 cm 1/16; Wd: 1.40-1.50 cm; H₁: 4.60 cm. VI: 435. Surface colour: 5YR 6/3 light reddish brown. Break: 5YR 5/6 yellowish red. Surface treatment: smoothed. Observations: eroded.

II.- Finds*Suspended weight*

No. 3: loom weight?, Inv. No. F0036A. Fragmentary; limestone. 4.60 x 2.90 x 2.10 cm. Axial perforation. Find No. 001.

Product

No.4 : slag, Inv. No. F0794A.

Operations 32, 33, 34 and 35

Four test pits opened in the space or casemate L1018. in the north of Building C (Plan V), were adjacent and will be treated as a unity (Graphic V).

Level	Locus	Description	Interpretation, comments
I	L1060	Sand, with less archaeological remains than L1054. L1060 has been affected by channels or ditches which form a regular pattern. The mouth of a small, "black on red" jar. The handle is also decorated. Nearby, the base of a faience	The ditches may have been foundation trenches of light, flimsy structures.

Level	Locus	Description	Interpretation, comments
I	L1060	statuette.	
	L1056	Sand	
	L1055	A sedimentary lens rich in organic contents, charcoal and pottery	
	L1061	More plastic and less carbonaceous than L1043. Pottery and bones do not differ from those in L1043.	
II	L1008	Building C	
	L1054	Similar to overlying L1052 but with charcoals bigger and more abundant. Horizontal variations are considerable, perhaps because there are thin lenses that could not be differentiated in a sondage. There are no changes in the finds: pottery and faunal remains are scarce and very fragmentary.	
	L1053	Nondescript	
	L1052	See L1039	
	L1039	Oven and its corresponding drain. Its vault was formed with a kind of pottery 2 - 5 cm thick, with abundant vegetal remains as the only noted inclusion. The sediment in the interior of this combustion capsule was burnt. The runnel which drained the oven was clearly delimited by thick (even 4 cm) red sherds (of the same kind as the vault of the oven; some of them with a clear curvature, which others lack) disposed horizontally. It discharged towards S. Its interior contained oxidised particles, but no slag of any kind. But nearby, a vitrified, green-gray slag had been found. For this oven, a clayey base had been provided (L1052), in which only three mud bricks could be individualized. This base was no oxidized. Note: the walls of the oven L1039 and the very peculiar sherds associated to this fire feature were found scattered across several loci of the operation, an indication of some mixing of sediments. In part, this can be attributed to the pits excavated in antiquity in this place.	Industrial oven
	L1038	A narrow channel running E - W. Its	Part of an industrial oven

Level	Locus	Description	Interpretation, comments
II	<i>L1038</i>	fill is carbonaceous and ashy, with oxidised borders, indicating that some fused matter flowed along it. It was not bounded by sherds. Pulverized pottery in some spots. Fauna: few fish remains, calcined and very broken.	Part of an industrial oven
	<i>L1043</i>	More carbonaceous than overlying L1025. Pottery and bones are of the same kind but less abundant.	
III	L1026	Fallen mud bricks. The matrix is plastic and has few charcoals.	Debris from the decaying walls of L1008
	<i>L1025</i>	A defined archaeological unity, rich in artifacts and ecofacts (charcoal, fish and mammal bones), in contrast with overlying L1024. At the same time, it contains less charcoal and oxidised spots than L1043. Pottery sometimes pulverized. Several oxidized spots. An almost complete small reddish juglet (Inv. No. P0003A), with handle and perhaps slipped. It was plotted in the top plan.	
	<i>L1042</i>	A carbonaceous lens tipping markedly. Many horizontal differences are noted, but they do not justify the creation of independent loci.	
	<i>L1001</i>		Destruction layer
	<i>L1024</i>	Isolated charcoals. Some lenses of clay and fallen mud bricks. Pottery and faunal remains scarce. Bones are bigger than the mean of the site but more fragile than those in the carbonaceous loci.	Debris layer
	Topsoil		

Archaeological material

L1001

See the archaeological material from L1001 in p.319 and Fig. 58:1 to 58:17

L1008

As L1008 is also located from the excavation made in the Operation 25, all the archaeological material was included there.

L1024 (Fig. 43)**I.- Pottery****a) Egyptian pottery****Nile silt clay****Household ware****No. 1: bowl (Fig. 43), Inv. No. C-1163 [003]**Uncoated Nile B₂ W₂Rim sherd; everted direct rim. Rd: 34.00 cm 1/16; Wd: 0.80 cm; H₁: 2.70 + x cm; smoothed on the wheel.**No. 2: bowl (Fig. 43), Inv. No. C-1135 [003]**Uncoated Nile B₂ W₂Rim and wall fragment; everted articulated exterior rim, modelled lip. Rd: 18.00 cm 1/8; Wd: 1.00 cm; H₁: 5.35 + x cm; smoothed on the wheel.**No. 3: jar (Fig. 43), Inv. No. C-1163 [005]**Uncoated Nile B₂ W₂Rim sherd; inverted direct rim. Rd: 13.00 cm 1/16; Wd: 0.80 cm; H₁: 2.80 + x cm. Throwing lines inside; smoothed on the wheel; eroded.**No. 4: jar (Fig. 43), Inv. No. C-1163 [004]**Uncoated Nile B₂ W₂Rim sherd; inverted articulated exterior rim, rolled lip. Rd: 8.00 cm 1/8; Wd: 0.70 cm; H₁: 2.50 + x cm. Throwing lines inside; smoothed on the wheel.**No. 5: jar (Fig. 43), Inv. No. C-1135 [002]**Uncoated Nile B₂ W₂Rim and neck fragment; everted articulated exterior rim, round lip. Rd: 16.00 cm 1/8; Nd: 14.00 cm; Wd: 0.57 cm; H₁: 3.20 + x cm; throwing lines inside; smoothed on the wheel.**No. 6: storage jar (Fig. 43), Inv. No. C-1163 [001]**Uncoated Nile B₂ W₂Rim sherd; inverted articulated exterior rim, rolled lip. Rd: 24.00 cm 3/32; Wd: 1.20 cm; H₁: 4.80 + x cm. Throwing lines inside; smoothed on the wheel; salt incrustated.**No. 7: storage jar (Fig. 43), Inv. No. C-1135 (2) [001]**Uncoated Nile C₂ W₂Rim and wall fragment; inverted articulated exterior rim, round lip. Rd: 30.00 cm 5/32; Wd: 1.80 cm; H₁: 12.50 + x cm; throwing lines inside; smoothed on the wheel; eroded.**No. 8: storage jar Inv. No. C-1161 (2) [001]**Uncoated Nile B₂ W₂Rim sherd; everted direct rim, ledge trimmed lip. Rd: 20.00 cm 3/32; Nd: 18.00 cm 5/32; Wd: 1.00 cm; H₁: 4.80 + x cm; throwing lines inside; smoothed on the wheel.**No. 9: storage jar, Inv. No. C-1161 (2) [002]**Uncoated Nile B₂ Ha₂

Handle fragment; attached loop handle; Hd: 3.60 x 3.20 cm; smoothed.

Pottery with special functions**No. 10: lid** (Fig. 43), Inv. No. C-1135 [001]

Uncoated	Nile B ₂	W ₂
----------	---------------------	----------------

Rim sherd; everted articulated exterior rim, modelled lip. Rd: 24.00 cm 3/32; Wd: 0.62 cm; H₁: 4.10 + x cm; throwing lines inside; smoothed on the wheel; smoked inside. Another, Rd: 22.00 cm 1/8.

No. 11: "pigeon pot" (Fig. 43), Inv. No. C-1161 [001]

Uncoated	Nile B ₂	W ₂	W
----------	---------------------	----------------	---

Base fragment; Bd: 3.00 cm 5/32; Wd: 1.10 cm; H₁: 3.60 + x cm; throwing lines inside; smoothed on the wheel; eroded.

Body sherds, Nile B₂: 30.00 dm², Nile C₂ c., Marl A₄, Marl F + ochre.

b) Imported pottery**Levantine household ware****No. 12: amphora**, IV.TG 06, body sherds, 0.20 dm².**No. 13: amphora**, IV.TG 23, body sherds, 0.20 dm².**No. 14: amphora**, IV.TG 51 (=TD IV.19), body sherds, 0.10 dm².**No. 15: amphora**, IV.TG 52 (=TD IV.19 c.), body sherds, 0.10 dm².**Cypriote household ware****No. 16: amphora**, VI.TG 44, body sherds, 0.20 dm².**L1025 (Fig. 44)****I.- Pottery****Egyptian pottery****Nile silt clay****Egyptian fine ware****No. 1: juglet** (Fig. 44:1), Inv. No. P0003A (Drawing No. 0229)

RP	Nile E ₂	W ₂	W	ox.	2-3
----	---------------------	----------------	---	-----	-----

Incomplete; no rim preserved; bag-shaped type, round base. Nd: 3.70 cm; Md: 7.00 cm; Wd: 0.35 cm; H₁: 7.50 + x cm; H₂: 2.50 cm; H₃: 0.80 + x cm; Hd: 1.20 x 0.90 cm. Surface colour: 10R 4/6 red slip. Break: 5YR 6/6 reddish yellow. Technical details: sharp grooves inside; applied handle. Surface treatment: vertically burnished. *Find No. 001*.

No. 2: juglet (Fig. 44:1), Inv. No. P0002A (Drawing No. 0229)

RP	Nile E ₂	W ₂	W	ox.	2-3
----	---------------------	----------------	---	-----	-----

Incomplete; no rim preserved; bag-shaped type, round base. Nd: 3.80 cm; Md: 6.30 cm; Wd: 0.30 cm; H₁: 9.80 + x cm; H₂: 2.80 cm; H₃: 1.10 + x cm; Hd: 1.10 x 1.10 cm. Surface colour: 10R 5/6 red slip. Break: 5YR 6/6 reddish yellow. Technical details: sharp grooves inside; applied handle. Surface treatment: vertically burnished. *Find No. 002*.

Household ware**No. 3: bowl** (Fig. 44:1), Inv. No. C-1108 [004]

Uncoated	Nile B ₂	W ₂
----------	---------------------	----------------

Rim sherd; inverted direct rim, round lip. Rd: 22.00 cm 3/32; Wd: 0.80 cm; H₁: 5.60 + x cm; smoothed on the wheel; eroded. Another, Rd: 20.00 cm 1/4.

No. 4: bowl (Fig. 44:1), Inv. No. C-1143 [002]

Uncoated	Nile B ₂	W ₂
----------	---------------------	----------------

Rim sherd; inverted articulated exterior, flat lip. Rd: 22.00 cm $5/32$; Wd: 1.00 cm; H₁: 6.50 + x cm; smoothed on the wheel.

No. 5: bowl (Fig. 44:1), Inv. No. C-1143 [005]

Uncoated	Nile B ₂	W ₂
----------	---------------------	----------------

Rim sherd; everted articulated interior and exterior, trimmed lip. Rd: 24.00 cm $1/16$; Wd: 1.00 cm; H₁: 3.00 + x cm; smoothed on the wheel; eroded.

No. 6: bowl (Fig. 44:1), Inv. No. C-1134 [002]

Uncoated	Nile B ₂	W ₂
----------	---------------------	----------------

Rim sherd; everted rim, rolled lip. Rd: 28.00 cm $1/32$; Wd: 0.70 cm; H₁: 3.40 + x cm; smoothed on the wheel; eroded. Others, Rd: 18.00 cm $5/32$, Rd: 20.00 cm $3/3$, 2Rd: 32.00 cm $1/32$.

No. 7: bowl, Inv. No. C-1134 (6) [005]

Uncoated	Nile B ₂	W ₂	base finished on the wheel
----------	---------------------	----------------	----------------------------

Base fragment; ring base. Bd: 12.00 cm $3/16$; Wd: 1.40 cm; H₁: 3.50 cm; smoothed on the wheel; eroded. Another, Bd: 8.00 cm $1/4$.

No. 8: deep bowl (Fig. 44:2), Inv. No. C-1134 (3) [003]

Uncoated	Nile B ₂	W ₂
----------	---------------------	----------------

Rim sherd; everted direct rim. Rd: 12.00 cm $1/4$; Wd: 0.40 cm; H₁: 5.50 + x cm; throwing lines inside; smoothed on the wheel.

No. 9: cup (Fig. 44:2), Inv. No. C-1134 (3) [004]

Uncoated	Nile B ₂	W ₂
----------	---------------------	----------------

Rim sherd; inverted direct rim. Rd: 9.00 cm $3/64$; Wd: 0.35 cm; H₁: 6.00 + x cm; throwing lines inside; smoothed on the wheel.

No. 10: cooking pot, Inv. No. C-1134

Uncoated	Nile E ₂	W ₂
----------	---------------------	----------------

Body sherds; Wd: 0.80 cm; smoked.

No. 11: juglet (Fig. 44:2), Inv. No. C-1143 (3) [013]

RS	Nile B ₂	W ₂	W
----	---------------------	----------------	---

Body and base fragment; round base $1/4$. Md: 6.00 cm; Wd: 1.40 cm; H₁: 5.30 + x cm; throwing lines inside; smoothed.

No. 12: juglet, Inv. No. C-1143 [017]

Uncoated	Nile E ₂	Ha ₂
----------	---------------------	-----------------

Handle fragment; sticked loop handle; H₁: 4.00 + x cm; Hd: 1.10 x 0.60 cm; smoothed; eroded.

No. 13: jar (Fig. 44:2), Inv. No. C-1134 (5) [001]

Uncoated	Nile B ₂	W ₂
----------	---------------------	----------------

Rim sherd; inverted direct rim, round lip. Rd: 12.00 cm $3/32$; Wd: 0.60 cm; H₁: 3.00 + x cm; throwing lines inside; smoothed on the wheel; eroded. Others, Rd: 8.00 cm $1/8$, Rd: 9.00 cm $3/8$, Rd: 10.00 cm $3/32$.

No. 14: jar, Inv. No. C-1143 [001]

Uncoated	Nile B ₂	W ₂
----------	---------------------	----------------

Rim sherd; inverted articulated exterior, round lip. Rd: 16.00 cm $\frac{3}{32}$; Wd: 0.70 cm; H₁: 3.30 + x cm; throwing lines inside; smoothed on the wheel; eroded.

No. 15: jar, Inv. No. C-1143 [013]

Uncoated	Nile B ₂	W ₂
----------	---------------------	----------------

Rim sherd; inverted articulated exterior rim, modelled lip. Rd: 19.00 cm $\frac{3}{16}$; Wd: 0.80 cm; H₁: 4.00 + x cm. Throwing lines inside; smoothed on the wheel; eroded.

No. 16: jar (Fig. 44:2), Inv. No. C-1134 (6) [001]

Uncoated	Nile B ₂	W ₂
----------	---------------------	----------------

Rim sherd; vertical direct rim, round lip. Rd: 10.00 cm $\frac{1}{8}$; Wd: 0.50 cm; H₁: 2.40 cm; throwing lines inside; smoothed on the wheel. Others, Rd: 8.00 cm $\frac{5}{32}$, Rd: 9.00 cm $\frac{1}{4}$, Rd: 9.50 cm $\frac{15}{64}$, Rd: 10.00 cm $\frac{1}{8}$, Rd: 10.00 cm $\frac{7}{32}$, Rd: 11.00 cm $\frac{3}{32}$, Rd: 12.00 cm $\frac{3}{32}$, Rd: 13.00 cm $\frac{3}{32}$.

No. 17: jar (Fig. 44:2), Inv. No. C-1143 (3) [006]

Uncoated	Nile B ₂	W ₂
----------	---------------------	----------------

Rim sherd; everted direct rim. Rd: 10.00 cm $\frac{1}{16}$; Wd: 0.45 cm; H₁: 2.20 + x cm. Throwing lines inside; smoothed on the wheel. Others, Rd: 8.00 cm $\frac{3}{16}$, Rd: 8.00 cm $\frac{1}{4}$.

No. 18: jar (Fig. 44:2), Inv. No. C-1134 (6) [002]

Uncoated	Nile B ₂	W ₂
----------	---------------------	----------------

Rim sherd; everted direct rim, round lip. Rd: 16.00 cm $\frac{9}{64}$; Wd: 1.50 cm; H₁: 5.30 cm; throwing lines inside; smoothed on the wheel. Others, Rd: 10.00 cm $\frac{1}{8}$, Rd: 14.00 cm $\frac{3}{32}$.

No. 19: jar, Inv. No. C-1134 (6)

Uncoated	Nile E ₂	W ₂
----------	---------------------	----------------

Handle fragment; loop handle; Hd: 3.10 x 2.00 cm; very eroded. Others, Nile B₂, Hd: 2.80 x 2.30 cm.

No. 20: jar, Inv. No. C-1143 [003]

Uncoated	Nile B ₂	W ₂
----------	---------------------	----------------

Body fragment; incurved walls; Md: 10.00 cm $\frac{3}{16}$; Wd: 0.50 cm; H₁: 5.00 + x cm. Throwing lines inside; smoothed on the wheel; eroded.

No. 21: jar, Inv. No. C-1143 [018]

Uncoated	Nile B ₂	W ₂	W
----------	---------------------	----------------	---

Base fragment; round base; Wd: 0.80 cm; H₁: 1.50 + x cm. Throwing lines inside; smoothed on the wheel; eroded.

No. 22: jar, Inv. No. C-1143 [004]

Uncoated	Nile B ₂	W ₂	base finished on the wheel
----------	---------------------	----------------	----------------------------

Base fragment; pointed base; Wd: 0.40 cm; H₁: 5.00 + x cm. Throwing lines inside and outside; smoothed on the wheel; smoked. Others, 3 bases.

No. 23: jar (Fig. 44:2), Inv. No. C-1143 [004]

Uncoated	Nile B ₂	W ₂	base finished on the wheel
----------	---------------------	----------------	----------------------------

Base fragment; ring base, R₃; Md: 20.00 + x cm; Bd: 9.50 cm $\frac{1}{1}$; Wd: 1.10 cm; H₁: 7.80 + x cm. Throwing lines inside and outside; smoothed on the wheel.

No. 24: storage jar (Fig. 44:2), Inv. No. C-1134 (3) [002]Uncoated | Nile B₂ | W₂

Rim sherd; inverted direct rim, folded lip. Rd: 20.00 cm 3/32; Wd: 1.00 cm; H₁: 3.60 + x cm; throwing lines inside; smoothed on the wheel; eroded.

No. 25: storage jar (Fig. 44:2), Inv. No. C-1143 (3) [001]Uncoated | Nile B₂ | W₂

Rim sherd; inverted articulated exterior rim, modelled lip. Rd: 27.00 cm 7/64; Wd: 1.00 cm; H₁: 5.45 + x cm. Throwing lines inside; smoothed on the wheel; eroded. Another, Rd: 30.00 cm 1/16.

No. 26: storage jar (Fig. 44:3), Inv. No. C-1143 (7) [002]Uncoated | Nile C₁ | W₂

Rim sherd; inverted articulated exterior, round lip. Rd: 20.00 cm 3/16; Wd: 0.80 cm; H₁: 6.30 + x cm; throwing lines inside; smoothed on the wheel; eroded.

No. 27: storage jar, Inv. No. C-1143 [001]Uncoated | Nile B₂ | W₂

Rim sherd; inverted articulated interior and exterior rim, modelled lip. Rd: 48.00 cm 1/16; Wd: 0.80 cm; H₁: 4.00 + x cm. Throwing lines inside; smoothed on the wheel; eroded.

No. 28: storage jar (Fig. 44:3), Inv. No. C-1143 (3) [002]Uncoated | Nile B₂ | W₂

Rim sherd; vertical articulated interior and exterior rim, trimmed lip. Rd: 20.00 cm 9/64; Wd: 0.90 cm; H₁: 3.30 + x cm. Throwing lines inside; smoothed on the wheel.

No. 29: storage jar (Fig. 44:3), Inv. No. C-1134 [001]Uncoated | Nile B₂ | W₂

Rim and neck fragment; everted articulated exterior rim, flattened lip. Rd: 20.00 cm 1/8; Nd: 5.90 cm; Wd: 1.20 cm; H₁: 6.30 + x cm. Throwing lines inside; smoothed on the wheel; eroded.

No. 30: storage jar (Fig. 44:3), Inv. No. C-1134 (3) [001]Uncoated | Nile B₂ | W₂

Rim sherd; everted articulated exterior rim, round lip. Rd: 20.00 cm 3/32; Wd: 1.00 cm; H₁: 3.90 + x cm; throwing lines inside; smoothed on the wheel; eroded.

No. 31: amphora (Fig. 44:3), Inv. No. C-1143 (3) [005]Uncoated | Nile B₂ | W₂

Rim sherd; vertical direct rim. Rd: 9.00 cm 3/16; Wd: 0.50 cm; H₁: 3.50 + x cm. Throwing lines inside; smoothed on the wheel.

Pottery with special functions**No. 32: lid (Fig. 44:3), Inv. No. C-1143 (3) [008]**Uncoated | Nile B₂ | W₂

Rim sherd; everted direct rim. Rd: 20.00 cm 5/64; Wd: 0.80 cm; H₁: 1.40 + x cm. Throwing lines inside; smoothed on the wheel; smoked.

No. 33: bakery tray (Fig. 44:3), Inv. No. C-1134 [002bis]Uncoated | Nile B₂ | W₁ | Ha

Rim and base fragment; flat base, everted direct rim, round lip. Rd: 24.00 cm 3/16; Bd:

22.00 cm 5/32; Wd: 1.60 cm; H₁: 4.00 cm. VI: 600; finger prints outside; smoothed. Others (only rim), Nile C₂, Rd: 26.00 cm 3/32; another: eroded.

No. 34: "pigeon pot" (Fig. 44:3), Inv. No. C-1143 (3) [016]

Uncoated	Nile B ₂	W ₂	W
----------	---------------------	----------------	---

Base fragment. Md: 12.60 + x cm; Bd: 6.00 cm 1/2; Wd: 0.80 cm; H₁: 4.00 + x cm. Throwing lines inside; smoothed on the wheel.

Egyptian marls

Fine ware

No. 35: bowl, Inv. No. C-9048 [001]

P	Marl F	W ₂
---	--------	----------------

Rim and body sherd; incurved wall, everted direct rim, round lip. Rd: 14.00 cm 1/8; Wd: 0.60 cm; H₁: 5.39 + x cm; throwing lines outside; polished; eroded.

Household ware

No. 36: bowl, Inv. No. C-1143 [001]

Uncoated	Marl F	W ₂
----------	--------	----------------

Rim sherd; everted articulated exterior rim, flattened lip. Rd: 24.00 cm 1/32; Wd: 0.55 cm; H₁: 1.70 + x cm. Throwing lines inside; smoothed on the wheel; eroded.

No. 37: cup, Inv. No. C-1143 [006]

Uncoated	Marl F	W ₂
----------	--------	----------------

Rim sherd; convex side body; everted rim direct rim. Rd: 10.00 cm 7/32; Wd: 0.35 cm; H₁: 3.50 + x cm. Throwing lines inside; smoothed on the wheel; eroded.

No. 38: amphora, Inv. No. C-1134 (6) [003]

Uncoated	Marl F	W ₂
----------	--------	----------------

Rim sherd; vertical direct rim, round lip. Rd: 8.00 cm 5/32; Wd: 0.80 cm; H₁: 3.40 cm; throwing lines inside; smoothed on the wheel; eroded.

No. 39: amphora, Inv. No. C-1134 (6) [008]

Uncoated	Marl F + ochre	W ₂
----------	----------------	----------------

Handle fragment; loop handle; Hd: 3.10 x 2.10 cm. Another, Hd: 3.00 x 2.00 cm.

Body sherds, Nile B₂: 45.00 dm²; Nile C₁: 3.00 dm²; Nile C₂: 10.00 dm²; Nile C₂ c.: 2.00 dm²; Marl A₄, Marl F, Marl F v.s., Marl F + ochre.

b) North Sinai/Sout Palestine pottery

Household ware

No. 40: amphora, Inv. No. C-1134 (3), II.TG 09, body sherds.

c) Imported pottery

Levantine household ware

No. 41: amphora, IV.TG 03, body sherds: 0.40 dm².

No. 42: amphora, IV.TG 07, body sherds: 0.10 dm².

No. 43: amphora, IV.TG 11, body sherds: 0.10 dm².

No. 44: amphora, IV.TG 18, body sherds: 0.10 dm².

No. 45: amphora, Inv. No. C-1143 [021]

Uncoated	IV.TG 23	Ha ₂
----------	----------	-----------------

Handle fragment; sticked loop handle; Hd: 2.20 x 1.20 cm; smoothed by hand; eroded.

No. 46: amphora, IV.TG 23, body sherds: 0.10 dm².

No. 47: amphora, IV.TG 24, body sherds: 0.10 dm².

No. 48: amphora, similar to IV.TG 24, body sherds: 0.10 dm².

No. 49: amphora, IV.TG 29, body sherds: 0.10 dm².

No. 50: amphora, IV.TG 51 (=TD IV.19), body sherds: 0.10 dm².

No. 51: amphora, IV.TG 53 (=TD IV.09), body sherds: 0.10 dm².

Cypriote fine ware

White Painted II ware

No. 52: juglet (Fig. 44: 3), Inv. No. P0705A (Drawing No. 0398)

WPMO	VI.TG 40	W ₂	---	med.	2-3
------	----------	----------------	-----	------	-----

Body sherd. Md: 5.50 + x cm; Wd: 0.40 cm; H₁: 1.00 + x cm. Surface colour: 10YR 7/4 very pale yellow slip. Break: 10YR 4/1 dark grey core; 10YR 6/3 pale brown oxidation ones. Technical details: throwing lines inside. Decoration: horizontally and oblique painted lines, 1 cm wide, 10YR 2/1 black. Surface treatment: polished, low lustre.

White Painted IV ware?

No. 53: jar (Fig. 44:3), Inv. No. P0695A (Drawing No. 0310)

BPMO	VI.TG 40	W ₂	---	ox.	3
------	----------	----------------	-----	-----	---

Body sherd. Md: 20.00 + x cm; Wd: 0.40 cm; H₁: 2.50 + x cm. Surface colour: 10YR 5/4 light yellowish brown slip. Break: 10YR 6/4 light yellowish brown. Technical details: throwing lines inside. Decoration: horizontally and oblique painted lines, 1 and 5 mm wide, 10YR 2/3 very dark brown. Surface treatment: polished, low lustre. *Find No. 005.*

White Painted ware?

No. 54: jar (Fig. 44:3), Inv. No. P1043A (Drawing No. 0398)

WP[MO]	VI.TG 04	W ₂	H	ox.	3
--------	----------	----------------	---	-----	---

Base fragment; ring base (R₂). Bd: 6.00 cm ½; Wd: 0.60 cm; H₁: 2.50 + x cm. Surface colour: 7.5YR 8/6 reddish yellow slip. Break: 7.5YR 7/6 reddish yellow. Technical details: throwing lines inside. Surface treatment: polished, low lustre.

Cypriote household ware

No. 55: amphora, VI.TG 04, body sherds.

No. 56: amphora, VI.TG 40, body sherds.

No. 57: amphora, VI.TG 49, body sherds.

Aegean fine ware

Black-on-Red II ware

No. 58: juglet (Fig. 44:4), Inv. No. P0707A (Drawing No. 0306)

RPMO	VII.TG 39	W ₂	---	ox.	3
------	-----------	----------------	-----	-----	---

Rim and neck fragment; everted direct rim. Rd: 3.00 cm ¾; Nd: 1.00 cm; Wd: 0.35 cm; H₃: 1.40 + x cm. Surface colour: 2.5YR 7/6-6/6 light red. Break: 2.5YR 6/6 light red. Technical details: throwing lines inside. Decoration: horizontally painted lines on the rim and neck, 1 and 3 mm wide, 2.5YR 3/1 dark reddish grey. Surface treatment: polished.

No. 59: juglet (Fig. 44:4), Inv. No. P0694A (Drawing No. 0306)

RPMO	VII.TG 45	W ₂	---	ox.	3
------	-----------	----------------	-----	-----	---

Rim, neck and handle fragment; compound neck, everted direct rim. Rd: 4.10 cm; Nd: 1.30-1.80 cm; Wd: 0.35 cm; H₃: 3.80 + x cm; Hd: 0.60 x 0.70 cm. Surface colour: 5YR 6/6

reddish yellow slip. Break: 5YR 6/4 light reddish brown. Decoration: horizontally painted lines, 1.5-5.4 mm wide, on the rim and neck; vertically and horizontally on the handle; colour: 5YR 4/2 dark reddish grey. Surface treatment: polished, medium lustre. *Find No. 005.*

Black-on-Red III ware

No. 60: juglet (Fig. 44:4), Inv. No. P0708A (Drawing No. 0397)

RPMO	VII. TG 45	W ₂ + Ha	---	ox.	3
------	------------	---------------------	-----	-----	---

Neck fragment and swelling of the handle; compound neck. Nd: 1.30-1.70 cm; Wd: 0.35 cm; H₃: 2.20 + x cm. Surface colour: 5YR 6/3 light reddish brown slip. Break: 5YR 5/4 reddish brown. Decoration: horizontally painted lines, 2 mm wide, 5YR 4/2 dark reddish grey. Surface treatment: polished, low lustre.

II.- Finds

Tool

No. 61: grinding stone? (Fig. 44:4), Inv. No. F0228A (Drawing No. 0908). Complete; quartzite? 4.00 x 4.24 x 4.00 cm; colour: 7.5YR 7/2 pinkish grey. Cubic shape; used also for grinding pigments? *Find No. 001.*

Product

No. 62: faience slag, Inv. No. F0787A.

No. 63: slag, Inv. No. F0786A.

L1038 (Fig. 45)

I.- Pottery

Egyptian pottery

Nile silt clay

Household ware

No. 1: bowl (Fig. 45), Inv. No. C-1133 [003]

Uncoated	Nile B ₂	W ₂
----------	---------------------	----------------

Rim and body sherd; inverted direct rim, trimmed lip. Rd: 22.00 cm 3/32; Wd: 0.75 cm; H₁: 3.70 + x cm; smoothed inside; eroded outside.

No. 2: jar (Fig. 45), Inv. No. C-1133 [001]

Uncoated	Nile B ₂	W ₂
----------	---------------------	----------------

Rim and body sherd; inverted direct rim, round lip. Rd: 12.00 cm 3/32; Wd: 0.55 cm; H₁: 4.50 + x cm; throwing lines inside; smoothed on the wheel.

No. 3: jar (Fig. 45), Inv. No. C-1133 [002]

Uncoated	Nile B ₂	W ₂
----------	---------------------	----------------

Rim and body sherd; everted direct rim, round lip. Rd: 12.00 cm 1/8; Wd: 0.55 cm; H₁: 2.80 + x cm; throwing lines inside; smoothed on the wheel; eroded.

No. 4: storage jar (Fig. 45), Inv. No. C-1133 [004]

Uncoated	Nile B ₂	W ₂
----------	---------------------	----------------

Rim and body sherd; inverted articulated interior and exterior rim. Rd: 20.00 cm 1/16; Wd: 0.80 cm; H₁: 3.70 + x cm; throwing lines inside; smoothed on the wheel; eroded.

L1039 (Fig. 46)**I.- Pottery****Egyptian pottery****Nile silt clay****Household ware****No. 1: bowl (Fig. 46), Inv. No. C-1136 [002]**Uncoated | Nile B₂ | W₂Rim sherd; convex sided walls; everted articulated exterior rim, trimmed lip. Rd: 29.00 cm 3/64; Wd: 0.70 cm; H₁: 4.70 + x cm; throwing lines in side; smoothed on the wheel.**No. 2: bowl (Fig. 46), Inv. No. C-1136 [001]**Uncoated | Nile B₂ | W₂Rim sherd; convex sided walls; everted articulated exterior rim, pendant lip. Rd: 24.00 cm 5/32; Wd: 0.80 cm; H₁: 5.50 + x cm; throwing lines in side; smoothed on the wheel.**No. 3: jar, Inv. No. C-1159 [003]**Uncoated | Nile B₂ | W₂ | base finished on the wheel

Base fragment; pointed base; Wd: 0.78 cm; very eroded.

No. 4: storage jar, Inv. No. C-1159Uncoated | Nile B₂ | W₂

Rim sherd; everted direct rim. Rd: 24.00 cm 3/32; Wd: 0.77 cm; very eroded.

No. 5: storage jar, Inv. No. C-1159 [001]Uncoated | Nile C₂ | W₂Rim and body sherd; everted articulated exterior, round lip. Rd: 24.00 cm 1/8; Wd: 1.44-2.27 cm; H₁: 9.20 + x cm; smoothed on the wheel; undulated interior walls.**Body sherds, Nile B₂: 20.00 dm²; Nile C₂: 14.00 dm².****b) North Sinai/South Palestine pottery****Household ware****No. 6: amphora, II.TG 10, body sherds, 0.20 dm².****c) Imported pottery****Cypriote fine ware****No. 7: juglet (Fig. 46), Inv. No. P2010A (Drawing No. 0444)**WP | VI.TG 42 | W₂ | --- | me. | 3Body sherd. Md: ca. 8.50 cm; Wd: 0.40 cm; H₁: 2.00 + x cm. Surface colour: 2.5Y 8/2 pale yellow slip. Break: 10R 3 /1 dark reddish grey core; 7.5YR 7/6 reddish yellow oxidation zones. Technical details: throwing lines inside. Surface treatment: polished, high lustre.**II.- Finds****Object of unknown use****No. 8: fragment of an object, Inv. No. F0304A. Clay; hand-made. 3.00 x 3.30 x 1.70 cm; colour: 2.5YR 4/3 (reddish brown).****Product****No. 9: faience slag, Inv. No. F0774A.**

L1043 (Fig. 47)**I.- Pottery****a) Egyptian pottery****Nile silt clay****Household ware****No. 1: bowl (Fig. 47:1), Inv. No. C-1101 [001]**Uncoated Nile B₂ W₂Rim sherd; incurved wall, inverted direct rim, flattened lip. Rd: 22.00 cm 1/16 + 1/16; Wd: 0.65 cm; H₁: 3.20 + x cm; smoothed on the wheel; eroded.**No. 2: bowl (Fig. 47:1), Inv. No. C-1101 [003]**Uncoated Nile B₂ W₂Rim sherd; incurved wall, inverted articulated interior and exterior, flattened lip. Rd: 22.00 cm 3/32; Wd: 0.70 cm; H₁: 3.70 + x cm; smoothed on the wheel; eroded.**No. 3: bowl, Inv. No. C-1116 (2)**Uncoated Nile B₂ W₂

Rim sherd; everted articulated exterior, round lip. Rd: 26.00 cm 1/16; very eroded.

No. 4: jar (Fig. 47:1), Inv. No. C-1101(2) [003]Uncoated Nile B₂ W₂Rim sherd; inverted direct rim. Rd: 12.00 cm 3/32; Wd: 0.50 cm; H₁: 3.50 + x cm. Throwing lines inside; smoothed on the wheel. Others, Rd: 10.00 cm 3/32, Rd: 12.00 cm 1/16.**No. 5: jar (Fig. 47:1), Inv. No. C-1101 (2) [005]**Uncoated Nile B₂ W₂Rim sherd; everted direct rim. Rd: 8.00 cm 3/32; Wd: 0.70 cm; H₁: 2.00 + x cm. Throwing lines inside; smoothed on the wheel. Others, Rd: 14.00 cm 1/16 Rd: 15.00 cm 1/16.**No. 6: jar (Fig. 47:1), Inv. No. C-1101 (2) [004]**Uncoated Nile B₂ W₂Rim sherd; vertical direct rim, round lip. Rd: 12.00 cm 3/32; Wd: 0.45 cm; H₁: 3.40 + x cm; throwing lines inside; smoothed on the wheel; eroded. Others, Rd: 12.00 cm 1/8, Rd: 18.00 cm 1/16.**No. 7: jar, Inv. No. C-1101 [007]**Uncoated Nile B₂ W₂ WBase fragment; round base; Wd: 0.80 cm; H₁: 3.00 + x cm. Throwing lines inside; smoothed on the wheel.**No. 8: jar, Inv. No. C-1101 (3) [006]**RS Nile B₂ W₂ base finished on the wheelBase and wall fragment; ring base (R₃). Bd: 8.00 cm 1/3; Wd: 0.60 cm; H₁: 5.10 + x cm; . throwing lines inside; red slip; smoothed on the wheel.**No. 9: jar, Inv. No. C-1116 [002]**Uncoated Nile C₁ W₂ base finished on the wheelBase fragment; pointed base. Wd: 0.50 cm; H₁: 3.50 + x cm; smoothed on the wheel; eroded.

No. 10: jar, Inv. No. C-1116 [002]Uncoated Nile B₂ Ha₂

Handle fragment; Hd: 3.15 x 2.30 cm; smoothed. Others, Hd: 3.10 x 2.55 cm. Hd: 3.30 x 2.50 cm.

No. 11: storage jar, Inv. No. C-1116 [001]Uncoated Nile C₁ W₂Rim sherd; inverted articulated exterior rim, rolled lip. Rd: 30.00 cm 1/8; Wd: 0.70 cm; H₁: 4.60 + x cm; throwing lines inside; smoothed on the wheel; eroded.**No. 12: storage jar** (Fig. 47:1), Inv. No. C-1101 (3) [002]Uncoated Nile B₂ W₂Rim sherd; slightly inverted articulated exterior, modelled lip. Rd: 30.00 cm 1/16; Wd: 1.00 cm; H₁: 3.60 + x cm; throwing lines inside; smoothed on the wheel.**No. 13: storage jar** (Fig. 47:1), Inv. No. C-1101 (3) [001]Uncoated Nile B₂ W₂Rim sherd; vertical articulated exterior, round lip. Rd: 22.00 cm 1/8; Wd: 0.80 cm; H₁: 3.80 + x cm; throwing lines inside; smoothed on the wheel.**No. 14: storage jar** (Fig. 47:1), Inv. No. C-1101 (3) [003]Uncoated Nile B₂ W₂Rim sherd; everted articulated exterior, round lip. Rd: 28.00 cm 1/16; Wd: 0.60 cm; H₁: 4.75 + x cm; throwing lines inside; smoothed on the wheel.**Pottery with special functions****No. 15: lid** (Fig. 47:1), Inv. No. C-1116 [001]Uncoated Nile B₂ W₂Rim sherd; everted direct rim, round lip. Rd: 20.00 cm 1/16; Wd: 0.80 cm; H₁: 3.00 + x cm; smoothed on the wheel; eroded and smoked. Another, Rd: 16.00 cm 3/32.**No. 16: bakery tray** (Fig. 47:1), Inv. No. P1073A (Drawing No. 0396)Uncoated Nile C₂ W₁ Ha me. 2Complete, fragmentary. Rd: 26.00 cm 3/32; Wd: 1.20 cm; Bd: 24.00 cm 3/32; H₁: 6.00 cm. VI: 433. Surface colour: 5YR 5/4 reddish brown. Break: 5YR 6/3 light reddish brown. Surface treatment: smoothed. Observations: eroded on the base.**Egyptian marls****Household ware****No. 17: jar** (Fig. 47:1), Inv. No. C-1101 [006]Uncoated Marl F v.s. W₂Rim sherd; everted direct rim, round lip. Rd: 12.00 cm 5/32; Wd: 1.00 cm; H₁: 2.90 + x cm; throwing lines inside; smoothed on the wheel; eroded.**No. 18: amphora**, Inv. No. C-1101 (3) [005]Uncoated Marl F Ha₂ + W₂Handle and wall fragment; attached vertical loop handle; Wd: 0.70 cm; H₁: 4.60 + x cm; Hd: 2.70 x 1.60 cm; smoothed; eroded.**Body sherds**, Nile B₂: 40 dm²; Nile C₂: 10 dm²; Marl A₄, Marl F, Marl F s., Marl F + ochre.

b) North Sinai/South Palestine pottery**Household ware****No. 19: jar** (Fig. 47:1), Inv. No. C-1101 [005]Uncoated | II.TG 09 | W₂Base and wall fragment; ring base (R₃); Bd: 6.00 cm; Wd: 1.20 cm; H₁: 3.50 + x cm; throwing lines inside; smoothed on the wheel; eroded.**No. 20: amphora** (Fig. 47:2), Inv. No. C-1101 (3) [004]Uncoated | II.TG 09 | W₂Rim sherd; vertical direct rim, round lip. Rd: 10.00 cm 5/23; Wd: 0.70 cm; H₁: 2.70 + x cm; throwing lines inside; smoothed on the wheel; eroded.**No. 21: amphora**, II.TG 09, body sherds.**No. 22: amphora**, II.TG 10, body sherds.**No. 23: amphora**, II.TG 59, body sherds.**c) Imported pottery****Levantine household ware****No. 24: amphora?** (Fig. 47:2), Inv. No. C-1101 [002]Uncoated | IV.TG 11 | W₂Rim sherd; inverted direct rim, round lip. Rd: 10.00 cm 3/16; Wd: 0.70 cm; H₁: 3.60 + x cm; throwing lines inside; smoothed on the wheel; eroded.**No. 25: amphora**, IV.TG 18, body sherds.**No. 26: amphora**, IV.TG 23, body sherds.**Aegean household ware.****No. 31: amphora**, VII.TG 39, body sherds.**II.- Finds****Religion****No. 27: wdjat** (Plate 2), Inv. No. F0251. Complete; carnelian. 1.20 cm x 1.60 cm x 0.40 cm; colour: 2.5YR 6/4 light reddish brown; darker part: 2.5YR 5/8 red. Description: right eye, sketched shape and details, very simplified, a hole in the internal panel of the curved lower arc, a darker longitudinal spot suggests the pupil and sclera. Observations: fine quality. SCA No.1041. *Find No. 004.***Product****No. 28: metal slag**, Inv. No. F0825A.**No. 29: metal slag**, Inv. No. F0332A.**Raw material****No. 30: stone**, Inv. No. F0823A. 4.50 x 1.90 x 2.30 cm.**L1054 (Fig. 48)****I.- Pottery****a) Egyptian pottery****Nile silt clay****Household ware****No. 1: bowl** (Fig. 48:1), Inv. No. C-1185 [007]

Uncoated	Nile B ₂	W ₂
----------	---------------------	----------------

Rim sherd; inverted direct rim, flat lip. Rd: 18.00 cm 3/16; Wd: 0.80 cm; H₁: 3.40 + x cm; smoothed on the wheel.

No. 2: bowl (Fig. 48:1), Inv. No. C-1150 [004]

Uncoated	Nile B ₂	W ₂
----------	---------------------	----------------

Rim sherd; everted direct rim, flattened lip. Rd: 26.00 cm 3/64; Wd: 0.90 cm; H₁: 3.30 + x cm; smoothed on the wheel.

No. 3: bowl (Fig. 48:1), Inv. No. C-1150 [003]

Uncoated	Nile B ₂	W ₂
----------	---------------------	----------------

Rim sherd; everted direct rim, round lip. Rd: 34.00 cm 3/64; Wd: 0.75 cm; H₁: 3.00 + x cm; smoothed on the wheel.

No. 4: bowl, Inv. No. C-1185 [012]

Uncoated	Nile B ₂	W ₂	base finished on the wheel
----------	---------------------	----------------	----------------------------

Base and wall fragment; ring base (R₃). Bd: 9.00 cm 1/3; Wd: 1.30 cm; H₁: 4.40 + x cm; eroded.

No. 5: cup or deep bowl? Inv. No. C-1150 [009]

Uncoated	Nile B ₂	W ₂	W
----------	---------------------	----------------	---

Base fragment; round base; Md: 7.00 + x cm; Wd: 0.45 cm; H₁: 3.30 + x cm; throwing lines inside and outside; smoothed on the wheel.

No. 6: jar (Fig. 48:1), Inv. No. C-1185 [004]

Uncoated	Nile B ₂	W ₂
----------	---------------------	----------------

Rim and body sherd; inverted articulated exterior, round lip. Rd: 11.00 cm 1/8; Wd: 1.00 cm; H₁: 6.70 + x cm; throwing lines inside; smoothed on the wheel.

No. 7: jar (Fig. 48:1), Inv. No. C-1185 [001]

Uncoated	Nile B ₂	W ₂
----------	---------------------	----------------

Rim and body sherd; vertical direct rim, round lip. Rd: 13.00 cm 7/32; Wd: 0.45 cm; H₁: 3.90 + x cm; throwing lines inside; smoothed on the wheel. Others, Rd: 9.00 cm 1/8, Rd: 10.00 cm 1/8, Rd: 11.00 cm 1/8, eroded, Rd: 15.00 cm 1/8.

No. 8: jar (Fig. 48:1), Inv. No. C-1160 [009]

Uncoated	Nile B ₂	W ₂
----------	---------------------	----------------

Rim and body sherd; vertical articulated exterior, round lip. Rd: 12.00 cm 5/32; Wd: 0.90 cm; H₁: 4.28 + x cm; throwing lines inside; smoothed on the wheel.

No. 9: jar, Inv. No. C-1160 [007]

Uncoated	Nile B ₂	W ₂
----------	---------------------	----------------

Rim and body sherd; everted direct rim, round lip. Rd: 16.00 cm 1/8; Wd: 0.86 cm; H₁: 4.62 + x cm; throwing lines inside; smoothed on the wheel; eroded.

No. 10: jar, Inv. No. C-1185 [010]

Uncoated	Nile B ₂	Ha ₂ + W ₂
----------	---------------------	----------------------------------

Handle and wall fragment; attached vertical loop handle body to body. Wd: 0.80 cm; H₁: 7.00 + x cm; Hd: 2.70 x 2.60 cm; smoothed on the wheel.

No. 11: jar, Inv. No. C-1185 [013]

Uncoated	Nile B ₂	W ₂	base finished on the wheel
----------	---------------------	----------------	----------------------------

Base and wall fragment; pointed base; Wd: 0.90 cm; H₁: 4.90 + x cm; throwing lines inside; fingers marks inside; smoothed on the wheel.

No. 12: jar, Inv. No. C-1160

Uncoated	Nile B ₂	W ₂	W
----------	---------------------	----------------	---

Base fragment; round base; Wd: 0.85 cm.

No. 13: storage jar (Fig. 48:1), Inv. No. C-1150 [006]

Uncoated	Nile B ₂	W ₂
----------	---------------------	----------------

Rim sherd and swelling of the handle; inverted direct rim, round lip. Rd: 28.00 cm 1/16; Wd: 0.90 cm; H₁: 5.80 + x cm; throwing lines inside; smoothed on the wheel; eroded.

No. 14: storage jar (Fig. 48:1), Inv. No. C-1160 [008]

Uncoated	Nile B ₂	W ₂
----------	---------------------	----------------

Rim and body sherd; undulated interior wall, inverted direct rim, round lip. Rd: 24.00 cm 1/8; Wd: 0.97 cm; H₁: 8.30 + x cm; throwing lines inside; smoothed on the wheel. Another, Rd: 23.00 cm 1/8.

No. 15: storage jar (Fig. 48:1), Inv. No. C-1185 [003]

Uncoated	Nile B ₂	W ₂
----------	---------------------	----------------

Rim and body sherd; vertical direct rim, round lip. Rd: 24.00 cm 3/32; Wd: 0.70 cm; H₁: 4.00 + x cm; throwing lines inside; smoothed on the wheel.

No. 16: storage jar (Fig. 48:2), Inv. No. C-1185 [002]

Uncoated	Nile B ₂	W ₂
----------	---------------------	----------------

Rim and body sherd; vertical articulated interior and exterior, symmetric lip. Rd: 24.00 cm 3/16; Wd: 0.70 cm; H₁: 5.50 + x cm; throwing lines inside; smoothed on the wheel; eroded.

No. 17: storage jar, Inv. No. C-1185 [016]

Uncoated	Nile B ₂	W ₂
----------	---------------------	----------------

Rim sherd; vertical articulated interior and exterior, symmetric lip. Rd: 26.00 cm 1/8; eroded.

No. 18: storage jar (Fig. 48:2), Inv. No. C-1150 [001]

Uncoated	Nile B ₂	W ₂
----------	---------------------	----------------

Rim sherd; vertical articulated exterior, round lip. Rd: 20.00 cm 3/64; Wd: 0.90 cm; H₁: 3.00 + x cm; throwing lines inside; smoothed on the wheel.

No. 19: storage jar, Inv. No. C-1160 [003]

Uncoated	Nile B ₂	Ha ₂ + W ₂
----------	---------------------	----------------------------------

Handle and wall fragment; attached vertical loop handle; Wd: 1.77 cm; H₁: 8.60 + x cm; Hd: 4.20 x 3.90 cm; smoothed.

Pottery with special functions

No. 20: tray (Fig. 48:2), Inv. No. C-1160 [001]

Uncoated	Nile C ₂	Ha ₁
----------	---------------------	-----------------

Fragment; D: ca. 45.00 cm; Wd: 2.50 cm; H₁: 6.20 cm; eroded.

Egyptian marls

Household ware

No. 21: bowl (Fig. 48:2), Inv. No. C-1160 [010]Uncoated | Marl F | W₂Rim and body sherd; everted direct rim, round lip. Rd: 14.00 cm 1/16; Wd: 0.54 cm; H₁: 6.32 + x cm; throwing lines inside; smoothed on the wheel.**No. 22: juglet**, Inv. No. C-1185 [011]Uncoated | Marl F v.s. | Ha₂

Handle fragment; loop handle; Hd: 1.35 x 1.35 cm; eroded.

No. 23: amphora, Inv. No. C-1185Uncoated | Marl F v.s. | Ha₂

Handle fragment. Hd: 3.10 x 2.10 cm Hd: 2.70 x 2.10 cm; smoothed. Others, Hd: 4.10 x 2.10 cm, Hd: 3.30 x 1.80 cm.

Body sherds, Marl F, Marl F v.s, Marl F + ochre.**b) North Sinai/South Palestine pottery****Household ware****No. 24: amphora**, Inv. No. C-1160 [006]Uncoated | II.TG 09 | Ha₂

Handle fragment; attached vertical loop handle; Hd: 2.30 x 2.00 cm; smoothed.

No. 25: amphora (Fig. 48:2), Inv. No. C-1150 [005]Uncoated | II.TG 10 | W₂Rim sherd; vertical direct rim, round lip. Rd: 10.00 cm 3/16; Wd: 0.50 cm; H₁: 2.50 + x cm; throwing lines inside; smoothed on the wheel. Handle (from another amphora?), Hd: 2.70 x 2.00 cm.**No. 26: amphora**, Inv. No. C-1185, II.TG 10, body sherds.**No. 27: amphora**, Inv. No. C-1185, II?.TG 59, body sherds.**c) Imported pottery****Levantine household ware****No. 28: amphora** (Fig. 48:2), Inv. No. C-1150 [008]Uncoated | IV.TG 28 | W₂Shoulder fragment; Md: ca. 25.00 cm on the shoulder; Wd: 0.80 cm; H₁: 4.40 + x cm; throwing lines inside; smoothed on the wheel.**No. 29: amphora**, IV.TG 51 (= TD IV.19), body sherds.**No. 30: amphora**, Inv. No. C-1160 [002]Uncoated | IV.TG 52 (= TD IV.19 c.) | Ha₂

Handle fragment; attached vertical loop handle; Hd: 2.60 x 1.80 cm; smoothed.

Cypriote household ware**No. 31: amphora**, VI.TG 44, body sherds: 0.10 dm².**No. 32: amphora handle**, VI.TG 44, Hd: 2.90 x 2.20 cm.**No. 33: amphora**, VI.TG 49, body sherds: 0.10 dm².**I.- Finds****Suspended weights****No. 34: loom weight?**, Inv. No. F0240A (Drawing No. 0501). Fragmentary; limestone. 5.2

x 3.0 x 1.6 cm; no suspension grooves.

No. 35: net weight? (Fig. 48:2), Inv. No. F0241A (Drawing No. 0501). Fragmentary; limestone. 4.81 x 2.21 cm. Rounded shape; partially broken. Function: fishing. *Find No. 001.*

No. 36: loom weight (Plate 3), Inv. No. F0242. Complete; limestone. 4.00 x 8.30 cm. Oblong shape. Round depression carved on one of the faces. SCA No.1037. *Find No. 002.*

L1060 (Fig. 49)

I.- Pottery

a) Egyptian pottery

Nile silt clay

Household ware

No. 1: bowl (Fig. 49:1), Inv. No. C-1183 [001]

Uncoated	Nile B ₂	W ₂
----------	---------------------	----------------

Rim sherd everted direct rim. Rd: 23.00 cm 7/32; Wd: 0.70 cm; H₁: 2.60 + x cm; smoothed on the wheel; smoked.

No. 2: bowl (Fig. 49:1), Inv. No. C-1183 [002]

Uncoated	Nile B ₂	W ₂
----------	---------------------	----------------

Rim sherd; slightly carinated walls; everted direct rim. Rd: 20.00 cm 3/32; Wd: 0.80 cm; H₁: 4.20 + x cm; smoothed on the wheel.

No. 3: jar (Fig. 49:1), Inv. No. C-1183 [004]

Uncoated	Nile B ₂	W ₂
----------	---------------------	----------------

Rim sherd; vertical direct rim. Rd: 9.00 cm 5/32; Wd: 0.60 cm; H₁: 3.90 + x cm. Throwing lines inside; smoothed on the wheel.

No. 4: jar, Inv. No. C-1183 [011]

Uncoated	Nile B ₂	Ha ₂
----------	---------------------	-----------------

Handle fragment; vertical loop handle; Hd: 3.90 x 3.00 cm; smoothed; eroded. Others, Hd: 3.00 x 1.70 cm; Hd: 3.20 x 2.00 cm.

No. 5: jar, Inv. No. C-1183 [008]

Uncoated	Nile B ₂	W ₂	base finished on the wheel
----------	---------------------	----------------	----------------------------

Base fragment; pointed base; Wd: 0.70 cm; H₁: 2.70 + x cm. Throwing lines inside and outside; smoothed on the wheel.

No. 6: storage jar (Fig. 49:1), Inv. No. C-1183 [005]

Uncoated	Nile B ₂	W ₂
----------	---------------------	----------------

Rim sherd; inverted articulated exterior rim, modelled lip. Rd: 26.00 cm 1/16; Wd: 1.00 cm; H₁: 4.50 + x cm. Throwing lines inside; smoothed on the wheel; eroded inside.

No. 7: storage jar (Fig. 49:1), Inv. No. C-1183 [006]

Uncoated	Nile B ₂	W ₂
----------	---------------------	----------------

Rim sherd; inverted articulated interior and exterior rim, modelled lip. Rd: 26.00 cm 3/32; Wd: 1.00 cm; H₁: 4.50 + x cm. Throwing lines inside; smoothed on the wheel. Another, Nile C₁, Rd: 31.00 cm 1/16.

Pottery with special functions

No. 8: bakery tray (Fig. 49:1), Inv. No. P1080A (Drawing No. 0391)

Uncoated	Nile C ₂	W ₁	Ha	ox.	2
----------	---------------------	----------------	----	-----	---

Complete, fragmentary; articulated exterior rim. Rd: 20.00 cm 1/8; Bd: 18.00 cm 5/32; Wd: 1.70 cm; H₁: 4.00 cm. VI: 500. Surface colour: 5YR 5/4 reddish brown. Break: 10R 5/8 red. Surface treatment: uneven.

No. 9: bakery tray (Fig. 49:1), Inv. No. P1087A (Drawing No. 0389)

Uncoated	Nile C ₂	W ₁	Ha	ox.	2
----------	---------------------	----------------	----	-----	---

Complete, fragmentary; everted direct rim. Rd: 28.00 cm 3/32; Bd: 26.00 cm 3/32; Wd: 1.65 cm; H₁: 5.00 cm. VI: 560. Surface colour: 2.5YR 6/2 pale red. Break: 10R 4/3 weak red core; 10R 5/6 red oxidation zones. Technical details: pinched base; throwing lines inside the rim. Surface treatment: uneven. Others (rim only), Rd: 20.00 cm 1/16, Rd: 22.00 cm 1/32.

No. 10: tray, Inv. No. C-1183, Nile C₂, fragment; Wd: 4.00 cm.

Body sherds, Nile B₂, Nile C₁, Nile C₂, Marl F, Marl F v.s.

b) North Sinai/South Palestine pottery

Household ware

No. 11: amphora, Inv. No. C-1183, II.TG 09, body sherds.

c) Imported pottery

Levantine pottery

Fine ware

Bichrome ware

No. 12: jar (Fig. 49:1), Inv. No. P0780A (Drawing No. 0664)

WPBI	IV.TG 53 (= TD IV.08)	W ₂	---	me.	3
------	-----------------------	----------------	-----	-----	---

Body sherd. Md: 22.00 cm; Wd: 0.50 cm; H₁: 2.70 + x cm. Surface colour: 2.5Y 8/3 pale yellow slip. Break: 10R 4/1 dark reddish grey core; 10R 4/2 weak red oxidation zones. Technical details: throwing lines inside. Decoration: a painted band, 15 mm wide, and two lines, 2 mm wide, 10R 4/2 weak red. Surface treatment: polished, medium lustre.

Household ware

No. 13: jar (Fig. 49:2), Inv. No. P1280A (Drawing No. 0714)

Uncoated	IV.TG 06	W ₂	W	med.	3
----------	----------	----------------	---	------	---

Base fragment; ring base (R₃). Bd: 7.00 cm 7/32; Wd: 0.50 cm; H₁: 1.30 + x cm. Surface colour: 7.5YR 6/4 light brown. Break: 5Y 3/1 very dark grey core; 7.5YR 5/2 brown oxidation zones. Surface treatment: smoothed on the wheel.

No. 14: amphora (Fig. 49:2), Inv. No. P2036A (Drawing No. 0661)

Uncoated	IV.TG 11	W ₂	---	me.	3
----------	----------	----------------	-----	-----	---

Rim sherd, everted direct rim. Rd: 12.00 cm 3/64; Wd: 0.75 cm; H₁: 2.50 + x cm. Surface colour: 5Y 8/3 pale yellow. Break: 7.5YR 4/1 dark grey core; 5YR 7/8 reddish yellow and 5Y 8/3 pale yellow oxidation zones. Technical details: throwing lines inside. Surface treatment: smoothed on the wheel.

No. 15: amphora, Inv. No. C-1183, IV.TG 18, body sherds.

No. 16: amphora, IV.TG 31, body sherds.

Cypriote fine ware

White Painted ware

No. 17: jar (Fig. 49:2), Inv. No. P0781A (Drawing No. 0950)

BPMO	VI.TG 42	W ₂	---	ox.	3
------	----------	----------------	-----	-----	---

Body sherd. Md: 16.00 cm 3/32; Wd: 0.30 cm; H₁: 3.27 + x cm. Surface colour: 10YR 8/3 very pale brown slip. Break: 10YR 6/2 light brownish grey. Decoration: painted lines, 1-7 mm wide, 10YR 5/3 brown. Surface treatment: polished, low lustre.

White Painted IV

No. 18: jar or amphora? (Fig. 49:2), Inv. No. P0700A

WPMO	VI.TG 04	W ₂	---	ox.	3
------	----------	----------------	-----	-----	---

Wall fragment. Md: 22.00 + x cm; Wd: 0.80 cm; H₁: 6.10 + x cm. Surface colour: 2.5Y 7/3 pale yellow slip. Break: 2.5Y 6/6 olive yellow. Decoration: a horizontally painted band, 1 cm, and 5 lines 0.40 mm wide, 2.5Y 3/3 dark olive brown. Surface treatment: polished, medium lustre.

Cypriote household ware

No. 19: amphora, Inv. No. C-1183, VI.TG 40, body sherds.

No. 20: amphora (Fig. 49:2), Inv. No. P1277A (Drawing No. 0620)

Uncoated	VI.TG 49	Ha ₂	---	me.	2
----------	----------	-----------------	-----	-----	---

Handle fragment. Hd: 3.60 x 2.30 cm. Surface colour: 7.5YR 8/4 pink. Break: 7.5YR 6/4 light brown core; 7.5YR 7/4 pink oxidation zones. Surface treatment: smoothed.

II.- Finds

Suspended weight

No. 21: net weight (Fig. 49:2), Inv. No. F0183A (Drawing No. 0468). Complete; limestone. 6.80 x 4.10 x 2.90 cm; colour: 10YR 8/4 (very pale brown) and 10YR 4/4 (dark yellowish brown); oblong shape; two stringing grooves. *Find No. 004.*

Tool

No. 22: grinding stone, Inv. No. F0537A (Drawing No. 0332). Sandstone; very fragmentary.

L1061 (Fig. 50)

I.-Pottery

a) Egyptian pottery

Nile silt clay

Household ware

No. 1: jar (Fig. 50), Inv. No. C-1217 (2) [003]

Uncoated	Nile B ₂	W ₂
----------	---------------------	----------------

Rim sherd; inverted direct rim, round lip. Rd: 10.00 cm 3/32; Wd: 0.62 cm; H₁: 3.47 + x cm; throwing lines inside; smoothed on the wheel; smoked. Another, Rd: 10.00 cm 3/16.

No. 2: jar (Fig. 50), Inv. No. C-1217 (2) [001]

Uncoated	Nile B ₂	W ₂
----------	---------------------	----------------

Rim sherd; vertical direct rim, round lip. Rd: 10.00 cm 1/2; Wd: 0.66 cm; H₁: 4.40 + x cm; throwing lines inside; smoothed on the wheel. Another, Rd: 8.00 cm 5/32.

No. 3: jar (Fig. 50), Inv. No. C-1217 (2) [002]

Uncoated	Nile B ₂	W ₂
----------	---------------------	----------------

Rim sherd; everted direct rim, round lip. Rd: 10.00 cm 1/2; Wd: 0.56 cm; H₁: 4.47 + x cm;

throwing lines inside; smoothed on the wheel; smoked.

No. 4: jar, Inv. No. C-1217 (2) [017], handle fragment, Nile B₂. Hd: 3.40 x 2.20 cm; eroded. Others, Hd: 3.23 x 2.22 cm; Hd: 2.96 x 2.45 cm.

No. 5: storage jar (Fig. 50), Inv. No. C-1217 (2) [007]

Uncoated	Nile C ₁	W ₂
----------	---------------------	----------------

Rim and body sherd; inverted direct rim, trimmed lip. Rd: 22.00 cm 5/32 + 3/32; Wd: 1.00 cm; H₁: 5.56 + x cm; throwing lines inside; smoothed on the wheel.

Pottery with special functions

No. 6: lid (Fig. 50), Inv. No. C-1217 (2) [006]

Uncoated	Nile B ₂	W ₂
----------	---------------------	----------------

Rim sherd; everted direct rim, round lip. Rd: 23.00 cm 1/8; Wd: 0.60 cm; H₁: 3.19 + x cm; throwing lines inside; smoothed on the wheel; smoked. Another fragment, eroded.

No. 7: bakery tray, Inv. No. C-1217 (2) [[012]]

Uncoated	Nile C ₂	W ₁	Ha
----------	---------------------	----------------	----

Rim and base fragment; very small.

Egyptian marls

Household ware

No. 8: jar, Inv. No. C-1217 (2) [010]

Uncoated	Marl F	Ha ₂ + W ₂
----------	--------	----------------------------------

Handle and wall fragment; attached vertical loop handle; Hd: 2.96 x 1.86 cm; smoothed. Another, Hd: 2.66 x 1.78 cm.

Body sherds, Nile B₂, Nile C₂, Marl A₄, Marl F, Marl F v.s. Marl F + ochre.

b) North Sinai/South Palestine pottery

Household ware

No. 9: amphora, Inv. No. C-1217 (2), II.TG 09, body sherds.

c) Imported pottery

Levantine household ware

No. 10: amphora, Inv. No. C-1217 (2), IV.TG 01, handle and wall fragment; Wd: 1.10 cm; Hd: 3.22 x 2.20 cm.

No. 11: amphora, Inv. No. C-1217 (2), similar to IV.TG 23, body sherds.

No. 12: amphora, Inv. No. C-1217 (2), IV.TG 36, body sherds.

Aegean fine ware

Black-on-Red II

No. 13: juglet (Fig. 50), Inv. No. P0698A (Drawing No. 0388)

BPMO	VII.TG 45	W ₂	---	ox.	3
------	-----------	----------------	-----	-----	---

Body sherd. Md: 4.00 cm; Wd: 0.30 cm; H₁: 1.70 + x cm. Surface colour: 2.5YR 4/3 reddish brown slip. Break: 2.5YR 5/6 red. Decoration: horizontally painted lines, 1 mm wide, 2.5YR 2.5/2 very dusky red. Surface treatment: polished, high lustre.

Black-on-Red III ware

No. 14: juglet (Fig. 50), Inv. No. P0696A (Drawing No. 0310)

BPMO	VII.TG 45	W ₂	---	ox.	3
------	-----------	----------------	-----	-----	---

Body sherd. Md: 8.00 cm; Wd: 0.30 cm; H₁: 2.50 + x cm. Surface colour: 5YR 5/5 reddish

brown slip. Break: 5YR 6/6 reddish yellow. Technical details: throwing lines inside. Decoration: a painted swastika, 5YR 1.5/1 black. Surface treatment: polished, high lustre.

Black-on-Red II or III ware?

No. 15: juglet, Inv. No. P0697A (Drawing No. 0929)

WPMO	VII.TG 45	W ₂	---	ox.	3
------	-----------	----------------	-----	-----	---

Body sherd. Wd: 0.30 cm; H₁: 2.40 + x cm. Surface colour: 5YR 6/6 redish yellow slip. Break: 2.5YR 6/6 light red. Decoration: painted circles, 1 mm wide, 5YR 3/1 very dark grey. Surface treatment: polished, high lustre.

II.- Finds

Personal object

No. 16: bead, Inv. No. F0247A (Drawing No. 0501). Fragmentary; faience; moulded. 0.50 x 0.15 cm; colour: Chart 1 for gley 8/1 (light greenish grey). Cylindrical shape; perforation: 1 mm; eroded.

Object of unknown use

No. 17: stone fragment, Inv. No. F0268A. Granite, probably from a statue. 2.40 x 7.20 x 1.40 cm; very dark grey.

Product

No. 18: faience slag, Inv. No. F0314A.

Operations 36 and 41

Since these two test pits are adjacent, they will be treated as one, measuring 4.80 m x 2.0 m. They were dug into Casemate L1023 ([Plan V](#)). Note that the spot was affected by the crossing of a tank during the last Sinaitic war ([Graphic VI](#)).

Level	Locus	Description	Interpretation, comments
I	L1094	Clean, friable sand. Some painted sherds, kept in separate bags for mending.	Virgin soil or foundation sand
	L1096	Ditch	
	L1095	Fill of ditch L1096. Very sandy clay. Scarce pottery. Fish remains	
	L1090	Hearth	A floor and its hearth. They form a sealed context preceding Building C.
	L1091	The bottom of this locus is a thin but compact layer of clay.	
	L1069	Thick layer of sand with many small charcoals.	A possible floor preparation for Building C
	L1085	Ditch	
	L1084	Fill of ditch L1085	
	L1086	Pit filled by L1058	
II	L1008	Building C	
III	L1058	Dark, but lighter than L1001 and with less fish remains. Pottery abundant in its upper part and diminishing below. Many big sherds, which are kept in separate bags for mending. A	Occupational level

Level	Locus	Description	Interpretation, comments
III	L1058	complete juglet. Many handles suggest big jars; an imported sherd. Several small finds from a pit filled by this sediment (foundation deposit?)	
	L1065	Clots of clay and broken mud bricks in a sandy matrix. Few sherds. Remains of catfish	Building C was decaying
	L1070	Small narrow ditch	
	L1087	Charcoal and ashes	Hearth
	L1001	Pulverized pottery, fish bones, much charcoal	Destruction layer
	Topsoil	Thin grey dusty sand	

Archaeological material

L1001

See the archaeological material from this locus in p.319 and Fig. 58:1 to 58:17

L1008

As L1008 is also located from the excavation made in the Operation 25, all the archaeological material was included there.

L1058 (Fig. 51)

I.- Pottery

a) Egyptian pottery

Nile silt clay

Fine ware

Egyptian painted ware

Black on Red slip ware

No. 1: juglet (Fig. 51:1), Inv. No. P0001 (Drawing No. 0271)

RPMO	Nile E ₂	W ₁	W	ox.	2-3
------	---------------------	----------------	---	-----	-----

Nearly complete; no rim preserved; globular shape, raised base. Nd: 3.50 cm; Md: 10.00 cm; Bd: 3.90 cm; Wd: 0.45 cm; H₁: 15.00 + x cm; H₂: 5.80-6.00 cm; H₃: 5.00 + x cm; Hd: 1.35 x 1.80 cm. Surface colour: 10R 5/6 red slip. Break: 5YR 5/4 reddish brown. Technical details: throwing lines visible on the exterior surface; handle made from the body and fixed on the neck below the rim; deformed. Decoration: a horizontally painted band on the neck below the rim, and three bands at the major diameter, 10R 4/1 dark reddish grey. A groove on the neck above the handle. Surface treatment: polished. SCA.Find No. 011.

No. 2: juglet (Fig. 51:1), Inv. No. P7066A (Drawing No. 0929)

RP[MO]	Nile B ₂	W ₂	---	re.	2-3
--------	---------------------	----------------	-----	-----	-----

Body sherd. Md: 8.00 + x cm; Wd: 0.20 cm; H₁: 1.50 + x cm. Surface colour: 10R 5/6 red slip. Break: 2.5YR 4/6 red exterior; 4/1 dark reddish grey interior. Technical details: throwing lines inside. Decoration: ---. Surface treatment: polished, medium lustre.

Household ware**No. 3: bowl (Fig. 51:1), Inv. No. C-1214 (2bis) [006]**Uncoated Nile B₂ W₂

Rim sherd; inverted direct rim, round lip. Rd: 16.00 cm 1/16; Wd: 0.80 cm; H₁: 2.80 + x cm; smoothed on the wheel. Others, Rd: 17.00 cm 1/16, Rd: 18.00 cm 3/32, Rd: 24.00 cm 1/16.

No. 4: bowl, Inv. No. C-1112 [003]Uncoated Nile B₂ W₂

Rim sherd; inverted direct rim, flat lip. Rd: 20.00 cm 3/32; Wd: 0.70 cm; H₁: 2.70 + x cm; smoothed on the wheel; eroded.

No. 5: bowl (Fig. 51:1), Inv. No. C-1112 [016]Uncoated Nile B₂ W₂

Rim sherd; everted direct rim. Rd: 32.00 cm 1/16; Wd: 0.90 cm; H₁: 5.00 + x cm; smoothed on the wheel; smoked. Others, Rd: 19.00 cm 1/32, Rd: 28.00 cm 1/32. Nile C₁, Rd: 42.00 cm 1/16, Rd: 44.00 cm 1/32.

No. 6: bowl (Fig. 51:1), Inv. No. C-1112 [019]Uncoated Nile B₂ W₂

Rim sherd; everted direct rim, trimmed lip. Rd: 22.00 cm 1/16; Wd: 1.00 cm; H₁: 2.50 + x cm; smoothed on the wheel; eroded inside and outside.

No. 7: bowl, Inv. No. C-1112 (4) [005]Uncoated Nile B₂ W₂

Rim sherd; everted articulated exterior, trimmed lip. Rd: 44.00 cm 3/32; Wd: 1.00 cm; H₁: 6.20 + x cm; smoothed on the wheel; eroded.

No. 8: bowl (Fig. 51:1), Inv. No. C-1112 [008]Uncoated Nile B₂ W₂

Rim sherd; incurved walls; everted rim, bevelled lip. Rd: 30.00 cm 1/32; Wd: 0.90 cm; H₁: 3.50 + x cm. Throwing lines inside; smoothed on the wheel; eroded.

No. 9: bowl (Fig. 51:1), Inv. No. C-1112 [006]Uncoated Nile B₂ W₂

Rim sherd; incurved walls; everted articulated exterior rim, bevelled lip. Rd: 31.00 cm 1/16; Wd: 0.80 cm; H₁: 3.50 + x cm; smoothed on the wheel; eroded.

No. 10: bowl, Inv. No. C-1112 (3) [001]Uncoated Nile B₂ W₂ W

Base fragment; round base. Wd: 0.60 cm; H₁: 2.90 + x cm; smoothed on the wheel; eroded.

No. 11: carinated bowl, Inv. No. C-1214 (2) [002]Uncoated Nile B₂ W₂

Rim sherd; carinated bowl, inverted direct rim, trimmed lip. Rd: 26.00 cm 1/16; Wd: 0.65 cm; H₁: 3.60 + x cm; smoothed on the wheel.

No. 12: deep bowl (Fig. 51:2), Inv. No. C-1107 [002]Uncoated Nile E₁ W₂

Rim sherd; everted direct rim. Rd: 13.00 cm 1/16; Wd: 0.30 cm; H₁: 2.10 + x cm. Throwing lines outside; smoothed on the wheel; eroded.

No. 13: cup, Inv. No. C-1112Uncoated Nile B₂/C₁ W₂

Body fragment; incurved wall. Md: 7.00 cm; Wd: 0.60 cm. Throwing lines outside; smoothed on the wheel.

No. 14: juglet or model jar? (Fig. 51:2), Inv. No. C-1112 [024]Uncoated Nile B₂ W₂

Rim sherd; vertical direct rim. Rd: 5.00 cm 1/8; Nd: 1.70 cm; Wd: 0.30 cm; H₁: 2.30 + x cm. Throwing lines inside; smoothed on the wheel; eroded.

No. 15: juglet or model jar? (Fig. 51:2), Inv. No. C-1112 [029]Uncoated Nile B₂ W₂

Shoulder and body fragment. Md: 6.00 cm; Wd: 0.20 cm; H₁: 3.00 + x cm; smoothed on the wheel.

No. 16: juglet, Inv. No. C-1112 [009]Uncoated Nile E₂ W₂

Body fragment; incurved walls. Md: 6.00-7.00 cm; Wd: 0.50 cm; H₁: 2.80 + x cm; throwing lines inside; smoothed on the wheel.

No. 17: [globular] jar (Fig. 51:2), Inv. No. C-1112 [021]Uncoated Nile B₂ W₂

Rim sherd; vertical direct rim. Rd: 9.50 cm + 1/4; Nd: 2.90 cm; Wd: 0.60 cm; H₁: 3.50 + x cm. Throwing lines inside; smoothed on the wheel. Others, Rd: 9.50 cm 1/4, Rd: 10.00 cm 3/32, Rd: 11.00 cm 1/32. Nile C₁, Rd: 11.00 cm 3/32.

No. 18: jar (Fig. 51:2), Inv. No. C-1112 [015]Uncoated Nile B₂/C₁ W₂

Rim sherd; inverted articulated interior and exterior rim. Rd: 14.00 cm 1/8; Wd: 0.60 cm; H₁: 5.70 + x cm. Throwing lines inside; smoothed on the wheel; smoked outside.

No. 19: jar (Fig. 51:2), Inv. No. C-1112 [012]Uncoated Nile B₂/C₁ W₂

Rim sherd; inverted articulated exterior rim, trimmed lip. Rd: 17.00 cm 5/32; Wd: 1.00 cm; H₁: 7.00 + x cm. Throwing lines inside; smoothed on the wheel; eroded inside.

No. 20: jar (Fig. 51:2), Inv. No. C-1112 [004]Uncoated Nile B₂ W₂

Rim sherd; inverted direct rim. Rd: 11.00 cm 5/32; Wd: 0.60 cm; H₁: 3.00 + x cm. Throwing lines inside; smoothed on the wheel; smoked. Others, Rd: 10.00 cm 1/4, Rd: 10.00 cm 1/8, Rd: 10.00 cm 1/8, Rd: 12.00 cm 1/4.

No. 21: jar, Inv. No. C-1112 (4) [002]Uncoated Nile B₂ W₂

Rim sherd; inverted direct rim, modelled lip. Rd: 10.00 cm 1/8; Wd: 0.60 cm; H₁: 4.20 + x cm; throwing lines inside; smoothed on the wheel; eroded.

No. 22: jar (Fig. 51:2), Inv. No. C-1112 (5) [002]Uncoated Nile B₂ W₂

Rim sherd; vertical direct rim, round lip. Rd: 12.00 cm 3/32; Wd: 0.70 cm; H₁: 4.00 + x cm; throwing lines inside; smoothed on the wheel; eroded. Others, Rd: 8.00 cm 3/8, Rd:

10.00 cm $\frac{1}{8}$, Rd: 14.00 cm $\frac{5}{32}$, Rd: 16.00 cm $\frac{5}{32}$, Rd: 18.00 cm $\frac{9}{32}$.

No. 23: jar (Fig. 51:2), Inv. No. C-1107 [001]

Uncoated | Nile B₂ | W₂

Rim sherd; vertical articulated interior rim. Rd: 13.00 cm $\frac{1}{8}$; Wd: 0.70 cm; H₁: 4.50 + x cm. Throwing lines inside and outside; smoothed on the wheel; eroded.

No. 24: jar (Fig. 51:2), Inv. No. C-1107 (2) [001]

Uncoated | Nile B₂ | W₂

Rim sherd; everted direct rim. Rd: 7.00 cm $\frac{3}{16}$; Nd: 4.70 cm; Wd: 0.65 cm; H₁: 3.10 + x cm. Throwing lines inside; smoothed on the wheel; eroded. Others, Rd: 10.00 cm $\frac{1}{4}$, Rd: 10.60 cm $\frac{3}{16} + \frac{1}{8}$, Rd: 12.00 cm $\frac{3}{32}$.

No. 25: jar (Fig. 51:2), Inv. No. C-1112 [018]

RS | Nile B₂ | W₂

Rim sherd; everted articulated simmetrical rim. Rd: 16.00 cm $\frac{1}{8}$; Wd: 1.10 cm; H₁: 7.80 + x cm. Throwing lines inside; red slipped surface; smoothed on the wheel; eroded.

No. 26: jar, Inv. No. C-1112 [028]

Uncoated | Nile B₂ | W₂

Body fragment; Md: 14.00 cm; Wd: 0.60-1.20 cm; H₁: 8.50 + x cm. Throwing lines inside; smoothed on the wheel; smoked outside.

No. 27: jar, Inv. No. C-1107

Uncoated | Nile B₂ | W₂

Neck fragment. Nd: 8.00 cm $\frac{1}{4}$; Wd: 0.50 cm. Throwing lines inside and outside; smoothed on the wheel.

No. 28: jar, Inv. No. C-1112 (4)

Uncoated | Nile B₂ | W₂ | W

Base fragments; round base; Wd: 1.00 cm. Another, Wd: 0.90 cm.

No. 29: jar, Inv. No. C-1112 (2)

Uncoated | Nile B₂ | W₂ | base finished on the wheel

Base fragment; pointed base; eroded.

No. 30: jar, Inv. No. C-1112 [017]

Uncoated | Nile B₂/C₁ | W₂ | base finished on the wheel

Base fragment; ring base (R₃). Bd: 6.00 cm $\frac{1}{8}$; Wd: 0.80 cm; H₁: 2.50 + x cm. Throwing lines inside; smoothed on the wheel; eroded. Another, Bd: 8.00 cm $\frac{1}{4}$.

No. 31: storage jar, Inv. No. C-1107 [005]

Uncoated | Nile B₂ | W₂

Rim and body fragment; inverted articulated exterior, flat lip. Rd: 22.00 cm $\frac{5}{32}$; Wd: 1.00 cm; H₁: 11.00 + x cm; throwing lines inside; smoothed on the wheel; eroded.

No. 32: storage jar, Inv. No. C-1112 [006]

Uncoated | Nile B₂ | W₂

Rim sherd; inverted direct rim; modelled lip. Rd: 26.00 cm $\frac{1}{8}$; Wd: 1.00 cm; H₁: 7.20 + x cm; throwing lines inside; smoothed on the wheel; eroded.

No. 33: storage jar (Fig. 51:2), Inv. No. C-1112 [007]Uncoated Nile B₂/C₁ W₂

Rim sherd; inverted articulated interior and exterior rim, rolled lip. Rd: 22.00 cm 3/32; Wd: 1.00 cm; H₁: 5.50 + x cm. Throwing lines inside; smoothed on the wheel; eroded inside. Another, Nile B₂, Rd: 20.00 cm 3/32.

No. 34: storage jar, Inv. No. C-1214 (2bis) [005]Uncoated Nile B₂ W₂

Rim sherd; inverted articulated interior and exterior, round lip. Rd: 22.00 cm 1/8; Wd: 0.80 cm; H₁: 6.10 + x cm; throwing lines inside; smoothed on the wheel; eroded.

No. 35: storage jar, Inv. No. C-1112 (5) [004]Uncoated Nile B₂ W₂

Rim sherd; inverted direct rim, round lip. Rd: 28.00 cm 3/32; Wd: 1.40 cm; H₁: 6.50 + x cm; throwing lines inside; eroded. Another, Rd: 20.00 cm 1/16.

No. 36: storage jar, Inv. No. C-1112 (4) [006]Uncoated Nile B₂ W₂

Body fragment; incurved wall; Md: ca. 30.00 cm; Wd: 0.90 cm.

No. 37: amphora, Inv. No. C-1112 (5) [006]Uncoated Nile B₂ Ha₂ + W₂

Handle and body fragment; "torpedo" type; attached vertical loop handle, upper body-shoulder. Md: 28.00 cm on the shoulder; Wd: 0.60 cm; H₁: 3.40 + x cm; Hd: 3.30 x 1.70 cm; eroded and smoked.

Pottery with special functions**No. 38: bakery tray (Fig. 51:3), Inv. No. P1029A (Drawing No. 0378)**Uncoated Nile B₂ W₁ Ha med. 2

Complete, fragmentary; articulated exterior rim. Rd: 26.00 cm 3/32; Bd: 24.00 cm 3/32; H₁: 5.00 cm. VI: 520. Surface colour: 5YR 6/3 light reddish brown. Break: core: 2.5YR 5/4 reddish brown. Surface treatment: smoothed.

No. 39: bakery tray (Fig. 51:3), Inv. No. P1027A (Drawing No. 0378)Uncoated Nile B₂ W₁ Ha ox. 2

Complete, fragmentary; articulated exterior rim. Rd: 12.00 cm 1/4; Bd: 10.00 cm 1/4; Wd: 1.15-1.60 cm; H₁: 3.30 cm. VI: 364. Surface colour: 10R 6/4 pale red. Break: 10R 5/4 weak red. Surface treatment: uneven.

No. 40: bakery tray (Fig. 51:3), Inv. No. P1079A (Drawing No. 0391)Uncoated Nile B₂ W₁ Ha me. 2

Complete, fragmentary; articulated exterior rim. Rd: 18.00 cm 5/32; Bd: 14.40 cm 7/32; Wd: 1.30 cm 7/32; H₁: 3.80 cm. VI: 474. Surface colour: 7.5YR 5/4 brown. Break: 7.5YR 3/1 very dark grey core; 10R 5/6 red oxidation ones. Surface treatment: uneven.

No. 41: bakery tray (Fig. 51:3), Inv. No. P1028A (Drawing No. 0385)Uncoated Nile C₂ W₁ H ox. 2

Complete, fragmentary; everted direct rim. Rd: 20.00 cm 5/32; Bd: 18.00 cm 1/8; Wd: 1.80 cm; H₁: 5.40 cm. VI: 370. Surface colour: ---. Break: ---. Surface treatment: ---. Deformed; eroded and smoked. Others, Nile C₁, Rd: 22.00 cm 3/16; Bd: 20.50 cm; Wd: 1.80 cm; H₁: 4.30 cm. VI: 512; rim, Nile B₂, Rd: 17.00 cm 3/32.

No. 42: tray, Inv. No. C-1112 (4), Nile C₂, body sherd.

Egyptian marls

Household ware

No. 43: jar (Fig. 51:3), Inv. No. C-9067 [001]

Uncoated	Marl F + ochre	W ₂
----------	----------------	----------------

Rim sherd; vertical direct rim. Rd: 7.00 cm 1/16; Wd: 0.35 cm; H₁: 2.30 cm. Throwing lines inside; smoothed on the wheel.

No. 44: jar (Fig. 51:3), Inv. No. C-1112 (5) [009]

Uncoated	Marl A ₄	W ₂
----------	---------------------	----------------

Neck and body sherd; flaring inside wall. Nd: 8.00 cm 1/8; Wd: 0.35 cm; H₁: 3.90 + x cm; throwing lines inside; smoothed on the wheel; smoked.

No. 45: jar (Fig. 51:4), Inv. No. P0742A (Drawing No. 0308)

Uncoated	Marl A ₄	W ₂	---	ox.	3
----------	---------------------	----------------	-----	-----	---

Incomplete, fragmentary; no base preserved; piriform shape; vertical articulated exterior rim, rounded lip. Rd: 7.30 cm 3/4; Nd: 7.00 cm; Wd: 0.35 cm; H₁: 11.00 + x cm; H₃: 2.20 cm. Surface colour: 2.5YR 7/3 pale yellow. Break: 2.5YR 7/3 pale yellow. Technical details: throwing lines inside. Surface treatment: smoothed on the wheel.

No. 46: jar (Fig. 51:4), Inv. No. P0743A (Drawing No. 0308)

Uncoated	Marl A ₄	W ₂	W	ox.	3
----------	---------------------	----------------	---	-----	---

Base and body fragment; flat base. Bd: 4.40 cm; Wd: 0.45 cm; H₁: 2.40 + x cm. Surface colour: 10YR 6/6 brownish yellow. Break: 10YR 6/6 brownish yellow exterior; 2.5YR 6/6 light red interior. Technical details: throwing lines inside. Surface treatment: smoothed on the wheel. *Find No. 003*.

No. 47: jar (Fig. 51:4), Inv. No. C-1112 (7) [001]

Uncoated	Marl A ₄	W ₂
----------	---------------------	----------------

Rim sherd; inverted modelled rim. Rd: 10.00 cm 7/32; Wd: 0.80 cm; H₁: 3.70 + x cm; throwing lines inside; smoothed on the wheel; eroded.

No. 48: jar, Inv. No. C-9067 [002]

Uncoated	Marl A ₄	W ₂
----------	---------------------	----------------

Wall fragment; convex sided. Md: 14.00 cm; Wd: 0.50 cm; H₁: 2.30 cm. Throwing lines inside; smoothed on the wheel.

No. 49: jar, Inv. No. C-1107 [001]

Uncoated	Marl F	W ₂
----------	--------	----------------

Rim sherd; inverted articulated exterior, round lip. Rd: 10.00 cm 1/8; Wd: 0.65 cm; H₁: 4.90 + x cm; throwing lines inside; smoothed on the wheel; eroded.

No. 50: jar, Inv. No. C-1214 (2bis) [003]

Uncoated	Marl F	W ₂
----------	--------	----------------

Rim sherd; everted direct rim, round lip. Rd: 10.00 cm 5/32; Wd: 0.60 cm; H₁: 3.00 + x cm; throwing lines inside; smoothed on the wheel.

No. 51: amphora (Fig. 51:4), Inv. No. P1120A (Drawing No. 0642)

Uncoated	Marl A ₄	W ₂	---	ox.	3
----------	---------------------	----------------	-----	-----	---

Body fragment. Md: 30.00-31.00 cm; Wd: 0.30 cm; H₁: 17.00 + x cm. Surface colour: 2.5YR 6/6 light red inside, 2.5Y 7/2 light grey outside (self slip). Break: 2.5YR 6/6 light

red interior; 2.5YR 7/2 pale red exterior. Technical details: throwing line inside and outside. Surface treatment: smoothed on the wheel.

Body sherds, Nile B₂, Nile C₁, Nile E₂. Marl A₄, Marl F, Marl F v.s.

- Nile B₂, handle fragments, Hd: 3.00 x 1.70 cm; Hd: 3.20 x 2.80 cm; others 3 handle fragments; rim fragments, 30 rim sherds, very small and eroded.

- Marl F, 3 handle fragments.

b) North Sinai/South Palestine pottery

Household ware

No. 52: amphora, II.TG 08, body sherds.

No. 53: amphora, Inv. No. C-1112 [026]

Uncoated | II.TG 09 | Ha₂

Handle fragment; inserted vertical loop handle; Hd: 2.50 x 1.40 cm; eroded.

No. 54: amphora, II.TG 09, body sherds.

No. 55: amphora, II.TG 10, body sherds.

c) Imported pottery

Levantine household ware

No. 56: pilgrim flask? (Fig. 51:5), Inv. No. C-1112 (5) [008]

Uncoated | IV.TG 51 (=TD IV.19) | Ha₂

Neck, handle and wall fragment; vertical loop handles. Nd: 2.50 cm 1/1; Wd: 0.40-0.70 cm; H₁: 5.00 + x cm; Hd: 1.30 x 1.25 cm; smoothed.

No. 57: amphora, IV.TG 01, body sherds.

No. 58: amphora, IV.TG 06, body sherds.

No. 59: amphora, IV.TG 07, body sherds.

No. 60: amphora, Inv. No. C-1214 (2bis) [007]

Uncoated | IV.TG 11 | Ha₂ + W₂

Handle and wall fragment; attached vertical loop handle body to body. Wd: 0.60 cm; H₁: 6.70 + x cm; Hd: 2.50 x 1.20 cm; smoothed.

No. 61: amphora, IV.TG 11, body sherds.

No. 62: amphora, IV.TG 18, body sherds.

No. 63: amphora, IV.TG 23, body sherds.

No. 64: amphora, Inv. No. C-1112 [010]

Uncoated | IV.TG 24 | Ha₂

Handle fragment; Hd: 1.90 x 1.15 cm; smoothed.

No. 65: amphora, IV.TG 51 (=TD IV.19), body sherds.

No. 66: amphora, IV.TG 52 (=TD IV.19 c.), body sherds.

No. 67: amphora, similar to IV.TG 61, body sherds.

No. 68: amphora, = TD IV.02, body sherds.

No. 69: amphora, = TD IV.08, body sherds.

Cypriote household ware

No. 70: amphora, VI.TG 40, body sherds and fragment of a handle.

No. 71: amphora, VI.TG 43, body sherds.

Aegean fine ware

Black-on-Red ware

No. 72: juglet (Fig. 51:5), Inv. No. P1050A (Drawing No. 0929)

RPMO	VII.TG 45	W ₂	---	ox.	4
------	-----------	----------------	-----	-----	---

Body sherd. Md: 10.00 + x cm; Wd: 0.30 cm; H₁: 2.00 + x cm. Surface colour: 2.5YR 6/8 light red slip. Break: 2.5YR 6/8 light red. Decoration: ---. Surface treatment: polished; medium lustre.

Black-on-Red II ware?

No. 73: juglet (Fig. 51:5), Inv. No. P0704A (Drawing No. 0301)

RPMO	VII.TG 45	W ₂	---	ox.	3
------	-----------	----------------	-----	-----	---

Body sherd. Md: ca. 8.00 cm; Wd: 0.30 cm; H₁: 2.00 + x cm. Surface colour: 10R 5/6 red slip. Break: 10R 6/6 light red exterior; 7.5YR 6/4 light brown interior. Technical details: throwing lines inside. Decoration: horizontally painted lines, 7.5YR 3/1 very dark grey. Surface treatment: polished, high lustre. *Find No. 005.*

II.- Finds

Religion

No. 74 : baboon figurine (Plate 4), Inv. No. F0243. Fragmentary; faience; moulded. 2.90 x 6.20 x 2.50 cm; colour: blue. Seated baboon with the sun disc on the head; the upper part of the dish is broken. Function: amulet. SCA No. 1033. *Find No. 006.*

No. 75: double flute player-shaped pendant (Plate 5), Inv. No. F0254. Fragmentary; faience; moulded. 2.20 x 2.30 x 2.50 cm; colour: 2.5Y 8/2 pale yellow; a transversal perforation and a loop on the neck. SCA No.1039. *Find No. 014.*

No. 76: Bes object (Plate 6), Inv. No. F0258. Fragmentary; faience; moulded. 3.40 x 3.40 x 1.00 cm; colour: 2.5Y 8/3 (pale yellow). Four longitudinal holes. Double Bes. SCA No. 1042. *Find No. 012.*

Personal objects

No. 77: bead, Inv. No. F0253. Complete; eroded; quartz. D: 2.00 cm; spherical shape. SCA No. 1040. *Find No. 013.*

No. 78: bead (Fig. 51:5), Inv. No. F0256A (Drawing No. 0501). Fragmentary; faience; moulded. 0.70 (diameter) x 0.20 cm; colour: 2.5Y 8/1 (white). remains of green colour; perforation: 1.5 mm. *Find No. 015.*

No. 79: pendant?, Inv. No. F00259A. Fragmentary, eroded; faience; moulded. 1.20 x 0.80 x 0.50 cm; colour: 2.5Y 7/3 (pale yellow). Perforation: 2 mm in diameter; three incised lines, as decoration? *Find No. 019.*

No. 80: bead, Inv. No. F0262A (Drawing No. 0463). Complete; faience; moulded. 0.30 x 0.10 cm; colour: 10YR 7/1 (light grey). Cylindrical shape; rest of light blue colour; perforation: 1.5 mm. *Find No. 017.*

No. 81: bead, Inv. No. F0920A (Drawing No. 0913). Complete; bone (raye vertebra). 0.50 x 0.20 cm; a perforation, 1 mm wide. Used as a bead.

Objects of unknown use

No. 82: fragment of an object, Inv. No. F0238A. Bronze. 0.81 x 0.80 x 0.67 cm. *Find No. 005.*

No. 83: fragment of an object, Inv. No. F0252A. Bronze. 1.35 x 1.20 x 0.65 cm. *Find No. 009.*

No. 84: fragment of an object, Inv. No. F0263A. Bronze. 0.83 x 0.62 cm. *Find No. 018.*

No. 85: fragment of an object, Inv. No. F0741A. Bronze. 0.60 x 0.26 cm.

Products**No. 86: faience slag**, Inv. No. F0594A.**No. 87: faience slag**, Inv. No. F0778A.**No. 88: faience slag**, Inv. No. F0791A.**No. 89: faience slag**, Inv. No. F0798A.**No. 90: faience slag**, Inv. No. F0804A.**No. 91: faience slag**, Inv. No. F0806A.**Raw material****No. 92: stone**, Inv. No. F0427A (before F0236A). Chert?; 2.13 x 2.30 x 1.10 cm; colour: 5YR 2.5/1; oval shape. *Find No. 004.***L1065 (Fig. 52)****I.- Pottery****a) Egyptian pottery****Nile silt clay****Household ware****No. 1: deep bowl** (Fig. 52), Inv. No. C-1162 [001]Uncoated | Nile B₂ | W₂Rim sherd; incurved walls, inverted direct rim. Rd: 14.00 cm 1/16; Wd: 0.40 cm; H₁: 3.70 + x cm. Throwing lines outside; smoothed on the wheel; eroded.**No. 2: jar**, Inv. No. C-1156 (2) [002]Uncoated | Nile B₂ | W₂Neck and body fragment; globular shape. Nd: 10.00 cm; Wd: 0.90 cm; H₁: 7.00 + x cm; smoothed on the wheel; eroded.**No. 3: jar** (Fig. 52), Inv. No. C-1156 [001]Uncoated | Nile B₂ | W₂Rim sherd; everted direct rim. Rd: 12.00 cm 3/32; Wd: 0.70 cm; H₁: 3.50 + x cm. Throwing lines inside and outside; smoothed on the wheel; eroded.**No. 4: jar** (Fig. 52), Inv. No. C-1156 [002]Uncoated | Nile B₂ | W₂Rim sherd; everted articulated exterior rim. Rd: 10.00 cm 3/16; Wd: 0.50 cm; H₁: 2.85 + x cm. Throwing lines inside and outside; smoothed on the wheel; eroded.**No. 5: jar**, Inv. No. C-1162 [003]Uncoated | Nile B₂ | W₂ | base finished on the wheelBase fragment; pointed base. Wd: 0.80 cm; H₁: 5.00 + x cm. Throwing lines inside and outside; smoothed on the wheel; eroded.**Pottery with special functions****No. 6: "pigeon pot"** (Fig. 52), Inv. No. C-1162 [002]Uncoated | Nile B₂ | W₂ | WBase sherd. Bd: 4.00 cm 1/4; Wd: 1.50 cm; H₁: 5.00 + x cm. Throwing lines inside; made in parts; smoothed on the wheel; eroded.**Body sherds**, Nile B₂, Nile C₂, Marl A₄, Marl F, Marl F + ochre.

b) Imported pottery**Levantine household ware**

No. 7: amphora, Inv. No. C-1156, IV.TG 18, body sherds.

No. 8: amphora, Inv. No. C-1162, IV.TG 23, body sherds and handle fragment, Hd: 3.15 x 1.80 cm.

Cypriote household ware

No. 9: amphora, Inv. No. C-1156, VI.TG 49, body sherds.

L1069 (Fig. 53)**I.- Pottery****a) Egyptian pottery****Nile silt clay****Household ware**

No. 1: bowl, Inv. No. C-1148 (3) [005]

Uncoated	Nile B ₂	W ₂	Base finished on the wheel
----------	---------------------	----------------	----------------------------

Base fragment; ring base (R₃). Bd: 12.00 cm 1/8; Wd: 0.70 cm; H₁: 4.00 + x cm; throwing lines inside; smoothed on the wheel; eroded.

No. 2: juglet, Inv. No. C-1113 [008]

Uncoated	Nile B ₂	Ha ₂
----------	---------------------	-----------------

Handle fragment; loop handle; Hd: 1.15 x 0.65 cm; 1; single strap; smoothed.

No. 3: jar (Fig. 53), Inv. No. C-1148 (2) [002]

Uncoated	Nile B ₂	W ₂
----------	---------------------	----------------

Rim sherd; slightly inverted direct rim. Rd: 10.00 cm 3/16; Wd: 0.70 cm; H₁: 4.50 + x cm; throwing lines inside; smoothed on the wheel; eroded. Another, Rd: 10.00 cm 1/16.

No. 4: jar (Fig. 53), Inv. No. C-1113 [002]

Uncoated	Nile B ₂	W ₂
----------	---------------------	----------------

Rim sherd; vertical direct rim, round lip. Rd: 12.00 cm; Wd: 0.50 cm.; H₁: 4.10 + x cm; throwing lines inside; smoothed on the wheel; eroded.

No. 5: jar (Fig. 53), Inv. No. C-1100 [001]

Uncoated	Nile B ₂	W ₂
----------	---------------------	----------------

Rim sherd; everted simmetrical rim, flat lip. Rd: 16.00 cm 5/32; Wd: 0.60 cm; H₁: 4.00 + x cm; throwing lines inside; smoothed on the wheel.

No. 6: jar, Inv. No. C-1148 (2) [001]

Uncoated	Nile B ₂	W ₂	W
----------	---------------------	----------------	---

Base fragment; round base; Wd: 1.20 cm.; H₁: 4.90 + x cm; eroded, salt incrustated, smoked.

No. 7: jar, Inv. No. C-1148 (3) [006]

Uncoated	Nile B ₂	Ha ₂
----------	---------------------	-----------------

Handle fragment; vertical loop handle; Hd: 2.75 x 2.30 cm; 1; single strap; eroded and salt incrustated. Others, Hd: 2.90 x 1.85 cm; Hd: 3.20 x 2.30 cm.

No. 8: storage jar, Inv. No. C-1148 (3) [009]

Uncoated	Nile E ₂	W ₂
----------	---------------------	----------------

Body fragment. Md: 30.00-32.00 cm; Wd: 1.10-1.20 cm; H₁: 23.50 + x cm; throwing lines

inside; smoothed on the wheel; eroded.

No. 9: storage jar (Fig. 53), Inv. No. C-1113 [001]

Uncoated	Nile B ₂	W ₂
----------	---------------------	----------------

Rim and body fragment; inverted direct rim, flat lip. Rd: 20.00 cm. 1/8; Wd: 0.70 cm.; H₁: 8.80 + x cm.; throwing lines inside; smoothed in the wheel; eroded.

Pottery with special functions

No. 10: lid (Fig. 53), Inv. No. C-1148 (3) [002]

Uncoated	Nile B ₂ s.	W ₂
----------	------------------------	----------------

Rim sherd; everted direct rim. Rd: 27.00 cm 5/32; Wd: 0.70 cm; H₁: 3.90 + x cm; throwing lines inside; smoothed on the wheel; eroded and salt incrustated.

No. 11: bakery tray, Inv. No. C-1148 (3) [004]

Uncoated	Nile B ₂	W ₁
----------	---------------------	----------------

Rim sherd; everted direct rim; eroded.

Body sherds, Nile B₂, Nile C₂, Marl A₄, Marl F, Marl F + ochre.

b) North Sinai/South Palestine pottery

Household ware

No. 12: amphora, Inv. No. C-1148, II.TG 10, body sherd.

c) Imported pottery

Levantine household ware

No. 13: amphora, Inv. No. C-1148, IV.TG 11, body sherd.

No. 14: amphora, Inv. No. C-1148, IV.TG 29, handle fragment, Hd: 3.10 x 2.20 cm.

No. 15: amphora, Inv. No. C-1148, IV.TG 52 (= TD IV.19 c.), body sherd.

No. 16: amphora, Inv. No. C-1148, IV.TG 53, body sherd.

Cypriote household ware

No. 17: amphora, Inv. No. C-1148 (3) [003]

Uncoated	VI.TG 04	W ₂
----------	----------	----------------

Rim sherd; inverted direct rim. Rd: 12.00 cm 1/8; Wd: 0.90 cm; H₁: 3.70 + x cm; throwing lines inside; smoothed on the wheel; eroded and salt incrustated.

No. 18: amphora, Inv. No. C-1148, VI.TG 43, body sherd.

No. 19: amphora, Inv. No. C-1113, VI.TG 40, body sherds.

II.- Finds

Religion

No. 20: frog amulet, Inv. No. F0278A. Faience. 1.30 x 1.00 x 0.70 cm; colour: 10YR 8/2 (very pale brown). Broken. *Find No. 006*.

Tool

No. 21: grinding stone (Fig. 53), Inv. No. F0255A (Drawing No. 0352/1024). Complete; limestone. Weight: 275.00 grs. 8.30 x 7.80 x 3.40 cm; colour: pinkish grey and light reddish brown 5YR 7/2 - 6/3. Degree of wear: 3-Hard. Surfaces: 2; contact: 2; surface configuration: flat-concave; surface texture: sandy. Redisues: pigment? *Find No. 010*.

Product

No. 22: faience slag, Inv. No. F0779A.

L1084 (Fig. 54)**I.- Pottery****Egyptian pottery****Nile silt clay****Household ware**

No. 1: bowl (Fig. 54), Inv. No. C-1216 [001]

Uncoated	Nile C ₁	W ₂
----------	---------------------	----------------

Rim and wall fragment; everted direct rim, round lip. Rd: 26.00 cm 1/8; Wd: 0.80 cm; H₁: 6.00 + x cm; throwing lines inside; smoothed on the wheel; eroded. Another, rim eroded.

No. 2: bowl, Inv. No. C-1216 [006]

Uncoated	Nile B ₂	W ₂
----------	---------------------	----------------

Rim sherd. Rd: 20.00 cm? 3/32; eroded.

No. 3: juglet, Inv. No. C-1102 [001]

Uncoated	Nile B ₂	W ₂
----------	---------------------	----------------

Rim sherd; everted direct rim, round lip. Rd: 3.60 cm 1/1; Wd: 0.50 cm; H₁: 3.30 + x cm; throwing lines inside; smoothed on the wheel; eroded.

No. 4: jar, Inv. No. C-1102 [002]

Uncoated	Nile B ₂	W ₂
----------	---------------------	----------------

Rim sherd; vertical direct rim, round lip. Rd: 12.60 cm 5/32; Wd: 0.65 cm; H₁: 4.50 + x cm; throwing lines inside; smoothed on the wheel; eroded. Another, Rd: 10.00 cm 3/32.

No. 5: jar (Fig. 54), Inv. No. C-1216 [002]

Uncoated	Nile B ₂	W ₂
----------	---------------------	----------------

Rim sherd; everted direct rim, round lip. Rd: 14.00 cm 3/32; Wd: 0.60 cm; H₁: 4.50 + x cm; throwing lines inside; smoothed in the wheel; eroded. Another, Rd: 8.00 cm 1/4.

No. 6: jar, Inv. No. C-1216 [005]

Uncoated	Nile B ₂	W ₂
----------	---------------------	----------------

Base fragment; ring base; Bd: 8.00 cm 1/4; eroded.

No. 7: jar, Inv. No. C-1151 [002]

Uncoated	Nile B ₂	W ₂
----------	---------------------	----------------

Base fragment; round base; Wd: 0.65 cm; H₁: 3.50 + x cm; throwing lines inside and outside; smoothed outside.

No. 8: jar, Inv. No. C-1216 [004]

Uncoated	Nile B ₂	W ₂
----------	---------------------	----------------

Body sherd; Md: ca. 8.00 cm; Wd: 1.00 cm; H₁: 6.90 + x cm; throwing lines inside; smoothed on the wheel.

Pottery with special functions

No. 9: bakery tray (Fig. 54), Inv. No. C-9077 [001]

Uncoated	Nile C ₂	W ₁	Ha
----------	---------------------	----------------	----

Rim and base fragment; flat base everted direct rim. Rd: 24.00 cm 3/16; Bd: 22.00 cm; Wd: 2.00 cm; H₁: 5.05 cm. VI: 475. Throwing lines inside; smoothed on the wheel.

No. 10: "pigeon pot", Inv. No. C-1216 [007]

Uncoated	Nile B ₂	W ₂	W
----------	---------------------	----------------	---

Base sherd. Bd: 5.00 cm? 1/4, eroded.

Egyptian marls

Household ware

No. 11: amphora (Fig. 54), Inv. No. P1121A (Drawing No. 0637)

Uncoated	Marl A ₄	W ₂ + Ha ₂	---	ox.	3
----------	---------------------	----------------------------------	-----	-----	---

Body fragment and handle. Md: 24.00 + x cm; Wd: 0.30 cm; H₁: 11.50 + x cm; Hd: 1.70 x 1.00 cm. Surface colour: 2.5YR 6/4 inside, 10YR 7/6 light grey outside (self slip). Break: 2.5YR 6/4 light reddish brown core; 10YR 7/2 light grey oxidation zones. Technical details: throwing lines inside; ribbed surface; applied handle. Surface treatment: smoothed on the wheel.

Mixed clay

No. 12: amphora, Inv. No. C-1102 [004]

Uncoated	Mixed clay	Ha ₂
----------	------------	-----------------

Handle fragment; loop handle; Hd: 3.25 x 2.70 cm; 1; single strap; smoothed.

Body sherds, Nile B₂, Nile C₂, Marl A₄, Marl F.

b) Imported pottery

Levantine household ware

No. 13: amphora, IV.TG 01, body sherds.

No. 14: amphora, IV.TG 24, body sherds.

No. 15: amphora, IV.TG 51 (= TD IV.19), body sherds.

No. 16: amphora, IV.TG 52 (= TD IV.19 c.), body sherds.

Aegean fine ware

Black-on-Red ware?

No. 17: juglet (Fig. 54), Inv. No. P2039A (Drawing No. 0702)

RP[MO?]	VII.TG 39	W ₂	---	ox.	3
---------	-----------	----------------	-----	-----	---

Rim and neck fragment, direct rim. Rd: 3.10 cm; Nd: 1.20 cm; Wd: 0.20 cm; H₁: 1.80 + x cm. Surface colour: 2.5YR 7/6 light red slip. Break: 10R 6/8 light red. Decoration: two painted lines on the neck and a line along the rim, 2 mm wide, 7.5YR 3/1 very dark grey. Surface treatment: polished.

No. 18: juglet, Inv. No. P0379A (Drawing No. 0158)

BPMO	VII.TG 45	W ₂	---	ox.	3
------	-----------	----------------	-----	-----	---

Body fragment. Md: 15.00 + x cm; Wd: 0.35 cm; H₁: 2.40 + x cm. Surface colour: 7.5YR 6/4 light brown slip. Break: 7.5YR 6/4 light brown. Decoration: horizontally painted lines, 7.5YR 3/1 very dark grey. Surface treatment: polished, high lustre.

II.- Finds

Product

No. 19: slag, Inv. No. F0799A.

L1090 (Fig. 55)**I.- Pottery****Egyptian pottery****Nile silt clay*****Egyptian fine ware***

No. 1: juglet (Fig. 55), Inv. No. P7018A (Drawing No. 0905)

BP	Nile B ₂	W ₂	base finished on the wheel	re.	2
----	---------------------	----------------	----------------------------	-----	---

Base (1/1) and body sherd; bulb base (R₃). Md: 4.00 + x cm; Bd: 2.00 cm; Wd: 0.45 cm; H₁: 1.30 + x cm. Surface colour: 2.5YR 4/4 reddish brown slip. Break: 2.5YR 4/1 dark reddish grey interior; 2.5YR 4/4 reddish brown exterior. Surface treatment: polished, low lustre.

Household ware

No. 2: bowl (Fig. 55), Inv. No. C-1152 [002]

Uncoated	Nile B ₂	W ₂
----------	---------------------	----------------

Rim sherd; incurved walls, everted direct rim. Rd: 22.00 cm 1/16; Wd: 0.75 cm; H₁: 2.80 + x cm; smoothed on the wheel; eroded.

No. 3: carinated bowl (Fig. 55), Inv. No. C-1152 [001]

Uncoated	Nile B ₂	W ₂
----------	---------------------	----------------

Rim sherd; carinated walls, everted direct rim. Rd: 20.00 cm 1/16; Wd: 0.75 cm; H₁: 3.50 + x cm; smoothed on the wheel; eroded.

II.- Finds***Personal object***

No. 4: ring (Fig. 55), Inv. No. F0277 (Drawing No. 0442). Complete; bronze; melted. 2.40 (diameter) x 2.00 cm. SCA No. 4022. *Find No. 007.*

Object of unknown use

No. 5: fragment of an object, Inv. No. F0308A. Faience. 1.20 x 1.10 x 0.60 cm; colour: 5GY 6/1 greenish grey. *Find No. 008.*

Product

No. 6: faience slag, Inv. No. F0781A.

L1091**Finds*****Religion***

No. 1: scarab (Plate 7), Inv. No. F0274. Complete; faience; moulded. 0.78 cm x 0.65 cm x 0.4 cm; 10YR 8/4 very pale brown. Description: an incised hieroglyphic inscription, *mn-hpr-r^c*, inside an enclosure on the base. SCA No. 1038. *Find No. 009.*

Personal object

No. 2: bead, Inv. No. F0275A (Drawing No. 0502). Complete; faience; moulded. 0.30 x 0.20 cm; colour: Chart 2 for gley 5/1 greenish grey. Cylindrical shape; perforation: 1 mm. *Find No. 010.*

L1094 (Fig. 56)**I.- Pottery**

Egyptian pottery**Nile silt clay****Egyptian painted ware***Black on Red slip ware***No. 1: bowl (Fig. 56), Inv. No. P1130A (Drawing No. 0525)**

RSMO	Nile E ₁	W ₂	---	ox.	2
------	---------------------	----------------	-----	-----	---

Body fragment; [pointed base]. Md: 22.00 + x cm; Wd: 0.80 cm; H₁: 9.00 + x cm. Surface colour: slip, 7.5YR 6/3 light red outside and 2.5YR 4/4 reddish brown inside. Break: 7.5YR 5/4 brown. Technical details: throwing lines outside and sharp ridges above the base. Decoration: a pattern of five horizontally painted bands inside, 3 mm wide, 2.5YR 4/1 dark reddish grey. Surface treatment: smoothed on the wheel.

Household ware**No. 2: bowl, Inv. No. C-1182 (2) [001]**

Uncoated	Nile B ₂	---
----------	---------------------	-----

Rim sherd; very small.

No. 3: jar (Fig. 56), Inv. No. C-1182 [002]

Uncoated	Nile B ₂	W ₂
----------	---------------------	----------------

Rim sherd; inverted direct rim, round lip. Rd: 18.00 cm 5/32; Wd: 1.10 cm; H₁: 8.30 + x cm; throwing lines inside; smoothed on the wheel; eroded.

No. 4: jar (Fig. 56), Inv. No. C-1182 [001]

Uncoated	Nile B ₂	W ₂
----------	---------------------	----------------

Rim sherd; everted direct rim, round lip. Rd: 10.00 cm 5/32; Wd: 0.85 cm; H₁: 4.60 + x cm; throwing lines inside; smoothed on the wheel; eroded.

No. 5: jar, Inv. No. C-1182 [004]

Uncoated	Nile B ₂	W ₂
----------	---------------------	----------------

Base fragment; pointed base. Wd: 0.50 cm; H₁: 4.60 + x cm; throwing lines inside and outside; smoothed on the wheel. Another, 1/1, eroded.

II.- Finds**Tool****No. 6: sharpener, Inv. No. F0305A. Fragmentary; pumice. 8.00 x 4.20 x 4.30 cm; grooves from sharpening on both sides.****L1095 (Fig. 57)****I.- Pottery****Egyptian pottery****Nile silt clay****Household ware****No. 1: bowl (Fig. 57), Inv. No. C-1211 [003]**

Uncoated	Nile B ₂	W ₂
----------	---------------------	----------------

Rim sherd; everted articulated interior and exterior lip, modelled lip. Rd: 18.00 cm 3/32; Wd: 0.60 cm; H₁: 2.60 + x cm. Throwing lines inside and outside; smoothed on the wheel.

No. 2: cup (Fig. 57), Inv. No. C-1211 [007]

Uncoated	Nile B ₂	W ₂
----------	---------------------	----------------

Rim sherd; vertical direct rim. Rd: 8.00 cm 3/32; Wd: 0.35 cm; H₁: 2.20 + x cm. Throwing

lines inside.; smoothed on the wheel; eroded on the rim.

No. 3: jar (Fig. 57), Inv. No. C-1211 [006]

Uncoated	Nile B ₂	W ₂
----------	---------------------	----------------

Rim sherd; vertical direct rim. Rd: 13.00 cm 1/16; Wd: 0.55 cm; H₁: 4.50 + x cm. Throwing lines inside; smoothed on the wheel. Rd: 10.00 cm 1/8.

Pottery with special functions

No. 4: "pigeon pot" (Fig. 57), Inv. No. C-1211 [008]

Uncoated	Nile B ₂	W ₂	W
----------	---------------------	----------------	---

Base fragment; flat base. Bd: 6.00 cm 1/4; Wd: 0.80 cm; H₁: 4.00 + x cm. Throwing lines inside; smoothed on the wheel.

Bodys sherds, Nile B₂, Nile C₁, Nile C₂.

I.- Finds

Weight

No. 5: net weight (Fig. 57), Inv. No. F0303A (Drawing No. 0690). Fragmentary; lead; melting. 1.90 x 1.80 x 1.80 cm; U-shape. Function: fishing.

Some remarks concerning the operations from Area II West

1. Several ditches or channels found in the sondages had the same orientation as Building C. If they are the foundation trenches of light structures which left almost no other traces, it is clear then there was some order in the use of space at Tell el-Ghaba. This is also the case in Area I.
2. The industrial oven L1039 functioned inside casemate L1018 of Building C, and its drainage runnel was covered by fallen mud bricks (L1026), so that it seems to have been in use at the same time as the construction. A later industrial oven was built in this same spot, since another drainage for fused matter (L1038) was identified. For the time being, it is not clear whether it was contemporary or later than Building C.

WEST AND EAST SECTIONS

**Archaeological material from
the destruction layer L1001 = L1004 (Fig. 58)**

I.- Pottery

a) Egyptian pottery

Nile silt clay

Fine ware

No. 1: juglet, Inv. No. P7021A (Drawing No. 0905)

RP	Nile E ₂	Ha ₂	---	ox.	2-3
----	---------------------	-----------------	-----	-----	-----

Handle fragment. Hd: 0.95 x 0.90 cm. Surface colour: 10R 4/8 red slip. Break: 5YR 5/4 reddish brown-5/6 yellowish red. Technical details: rolled handle. Surface treatment: polished, low lustre.

Egyptian painted ware***Black on Red slip ware*****No. 2: jug (Fig. 58:1), Inv. No. P1164A (Drawing No. 0934)**BSMO | Nile B₂ | W₂ | W | re. | 2

Base and body fragment; round base. Md: 8.00 + x cm; Wd: 0.45 cm; H₁: 3.00 x cm. Surface colour: 2.5YR 5/4 reddish brown slip. Break: 2.5YR 4/6 red exterior; 4/1 dark reddish grey interior. Technical details: made in parts; throwing lines inside. Decoration: three horizontally painted bands on the base outside, 5YR 3/1 very dark grey. Surface treatment: smoothed on the wheel. Smoked inside and outside.

Egyptian household ware**No. 3: bowl (Fig. 58:1), Inv. No. C-1007 [003]**Uncoated | Nile E₂ | W₂Rim sherd; inverted direct rim. Rd: 14.00 cm 1/16; Wd: 0.58 cm; H₁: 1.65 + x cm.**No. 4: bowl (Fig. 58:1), Inv. No. C-1002 [003]**Uncoated | Nile E₂ | W₂Rim sherd; inverted articulated interior and exterior rim, modelled lip. Rd: 16.00 cm 3/32; Wd: 0.60 cm; H₁: 3.35 + x cm.**No. 5: bowl (Fig. 58:1), Inv. No. C-1192 [001]**Uncoated | Nile B₂ | W₂

Rim sherd; everted direct rim. Rd: 26.00 cm 1/8; Wd: 0.70 cm; H₁: 4.90 + x cm; smoothed on the wheel; salt incrustated. Others: Nile B₂, Rd: 21.00 cm 1/8, Rd: 22.00 cm 3/32, Rd: 24.00 cm 1/16, Rd: 25.00 cm 1/8, Rd: 26.00 cm 1/16. Nile C₁, Rd: 27.00 cm 3/32. Large bowls, Nile B₂, Rd: 30.00 cm 3/32, Rd: 33.00 cm 3/32, Rd: 40.00 cm 3/32. Nile C₁, Rd: 30.00 cm 1/4, Rd: 35.00 cm 1/16, Rd: 37.00 cm 3/16, Rd: 38.00 cm 1/32, Rd: 44.00 cm 1/16. Nile C₂, Rd: 44.00 cm 1/32.

No. 6: bowl (Fig. 58:1), Inv. No. C-1158 [005]Uncoated | Nile C₁ | W₂Rim sherd; everted direct flaring rim. Rd: 23.00 cm 1/16; Wd: 0.70 cm; H₁: 3.80 + x cm. Throwing lines inside; smoothed on the wheel; eroded. Another, Rd: 38.00 cm 1/32.**No. 7: bowl (Fig. 58:1), Inv. No. C-1115 [038]**Uncoated | Nile B₂ | W₂

Rim sherd; everted articulated exterior rim. Rd: 19.00 cm 7/32; Wd: 0.80 cm; H₁: 3.60 + x cm; smoothed on the wheel; smoked; eroded inside and outside; salt incrustated. Others, Rd: 15.00 cm 1/32, Rd: 16.00 cm 1/16, Rd: 16.00 cm 3/32, Rd: 17.00 cm 1/16, Rd: 18.00 cm 1/16, Rd: 21.00 cm 1/16, Rd: 23.00 cm 1/16, Rd: 26.00 cm 3/4, Rd: 40.00 cm 1/16. Nile E₂, Rd: 18.00 cm 3/32, Rd: 19.00 cm 1/16, Rd: 30.00 cm 3/32.

No. 8: bowl (Fig. 58:1), Inv. No. C-1104 [021]Uncoated | Nile B₂ | W₂Rim sherd; everted articulated exterior rim, trimmed lip. Rd: 16.00 cm 1/16; Wd: 1.00 cm; H₁: 2.10 + x cm; eroded.**No. 9: bowl (Fig. 58:1), Inv. No. C-1115 [002]**Uncoated | Nile B₂ | W₂Rim sherd; everted articulated simmetrical rim, trimmed lip. Rd: 27.00 cm 5/32; Wd: 1.00 cm; H₁: 7.20 + x cm; smoothed on the wheel; salt incrustated.

No. 10: bowl (Fig. 58:1), Inv. No. C-1172 [005]Uncoated Nile B₂ W₂

Rim sherd; everted articulated interior rim, modelled lip. Rd: 44.00 cm 1/16; Wd: 1.00 cm; H₁: 4.00 + x cm; smoothed on the wheel; eroded. Others, Rd: 22.00 cm 1/32, Rd: 30.00 cm 1/16. Nile C₁, Rd: 32.00 cm 3/32.

No. 11: carinated bowl (Fig. 58:1), Inv. No. C-1172 [003]Uncoated Nile B₂ W₂

Rim sherd; carinated walls; everted articulated interior rim, modelled lip. Rd: 18.00? cm 1/32; Wd: 0.50 cm; H₁: 3.30 + x cm; smoothed on the wheel; eroded outside.

No. 12: bowl, Inv. No. C-1115 [036]Uncoated Nile B₂ W₂ W

Base fragment; round base. Wd: 1.10 cm; H₁: 4.70 + x cm; smoothed on the wheel; eroded. Others, 8 bases.

No. 13: bowl, Inv. No. C-1104 [028]Uncoated Nile B₂ W₂ W

Base fragment; round base. Wd: 0.60 cm; H₁: 3.00 + x cm; smoothed on the wheel; smoked. Another, 1 base.

No. 14: deep bowl (Fig. 58:1), Inv. No. C-1104 [014]Uncoated Nile C₁ W₂

Rim sherd; slightly incurved walls; inverted direct rim. Rd: 13.00 cm 1/16; Wd: 0.80 cm; H₁: 3.50 + x cm; eroded. Another, Rd: 11.00 cm 3/32.

No. 15: cooking pots (Fig. 58:2), Inv. No. P7025A (Drawing No. 0906)Uncoated Nile E₂ W₂ --- ox. 2

Rim sherd, 1/8; exterior lip. Rd: 17.00 cm; Md: 26.00 + x cm; Wd: 0.90 cm; H₁: 4.10 + x cm. Surface colour: 5YR 5/4 reddish brown. Break: 2.5YR 4/8 red. Surface treatment: smoothed on the wheel. Eroded inside.

No. 16: goblet (Fig. 58:2), Inv. No. P7026A (Drawing No. 0906)RS Nile B₂ W₂ --- ox. 2

Body fragment. Md: 6.50 + x cm; Wd: 0.35 cm; H₁: 7.30 + x cm. Surface colour: 10R 5/6 red slip. Break: 2.5YR 5/1 reddish grey core; 2.5YR 5/6 red oxidation zones. Technical details: fine ridges inside; made in parts. Surface treatment: smoothed on the wheel.

No. 17: goblet (Fig. 58:2), Inv. No. P0212A (Drawing No. 0149)RS Nile clay W₁ [W] ox. 2

Foot fragment. Fd: 3.50 cm 1/1; Wd: 0.55 cm; H₄: 3.50 cm. Surface colour: 10YR 6/8 light red slip. Break: 10R 4/8 red. Surface treatment: smoothed on the wheel.

No. 18: cup (Fig. 58:2), Inv. No. C-1171 [003]Uncoated Nile B₂ W₂

Rim sherd; everted direct rim. Rd: 10.00 cm 1/8; Wd: 0.50 cm; H₁: 2.00 + x cm. Throwing lines inside and outside; smoothed on the wheel; salt incrustated.

No. 19: juglet, Inv. No. C-1165 (2) [001]Uncoated Nile B₂ W₂

Base fragment; flat base Rd: 3.00 cm 1/2; Wd: 0.30 cm; H₁: 1.70 + x cm. Throwing lines

inside; smoothed on the wheel; eroded.

No. 20: pilgrim flask, Inv. No. P7056A (Drawing No. 0926)

Uncoated	Nile B ₂	Ha ₂	---	ox.	2
----------	---------------------	-----------------	-----	-----	---

Neck fragment. Nd: 1.50 cm; Wd: 0.45 cm; H₃: 0.80 + x cm. Surface colour: 5YR 5/3 reddish brown. Break: 5YR 5/6 yellowish red. Technical details: neck opened with a tool. Surface treatment: smoothed.

No. 21: globular jar (Fig. 58:2), Inv. No. C-1104 [020]

Uncoated	Nile B ₂	W ₂
----------	---------------------	----------------

Rim sherd; vertical direct rim. Rd: 7.00 cm 1/8; Wd: 0.60 cm; H₁: 5.00 + x cm. Throwing lines inside; smoothed on the wheel. Another, Rd: 10.00 cm 3/32.

No. 22: globular jar (Fig. 58:2), Inv. No. C-1104 (2) [002]

Uncoated	Nile B ₂	W ₂
----------	---------------------	----------------

Rim and body fragment; globular shape, everted modelled rim. Rd: 12.00 cm 1/4; Wd: 0.70 cm; H₁: 6.65 + x cm. Throwing lines inside; smoothed on the wheel.

No. 23: globular jar (Fig. 58:2), Inv. No. C-1115 [014]

Uncoated	Nile B ₂	W ₂
----------	---------------------	----------------

Rim sherd; everted articulated interior and exterior rim, flattened lip. Rd: 10.00 cm 3/32; Nd: 1.30 cm; Wd: 0.50 cm; H₁: 3.50 + x cm. Throwing lines inside and outside; smoothed on the wheel; salt incrustated.

No. 24: jar (Fig. 58:3), Inv. No. C-1172 [015]

Uncoated	Nile B ₂	W ₂
----------	---------------------	----------------

Rim sherd; inverted articulated exterior rim, modelled lip. Rd: 13.00 cm 1/4; Wd: 1.50 cm; H₁: 4.70 + x cm. Throwing lines inside; smoothed on the wheel.

No. 25: jar (Fig. 58:3), Inv. No. C-1104 [002]

Uncoated	Nile B ₂	W ₂
----------	---------------------	----------------

Rim sherd; inverted direct rim. Rd: 10.00 cm 3/16; Wd: 0.80 cm; H₁: 3.20 + x cm. Throwing lines inside; smoothed on the wheel; eroded outside. Others, Rd: 10.00 cm 1/4, Rd: 11.00 cm 5/32, Rd: 12.00 cm 3/32, Rd: 13.00 cm 3/16.

No. 26: jar (Fig. 58:3), Inv. No. C-1104 [019]

Uncoated	Nile E ₂	W ₂
----------	---------------------	----------------

Rim sherd; inverted articulated exterior rim, rolled lip. Rd: 12.00 cm 3/16; Wd: 1.00 cm; H₁: 5.20 + x cm. Throwing lines inside; smoothed on the wheel; salt incrustated and eroded inside and outside. Others, Rd: 8.00 cm 3/16, Rd: 12.00 cm 1/2, Rd: 12.00 cm 1/8, Rd: 14.00 cm 1/8, Rd: 17.00 cm 1/2.

No. 27: jar (Fig. 58:3), Inv. No. C-1007 [002]

Uncoated	Nile B ₂	W ₂
----------	---------------------	----------------

Rim sherd; vertical articulated exterior rim, modelled lip. Rd: 16.00 cm 3/32; Wd: 0.70 cm; H₁: 3.20 + x cm.

No. 28: jar (Fig. 58:3), Inv. No. C-1172 [008]

Uncoated	Nile B ₂	W ₂
----------	---------------------	----------------

Rim sherd; vertical direct rim. Rd: 11.00 cm 5/32; Wd: 0.80 cm; H₁: 3.40 + x cm. Throwing lines inside; smoothed on the wheel; eroded. Others, Rd: 8.00 cm 3/8, Rd: 9.00

cm 3/16, Rd: 10.00 cm 1/4, Rd: 11.00 cm 1/8, Rd: 13.00 cm 1/4, Rd: 14.00 cm 3/32.

No. 29: jar (Fig. 58:3), Inv. No. C-1115 [034]

Uncoated	Nile B ₂	W ₂ + Ha ₂
----------	---------------------	----------------------------------

Rim and handle fragment; vertical loop handle; vertical rim direct rim. Rd: 14.00 cm 3/16; Wd: 1.10 cm; H₁: 12.00 + x cm; Hd: 3.00 x 2.50 cm; oval in section; 1; single strap. Throwing lines inside and outside; smoothed on the wheel; salt incrustated.

No. 30: jar (Fig. 58:3), Inv. No. C-1190 [006]

Uncoated	Nile B ₂	W ₂
----------	---------------------	----------------

Rim sherd; everted direct rim. Rd: 10.00 cm 1/16; Wd: 0.60 cm; H₃: 4.20 + x cm. Throwing lines inside; smoothed on the wheel. Others, Rd: 9.00 cm 3/8, Rd: 10.00 cm 3/8, Rd: 11.00 cm 1/4, Rd: 12.00 cm 1/8, Rd: 13.00 cm 1/8, Rd: 14.00 cm 1/16, Rd: 15.00 cm 3/32, Rd: 17.00 cm 3/32.

No. 31: jar (Fig. 58:3), Inv. No. C-1115 [004]

Uncoated	Nile B ₂	W ₂
----------	---------------------	----------------

Rim sherd; everted articulated exterior rim, modelled lip. Rd: 16.00 cm 7/32; Wd: 0.90 cm; H₁: 5.50 + x cm. Throwing lines inside and outside; smoothed on the wheel; eroded on the rim. Others, Rd: 9.00 cm 3/16, Rd: 10.00 cm 7/32.

No. 32: storage jar (Fig. 58:4), Inv. No. P7053A (Drawing No. 0925)

Uncoated	Nile B ₂ s.	W ₂	---	ox.	2
----------	------------------------	----------------	-----	-----	---

Rim and shoulder fragment, swelling of the handle; exterior lip. Rd: 18.00 cm 1/8; Md: 22.50 + x cm; Wd: 1.05 cm; H₁: 15.50 + x cm. Surface colour: 2.5YR 5/4 reddish brown. Break: 2.5YR 5/6 red. Technical details: made in parts; applied handle. Surface treatment: smoothed on the wheel.

No. 33: storage jar (Fig. 58:4), Inv. No. C-1115 [029]

Uncoated	Nile B ₂	W ₂
----------	---------------------	----------------

Rim sherd; inverted articulated interior and exterior rim, flattened lip. Rd: 29.00 cm 3/32; Wd: 0.90 cm; H₁: 5.50 + x cm. Throwing lines inside and outside; smoothed on the wheel; eroded inside.

No. 34: storage jar (Fig. 58:4), Inv. No. C-1104 [006]

Uncoated	Nile B ₂	W ₂
----------	---------------------	----------------

Rim sherd; inverted articulated interior and exterior rim, rolled lip. Rd: 20.00 cm 3/16; Wd: 1.00 cm; H₁: 3.50 + x cm. Throwing lines inside; smoothed on the wheel; salt incrustated inside; eroded outside.

No. 35: storage jar, Inv. No. C-1115 [041]

Uncoated	Nile B ₂	W ₂
----------	---------------------	----------------

Rim sherd; inverted direct thickened rim, flattened. Rd: 30.00 cm 1/8; Wd: 1.10 cm; H₁: 8.00 + x cm. Throwing lines inside and outside; smoothed on the wheel; eroded.

No. 36: storage jar (Fig. 58:4), Inv. No. C-1104 [026]

Uncoated	Nile C ₁	W ₂
----------	---------------------	----------------

Rim sherd and handle fragment; inverted articulated exterior rim, rolled lip. Rd: 36.00 cm 1/16; Wd: 0.80 cm; H₁: 4.00 + x cm. Throwing lines inside; smoothed on the wheel; eroded.

No. 37: storage jar (Fig. 58:4), Inv. No. C-1190 [002]Uncoated Nile B₂ W₂

Rim sherd; inverted articulated interior rim, rolled lip. Rd: 27.00 cm 1/8; Wd: 0.90 cm; H₁: 5.50 + x cm. Throwing lines inside; smoothed on the wheel; eroded outside. Another, Rd: 24.00 cm 1/16.

No. 38: storage jar (Fig. 58:4), Inv. No. C-1115 [044]Uncoated Nile B₂ W₂

Rim sherd; inverted articulated simmetrical rim, rounded lip. Rd: 25.00 cm 1/16; Wd: 0.90 cm; H₁: 3.50 + x cm. Throwing lines inside and outside; smoothed on the wheel; eroded; salt incrustated.

No. 39: storage jar (Fig. 58:4), Inv. No. C-1115 [031]Uncoated Nile B₂ W₂

Rim sherd; inverted articulated exterior rim, flattened lip. Rd: 22.00 cm 1/16; Wd: 0.80 cm; H₁: 3.00 + x cm. Throwing lines inside and outside; smoothed on the wheel.

No. 40: storage jar (Fig. 58:4), Inv. No. C-1104 [030]Uncoated Nile B₂ W₂

Rim sherd; inverted articulated interior and exterior rim, modelled lip. Rd: 30.00 cm 1/16; Wd: 1.10 cm; H₁: 5.50 + x cm. Throwing lines inside; smoothed on the wheel; eroded.

No. 41: storage jar (Fig. 58:4), Inv. No. C-1115 [032]Uncoated Nile B₂ W₂

Rim sherd; vertical direct rim. Rd: 20.00 cm 1/16; Wd: 0.60 cm; H₁: 2.50 + x cm. Throwing lines inside and outside. smoothed on the wheel.

No. 42 : storage jar (Fig. 58:5), Inv. No. C-1172 [012]Uncoated Nile B₂ W₂

Rim sherd; vertical articulated exterior rim, modelled lip. Rd: 20.00 cm 3/32; Wd: 0.80 cm; H₁: 6.40 + x cm. Throwing lines inside; smoothed on the wheel; eroded inside and outside. Others, Rd: 20.00 cm 3/32, Rd: 20.00 cm 3/32.

No. 43: storage jar (Fig. 58:5), Inv. No. C-1190 [001]Uncoated Nile B₂ W₂

Rim sherd; inverted articulated exterior rim, trimmed lip. Rd: 26.00 cm 3/32; Wd: 1.00 cm; H₁: 8.10 + x cm. Throwing lines inside; smoothed on the wheel; eroded. Others, Rd: 20.00 cm 3/32. Nile C₁, Rd: 24.00 cm 3/32.

No. 44: storage jar (Fig. 58:5), Inv. No. C-1115 [001]Uncoated Nile B₂ W₂

Rim, neck and shoulder fragment; everted direct rim (ledge rim). Rd: 25.00 cm 5/32; Wd: 1.00 cm; H₁: 6.00 + x cm. Throwing lines inside and outside; smoothed on the wheel; salt incrustated.

No. 45: storage jar (Fig. 58:5), Inv. No. C-1117 [002]Uncoated Nile B₂ W₂

Rim sherd; everted articulated exterior rim, rolled lip. Rd: 24.00 cm 1/16; Wd: 0.90 cm; H₁: 3.70 + x cm; eroded.

No. 46: storage jar (Fig. 58:5), Inv. No. C-1115 [003]

Uncoated	Nile B ₂	W ₂
----------	---------------------	----------------

Rim sherd; everted articulated simmetrical rim, trimmed lip. Rd: 24.00 cm 1/8; Wd: 1.20 cm; H₁: 3.00 + x cm. Throwing lines inside and outside; smoothed on the wheel; salt incrustated. Another, Rd: 31.00 cm 1/32.

No. 47: storage jar?, Inv. No. C-1104 [007]

Uncoated	Nile E ₂	W ₂ + Ha ₂
----------	---------------------	----------------------------------

Handle fragment; vertical loop handle from shoulder to upper body. Md: 19.00 cm 5/32; Wd: 0.80 cm; H₁: 12.00 + x cm; Hd: 2.90 x 1.70 cm; oval in section; 1; single strap. smoothed by hand. Eroded, smoked.

No. 48: jar or storage jar?, Inv. No. C-1104 [015]

Uncoated	Nile B ₂	Ha ₂
----------	---------------------	-----------------

Handle fragment; sticked vertical loop handle. Wd: 1.00 cm; H₁: 5.30 + x cm; Hd: 2.90 x 3.00 cm; slightly round in section; 1; single strap. Smoothed by hand. Others, Hd: 3.00 x 2.00 cm, Hd: 4.00 x 2.00 cm, Hd: 3.00 x 2.10 cm, Hd: 3.20 x 1.90 cm, Hd: 3.40 x 1.50 cm, Hd: 2.30 x 1.50 cm, Hd: 3.10 x 1.80 cm, Hd: 3.50 x 2.00 cm, Hd: 3.00 x 2.30 cm, Hd: 3.50 x 2.10 cm, Hd: 3.30 x 2.60 cm, Hd: 4.00 x 1.90 cm. Nile C₁, Hd: 3.00 x 2.10 cm, Hd: 4.30 x 3.00 cm. Nile E₂, Hd: 2.50 x 2.00 cm, Hd: 3.00 x 1.90 cm. Upper part of the handle, Nile B₂, Hd: 3.30 x 2.70 cm, Hd: 2.80 x 2.50 cm.

Pottery with special functions

No. 49: bakery tray (Fig. 58:5), Inv. No. P1024A (Drawing No. 0369)

Uncoated	Nile E ₂	W ₁	Ha	med.	2
----------	---------------------	----------------	----	------	---

Complete, fragmentary; everted articulated exterior rim. Rd: 18.00 cm 1/8; Bd: 16.00 cm 5/32; Wd: 1.00-1.60 cm; H₁: 3.80 cm. VI: 474. Surface colour: 10R 5/6 red. Break: 10YR 3/2 very dark greyish brown. Surface treatment: smoothed. Eroded inside and outside.

No. 50: bakery tray (Fig. 58:5), Inv. No. P1030A (Drawing No. 0385)

Uncoated	Nile C ₂	W ₁	Ha	med.	2
----------	---------------------	----------------	----	------	---

Complete, fragmentary; everted articulated exterior rim. Rd: 20.00 cm 7/32; Bd: 18.00 cm 3/16; Wd: 1.30-1.45 cm; H₁: 4.70 cm. VI: 426. Surface colour: 10R 5/8 red. Break: 10R 5/6 red. Surface treatment: smoothed. Smoked surface; deformed.

No. 51: bakery tray (Fig. 58:5), Inv. No. P1033A (Drawing No. 0378)

Uncoated	Nile C ₂	W ₁	Ha	med.	2
----------	---------------------	----------------	----	------	---

Complete, fragmentary; everted direct rim. Rd: 22.00 cm 1/16; Bd: 20.00 cm 1/8; Wd: 1.50-2.00 cm; H₁: 4.85 cm. VI: 454. Surface colour: 2.5YR 6/4 light reddish brown. Break: 2.5YR dark reddish brown core; 2.5YR 5/4 reddish brown oxidation zones. Salt incrustated, eroded surface and part of the rim.

No. 52: bakery tray (Fig. 58:5), Inv. No. P1034A (Drawing No. 0379)

Uncoated	Nile C ₂	W ₁	W ₁	Ha	ox.	2
----------	---------------------	----------------	----------------	----	-----	---

Complete, fragmentary; everted direct rim. Rd: 20.00 cm 3/32; Bd: 18.00 cm 1/8; Wd: 1.30 cm; H₁: 4.85 cm. VI: 412. Surface colour: 2.5YR 5/6 red. Break: 2.5YR 4/6 red. Surface treatment: uneven. Eroded rim and base; smoked base? Others, Rd: 26.00 cm 1/8 and Bd: 24.00 cm 1/8; Rd: 24.00 cm 1/8 and Bd: 12.00 cm 1/8. Only rims: Rd: 26.00 cm 1/8, Rd: 22.00 cm; Rd: 19.00 cm 3/32. Only base: Bd: 18.00 cm 5/32.

No. 53: bakery tray (Fig. 58:6), Inv. No. P1035A (Drawing No. 0369)

Uncoated	Nile B ₂	W ₁	Ha	ox.	2
----------	---------------------	----------------	----	-----	---

Complete, fragmentary; everted direct rim. Rd: 18.00 cm 1/4; Bd: 16.00 cm 1/4; Wd: 1.60-1.70 cm; H₁: 3.00 cm. VI: 600. Surface colour: 10R 4/8 red. Break: 10R 5/8 red. Surface treatment: smoothed. Salt incrustated. Others, Rd: 24.00 cm 5/32 and Bd: 20.00 cm 5/32.

No. 54: bakery tray, Inv. No. P1036A (Drawing No. 0379)

Uncoated	Nile B ₂	W ₁	Ha	med.	2
----------	---------------------	----------------	----	------	---

Complete, fragmentary; everted direct rim. Rd: 22.00 cm 5/32; Bd: 20.00 5/32; Wd: 1.35-1.45 cm; H₁: 3.45-4.00 cm. VI: 550. Surface colour: 2.5YR 6/6 light red. Break: 2.5YR 6/8 light red core; 5YR 5/6 yellowish red oxidation zones. Technical details: finger prints on the base. Surface treatment: smoothed. Eroded base.

No. 55: bakery tray (Fig. 58:6), Inv. No. P1025A (Drawing No. 0372)

Uncoated	Nile C ₂	W ₁	Ha	ox.	2
----------	---------------------	----------------	----	-----	---

Complete, fragmentary; everted articulated exterior rim. Rd: 22.00 cm 1/8; Bd: 20.00 cm 7/32; Wd: 1.60 cm; H₁: 4.20 cm. VI: 524. Surface colour: 5YR 5/6 yellowish red. Break: 10R 4/8 red. Technical details: finger prints on the base. Surface treatment: uneven.

No. 56: bakery tray (Fig. 58:6), Inv. No. P1026A (Drawing No. 0379)

Uncoated	Nile C ₂	W ₁	H	ox.	2
----------	---------------------	----------------	---	-----	---

Complete, fragmentary; everted articulated exterior rim. Rd: 22.00 cm 7/32; Bd: 20.00 cm 7/32; Wd: 1.80-1.90 cm; H₁: 4.50 cm. 489. Surface colour: 2.5YR 6/6 light red. Break: 2.5YR 5/6 red. Technical details: pinched base. Surface treatment: uneven. Eroded.

No. 57: bakery tray (Fig. 58:6), Inv. No. P1071A (Drawing No. 0391)

Uncoated	Nile B ₂	W ₁	Ha	ox.	2
----------	---------------------	----------------	----	-----	---

Complete, fragmentary; everted direct rim. Rd: 16.00 cm 7/32; Bd: 14.00 cm 7/32; Wd: 1.40 cm; H₁: 1.70-2.00 cm. VI: 800. Surface colour: 2.5YR 5/6 red. Break: 2.5YR 4/4 reddish brown core; 2.5YR 6/8 light red oxidation zones. Surface treatment: uneven. Eroded base and rim.

No. 58: bakery tray (Fig. 58:6), Inv. No. P1307A (Drawing No. 0652)

Uncoated	Nile C ₂ s.	W ₁	H	ox.	2
----------	------------------------	----------------	---	-----	---

Complete, fragmentary; everted direct rim. Rd: 25.00 cm 7/32; Bd: 22.00 cm 3/16; Wd: 2.00 cm; H₁: 4.00 cm. VI: 600. Surface colour: 10R 5/8 red. Break: 10R 5/6 red. Surface treatment: uneven.

No. 59: bakery tray, Inv. No. P1054A (Drawing No. 0436)

Uncoated	Nile B ₂ /C ₁	W ₁	Ha	med.	2
----------	-------------------------------------	----------------	----	------	---

Complete, fragmentary; everted direct rim. Rd: 19.00 cm 3/32; Bd: 18.00 cm? 1/16; Wd: 1.20 cm; H₁: 3.20 cm. VI: 594. Surface colour: 5YR 6/6 reddish yellow. Break: 5YR 4/1 dark grey core; 2.5YR 4/6 red oxidation zones. Surface treatment: uneven. Eroded.

No. 60: bakery tray (Fig. 58:6), Inv. No. P1056A (Drawing No. 0434)

Uncoated	Nile C ₂	W ₁	Ha	re.	2
----------	---------------------	----------------	----	-----	---

Complete, fragmentary; everted direct rim. Rd: 24.00 cm 3/32; Bd: 22.40 cm 1/8; H₁: 5.30 cm. VI: 453. Surface colour: 7.5YR 6/4 light brown. Break: 7.5YR 3/1 very dark grey core; 10R 5/3 weak red oxidation zones. Surface treatment: uneven. Smoked inside (used as a lid?); eroded base and rim.

No. 61: bakery tray (Fig. 58:6), Inv. No. P1074A (Drawing No. 0396)

Uncoated	Nile B ₂ c.	W ₁	Ha	med.	2
----------	------------------------	----------------	----	------	---

Complete, fragmentary; everted direct rim. Rd: 20.00 cm 3/16; Bd: 18.00 cm 3/16; Wd: 0.90-1.20 cm; H₁: 4.40 cm. VI: 455. Surface colour: 5YR 5/6 yellowish red. Break: 5YR 4/3 reddish brown. Surface treatment: uneven. Eroded.

No. 62: bakery tray (Fig. 58:7), Inv. No. P1075A (Drawing No. 0396)

Uncoated	Nile B ₂	W ₁	Ha	ox.	2
----------	---------------------	----------------	----	-----	---

Complete, fragmentary; everted direct rim. Rd: 20.00 cm 5/32; Bd: 18.00 cm 5/32; Wd: 1.20 cm; H₁: 4.40 cm. VI: 455. Surface colour: 2.5YR 5/6 red. Break: 2.5YR 4/4 reddish brown core; 2.5YR 5/8 red oxidation zones. Technical details: throwing lines inside the rim; finger prints on the base (pinched base). Surface treatment: smoothed on the wheel. Salt incrustations on the base.

No. 63: bakery tray (Fig. 58:7), Inv. No. P1076A (Drawing No. 0433)

Uncoated	Nile B ₂	W ₁	Ha	ox.	2
----------	---------------------	----------------	----	-----	---

Complete, fragmentary; everted direct rim. Rd: 20.00 cm 3/16; Bd: 18.00 cm 3/16; Wd: 1.40 cm; H₁: 4.20 cm. Surface colour: 2.5YR 5/6 red. Break: 2.5YR 5/8 red. Surface treatment: smoothed by hand. Eroded base; salt incrustated inside.

No. 64: bakery tray (Fig. 58:7), Inv. No. P1078A (Drawing No. 0390)

Uncoated	Nile C ₂	W ₁	Ha	med.	2
----------	---------------------	----------------	----	------	---

Complete, fragmentary; everted direct rim. Rd: 20.00 cm? 3/16; Bd: 18.00 cm 3/16; Wd: 1.00-1.65 cm; H₁: 3.10 cm. VI: 645. Surface colour: 10R 5/6 red. Break: 10R 4/4 weak red core; 10R 3/3 dusky red oxidation zones. Surface treatment: uneven. Eroded.

No. 65: bakery tray (Fig. 58:7), Inv. No. P1083A (Drawing No. 0390)

Uncoated	Nile B ₂	W ₁	Ha	med.	2
----------	---------------------	----------------	----	------	---

Complete, fragmentary; everted direct rim. Rd: 20.00 cm 3/32; Bd: 16.40 cm 3/32; Wd: 1.40 cm; H₁: 3.40 cm. VI: 588. Surface colour: 5YR 5/4 reddish brown. Break: 10R 4/8 red. Surface treatment: smoothed. Eroded base.

No. 66: bakery tray (Fig. 58:7), Inv. No. P1085A (Drawing No. 0389)

Uncoated	Nile B ₂	W ₁	Ha	med.	2
----------	---------------------	----------------	----	------	---

Complete, fragmentary; everted direct rim. Rd: 18.00 cm 3/32; Bd: 18.40 cm 3/32; Wd: 1.20 cm; H₁: 4.00 cm. VI: 450. Surface colour: 7.5YR 6/4 light brown. Break: 7.5YR 4/6 strong brown core; 7.5YR 3/2 dark brown oxidation zones. Surface treatment: uneven. Eroded rim; salt incrustation on the base.

No. 66bis: bakery tray (Fig. 58:7), Inv. No. P1077A (Drawing No. 0433)

Uncoated	Nile C ₂	W ₁	---	ox.	2
----------	---------------------	----------------	-----	-----	---

Rim sherd; everted direct rim. Rd: 20.00 cm 1/8; H₁: 3.60 + x cm. Surface colour: 2.5YR 5/6 red. Break: 10R 4/4 weak red. Surface treatment: smoothed. Eroded.

Egyptian marls

Fine ware

No. 67: juglet (Fig. 58:7), Inv. No. P0036A (Drawing No. 0935)

P	Marl F	W ₂ + Ha ₂	---	ox.	3
---	--------	----------------------------------	-----	-----	---

Neck, shoulder and handle fragment; single strap. Nd: 1.65 cm; Md: 2.70 + x cm; Wd: 0.35 cm; H₁: 3.00 + x cm; H₃: 2.50 + x cm; Hd: 0.70 x 0.70 cm. Surface colour: 7.5YR 6/4 light brown; 10R 4/6 red self slip. Break: 5YR 6/4 light reddish brown. Technical details: oblique marks in the neck to open it. Surface treatment: polished, high lustre.

No. 68: juglet (Fig. 58:7), Inv. No. P7032A (before Inv. No. P1099A. Drawing No. 0441)

Uncoated	Marl F	W ₂	---	ox.	3
----------	--------	----------------	-----	-----	---

Rim sherd, 7/32; everted articulated exterior lip. Rd: 5.50 cm; H₃: 0.50 + x cm. Surface colour: 10YR 7/2 light grey self slip. Break: 7.5YR 6/4 light brown. Technical details: throwing lines inside. Decoration: a painted band on the rim, inside and outside, 10R 5/8 red. Surface treatment: smoothed on the wheel.

Household ware

No. 69: cup (Fig. 58:8), Inv. No. P0038A (Drawing No. 0937)

Uncoated	Marl A ₄	W ₂	---	ox.	2
----------	---------------------	----------------	-----	-----	---

Rim sherd; everted direct rim. Rd: 9.00 cm 7/64; Wd: 0.35 cm; H₁: 2.80 + x cm. Surface colour: 10YR 7/3 very pale brown-2.5Y 7/3 pale yellow self slip. Break: 2.5Y 7/2 light grey self slip. Technical details: fine ridges outside and inside. Surface treatment: smoothed on the wheel.

No. 70: jar (Fig. 58:8), Inv. No. P0218A (Drawing No. 0937)

Uncoated	Marl A ₄	W ₂	---	ox.	3
----------	---------------------	----------------	-----	-----	---

Rim sherd; exterior lip, folded. Rd: 11.00 cm 1/4; Wd: 0.60 cm; H₁: 3.20 + x cm; H₃: 2.90 cm. Surface colour: 10YR 7/2 light grey self slip. Break: 5YR 6/4 light reddish brown-6/6 reddish yellow. Technical details: made in parts; a groove below the rim; fine ridges outside and inside. Surface treatment: smoothed on the wheel.

No. 71: jar (Fig. 58:8), Inv. No. P2019A (Drawing No. 0656)

Uncoated	Marl A ₄	W ₂	----	ox.	3
----------	---------------------	----------------	------	-----	---

Rim sherd; everted direct rim Rd: 5.50 cm 1/8; Wd: 0.30 cm; H₁: 1.80 + x cm. Surface colour: 2.5Y 7/3 pale yellow self slip. Break: 2.5Y 7/3 pale yellow. Technical details: throwing lines inside. Surface treatment: smoothed on the wheel.

No. 72: amphora, Inv. No. C-1104 (2) [001]

Uncoated	Marl F v.s.	W ₂			
----------	-------------	----------------	--	--	--

Rim sherd; everted direct rim. Rd: 11.00 cm 1/8; Wd: 0.50 cm; H₁: 2.60 + x cm. Throwing lines inside; smoothed on the wheel.

b) North Sinai/South Palestine pottery

Fine ware

White Painted ware

No. 73: juglet?, Inv. No. P2011A

WPMO	II.TG 08	W ₂	---	ox.	3
------	----------	----------------	-----	-----	---

Body sherd. Wd: 0.60 cm; H₁: 2.60 + x cm. Surface colour: 5YR 5/2 pinkish white slip. Break: 5YR 7/6 reddish yellow. Decoration: a painted band, 1.20 cm wide, 10YR 3/1 very dark grey. Surface treatment: polished, low lustre.

White Painted V ware

No. 74: jar, Inv. No. P0701A

WPMO	II?TG 47	W ₂	---	ox.	3
------	----------	----------------	-----	-----	---

Body fragment. Wd: 0.55 cm. Surface colour: 2.5Y 7/3 pale yellow slip. Break: 10YR 7/4 very pale brown. Decoration: two horizontally painted bands (10 and 15 mm wide) and five lines (2 mm wide), 2.5Y 2.5/1 black. Surface treatment: polished, low lustre.

Household ware

No. 75: amphora, II.TG 09, body sherds: 0.10 dm².

c) Imported pottery**Levantine fine ware***White Painted ware***No. 76: bowl (Fig. 58:8), Inv. No. P1095A** (Drawing No. 0656)

BPMO	IV.TG 38 = IV.Phoen.02	W ₂	---	ox.	3
------	------------------------	----------------	-----	-----	---

Body sherd and swelling of the handle. Wd: 0.40 cm; H₁: 1.80 + x cm. Surface colour: 10YR 8/3 very pale brown slip. Break: 5YR 6/8 reddish yellow. Decoration: painted, 7.5YR 3/2 dark brown. Surface treatment: polished, low lustre.

No. 77: juglet, Inv. No. P1082A

WPMO	IV.TG 05	Ha ₂	---	ox.	3
------	----------	-----------------	-----	-----	---

Handle fragment. Hd: 0.90 x 0.90 cm. Surface colour: 10R 8/2 pinkish white slip. Break: 2.5YR 5/8 red. Decoration: a painted line, 9 mm wide, 2.5YR 5/1 reddish grey. Surface treatment: polished, low lustre.

No. 78: jar (Fig. 58:8), Inv. No. P1053A (Drawing No. 0387)

WPMO	IV.TG 51 (= TD IV.19)	W ₂	---	ox.	3
------	-----------------------	----------------	-----	-----	---

Body sherd. Md: 16.00 cm 5/64; Wd: 0.50 cm; H₁: 3.50 + x cm. Surface colour: 5YR 7/8 reddish yellow slip. Break: 5YR 7/6 reddish yellow. Technical details: throwing lines inside. Decoration: a horizontally painted band and two lines, 9 and 1 mm wide, 5YR 3/2 dark reddish brown. Surface treatment: polished, low lustre.

*Bichrome ware***No. 79: pilgrim flask (Fig. 58:8), Inv. No. P0030A** (Drawing No. 0928)

WPBI	IV.?	W ₂	---	re.	3
------	------	----------------	-----	-----	---

Body sherd. Wd: 0.60 cm; H₁: 2.40 + x cm. Surface colour: 2.5Y 8/4 yellow slip. Break: 5YR 3/1 very dark grey. Technical details: made in two halves which are then joined. Decoration: two circular painted bands, 2.50-3.00 mm wide, 7.5YR 4/1 dark grey, and one line, 1.50 mm wide, 5YR 5/6 yellowish red. Surface treatment: polished. Smoked.

*Combine style***No. 80: bowl (Fig. 58:8), Inv. No. P0042A** (Drawing No. 0308)

RPMO/BPBI	IV?	W ₂	---	ox.	3
-----------	-----	----------------	-----	-----	---

Rim and body sherd; slightly incurved side walls; everted direct rim. Rd: 14.00 cm 5/32; Wd: 0.60 cm; H₁: 2.50 + x cm. Surface colour: 10R 5/6 red slip outside; 5YR 6/4 light reddish brown slip inside. Break: 5YR 6/4 light reddish brown. Decoration: painted; a very dark grey (10R 3/1) band outside on the rim (RPMO); horizontally painted bands inside, 1-5 mm wide, 10R 3/1 very dark grey and 10R 4/6 red (RPBI). Surface treatment: polished, low lustre.

No. 81: juglet (Fig. 58:9), Inv. No. P0028A (Drawing No. 0937)

RP	IV.TG 52	W ₂	---	ox.	3
----	----------	----------------	-----	-----	---

Neck fragment; swelling of the handle. Nd: 3.10 cm; Wd: 1.0 cm; H₃: 5.40 + x cm. Surface colour: 7.5YR 7/4 pink; 10R 5/6 red slip. Break: 5YR 6/6 reddish yellow. Technical details: applied handle. Surface treatment: polished, low lustre.

No. 82: juglet (Fig. 58:9), Inv. No. P2025A (Drawing No. 0458)

RP	≅ TD IV.21	W ₂	---	ox.	3
----	------------	----------------	-----	-----	---

Neck fragment and handle (broken). Nd: 2.90 cm; Wd: 0.40 cm; H₁: 5.24 + x cm. Surface colour: 10R 4/8 red slip. Break: 7.5YR 7/6 reddish yellow. Surface treatment: polished, low lustre.

No. 83: juglet (Fig. 58:9), Inv. No. P1063A (Drawing No. 0464)

BP	IV.TG 24	W ₂	---	ox.	3
----	----------	----------------	-----	-----	---

Neck fragment; collared neck. Nd: 2.90 cm; Wd: 0.47 cm; H₃: 6.40 + x cm. Surface colour: 7.5YR 5/4 brown slip. Break: 7.5YR 6/2 pinkish grey core; 7.5YR 6/6 reddish yellow oxidation zones. Technical details: throwing lines inside. Surface treatment: polished, low lustre.

Levantine household ware**No. 84: amphora, Inv. No. P1042A**

Uncoated	IV.TG 01	W ₂	---	med.	3
----------	----------	----------------	-----	------	---

Shoulder fragment; "torpedo" type. Md: 24.00 cm 7/64 on the shoulder; Wd: 0.50 cm; H₁: 3.40 + x cm. Surface colour: 7.5YR 7/6 reddish yellow. Break: 2.5YR 5/2 weak red core; 2.5YR 6/6 light red oxidation ones. Surface treatment: smoothed on the wheel.

No. 85: amphora (Fig. 58:9), Inv. No. P1091A (Drawing No. 0660)

Coated	IV.TG 01	W ₂	---	med.	3
--------	----------	----------------	-----	------	---

Shoulder fragment; "torpedo" type. Md: 30.00 cm 5/32; Wd: 0.50 cm; H₁: 3.20 + x cm. Surface colour: 2.5Y 8/3 pale yellow slip. Break: 2.5YR 5/2 weak red core; 2.5YR 6/6 light red oxidation zones. Surface treatment: smoothed on the wheel.

No. 86: amphora, IV.TG 03, body sherds: 0.20 dm².

No. 87: amphora, IV.TG 11, body sherds: 0.20 dm².

No. 88: amphora, IV.TG 18, 0.70 dm², body sherds.

No. 89: amphora, IV.TG 21, body sherds: 0.10 dm².

No. 90: amphora (Fig. 58:9), Inv. No. P2035A (Drawing No. 0661)

Uncoated	IV.TG 24	W ₂	---	med.	3
----------	----------	----------------	-----	------	---

Rim sherd; vertical direct rim. Rd: 14.00 cm 3/32; Wd: 1.10 cm; H₁: 2.30 + x cm. Surface colour: 5YR 7/6 reddish yellow. Break: 5YR 6/3 light reddish brown core; 5YR 7/8 reddish yellow oxidation zones. Surface treatment: smoothed on the wheel.

No. 91: amphora, IV.TG 24, body sherds: 0.10 dm².

No. 92: amphora (Fig. 58:10), Inv. No. P1088A (Drawing No. 0444)

Uncoated	IV.TG 51 (=TD IV.19)	W ₂	---	ox.	3
----------	----------------------	----------------	-----	-----	---

Shoulder fragment; "torpedo" type. Md: 22.00 cm 3/32; Wd: 0.70 cm; H₁: 5.50 + x cm. Surface colour: 2.5YR 7/6 light red self slip. Break: 2.5YR 7/6 light red. Technical details: throwing lines. Surface treatment: smoothed on the wheel. *Find No. 001.*

Phoenician fine ware*White Painted***No. 93: bowl (Fig. 58:10), Inv. No. P1044A (Drawing No. 0387)**

BPMO	IV.TG 38 = IV.Phoen.02	W ₂	---	ox.	3
------	------------------------	----------------	-----	-----	---

Rim and body sherd; slightly inverted direct rim. Rd: 15.00 cm 1/8; Wd: 0.30 cm; H₁: 5.10 + x cm. Surface colour: 10YR 7/3 very pale brown slip. Break: 2.5YR 6/8 light red. Decoration: horizontally painted lines inside and outside, 1-5 mm wide, 10YR 4/2 dark greyish brown. Surface treatment: polished, low lustre.

Cypriote fine ware*Brushed slip***No. 94: juglet (Fig. 58:10), Inv. No. P0024A (Drawing No. 0935)**

GBP	VI.TG 43	W ₂	---	ox.	3
-----	----------	----------------	-----	-----	---

Shoulder sherd. Md: 11.00 + x cm; Wd: 0.45 cm; H₁: 3.50 + x cm. Surface colour: 7.5YR 7/3-7/4 pink; brushed slip: 7.5YR 5/1 grey. Break: 10YR 7/1 light grey core; 7.5YR 6/6 reddish yellow oxidation zones. Technical details: very fine ridges inside. Decoration: three grooves on the shoulder. Surface treatment: polished, low lustre.

White Painted ware

No. 95: juglet (Fig. 58:10), Inv. No. P1221A (Drawing No. 0708)

BPMO	VI.TG 40	Ha ₂	---	ox.	3
------	----------	-----------------	-----	-----	---

Handle fragment; round section, single strap. Hd: 0.95 x 0.95 cm. Surface colour: 10YR 6/4 light yellowish brown slip. Break: 10YR 6/3 pale brown. Decoration: a black painted band? Surface treatment: polished, low lustre.

No. 96: jar (Fig. 58:10), Inv. No. P0228A (Drawing No. 0146)

BPMO	VI.TG 04	W ₂	---	ox.	3
------	----------	----------------	-----	-----	---

Body sherd. Md: ca 16.00 + x cm; Wd: 0.75 cm; H₁: 2.00 + x cm. Surface colour: 10YR 8/4 very pale brown slip. Break: 7.5YR 7/6 reddish brown. Decoration: horizontally painted bands, 10YR 2/2 very dark brown. Surface treatment: polished, low lustre.

No. 97: jug, Inv. No. P0755A

BPMO	VI.TG 40	W ₂	---	ox.	2-3
------	----------	----------------	-----	-----	-----

Two body sherds; barrel shape. Md: 18.00 + x cm; 16.00 + x cm. Surface colour: 10YR 8/4 very pale brown slip. Break: 7.5YR 7/6 reddish brown. Decoration: oblique painted lines 1 and 3 mm wide, 10YR 2/2 very dark brown. Surface treatment: polished; low lustre.

White Painted II ware

No. 98: bowl (Fig. 58:10), Inv. No. P0208A (Drawing No. 0202)

WPMO	VI.TG 04	W ₂	---	ox.	3
------	----------	----------------	-----	-----	---

Rim and body fragment; vertical direct rim, slightly everted. Rd: 20.00 cm 1/4; Wd: 0.65 cm; H₁: 7.30 + x cm. Surface colour: 2.5YR 8/3 pale yellow slip. Break: 5YR 5/6 yellowish red. Decoration: painted; a horizontally painted band on the rim, seven vertically lines, 2 mm wide, and two parallel cross lines outside; five horizontally lines, 2 mm and 1.4 mm wide, inside; colour: 10YR 3/2 very dark greyish brown. Surface treatment: polished, low lustre.

White Painted III ware

No. 99: juglet? (Fig. 58:11), Inv. No. P0776A (Drawing No. 0951)

WPMO	VI.TG 40	W ₂	---	ox.	3
------	----------	----------------	-----	-----	---

Body sherd. Md: 6.00 cm 1/8; Wd: 0.40 cm; H₁: 1.40 + x cm. Surface colour: 2.5Y 7/4 pale yellow slip. Break: 5Y 7/4 pale yellow. Decoration: three horizontally painted bands, 2 mm wide, 10YR 4/2 dark greyish brown. Surface treatment: polished, low lustre. *Find No. 008.*

White Painted V ware?

No. 100: bowl? (Fig. 58:11), Inv. No. P1040A (Drawing No. 0660)

WPMO	VI.TG 04	W ₂	---	ox.	3
------	----------	----------------	-----	-----	---

Rim and body fragment; everted direct rim. Rd: 15.00 cm 5/64; Wd: 0.90 cm; H₁: 2.30 + x cm. Surface colour: 2.5Y 7/3 pale yellow slip. Break: 5YR 8/4 pale yellow. Technical details: throwing lines inside. Decoration: five horizontally painted lines, 1-3 mm wide, 2.5Y 3/2 dark greyish brown. Surface treatment: polished, low lustre.

*White Painted V ware***No. 101: bowl (Fig. 58:11), Inv. No. P3000A** (before Inv. No. P0386A. Drawing No. 0311)

BPMO	VI.TG 40	W ₂	---	ox.	3
------	----------	----------------	-----	-----	---

Body sherd. Md: ca. 15.00 + x cm; Wd: 0.40 cm; H₁: 1.96 + x cm. Surface colour: 7.5YR 6/3 light brown slip. Break: 7.5YR 6/4 light brown. Decoration: horizontally painted lines inside, 1 mm wide, 7.5YR 2.5/2 very dark brown. Surface treatment: polished, low lustre.

*Black-on-Red ware***No. 102: juglet (Fig. 58:11), Inv. No. P0226A** (Drawing No. 0158)

RPMO	VI.TG 04	W ₂	---	ox.	3
------	----------	----------------	-----	-----	---

Body sherd. Md: ca. 6.00 + x cm; Wd: 0.30 cm; H₁: 2.00 + x cm. Surface colour: 10R 5/6 red slip. Break: 7.5YR 7/4 pink. Decoration: five horizontally painted lines, not well preserved, black colour. Surface treatment: polished, medium lustre.

No. 103: juglet (Fig. 58:11), Inv. No. P0367A (Drawing No. 0158)

BPMO	VI.TG 42	W ₂	---	ox.	3
------	----------	----------------	-----	-----	---

Body fragment. Md: 9.50 + x cm; Wd: 0.38 cm; H₁: 2.00 + x cm. Surface colour: 5YR 5/3 reddish brown slip. Break: 7.5YR 6/3 light brown core; a thick oxidation zone at exterior 7.5YR 5/3 brown. Decoration: two painted concentric circles on the shoulder and two horizontal bands, 2.5YR 3/1 reddish brown. Surface treatment: polished, medium lustre.

No. 104: juglet?, Inv. No. P2008A

RP [MO]	VI.TG 41	W ₂	---	ox.	3
---------	----------	----------------	-----	-----	---

Body sherd. Wd: 0.30 cm; H₁: 2.00 + x cm. Surface colour: 2.5YR 5/8 red slip. Break: 10R 6/8 light red. Decoration: ---. Surface treatment: polished.

No. 105: juglet (Fig. 58:11), Inv. No. P0375A (Drawing No. 0145)

WPMO	VI.TG 04	W ₂	---	ox.	2
------	----------	----------------	-----	-----	---

Body sherd. Md: ca. 15.00 cm; Wd: 0.50 cm; H₁: 1.95 + x cm. Surface colour: 5YR 7/6 reddish yellow slip. Break: 5YR 7/6 reddish yellow. Decoration: a painted band, 7 mm wide, 5YR 2.5/1 black. Surface treatment: polished, low lustre.

No. 106: juglet, Inv. No. P2009A

RP [MO]	≅ VI.TG 42	W ₂	---	ox.	3
---------	------------	----------------	-----	-----	---

Body sherd. Md: 7.00 cm 1/16; Wd: 0.30 cm; H₁: 2.80 + x cm. Surface colour: 2.5YR 4/6 red slip. Break: 2.5YR 7/6 light reddish brown inside and 2.5YR 6/6 light red outside. Decoration: ---. Surface treatment: polished, low lustre.

No. 107: jar (Fig. 58:11), Inv. No. P0374A (Drawing No. 0145)

RPMO	VI.TG 42	W ₂	---	ox.	2
------	----------	----------------	-----	-----	---

Body sherd. Md: ca. 15.00 cm; Wd: 0.45 cm; H₁: 5.50 + x cm. Surface colour: 2.5YR 6/6 red slip. Break: 7.5YR 6/4 light brown inside, 2.5YR 5/6 red outside. Technical details: throwing lines inside. Decoration: horizontally painted lines, 5 and 1 mm wide, 7.5YR 4/1 dark grey. Surface treatment: polished, low lustre.

*Cypriote household ware***No. 108: juglet (Fig. 58:12), Inv. No. P7098A** (Drawing No. 0937)

Uncoated	VI.TG 04	W ₂	---	ox.	3
----------	----------	----------------	-----	-----	---

Rim and neck fragment. Rd: 3.80 cm 3/4; Nd: 2.20 cm; Wd: 0.50 cm; H₃: 3.00 + x cm. Surface colour: 10YR 6/2 light brownish grey. Break: 7.5YR 6/3 light brown. Technical details: neck open with a stick. Surface treatment: eroded.

No. 109: amphora, VI.TG 40, body sherds: 0.10 dm².

No. 110: pilgrim flask? (Fig. 58:12), Inv. No. P7008A (Drawing No. 0902)

BS	VI.TG 42	W ₂ + Ha ₂	---	ox.	3
----	----------	----------------------------------	-----	-----	---

Neck and handles fragment. Nd: 1.70 cm; Wd: 0.35 cm; H₃: 3.60 + x cm; Hd: 1.70 x 0.55 cm. Surface colour: 7.5YR 6/4 light brown slip. Break: 2.5YR 4/8 red core; 7.5YR 5/4 brown oxidation zones. Technical details: handle from neck to [shoulder]; neck open with a stick. Surface treatment: smoothed.

No. 111: amphora, VI.TG 44, body sherds: 0.10 dm².

Aegean fine ware

No. 112: bowl (Fig. 58:12), Inv. No. P7104A (Drawing No. 0938)

RPMO	VII.TG 48 (Samian)	W ₂	---	ox.	3
------	--------------------	----------------	-----	-----	---

Body sherd. Md: ---; Wd: 0.35 cm; H₁: 2.20 + x cm. Surface colour: 7.5YR 6/6 reddish yellow; 10R 4/6 red slip. Break: 2.5YR 5/6 red. Decoration: four horizontally painted lines outside, 2.5YR 2.5/1 reddish black. Surface treatment: polished on both surfaces, high lustre.

No. 113: jar (Fig. 58:12), Inv. No. P0745A (Drawing No. 0461)

BP	VII.TG 48 (Samian)	W ₂	base finished on the wheel	ox.	3
----	--------------------	----------------	----------------------------	-----	---

Base fragment; ring base. Bd: 5.00 cm 7/32; Wd: 0.45 cm; H₁: 1.00 + x cm. Surface colour: 5YR 5/4 reddish brown slip. Break: 5YR 6/6 reddish yellow. Surface treatment: polished, medium lustre.

Black-on-Red ware

No. 114: juglet (Fig. 58:12), Inv. No. P0368A (Drawing No. 0145)

BPMO	VII.TG 39	W ₂	---	ox.	3
------	-----------	----------------	-----	-----	---

Rim and neck fragment; everted direct rim. Rd: 3.00 cm 1/4; Nd: 1.75 cm; Wd: 0.30 cm; H₃: 0.80 + x cm. Surface colour: 5YR 6/4 light reddish brown slip. Break: 2.5YR 6/6 red. Decoration: a painted band on the rim, inside and outside, 2.5YR 3/1 reddish brown. Surface treatment: polished, low lustre. Smoked.

No. 115: juglet (Fig. 58:12), Inv. No. P0376A (Drawing No. 0143)

RPMO	VII.TG 39	W ₂	---	ox.	3
------	-----------	----------------	-----	-----	---

Rim and neck fragment; everted direct rim. Rd: 3.00 cm 7/32; Wd: 0.30 cm; H₃: 1.20 + x cm. Surface colour: 2.5YR 6/6 red slip. Break: 2.5YR 6/4 weak red. Decoration: a painted band on the rim inside and outside?, colour: 2.5YR 4/1 dark reddish grey. Surface treatment: polished, low lustre.

No. 116: juglet (Fig. 58:12), Inv. No. P0377A (Drawing No. 0144)

RPMO	VII.TG 39	W ₂	---	ox.	3
------	-----------	----------------	-----	-----	---

Rim and neck fragment; everted direct rim. Rd: 4.00 cm 3/16; Wd: 0.35 cm; H₃: 1.16 + x cm. Surface colour: 2.5YR 4/4 dusky red. Break: 5YR 6/4 light reddish brown. Decoration: a painted band on the rim inside and outside, 2.5YR 2.5/1 reddish black. Surface treatment: polished, low lustre. Smoked.

No. 117: juglet (Fig. 58:12), Inv. No. P0771A (Drawing No. 0461)

BPMO	VII.TG 39	W ₂	---	ox.	3
------	-----------	----------------	-----	-----	---

Body sherd; globular type. Md: ca. 8.00 cm; Wd: 0.35 cm; H₁: 2.40 + x cm. Surface colour: 5YR 4/3 reddish brown slip. Break: 5YR 5/4 reddish brown. Decoration: two

painted circles, 5YR 3/2 dark reddish brown. Surface treatment: polished, high lustre. *Find No. 008.*

No. 118: juglet (Fig. 58:12), Inv. No. P0775A (Drawing No. 0391)

RPMO	VII.TG 39	W ₂	---	ox.	3
------	-----------	----------------	-----	-----	---

Body sherd. Md: ca. 8.00 cm; Wd: 0.35 cm; H₁: 3.50 + x cm. Surface colour: 5YR 5/6 yellowish red slip. Break: 5YR 6/6 reddish yellow. Technical details: throwing lines inside. Decoration: three horizontally painted lines, 1 mm wide, 5YR 3/1 very dark grey. Surface treatment: polished, high lustre. *Find No. 008.*

No. 119: juglet (Fig. 58:12), Inv. No. P1097A (Drawing No. 0435)

RPMO	VII.TG 39	W ₂	---	ox.	3
------	-----------	----------------	-----	-----	---

Rim and neck fragment; everted direct rim. Rd: 3.60 cm; Nd: 1.20 cm; Wd: 0.20 cm; H₃: 1.83 + x cm. Surface colour: 2.5YR 6/6 light red slip. Break: 2.5YR 6/8 light red. Technical details: rilling lines inside. Decoration: painted lines, 4-6 mm wide, 2.5YR 4/2 weak red. Surface treatment: polished, low lustre.

No. 120: juglet (Fig. 58:12), Inv. No. P1179A (Drawing No. 0702)

RPMO	VII.TG 39	W ₂	---	ox.	3
------	-----------	----------------	-----	-----	---

Neck fragment; collared neck. Nd: 1.60-2.00 cm; Wd: 0.40 cm; H₃: 2.70 + x cm. Surface colour: 2.5YR 5/6 red slip. Break: 2.5YR 6/6 light red. Technical details: neck open with a stick. Decoration: ----. Surface treatment: polished, low lustre.

No. 121: juglet (Fig. 58:12), Inv. No. P0354A (Drawing No. 0146)

RPMO	VII.TG 39	W ₂	---	ox.	3
------	-----------	----------------	-----	-----	---

Body sherd. Md: ca. 13.00 + x cm; Wd: 0.25 cm; H₁: 1.10 + x cm. Surface colour: 10R 5/8 red slip. Break: 10R 6/8 light red. Technical details: throwing lines inside. Decoration: horizontally painted bands, 2 mm wide, 2.5YR 3/3 dark reddish brown. Surface treatment: polished, high lustre.

No. 121bis: juglet (Fig. 58:13), Inv. No. P1051A (Drawing No. 0928)

RPMO	VII.TG 39	W ₂	---	ox.	3
------	-----------	----------------	-----	-----	---

Body sherd. Wd: 0.30 cm; H₁: 1.50 + x cm. Surface colour: 10R 4/6 red slip. Break: 2.5YR 5/8 red. Decoration: ---. Surface treatment: polished, medium lustre.

No. 122: juglet (Fig. 58:13), Inv. No. P1041A (Drawing No. 0660)

RPMO	VII.TG 39	W ₂	---	ox.	3
------	-----------	----------------	-----	-----	---

Rim and neck sherd; everted direct rim; pinched rim. Rd: ca. 4.05 cm 1/16; Wd: 0.30 cm; H₁: 2.90 + x cm. Surface colour: 2.5YR 5/8 red slip. Break: 5YR 7/6 reddish yellow. Decoration: two painted lines on the body, 2 mm wide, and one on the rim, outside, 2.5YR 3/2 dusky red. Surface treatment: polished, low lustre.

No. 123: juglet (Fig. 58:13), Inv. No. P0773A (Drawing No. 0387)

RPMO	VII.TG 39	W ₂	---	ox.	3
------	-----------	----------------	-----	-----	---

Body sherd. Md: 7.80 cm 1/8; Wd: 0.40 cm; H₁: 3.30 + x cm. Surface colour: 2.5YR 4/6 red slip. Break: 5YR 6/6 reddish yellow. Decoration: six horizontally painted lines, 1 mm wide, and four circular, 2.5YR 3/3 dark reddish brown. Surface treatment: polished, high lustre. *Find No. 008.*

No. 124: jug (Fig. 58:13), Inv. No. P1093A (Drawing No. 0435)

RPMO	VII.TG 39 c.	W ₂	---	ox.	3
------	--------------	----------------	-----	-----	---

Wall fragment; barrel shape. Wd: 0.50 cm; H_1 : 3.20 + x cm. Surface colour: 2.5Y 6/8 light red slip. Break: 7.5YR 6/3 light brown core; 2.5YR 6/6 light red oxidation zones. Decoration: circular painted lines, 1.5 mm and 7 mm wide, 2.5YR 4/2 weak red. Surface treatment: polished, medium lustre.

No. 125: juglet (Fig. 58:13), Inv. No. P0216A (Drawing No. 0118)

RPMO	VII.TG 39	Ha ₂	---	ox.	3
------	-----------	-----------------	-----	-----	---

Handle fragment; oval in section; 1; single strap. Hd: 1.10 x 0.80 cm. Surface colour: 2.5YR 6/8 red slip. Break: 5YR 6/6 reddish yellow. Decoration: two horizontally painted bands along the handle and a vertically one on the handle base, 5 mm wide, 2.5 4/3 dusky red. Surface treatment: polished, medium lustre.

No. 126: juglet (Fig. 58:13), Inv. No. P0219A (Drawing No. 0302)

WP[MO]	VII.TG 39	Ha ₂	---	ox.	3
--------	-----------	-----------------	-----	-----	---

Handle fragment; nearly round in section; 1; single strap. Hd: 0.70 x 0.80 cm. Surface colour: 5YR 7/6 reddish yellow and 7/4 pink slip. Break: 5YR 7/4 pink. Decoration: ----. Surface treatment: polished, low lustre.

No. 127: juglet (Fig. 58:13), Inv. No. P0362B (Drawing No. 0142)

BPMO	VII.TG 45	W ₂	----	ox.	3
------	-----------	----------------	------	-----	---

Rim, neck, handle and part of the body; compound neck; everted direct rim. Rd: 3.00 cm 3/4; Nd: 1.40-1.70 cm; Md: 5.00 + x cm?; Wd: 0.35 cm; H_1 : 4.80 + x cm; Hd: 0.70 x 0.60 cm. Surface colour: 10YR 4/4 dark yellowish brown slip. Break: 10YR 4/4 dark yellowish brown. Technical details: throwing lines inside. Decoration: horizontally painted bands on the rim, neck and shoulder, and on the handle, 2.5YR 3/6 dark red. Surface treatment: polished, low lustre. Observations: in the Abu Seifa exhibition room. *Find No. 018*.

No. 128: juglet (Fig. 58:13), Inv. No. P0366A (Drawing No. 0145)

RPMO	VII.TG 45	W ₂	---	ox.	3
------	-----------	----------------	-----	-----	---

Body sherd. Md: ca. 12.00 cm; Wd: 0.30 cm; H_1 : 1.70 + x cm. Surface colour: 2.5YR 5/6 red slip. Break: 7.5YR 6/3 light brown core; 2.5YR 6/6 red oxidation zones. Decoration: five horizontally painted lines, 1 mm wide, 2.5YR 2.5/1 reddish black. Surface treatment: polished, high lustre.

No. 129: juglet (Fig. 58:14), Inv. No. P0772A (Drawing No. 0391)

RPMO	VII.TG 45	W ₂	---	ox.	3
------	-----------	----------------	-----	-----	---

Body sherd. Md: ca. 6.00 + x cm; Wd: 0.32 cm; H_1 : 1.30 + x cm. Surface colour: 2.5YR 4/8 red slip. Break: 10R 5/6 red. Technical details: throwing lines inside. Decoration: horizontally painted lines, 1 mm wide, 2.5YR 3/2 dusky red. Surface treatment: polished, high lustre. *Find No. 008*.

No. 130: juglet, Inv. No. P1038A

RP[MO]	VII.TG 45	W ₂	---	ox.	3
--------	-----------	----------------	-----	-----	---

Neck sherd. Nd: 4.00 cm 5/32; Wd: 0.30 cm; H_3 : 2.60 + x cm. Surface colour: 2.5YR 5/8 red slip. Break: 2.5YR 6/6 light red. Decoration: ----. Surface treatment: polished, medium lustre.

No. 131: juglet (Fig. 58:14), Inv. No. P1046A (Drawing No. 0388)

RPMO	VII.TG 45	W ₂	---	ox.	3
------	-----------	----------------	-----	-----	---

Neck and shoulder fragment. Nd: ca. 4.00 cm; Wd: 0.40 cm; H_1 : 1.60 + x cm. Surface colour: 10R 5/6 red slip. Break: 10R 5/8 red. Technical details: throwing lines inside.

Decoration: a painted line, 3 mm wide, 7.5YR 3/2 dark brown. Surface treatment: polished, low lustre.

Black-on-Red I ware

No. 132: juglet (Fig. 58:14), Inv. No. P1185A (Drawing No. 0623)

RPMO	VII.TG 39	W ₂	---	ox.	3
------	-----------	----------------	-----	-----	---

Neck fragment and swelling of the handle; collared neck. Nd: 1.00 cm; Wd: 0.30 cm; H₃: 2.50 + x cm. Surface colour: 2.5YR 5/6 red slip. Break: 2.5YR 6/3 light reddish brown. Decoration: ----. Surface treatment: polished, low lustre.

No. 133: juglet (Fig. 58:14), Inv. No. P2012A (Drawing No. 0447)

RPMO	VII.TG 39	W ₂	---	ox.	3
------	-----------	----------------	-----	-----	---

Body sherd. Md: ca. 5.50 cm; Wd: 0.20 cm; H₁: 2.60 + x cm. Surface colour: 5YR 5/6 red slip. Break: 2.5YR 6/6 light red. Technical details: throwing lines inside. Decoration: two horizontally painted lines, 1mm wide, 2.5YR 2.5/1 reddish black. Surface treatment: polished, high lustre.

Black-on-Red II ware

No. 134: juglet (Fig. 58:14), Inv. No. P0127A (Drawing No. 0168/928)A

RPMO	VII.TG 45	W ₂	W	ox.	3
------	-----------	----------------	---	-----	---

Base fragment; flat base. Bd: 4.00 cm 1/4; Wd: 0.30 cm; H₁: 1.50 + x cm. Surface colour: 10R 5/6 red slip. Break: 2.5YR 6/6 light red. Technical details: throwing lines inside. Decoration: painted, 2.5YR 2.5/1 reddish black. Surface treatment: polished, high lustre.

No. 135: juglet (Fig. 58:14), Inv. No. P0023A (Drawing No. 0391) .

WPMO	VII.TG 39	W ₂	---	ox.	3
------	-----------	----------------	-----	-----	---

Body sherd. Md: 7.00 cm; Wd: 0.35 cm; H₁: 2.80 + x cm. Surface colour: 5YR 6/6 reddish yellow slip. Break: 7.5YR 7/3 pink. Decoration: two painted concentric circles, 10R 3/2 dusky red. Surface treatment: polished, high lustre.

Black-on-Red IV ware

No. 136: juglet (Fig. 58:14), Inv. No. P0210A₁₋₂ (Drawing No. 0120)

BPMO	VII.TG 39	W ₂	----	ox.	3
------	-----------	----------------	------	-----	---

Neck fragment, and body fragment; compound neck. Nd: 1.30-1.80 cm; Md: 8.00 cm; Wd: 0.25 cm; H₁: 2.00 + x cm; H₃: 2.60 + x cm. Surface colour: 2.5YR 5/4 reddish brown slip. Break: 2.5 YR 6/4 light reddish brown. Decoration: painted lines, 2 mm and 4 mm wide, 2.5 YR 2.5/1 reddish black. Surface treatment: polished, low lustre.

No. 137: juglet (Fig. 58:14), Inv. No. P2028A (Drawing No. 0452)

BPMO	VII.TG 45	W ₂	---	med.	3-4
------	-----------	----------------	-----	------	-----

Body sherd. Md: 10.00 cm 5/32; Wd: 0.30 cm; H₁: 1.90 + x cm. Surface colour: 5YR 4/4 reddish brown slip. Break: 5YR 6/6 reddish yellow. Technical details: throwing lines inside. Decoration: horizontally painted lines and a circle, 2.5YR 2.5/1 reddish black. Surface treatment: polished, high lustre.

Bichrome ware

No. 138: juglet, Inv. No. P2022A (Drawing No. 0454)

RPBI	VII.TG 39	W ₂	---	---	3
------	-----------	----------------	-----	-----	---

Body sherd. Md: 9.00 cm 7/32; Wd: 0.20 cm; H₁: 2.60 + x cm. Surface colour: 2.5YR 6/1 reddish grey slip. Break: 5YR 6/2 pinkish grey. Technical details: throwing lines inside. Decoration: two painted bands, 6 mm wide, 10R 3/1 very dark grey and 10R 3/6 dark red.

Surface treatment: polished, low lustre. Smoked.

No. 139: juglet (Fig. 58:14), Inv. No. P0211A (Drawing No. 0119)

WPBI	VII.TG 39	W ₂	---	ox.	3
------	-----------	----------------	-----	-----	---

Neck fragment; compound neck. Nd: 2.70 cm 1/2; Wd: 0.40 cm; H₃: 4.00 + x cm. Surface colour: 10YR 8/6 yellow slip. Break: 10YR 8/6 yellow. Technical details: throwing lines inside. Decoration: horizontally painted lines, 1 and 10 mm wide, 10R 6/8 light red and 10R 3/1 very dark grey. Surface treatment: polished.

No. 140: jug? (Fig. 58:15), Inv. No. P0365A (Drawing No. 0145)

WPBI	VII.TG 48 (Samian)	W ₂	---	ox.	3
------	--------------------	----------------	-----	-----	---

Body sherd. Md: ca. 15.00 cm; Wd: 0.45 cm; H₁: 2.55 + x cm. Surface colour: 5YR 7/6 reddish yellow. Break: 5YR 7/6 reddish yellow. Decoration: horizontally painted bands, 5YR 2.5/1 black and 10R 4/4 weak red. Surface treatment: polished, low lustre.

Aegean household ware

Plain White

No. 141: bowl (Fig. 58:15), Inv. No. P1066A (Drawing No. 0660)

WS	VII.TG 39	W ₂	---	med.	3
----	-----------	----------------	-----	------	---

Rim sherd; everted direct rim. Rd: 12.00 cm; Wd: 0.30 cm; H₁: 1.90 + x cm. Surface colour: 7.5YR 8/3 pink slip. Break: 2.5YR 7/8 light red inside, 7.5YR 6/6 reddish yellow outside. Surface treatment: smoothed on the wheel.

II.- Finds

No. 142: scaraboid seal (Plate 8), Inv. No. F0166 (Drawing No. 0094). Fragmentary; steatite. 1.50 cm x 1.30 cm x 0.70 cm. Description: porcupine-shaped carved back; oval base with incised decoration: a *hs* jar flanked by two *w3dyt* figures (with the red crown preserved on the right one) and the *r^c* (?) hieroglyphic sign over the *hs* jar; longitudinal perforation. Observations: broken on both sides, near the holes of perforation. SCA No.1010.

No. 143: statuette? (Plate 9), Inv. No. F0189A (Drawing No. 0105. F29). Fragmentary; diorite. 4.50-3.30 x 4.00 x 1.30 cm.

No. 144: statuette (base), Inv. No. F0266A. Fragmentary; faience; moulded. Size: 1.90 x 1.40 x 0.70 cm; colour: Chart 2 for glay 8/2 (light greenish grey). Description: only the feet of a figure, human or animal, are preserved.

No. 145: royal (?) torso (Plate 10), Inv. No. F0280. Fragmentary; faience; moulded. 2.41 cm x 1.60 cm x 1.22 cm; colour: 10 YR 8/4 very pale brown. Description: a human torso holding the *w3s* scepter in the left hand. Almost illegible. A royal name (?), *3-ib-r^c* (?), is inscribed on the back. SCA No.1032.

Amulets

No. 146: baboon-shaped pendant? (Fig. 58:15), Inv. No. F0096A (Drawing No. 0468). Fragmentary; faience; moulded. 0.90 x 0.60 x 0.50 cm; colour: Chart 1 for gley 7/56 light greenish grey. Baboon seated on a base; a pillar at the back; perforation: 1 mm. Broken. *Find No. 007*.

No. 147: heart amulet, Inv. No. F0264A. Faience; moulded. 2.00 x 2.00 x 1.20 cm; colour: 10YR 7/2 light grey. *Find No. 002*.

Wdjat amulets

No. 148: wdjat (Plate 11), Inv. No. F0013A (Drawing No. 0173). Fragmentary; faience; moulded. 2.90 cm x 1.30-2.10 cm x 0.30 cm; colour: 5G 7/2 pale green; lines: 10R 6/1

light grey - 6/2 pale red (obverse), 10Y 7/1 light greenish grey (reverse). Description: right Wdjat; decorated with incised lines. Observations: good quality faience; a preserved glazing layer. *Find No. 20.*

No. 149: wdjat (Plate 12), Inv. No. F0165A (Drawing No. 0099. F28). Fragmentary; faience; moulded. 0.11 x 0.11 x 0.30 cm; colour: 10GY 7/1 (light greenish grey).

No. 150: wdjat?, Inv. No. F0271A. Fragmentary; faience; moulded. 1.40 x 1.00 x 0.40 cm; colour: 10YR 8/1 (white). Almost of rectangular shape, with an edge at the top; remains of greenish glaze. *Find No. 005.*

Personal objects

No. 151: bead, Inv. No. F0022. Fragmentary; chert? 0.80 x 1.10 cm; colour: 7.5YR 3/1 very dark grey; spherical shape; partially eroded. SCA No.1035. *Find No. 001.*

No. 152: bead (Fig. 58:15), Inv. No. F0270 (Drawing No. 0502). Complete; alabaster? 0.50 x 0.50 cm; cylindrical shape; perforation: 1-2 mm. SCA No.1035. *Find No. 004.*

No. 153: ring? (Fig. 58:15), Inv. No. F0090A (Drawing No. 0173). Complete; bronze; melted. 2.70 x 2.70 x 0.40 cm.

Faience

No. 154: bead, Inv. No. F0061A. Fragmentary; faience. 0.30 x 0.10 x 0.10 cm; colour white; cylindrical shape; destroyed.

No. 155: beads (10), Inv. No. F0163 (Drawing No. 0468). Fragmentary; faience; moulded. D: 0.30-0.70 cm; colour Chart 1 for gley 5GY 6/1 greenish grey. Spherical shape. SCA No. 4020.

No. 156: bead, Inv. No. F0232A (Drawing No. 0148). Fragmentary; faience; moulded. 1.00 x 0.40 x 0.30 cm; colour: 10R 3/5 dusky red; spherical shape.

No. 157: bead (Fig. 58:15), Inv. No. F0248A (Drawing No. 0501). Complete; faience; moulded. 1.30 x 0.40 cm; colour: Chart 1 for glay 7/1 light greenish grey and 10YR 8/1 white; cylindrical shape; perforation: 1 mm. *Find No. 001.*

No. 158: bead (Fig. 58:16), Inv. No. F0269A (Drawing No. 0502). Complete; faience; moulded. 0.70 x 0.50 cm; colour: 10YR 4/3 brown; cylindrical shape; perforation: 3 mm. *Find No. 003.*

No. 159: bead, Inv. No. F0269A (Drawing No. 0502). Complete; faience. 0.26 x 0.10 cm; colour: 10YR 5/2 greyish brown; cylindrical shape; perforation: 1 mm.

No. 160: bead, Inv. No. F0257A. Fragmentary; faience; moulded. 0.70 x 1.80 cm; colour: white. Cylindrical shape. *Find No. 008.*

No. 161: bead (Fig. 58:16), Inv. No. F0922A. Complete, shell (*Ciprea albina*), 1.40 x 1.10 cm x 0.030 cm. Function: female fertility amulet.

Tools

No. 162: sharpener, Inv. No. F0334A. Fragmentary; pumice. 4.40 x 3.60-2.80 x 2.80 cm.

No. 163: fish hook (Fig. 58:16), Inv. No. F0928A (Drawing No. 0939). Fragmentary; bronze; melted. 2.00 x 0.20 cm; cylindrical section; the curve part of the hook is lacking.

No. 164: polisher (Fig. 58:16), Inv. No. F1096A (before Inv. No. F0933B. Drawing No. 0924). Fragmentary; material: ?; colour: black. Primary form: half pebble. 1.40 x 0.80 cm. Degree of ware: 1-Light. Wear marks: light striations. Stroke: combination.

Suspended weights

No. 165: net weight (Fig. 58:16), Inv. No. F0758A (Drawing No. 0622). Fragmentary; lead; melted. 1.10 x 0.40 x 2.00 cm; U-shape. Function: fishing.

No. 166: net weight, Inv. No. F0958A. Fragmentary; limestone. 6.50 cm length; it is broken along the axial perforation. Function: fishing.

No. 167: loom weight (Fig. 58:16), Inv. No. F1006A (Drawing No. 0946). Fragmentary; clay; hand-made. 12.00 x 5.50 cm; colour: 7.5YR 5/4 brown; perforation: 9 mm.

Grinding stone

No. 168: netherstone (Fig. 58:16), Inv. No. F0109A (Drawing No. 0284/1013). Composed; double; complete; sandstone. Weight: 1,008.00 gr. 15.00 x 11.20 x 6.10 cm. Used surface: 7.90 x 6.90 cm. Primary form: cobble. Manufacture technique: ground to shape, Characteristics: slightly modified. Colour: pinkish white. Comments: perhaps broken. Degree of wear: 2-Medium. Wear type: abrasion and percussion. Wear marks: striations. Surfaces: 2. Contact: opposite. Surface configuration: flat. Stroke: perpendicular. *Find No. 005.*

Objects of unknown use

Faience

No. 169: fragment of an object, Inv. No. F0039A. Faience; 1.50 x 1.50 x 0.80 cm.

No. 170: fragment of an object, Inv. No. F0784A. Faience; 2.00 x 2.00 x 1.20 cm.

No. 171: fragment of an object, Inv. No. F1067A. Faience.

Bronze

No. 172: fragment of an object, Inv. No. F0016A. Bronze. 1.20 x 1.00 x 0.30 cm.

No. 173: fragment of an object, Inv. No. F0112A. Bronze. 0.92 x 0.97 x 0.39 cm; conical shape. *Find No. 001.*

No. 174: fragment of an object, Inv. No. F0202A. Bronze.

No. 175: fragment of an object (Fig. 58:17), Inv. No. F0231A (Drawing No. 0181). Fragmentary; iron; melted. 2.90 x 1.10 x 1.20 cm. Part of a blade?

No. 176: fragment of an object, Inv. No. F0237A. Bronze. 1.06 x 1.00 x 0.67 cm. *Find No. 002.*

No. 177: fragment of an object, Inv. No. F0246A. Bronze. 0.20 x 1.10 x 0.94 cm; conical shape.

No. 178: fragment of an object, Inv. No. F0249A. Bronze. 2.00 x 0.65 cm.

No. 179: fragments (3) of an object (Fig. 58:17), Inv. No. F0553A (Drawing No. 0640). Bronze; melted. 1) 0.40 x 0.20 x 0.20 cm; 2) 1.20 x 0.20 x 0.20 cm; 3) 2.00 x 0.30 x 0.20 cm. Part of a needle?

No. 180: fragment of an object, Inv. No. F0723A (Drawing No. 0640). Bronze; melted. 3.80 x 1.40 x 0.80 cm.

No. 181: fragment of an object, Inv. No. F1049A. Bronze.

Limestone

No. 182: fragment of an object, Inv. No. F0012A (Drawing No. 0183). Limestone. 1.80 x 1.40 x 0.70 cm; fragment of a loom weight?

No. 183: fragment of an object, Inv. No. F0030A. Limestone. 6.40 x 4.60 x 2.00 cm.

No. 184: fragment of an object, Inv. No. F0088A. Limestone. 6.40 x 4.60 x 2.00 cm.

No. 185: fragment of an object, Inv. No. F1066A. Limestone.

Raw material

No. 186: bitumen, Inv. No. F0729A.

Product

No. 187: faience slag, Inv. No. F0333A.

No. 188: faience slag, Inv. No. F0730A.

No. 189: faience slag, Inv. No. F0777A

No. 190: faience slag, Inv. No. F0785A.

No. 191: faience slag, Inv. No. F0792A.

No. 192: faience slag, Inv. No. F0793A.

No. 193: faience slag, Inv. No. F0802A.

No. 194: faience slag, Inv. No. F0809A.

No. 195: faience slag, Inv. No. F1053A.

No. 196: metal slag, Inv. No. F1029A.

No. 197: pieces (2) of glass?, Inv. No. F0017A (Drawing No. 0183). Complete; glass (transparent). 1) 2.00 x 0.50 x 0.50 cm; 2) 1.90 x 0.50 x 0.50 cm. Prismatic shape, rectangular base.

No. 198: a glass object (Fig. 58:17), Inv. No. F0224 (Drawing No. 0114. F30). Complete; glass. 1.00 x 0.30 cm; blue; semi-spheric; the stone of a ring? SCA No.1026.

No. 199: core (Fig. 58:17), Inv. No. F0957A (Drawing No. 0942). Complete; chert; colour: very pale brown. Weight: 170.00 gr. 6.40 x 4.50 x 5.00 cm. Primary form: pebble. Manufacture technique: flaking. Characteristics: one complete flake detached.

List of Figures and Plates (Area II) by Loci

AREA II		
LOCUS	FIGURE	PLATE
L1001 = L1004	Fig. 58	Plates 8-12
L1008	Fig. 38	
L1010	Fig. 39	
L1014	Fig. 40	
L1016	Fig. 41	
L1024	Fig. 43	
L1025	Fig. 44	
L1031	Fig. 42	
L1038	Fig. 45	
L1039	Fig. 46	
L1043	Fig. 47	Plate 2
L1054	Fig. 48	Plate 3
L1058	Fig. 51	Plates 4-6
L1060	Fig. 49	
L1061	Fig. 50	
L1065	Fig. 52	
L1069	Fig. 53	
L1084	Fig. 54	
L1090	Fig. 55	
L1091		Plate 7
L1094	Fig. 56	
L1095	Fig. 57	
L1102	Fig. 11	
L1104	Fig. 12	
L1107	Fig. 13	
L1112 = L1102bis	Fig. 14	
L1122	Fig. 15	
L1123	Fig. 16	
L1124	Fig. 17	
L1125	Fig. 18	
L1126	Fig. 19	
L1138	Fig. 37	
L1212	Fig. 33	
L1214	Fig. 34	
L1217	Fig. 20	
L1219	Fig. 35	
L1221	Fig. 36	
L1224	Fig. 21	
L1225	Fig. 22	Plate 1
L1228 = L1237	Fig. 23	
L1229	Fig. 24	
L1230	Fig. 25	
L1231	Fig. 01	
L1233	Fig. 02	
L1234	Fig. 03	
L1235	Fig. 04	
L1236	Fig. 26	

LOCUS	FIGURE	PLATE
L1400	Fig. 27	
L1404	Fig. 28	
L1406	Fig. 29	
L1407	Fig. 30	
L1408	Fig. 05	
L1409	Fig. 06	
L1410	Fig. 07	
L1413	Fig. 08	
L1417	Fig. 31	
L1419	Fig. 09	
L1420	Fig. 10	
L1423	Fig. 32	

List of Figures and Plates (Area II)

AREA II		
FIGURE	PLATE	LOCUS
Fig. 01		L1231
Fig. 02		L1233
Fig. 03		L1234
Fig. 04		L1235
Fig. 05		L1408
Fig. 06		L1409
Fig. 07		L1410
Fig. 08		L1413
Fig. 09		L1419
Fig. 10		L1420
Fig. 11		L1102
Fig. 12		L1104
Fig. 13		L1107
Fig. 14		L1112 = L1102bis
Fig. 15		L1122
Fig. 16		L1123
Fig. 17		L1124
Fig. 18		L1125
Fig. 19		L1126
Fig. 20		L1217
Fig. 21		L1224
Fig. 22	Plate 1	L1225
Fig. 23		L1228 = L1237
Fig. 24		L1229
Fig. 25		L1230
Fig. 26		L1236
Fig. 27		L1400
Fig. 28		L1404
Fig. 29		L1406
Fig. 30		L1407
Fig. 31		L1417
Fig. 32		L1423
Fig. 33		L1212
Fig. 34		L1214
Fig. 35		L1219
Fig. 36		L1221
Fig. 37		L1138
Fig. 38		L1008
Fig. 39		L1010
Fig. 40		L1014
Fig. 41		L1016
Fig. 42		L1031
Fig. 43		L1024
Fig. 44		L1025
Fig. 45		L1038
Fig. 46		L1039
Fig. 47	Plate 2	L1043
Fig. 48	Plate 3	L1054

FIGURE	PLATE	LOCUS
Fig. 49		L1060
Fig. 50		L1061
Fig. 51	Plates 4-6	L1058
Fig. 52		L1065
Fig. 53		L1069
Fig. 54		L1084
Fig. 55		L1090
	Plate 7	L1091
Fig. 56		L1094
Fig. 57		L1095
Fig. 58	Plates 8-12	L1001 = L1004

PART III: AREA VI

Abstract: Geophysical surveying conducted in 1998 by Jorge Trench³⁴ detected, among other features, what seemed to be a building in AZ/56 and neighbouring squares (Plan X). A small test pit confirmed the existence of a mud brick wall. This part of the site was identified as Area VI and in the next season (1999), open area excavation was performed. Eventually, 19 squares (475 m²) were opened, from AX/54 in SW to BA57 in NE.

The sequence in Area VI (Plan I) can be divided in three levels: I. - Pre-Building F; II.- Building F (Plan VIII); III.- Post-Building F. A brief description of the stratigraphy and features follows, from the earliest levels to the surface (Graphic VII).

LEVEL I: Pre-Building F

1.- Stratigraphic sequence

Locus	Description	Interpretation, comments
L0550 and L0591	Aeolian sand, clean and archaeologically sterile with the exception of a few sherds and bones, which are considered to be intrusive. Some bioturbation was noted. L0591 was reached in a test pit excavated in Square AZ/55.	Pre-occupational sediment.
L0549	Sandy clay. Its upper part, which contacts L0548, features charcoal in lenses or as dispersed particles, along with ashes. Its lower part merges with basal sand L0591.	Human frequentation.
L0589	Compact sediment, rich in clay and in trodden charcoal remains. In Squares AY/54 and AZ/54, two hearths are associated to this occupational surface. It was cut by ditches L0588 and L0590.	Floor.
L0548	Sandy clay with ash and shallow charcoal lenses, perhaps dispersed by human frequentation. The charcoals are very fragile.	Human frequentation.
L0518	Dark, sandy sediment with charcoals.	Human frequentation.
L0547	Sand with some clay and small charcoals.	Human frequentation
L0590	Several ditches meeting at right angles which cut into L0589.	Foundation trenches of flimsy structures. The floors seem to have been deflated.
L0587	Sand, covering in unconformity the ditches L0590.	An Aeolian deposit following a deflationary episode.
L0588	Ditches meeting at right angles. They were excavated from L0511 and reached L0589.	Foundation trenches of light structure(s) structures.
L0511	Very sandy clay with charcoal particles.	An occupational surface.

³⁴ See: Jorge Trench, "The Geophysical Survey of the Site. Methodology and Results", in *Tell el-Ghaba II, Studies* (forthcoming).

Locus	Description	Interpretation, comments
L0511	From this locus, the ditches L0588 were dug.	
L0517	Clean sand, very poor in archaeological remains. A later fire, which affected Room L0515 of Building F, oxidised its upper part.	A natural deposit.
L0546	Yellow very sandy clay. Few archaeological remains.	Natural fill.

2.- Archaeological material

L0511 (Fig. 1)

I.- Pottery

a) Egyptian pottery

Nile silt clay

Egyptian fine ware

No. 1: juglet, Inv. No. C-6001 [015]

RP	Nile B ₂	W ₂
----	---------------------	----------------

Body sherd; Md: 10.00 cm; throwing lines inside; red slipped polished.

No. 2: juglet, Inv. No. C-6001 [035]

RP	Nile B ₂	W ₂
----	---------------------	----------------

Body sherd; Md: ca. 15.00 cm; throwing lines inside; red slipped polished.

Egyptian household ware

No. 3: bowl (Fig. 1:1), Inv. No. C-6001 [013]

Uncoated	Nile B ₂	W ₂
----------	---------------------	----------------

Rim sherd; carinated bowl, everted direct rim. Rd: 20.00 cm 1/8; Wd: 0.70 cm; H₁: 3.50 + x cm; throwing lines outside and inside; made in parts, smoothed on the wheel.

No. 4: bowl, Inv. No. C-6001 [051]

Uncoated	Nile C ₂	W ₂
----------	---------------------	----------------

Rim sherd; ledge rim. Rd: 35.00 cm 1/8; throwing lines outside and inside; smoothed on the wheel; eroded.

No. 5: deep bowl (Fig. 1:1), Inv. No. C-6001 [019]

Uncoated	Nile B ₂	W ₂
----------	---------------------	----------------

Rim sherd; everted direct rim. Rd: 12.00 cm 1/16; Wd: 0.30 cm; H₁: 3.00 + x cm; throwing lines outside and inside; a groove below the rim; smoothed on the wheel. Another, Rd 12.00 cm 1/16.

No. 6: cooking pot (Fig. 1:1), Inv. No. C-6001 [022]

Uncoated	Nile E ₁	W ₂
----------	---------------------	----------------

Body fragmented (reconstructed shape); globular type. Md: 22.00 cm; Wd: 0.80 cm; H₁: 10.20 + x cm; made in parts; throwing lines outside and inside; smoothed on the wheel. Smoked on the lower part.

No. 7: jar (Fig. 1:1), Inv. No. C-6001 [016]

Uncoated	Nile B ₂	W ₂
----------	---------------------	----------------

Rim (1/8) sherd; articulated vertical interior rim. Rd: 10.00 cm; Wd: 0.60 cm; H₁: 3.20 + x

cm. Throwing lines inside; smoothed on the wheel.

No. 8: jar (Fig. 1:1), Inv. No. C-6001 [054]

Uncoated	Nile B ₂	W ₂
----------	---------------------	----------------

Rim sherd (1/16); vertical direct rim. Rd: 14.00 cm; Wd: 0.60 cm; H₁: 4.00 + x cm; throwing lines inside; smoothed on the wheel

No. 9: jar (Fig. 1:1), Inv. No. C-6001 [053]

Uncoated	Nile B ₂	W ₂
----------	---------------------	----------------

Rim sherd (7/32); vertical slightly articulated interior rim, round lip. Rd: 9.00 cm; Wd: 0.50 cm; H₁: 5.50 + x cm; throwing lines inside; smoothed on the wheel.

No. 10: jar (Fig. 1:1), Inv. No. C-6001 [055]

Uncoated	Nile B ₂	W ₂
----------	---------------------	----------------

Rim sherd (1/16); slightly everted direct rim. Rd: 12.00 cm; Wd: 0.60 cm; H₁: 3.50 + x cm; throwing lines inside; made in parts; smoothed on the wheel.

No. 11: jar (Fig. 1:1), Inv. No. C-6001 [014]

Uncoated	Nile B ₂	W ₂
----------	---------------------	----------------

Rim (3/32) sherd; articulated everted rim. Rd: 9.80 cm; Wd: 0.65 cm; H₁: 3.20 + x cm; throwing lines inside; smoothed on the wheel.

No. 12: jar (Fig. 1:1), Inv. No. C-6001 [017]

Uncoated	Nile B ₂	W ₂
----------	---------------------	----------------

Rim (1/16) sherd; articulated everted exterior rim, trimmed lip. Rd: 16.00 cm; Wd: 0.70 cm; H₁: 2.50 + x cm; throwing lines inside; smoothed on the wheel.

No. 13: jar, Inv. No. C-6001 [050]

Uncoated	Nile B ₂	Ha ₂
----------	---------------------	-----------------

Handle fragment; Hd: 2.39 x 1.70 cm; throwing lines inside; smoothed on the wheel.

No. 14: jar, Inv. No. C-6001 [008]

Nile B ₂	W ₂	base finished on the wheel
---------------------	----------------	----------------------------

Base, 1/1; pointed base; throwing lines on the base; smoothed on the wheel. Others, 1/2 base. Nile C₁, 1 base.

No. 15: storage jar (Fig. 1:1), Inv. No. C-6001 [018]

Uncoated	Nile B ₂	W ₂
----------	---------------------	----------------

Rim (1/8) sherd; articulated inverted exterior and interior rim, rounded lip. Rd: 23.00 cm; Wd: 0.50 cm, H₁: 2.80 + x cm; made in parts; throwing lines inside; smoothed on the wheel.

No. 16: storage jar, Inv. No. C-6001 [052]

Uncoated	Nile B ₂	W ₂
----------	---------------------	----------------

Rim sherd (3/16); everted articulated exterior rim, folded lip. Rd: 20.00 cm; Wd: 1.00 cm, H₁: 5.00 + x cm; throwing lines inside; smoothed on the wheel.

No. 17: storage jar (Fig. 1:2), Inv. No. C-6001 [001]

Uncoated	Nile B ₂	W ₂
----------	---------------------	----------------

Rim sherd (3/32); everted articulated interior and exterior rim, rounded lip. Rd: 30.00 cm; Wd: 0.60 cm; H₁: 3.00 + x cm; made in parts; throwing lines inside; smoothed on the

wheel.

No. 18: storage jar (Fig. 1:2), Inv. No. C-6001 [002]

Uncoated	Nile B ₂	W ₂
----------	---------------------	----------------

Rim sherd (1/32); everted articulated interior and exterior rim, rounded lip. Rd: 20.00 cm; made in parts; string marks; throwing lines inside; smoothed on the wheel.

No. 19: storage jar (Fig. 1:2), Inv. No. C-6001 [003]

Uncoated	Nile B ₂	W ₂
----------	---------------------	----------------

Rim sherd (1/16); Rd: 30.00 cm; Wd: 0.90 cm; H₁: 7.00 + x cm; throwing lines inside; smoothed on the wheel.

No. 20: storage jar (Fig. 1:2), Inv. No. C-6001 [005]

Uncoated	Nile B ₂	W ₂
----------	---------------------	----------------

Rim sherd, 1/8; everted direct rim. Rd: 24.00 cm; Wd: 1.20 cm; H₁: 2.90 + x cm; throwing lines inside; smoothed on the wheel.

No. 21: storage jar (Fig. 1:2), Inv. No. C-6001 [006]

Uncoated	Nile B ₂	W ₂
----------	---------------------	----------------

Rim (5/32) and body sherd; exterior flattened rim. Rd: 20.00 cm; Wd: 0.70 cm; H₁: 7.50 + x cm; string marks, made in parts; throwing lines inside; smoothed on the wheel. Another, Rd 30.00 cm 5/32.

No. 22: storage jar (Fig. 1:2), Inv. No. C-6001 [007]

Uncoated	Nile B ₂	W ₂ + Ha ₂
----------	---------------------	----------------------------------

Rim (1/16) sherd and swelling of the handle. Rd: 24.00 cm; Wd: 0.60 cm; H₁: 5.00 + x cm; finger marks on the handle; smoothed.

No. 23: storage jar, Inv. No. C-6001

Uncoated	Nile C ₂	W ₂
----------	---------------------	----------------

Body sherd and swelling of the handle; smoothed on the wheel.

No. 24: storage jar, Inv. No. C-6001 [010]

Uncoated	Nile B ₂	Ha ₂
----------	---------------------	-----------------

Handle fragment; Hd: 3.10 x 2.50 cm; smoothed. Another, eroded.

No. 25: amphora (Fig. 1:2), Inv. No. C-6001 [009]

Uncoated	Nile B ₂	W ₂
----------	---------------------	----------------

Rim (3/32) sherd; inverted articulated exterior and interior rim. Rd: 9.00 cm; Wd: 0.80 cm; H₁: 3.60 + x cm; smoothed on the wheel.

No. 26: amphora (Fig. 1:2), Inv. No. P1168A (Drawing No. 0911)

Coated	Nile B ₂	W ₂	W	ox.	2
--------	---------------------	----------------	---	-----	---

Base and body fragments; round base. Md: 26.00 + x cm; H₁: 33.80 + x cm; H₂: ca. 26.00 cm. Surface colour: 5YR 6/4 light reddish brown; 7.5YR 6/4 light brown slip. Break: 10YR 6/3 pale brown core; 7.5YR 6/6 reddish yellow oxidation zones. Technical details: throwing lines inside; made in parts. Surface treatment: smoothed on the wheel.

Pottery with special functions

No. 27: lid (Fig. 1:2), Inv. No. C-6001 [012]

Uncoated	Nile B ₂	W ₂
----------	---------------------	----------------

Rim (1/8) sherd; Rd: 23.00 cm; Wd: 0.70 cm; H₁: 3.50 + x cm; throwing lines outside and inside; smoothed on the wheel; smoked inside. Another, Rd: 24.00 cm 1/32

No. 28: bakery tray (Fig. 1:3), Inv. No. P1100A (Drawing No. 0465-466)

Uncoated	Nile C ₂ c.	W ₁	Ha	ox.	2
----------	------------------------	----------------	----	-----	---

Complete, fragmentary; mended. Rd: 24.00 cm 1/2; Bd: 23.00 cm; H₁: 5.50 cm. VI: 436. Surface colour: 2.5YR 5/2 weak red. Break: 10YR 5/2 greyish brown. Surface treatment: smoothed. Smoked inside and outside (used as a lid). Others, Rd 18.00 cm 1/16 and Bd 16.00 cm 1/8; Rd: 21.00 cm and Bd: 17.00 cm.

No. 29: tray, Inv. No. C-6001

Uncoated	Nile C ₂	Ha ₁
----------	---------------------	-----------------

Body fragment; uneven.

No. 29bis: "pigeon pot" (Fig. 1:3), Inv. No. P1162A (Drawing No. 0634)

Uncoated	Nile B ₂	W ₂	W	Ox.	2
----------	---------------------	----------------	---	-----	---

Incomplete, fragmentary; mended; base and body fragment; flat base. Md: 15.00 + x cm; Wd: 0.55 cm; Bd: 4.50 cm; H₁: 9.80 + x cm. Surface colour: 2.5YR 5/6 red. Break: 2.5YR 4/4 reddish brown. Technical details: throwing lines inside and outside. Surface treatment: smoothed on the wheel. *Find No. 006.*

Egyptian marls

Household ware

No. 30: jar, Inv. No. C-6001. Marl A₄, body sherd; smoothed on the wheel.

No. 31: jar, Inv. No. C-6001 [041]

Uncoated	Marl F + limestone	W ₂
----------	--------------------	----------------

Rim (3/32) sherd (reconstructed shape); Rd: 5.80 cm; smoothed on the wheel.

No. 32: amphora (Fig. 1:3), Inv. No. C-6001 [040]

Uncoated	Marl F	W ₂
----------	--------	----------------

Shoulder fragment; "torpedo" type. Md: ca. 27.00 cm; Wd: 0.60 cm; H₁: 6.00 + x cm; throwing lines inside; smoothed on the wheel.

b) North Sinai/South Palestine pottery

Household ware

No. 33: amphora, Inv. No. C-6001 [066], II.TG 10, body sherds.

c) Imported household ware

Levantine household ware

No. 34: amphora (Fig. 1:3), Inv. No. C-6001 [024]

Uncoated	IV.TG 01	W ₂
----------	----------	----------------

Shoulder fragment; "torpedo" type. Md: ca. 21.00 cm; Wd: 0.80 cm; H₁: 6.00 + x cm; smoothed on the wheel.

No. 35: amphora, Inv. No. C-6001 [063], IV.TG 01, body sherds.

No. 36: amphora (Fig. 1:4), Inv. No. C-6001 [028]

Uncoated	IV.TG 03	W ₂
----------	----------	----------------

Rim (1/4) sherd; Rd: 9.00 cm; Wd: 0.70 cm; H₁: 3.60 + x cm; smoothed on the wheel.

No. 37: amphora (Fig. 1:4), Inv. No. C-6001 [036]

Uncoated	IV.TG 03	W ₂ + Ha ₂
----------	----------	----------------------------------

Shoulder fragment and handle; “torpedo” type. Md: ca. 25.00 cm; Wd: 1.00 cm; H₁: 8.20 + x cm; Hd: 2.30 x 1.70 cm; throwing lines inside; applied handle; smoothed.

No. 38: amphora (Fig. 1:4), Inv. No. C-6001 [037]

Uncoated	IV.TG 03	W ₂ + Ha ₂
----------	----------	----------------------------------

Shoulder fragment and handle; “torpedo” type. Md: ca. 27.00 cm; Wd: 0.50 cm; H₁: 5.00 + x cm Hd: 2.40 x 1.70 cm; throwing lines inside; applied handle; smoothed.

No. 39: amphora, Inv. No. C-6001 [064], IV.TG 03, body sherds.

No. 40: amphora, Inv. No. C-6001 [068], IV.TG 05, body sherds.

No. 41: amphora, Inv. No. C-6001 [067], IV.TG 07, body sherds.

No. 42: amphora (Fig. 1:4), Inv. No. C-6001 [039]

Uncoated	IV.TG 11	W ₂
----------	----------	----------------

Rim (1/8) sherd; Rd: 10.00 cm; Wd: 0.70 cm; H₁: 5.00 + x cm; smoothed on the wheel.

No. 43: amphora (Fig. 1:4), Inv. No. C-6001 [030]

Uncoated	IV.TG 11	W ₂
----------	----------	----------------

Shoulder fragment; “torpedo” type. Md: ca. 22.00 cm; Wd: 0.70 cm; H₁: 4.80 + x cm; smoothed on the wheel.

No. 44: amphora, Inv. No. C-6001 [065], IV.TG 11, body sherds.

No. 45: amphora, Inv. No. C-6001 [078], IV.TG 18, body sherds.

No. 46: amphora, Inv. No. C-6001 [071], IV.TG 19, body sherds.

No. 47: amphora, Inv. No. C-6001 [074], IV.TG 24, body sherds.

No. 48: amphora, Inv. No. C-6001 [070], IV.TG 24, body sherds.

No. 49: amphora, Inv. No. C-6001 [069], IV.TG 29, body sherds.

No. 50: amphora, Inv. No. C-6001 [077], IV.TG 31, body sherds.

No. 51: amphora (Fig. 1:4), Inv. No. C-6001 [025]

Uncoated	IV.TG 51	W ₂
----------	----------	----------------

Rim (1/4) sherd; Rd: 10.00 cm; Wd: 0.30 cm; H₁: 3.50 + x cm; smoothed on the wheel.

No. 52: amphora (Fig. 1:5), Inv. No. C-6001 [038]

Uncoated	IV.TG 51	W ₂ + Ha ₂
----------	----------	----------------------------------

Shoulder fragment and handle; “torpedo” type. Md: ca. 26.00 cm; Wd: 1.00 cm; H₁: 8.80 + x cm; Hd: 2.60 x 1.50 cm; applied handle; throwing lines inside; smoothed.

No. 53: amphora (Fig. 1:5), Inv. No. C-6001 [033]

Uncoated	IV.TG 51	W ₂ + Ha ₂
----------	----------	----------------------------------

Shoulder fragment and handle; “torpedo” type. Md: ca. 22.00 cm; Wd: 1.00 cm; H₁: 8.00 + x cm; Hd: 2.80 x 2.20 cm; applied handle; throwing lines inside; smoothed.

No. 54: amphora (Fig. 1:5), Inv. No. C-6001 [031]

Uncoated	IV.TG 51	W ₂
----------	----------	----------------

Shoulder fragment; “torpedo” type. Md: ca. 28.00 cm; Wd: 0.70 cm; H₁: 8.80 + x cm; throwing lines inside; smoothed on the wheel.

No. 55: amphora, Inv. No. C-6001 [072], IV.TG 51, body sherds.

No. 56: amphora (Fig. 1:5), Inv. No. C-6001 [027]

Uncoated	IV.TG 52	W ₂
----------	----------	----------------

Rim (5/32) sherd; Rd: 12.00 cm; Wd: 0.70 cm; H₁: 3.60 + x cm; smoothed on the wheel.

No. 57: amphora (Fig. 1:5), Inv. No. C-6001 [029]

Uncoated	IV.TG 52	W ₂
----------	----------	----------------

Shoulder fragment; “torpedo” type. Md: ca. 24.00 cm; Wd: 0.70 cm; H₁: 5.10 + x cm; throwing lines inside; smoothed on the wheel.

No. 58: amphora, Inv. No. C-6001 [011]

Uncoated	IV.TG 52	Ha ₂
----------	----------	-----------------

Handle fragment; Hd: 3.00 x 1.70 cm ; smoothed.

No. 59: amphora, Inv. No. C-6001 [060], IV.TG 52, body sherds.

No. 60: amphora, Inv. No. C-6001 [073], IV.TG 52, body sherds.

No. 61: amphora, Inv. No. C-6001 [079], IV.TG 53, body sherds.

Cypriote household ware

No. 62: amphora, Inv. No. C-6001 [076], VI.TG 44. body sherds.

No. 63: amphora (Fig. 1:6), Inv. No. C-6001 [026]

Uncoated	VI.TG 40	W ₂
----------	----------	----------------

Rim (1/16) sherd; Rd: 11.00 cm; Wd: 0.60 cm; H₁: 3.00 + x cm; smoothed on the wheel.

No. 64: amphora (Fig. 1:6), Inv. No. C-6001 [032]

Uncoated	VI.TG 49	Ha ₂ + W ₂
----------	----------	----------------------------------

Shoulder fragment and handle; “torpedo” type. Md: ca. 23.00 cm; Hd: 2.50 x 1.80 cm; applied handle; throwing lines inside; smoothed.

II.- Finds***Personal objects******Beads***

No. 65: bead (Fig. 1:6), Inv. No. F0585 (Drawing No. 0445). Complete; faience; moulded. 0.80 x 0.30 x 0.60 cm; colour: 10YR 6/3 (pale brown). Description: truncated cone; perforation: 0.5-1 mm; 10 grooves. SCA No. 4011. *Find No. 001*.

No. 66: bead (Fig. 1:6), Inv. No. F0587A (Drawing No. 0456). Complete; faience; moulded. 0.80 x 0.35 cm; colour: 10YR 6/2 (light brownish grey); cylindrical shape; perforation: 1 mm. *Find No. 002*.

No. 67: bead (Fig. 1:6), Inv. No. F0921A (Drawing No. 0913). Complete; shell (*Ciprea albina*). 1.12 x 0.90 x 0.30 cm.

Tool

No. 68: grinding stone (Fig. 1:6), Inv. No. F0981A (Drawing No. 0954). Complete; limestone? Weight: 61.00 gr. 6.70 x 5.10 cm x 2.00 cm. Subtype: polisher? Double. Characteristics: rounded edge. Raw material quality: very fine. Degree of wear: 3-Hard. Wear marks: striations. Stroke: sub-parallel.

Suspended weight

No. 69: loom weight (Fig. 1:7), Inv. No. F0816A (Drawing No. 0453). Fragmentary (1/2 preserved) ; limestone. 5.20 x 4.90 x 2.60 cm. Conical shape. *Find No. 008*.

No. 70: net weight (Fig. 1:7), Inv. No. F0911A (before Inv. No. F0911B. Drawing

No. 1087). Complete; limestone. Weight: 92.00 gr. 6.30 x 3.40 x 3.30 cm. *Find No. 005.*

Weight

No. 71: net weight (Fig. 1:8), Inv. No. F0814 (Drawing No. 0511). Complete; limestone. 8.20 x 4.50 x 3.20 cm; a stringing groove. Function: fishing? SCA No. 4004. *Find No. 011.*

Stone vessel

No. 72: bowl (Fig. 1:8), Inv. No. F1091A (before Inv. No. F0928B. Drawing No. 0922). Fragmentary; limestone; wall fragment. Rd: ---; Wd: 2.00 cm.

Objects of unknown use

No. 73: fragment of an object, Inv. No. F0615A. Faience. 1.34 x 0.93 x 0.60 cm; colour: 5Y 8/1 white. *Find No. 004.*

No. 74: fragment of an object, Inv. No. F0616A. Faience; moulded. 1.62 x 1.04 x 0.90 cm; colour: Chart 1 for gley 7/5 GY light greenish grey, 7/10 GY light greenish grey and 10R 3/3 dusky red; irregular shape. *Find No. 003.*

No. 75: fragment of an object, Inv. No. F0689A. Faience; moulded. 1.60 x 1.00 x 0.55 cm; colour: 10YR 5/2 (greyish brown) and 7.5YR 4/2 (brown). Part of a wdjat? *Find No. 007.*

L0517 (Fig. 2)

Pottery

Egyptian pottery

Nile silt clay

Household ware

No. 1: bowl (Fig. 2), Inv. No. C-6020 [002]

Uncoated	Nile B ₂	W ₂
----------	---------------------	----------------

Rim sherd (1/16); incurved flattened rim. Rd: 35.00 cm; Wd: 0.80 cm; H₁: 5.90 + x cm; made in parts; throwing lines outside and inside; smoothed on the wheel.

No. 2: jar (Fig. 2), Inv. No. C-6020 [004]

Uncoated	Nile B ₂	W ₂
----------	---------------------	----------------

Rim sherd (3/32); everted direct rim. Rd: 14.00 cm; Wd: 0.60 cm; H₁: 4.30 + x cm; made in parts; throwing lines inside; smoothed on the wheel. Another: Rd 10.00 cm 1/4.

No. 3: storage jar (Fig. 2), Inv. No. C-6020 [001]

Uncoated	Nile B ₂	W ₂
----------	---------------------	----------------

Rim sherd (1/4); long neck; vertical articulated interior and exterior rim; Rd: 24.00 cm; Wd: 1.30 cm; H₁: 9.70 + x cm; made in parts; throwing lines inside; smoothed on the wheel.

No. 4: storage jar (Fig. 2), Inv. No. C-6020 [003]

Uncoated	Nile B ₂	W ₂
----------	---------------------	----------------

Rim sherd (1/32); vertical articulated exterior rim, rounded lip. Rd: 28.00 cm; Wd: 0.60 cm; H₁: 4.10 + x cm; throwing lines inside; smoothed on the wheel. Others, Rd: 24.00 cm 1/4, Rd: 30.00 cm 3/32.

No. 5: storage jar, Inv. No. C-6020 [004bis]

Uncoated	Nile B ₂	W ₂
----------	---------------------	----------------

Body sherd near the base; made in parts; throwing lines inside; fingerprints inside; smoothed on the wheel.

No. 6: storage jar, Inv. No. C-6020 [003bis]

Uncoated	Nile B ₂	W ₂
----------	---------------------	----------------

Body sherd near the base; made in parts; throwing lines inside; smoothed on the wheel.

Body sherds, Nile B₂: 7.00 dm².

L0518 (Fig. 3)

Pottery

Egyptian pottery

Nile silt clay

Egyptian household ware

No. 1: large bowl (Fig. 3), Inv. No. C-6029 [007]

Uncoated	Nile B ₂	W ₁
----------	---------------------	----------------

Rim sherd (1/32). Rd: 36.00 cm; Wd: 1.50 cm; H₁: 4.20 + x cm; throwing lines outside and inside; smoothed on the wheel; overfired.

No. 2: cooking pot, Inv. No. C-6029 [006]

Uncoated	Nile B ₂	W ₂
----------	---------------------	----------------

Body sherd; smoked outside.

No. 3: jar (Fig. 3), Inv. No. C-6029 [005]

Uncoated	Nile B ₂	W ₂
----------	---------------------	----------------

Rim sherd (1/32); slightly everted direct rim. Rd: 10.00 cm; Wd: 0.60 cm; H₁: 3.60 + x cm; throwing lines inside; smoothed on the wheel.

No. 4: jar, Inv. No. C-6029 [004]

Uncoated	Nile B ₂	W ₂	base finished on the wheel
----------	---------------------	----------------	----------------------------

Base fragment; pointed base; eroded.

L0546 (Fig. 4)

Pottery

a) Egyptian pottery

Nile silt clay

Household ware

No. 1: jar (Fig. 4), Inv. No. C-6023 [002]

Uncoated	Nile B ₂	W ₂
----------	---------------------	----------------

Rim sherd (1/16); vertical direct rim. Rd: 10.00 cm; Wd: 0.70 cm; H₁: 4.20 + x cm; throwing lines and grooves inside; smoothed on the wheel.

No. 2: jar, Inv. No. C-6023 [005]

Uncoated	Nile B ₂	W ₂
----------	---------------------	----------------

Body sherd; Md: ca. 23.00 cm; made in parts; throwing lines inside; smoothed on the wheel.

No. 3: storage jar, Inv. No. C-6023 [003]

Uncoated	Nile B ₂	W ₂
----------	---------------------	----------------

Body sherd and swelling of the handle; throwing lines inside; smoothed on the wheel.

No. 4: storage jar, Inv. No. C-6023 [001]

Uncoated	Nile B ₂	Ha ₂
----------	---------------------	-----------------

Handle fragment; Hd: 3.30 x 1.60 cm; fingerprints on the surface; smoothed.

Egyptian marl

Household ware

No. 5: amphora, Inv. No. C-6023 [006], Marl A₄, body sherds; ribbed surface.

No. 6: amphora, Inv. No. C-6023 [004], Marl A₄, body sherds: 2 dm².

b) North Sinai/South Palestine pottery

Household ware

No. 7: amphora (Fig. 4), Inv. No. P2042A (Drawing No. 0709)

Uncoated	II? TG 59	W ₂	---	med.	3
----------	-----------	----------------	-----	------	---

Rim, neck and shoulder fragment; "torpedo" type, inverted direct rim. Rd: 12.00 cm 1/16; Nd: 12.00 cm; Md: 26.00 cm; Wd: 0.90 cm; H₁: 5.80 + x cm. Surface colour: 10YR 8/4 very pale brown. Break: 7.5YR 8/6 reddish yellow core; 7.5YR 7/2 pinkish grey oxidation zones. Throwing lines inside. Surface treatment: smoothed on the wheel.

L0547 (Fig. 5)

I.- Pottery

a) Egyptian pottery

Nile silt clay

Egyptian fine ware

No. 1: juglet, Inv. No. C-6021 [001].

RP	Nile B ₂	W ₂
----	---------------------	----------------

Body sherd. Md: ca. 9.00 cm; Wd: 0.80 cm; H₁: 7.00 + x cm; throwing lines inside; red slip; vertically burnished.

Egyptian painted ware

Black on Red slip ware

No. 2: jar (Fig. 5), Inv. No. P1136A (Drawing No. 0914)

RPMO	Nile B ₂	W ₂	W	re.	2-3
------	---------------------	----------------	---	-----	-----

Base and body fragments; rounded base. Md: 17.50 + x cm; Wd: 0.50 cm; H₁: 9.00 + x cm. Surface colour: 10R 5/6 red slip. Break: 2.5YR 2.5/1 reddish black core (thick); 5/8 red oxidation zones (thin). Technical details: made in parts; throwing lines inside. Decoration: three horizontally painted bands on the base, 3 mm wide, and above a band 13 mm wide; four horizontally painted bands on the body, 5 mm wide; 10R 5/1 reddish grey. Surface treatment: polished, medium lustre.

Egyptian household ware

No. 3: bowl (Fig. 5), Inv. No. C-6021 [004]

Uncoated	Nile B ₂	W ₂
----------	---------------------	----------------

Rim sherd (1/32); everted direct rim. Rd: 18.00 cm; Wd: 1.00 cm; H₁: 3.40 + x cm; throwing lines outside and inside; smoothed on the wheel.

No. 4: jar (Fig. 5), Inv. No. C-6021 [003]

Uncoated	Nile B ₂	W ₂
----------	---------------------	----------------

Rim sherd (3/16); vertical direct rim. Rd: 8.00 cm; Wd: 0.50 cm; H₁: 3.50 + x cm; made in parts; throwing lines inside; smoothed on the wheel.

No. 5: jar, Inv. No. C-6021 [002]

Uncoated	Nile B ₂	W ₂	base finished on the wheel
----------	---------------------	----------------	----------------------------

Base fragment (1/2); pointed base. Md: 9.00 + x cm; twisted with the finger after finished to make the base more pointed; smoothed on the wheel.

No. 6: jar, Inv. No. C-6021 [009]

Uncoated	Nile B ₂	W ₂	[base finished on the wheel]
----------	---------------------	----------------	------------------------------

Body sherd near the base; [pointed base].

No. 7: storage jar (Fig. 5), Inv. No. C-6021 [006]

Uncoated	Nile B ₂	W ₂
----------	---------------------	----------------

Rim sherd (3/16); slightly inverted articulated exterior rim, rounded lip. Rd: 20.00 cm; Wd: 0.90 cm; H₁: 3.20 + x cm; throwing lines inside; smoothed on the wheel.

No. 8: storage jar (Fig. 5), Inv. No. C-6021 [005]

Uncoated	Nile B ₂	W ₂
----------	---------------------	----------------

Rim sherd (1/16); inverted articulated exterior rim, folded rim. Rd: 31.00 cm; Wd: 0.90 cm; H₁: 4.30 + x cm; throwing lines inside; smoothed on the wheel.

No. 9: storage jar, Inv. No. C-6021 [007]

Uncoated	Nile B ₂	Ha ₂
----------	---------------------	-----------------

Handle fragment. Hd: 3.70 x 3.60 cm; finger marks on the surface; smoothed.

No. 10: storage jar, Inv. No. C-6021 [012]

Uncoated	Nile B ₂	W ₂
----------	---------------------	----------------

Body sherd and swelling of the handle; eroded.

Pottery with special functions**No. 11: bakery tray**, Inv. No. C-6021 [010]

Uncoated	Nile C ₁	W ₁
----------	---------------------	----------------

Fragment; eroded.

Egyptian marl**Household ware****No. 12: amphora**, Inv. No. C-6021 [015]

Uncoated	Marl F	W ₂
----------	--------	----------------

Shoulder fragment. Md: ca. 28.00 cm; throwing lines inside; smoothed on the wheel; eroded inside.

II.- Finds**Personal object**

No. 13: compound bead (Fig. 5), Inv. No. F0705A (Drawing No. 0457). Complete; faience; moulded. 0.42 x 0.31 cm; colour: Chart 1 for gley 6/10 BG greenish grey; cylindrical shape; perforation: 1.4 mm. *Find No. 002*.

Stone vessel

No. 14: bowl (Fig. 5), Inv. No. C-6004 [013]. Fragmentary; limestone; base fragment, round. Wd: 2.00 cm.

Objects of unknown use

No. 15: fragment of an object, Inv. No. F0712A. Bronze?. *Find No. 003*.

Weapon?

No. 16: fragment of a weapon? (Fig. 5), Inv. No. F0728A (Drawing No. 0618). Iron; melted. 7.10 x 5.10 x 0.80 cm. *Find No. 005.*

L0587 (Fig. 6)**Pottery****a) Egyptian pottery****Nile silt clay*****Egyptian household ware***

No. 1: bowl? (Fig. 6), Inv. No. C-6004 [009]

Uncoated	Nile B ₂	W ₂
----------	---------------------	----------------

Rim sherd (3/32) (reconstructed shape); everted direct rim. Rd: 24.00 cm; Wd: 0.60 cm; H₁: 3.50 + x cm; throwing lines outside and inside; smoothed on the wheel.

No. 2: jar (Fig. 6), Inv. No. C-6004 [008]

Uncoated	Nile B ₂	W ₂
----------	---------------------	----------------

Rim sherd (1/8); vertical direct rim. Rd: 12.00 cm; Wd: 0.50 cm; H₁: 4.00 + x cm; made in parts; throwing lines inside; smoothed on the wheel. Another, Rd: 12.00 cm 1/16.

No. 3: jar (Fig. 6), Inv. No. C-6004 [004]

Uncoated	Nile B ₂	W ₂
----------	---------------------	----------------

Rim sherd (1/8); long neck, vertical slightly articulated interior rim, round lip. Rd: 10.00 cm; Wd: 0.50 cm; H₁: 5.50 + x cm; throwing lines inside; smoothed on the wheel. Another, Rd: 9.00 cm 1/8. Rd: 10.00 cm.

No. 4: storage jar (Fig. 6), Inv. No. C-6004 [007]

Uncoated	Nile B ₂	W ₂
----------	---------------------	----------------

Rim sherd (3/32); inverted articulated interior and exterior rim, rounded lip. Rd: 24.00 cm; Wd: 1.00 cm; H₁: 4.80 + x cm; made in parts; throwing lines inside; smoothed on the wheel.

No. 5: storage jar (Fig. 6), Inv. No. C-6004 [006]

Uncoated	Nile B ₂	W ₂
----------	---------------------	----------------

Rim sherd (1/4) and swelling of the handle. Rd: 22.00 cm; Wd: 1.00 cm; H₁: 4.50 + x cm; made in parts; throwing lines inside; smoothed on the wheel.

No. 6: storage jar?, Inv. No. C-6004 [012]

Uncoated	Nile B ₂	Ha ₂
----------	---------------------	-----------------

Handle fragment. Hd: 2.70 x 1.90 cm; smoothed.

No. 7: storage jar, Inv. No. C-6004 [011]

Uncoated	Nile B ₂	W ₂	W
----------	---------------------	----------------	---

Base fragment; rounded base. Md: 18.00 + x cm; made in parts; throwing lines inside; fingerprints inside; smoothed on the wheel.

Pottery with special functions

No. 8: lid, Inv. No. C-6004 [010]

Uncoated	Nile B ₂	W ₂
----------	---------------------	----------------

Rim sherd (1/32). Rd: 20.00 cm; throwing lines outside and inside; smoothed on the wheel; smoked inside.

No. 9: tray, Inv. No. C-6004 [001]

Uncoated	Nile C ₂	Ha ₁
----------	---------------------	-----------------

Fragment; D: ca. 40.00 cm; uneven.

Egyptian marl clay

Fine ware

No. 10: juglet (Fig. 6), Inv. No. P7096A (Drawing No. 0936)

P	Marl F	W ₂	---	ox.	3
---	--------	----------------	-----	-----	---

Body fragment; globular type. Md: 8.30 + x cm; Wd: 0.70 cm; H₁: 3.00 + x cm. Surface colour: 7.5YR 8/3 pink self-slip. Break: 5YR 5/6 yellowish red. Technical details: made in parts; throwing lines inside. Surface treatment: polished, low lustre.

No. 11: amphora, Inv. No. C-6004 [002]

Uncoated	Marl F	W ₂
----------	--------	----------------

Body sherd. Md: ca. 22.00 cm; throwing lines inside; ribbed surface; smoothed on the wheel.

b) Imported pottery

Aegean household ware

No. 12: juglet (Fig. 6), Inv. No. P2020A (Drawing No. 0447)

Uncoated	≅ VII.TG 46 (Chian)	W ₂	---	ox.	3
----------	---------------------	----------------	-----	-----	---

Rim, neck and handle fragment. Akhziv type; everted direct rim. Rd: 5.10 cm; Nd: 2.40 cm; Wd: 0.60 cm; H₁: 6.60 + x cm; Hd: 0.70 x 0.70 cm. Surface colour: 5YR 6/6 reddish yellow. Break: 5YR 6/6 reddish yellow. Surface treatment: smoothed. *Find No. 010*.

L0589 (Fig. 7)

Pottery

a) Egyptian pottery

Nile silt clay

Household ware

No. 1: jar (Fig. 7), Inv. No. C-6002 [001]

Uncoated	Nile B ₂	W ₂
----------	---------------------	----------------

Rim sherd (3/16); slightly everted direct rim. Rd: 12.00 cm; Wd: 0.60 cm; H₁: 3.50 + x cm; made in parts; throwing lines inside; smoothed on the wheel. Another, Rd: 8.00 cm 5/32.

No. 2: jar, Inv. No. C-6002 [004]

Uncoated	Nile clay	W ₂	base finished on the wheel
----------	-----------	----------------	----------------------------

Base fragment; pointed base. Md: ca. 8.00 + x cm; made in parts; fingerprints inside; throwing lines inside, and outside on the base; smoothed on the wheel. Smoked inside.

No. 3: storage jar (Fig. 7), Inv. No. C-6002 [005]

Uncoated	Nile B ₂	W ₂
----------	---------------------	----------------

Rim fragment (1/4); vertical articulated exterior rim, rounded lip. Rd: 24.00 cm; Wd: 1.20 cm; H₁: 12.00 + x cm; made in parts; throwing lines inside; string marks; smoothed on the wheel.

Egyptian marls

Household ware

No. 4: amphora, Inv. No. C-6002 [003]

Uncoated	Marl A ₄	W ₂
----------	---------------------	----------------

Body sherd; Md: ca. 24.00 cm; throwing lines inside; ribbed surface.

No. 5: amphora, Inv. No. C-6002 [007]

Uncoated	Marl F	W ₂
----------	--------	----------------

Body sherd; Wd: 0.70 cm; throwing lines inside; smoothed on the wheel

b) Imported pottery

Levantine household ware

No. 6: amphora, Inv. No. C-6002 [008], IV.TG 07, body sherd.

No. 7: amphora, Inv. No. C-6002 [006]

Uncoated	IV.TG 52	W ₂
----------	----------	----------------

Rim sherd; Rd: 12.00 cm; smoothed on the wheel; eroded.

L0591 (Fig. 8)

Pottery

a) Egyptian pottery

Nile silt clay

Egyptian household ware

No. 1: widemouthed jar? (Fig. 8), Inv. No. P1108A (Drawing No. 0522)

Uncoated	Nile B ₂	W ₂	---	ox.	2
----------	---------------------	----------------	-----	-----	---

Rim, shoulder and body fragment; inverted rim. Rd: 19.00 cm 1/8; Md: 21.00 cm; H₁: 6.50 + x cm. Surface colour: 5YR 6/4 light reddish brown. Break: 2.5YR 4/4 reddish brown core; 5YR 4/3 reddish brown oxidation zones. Technical details: throwing lines inside; two grooves below the rim. Surface treatment: smoothed on the wheel.

No. 2: jar (Fig. 8), Inv. No. P1161A (Drawing No. 0530)

Uncoated	Nile B ₂	W ₂	base finished on the wheel	ox.	2
----------	---------------------	----------------	----------------------------	-----	---

Complete, fragmentary; pointed base. Rd: 8.10 cm 1/1; Nd: 7.85 cm; Md: 14.00 cm; H₁: 14.50 cm; H₂: 7.30 cm; H₃: 3.00 cm. VI: 97. Surface colour: 2.5YR 6/4 light reddish brown. Break: 2.5YR 6/4 light reddish brown. Technical details: throwing lines inside. Surface treatment: smoothed on the wheel. Observations: smoked outside except on the base. *Find No. 011.*

Pottery with special functions

No. 3: cover of an oven?, tray?, Inv. No. C-9053 [001]

Uncoated	Nile C ₂	Ha ₁
----------	---------------------	-----------------

Fragment; D: 50.00 cm, 1/16; uneven surface.

b) Imported pottery

Levantine household ware

No. 4: amphora, Inv. No. C-9053 [001], IV.TG 18, body sherd.

LEVEL II: Building F

1.- General description

Building F (Plan VIII and Plate XIII) –perhaps a complex structure comprising

more than one unit- was built in mud bricks without foundation trenches. Its orientation is NNW-SSE. Only its eastern part (some 275 m²) was exposed; the western one was covered by a rather thick deposit of Aeolian sand. Building F was severely deflated: only two to six courses of mud bricks are left and the floors have been swept away. In the excavated part, the walls delimit 16 rectangular spaces of very different size, from c. 1.50 x 1.60 m to c. 3 x 8.20 m.

The interpretation of a building, which has lost its floors and has been exposed only in part is rather difficult. Nevertheless, some considerations are possible. Five door sockets were found, some of them along with the corresponding door stops. Four sockets indicate a north-south circulation and the fifth, to the south of the building, corresponds to a door giving access from a room to an open area to the east where an oven had been placed.

In correspondence with the lines of circulation indicated by the door sockets, north-south walls L0535 and L0537 are rather thick (2 m and 2.50 m, respectively). The former one may consist of two adjoining walls, the eastern part made out of clayey mud bricks and the western one, of sandy mud bricks. In sum, it is possible that the exposed part of Building F consisted of at least two units. This possibility is strengthened by the existence of two activity areas disposed rather symmetrically to the north and south of the building and marked by external ovens that remain unexcavated. In the north, L0540 identifies two ovens very near each other, associated with pottery. L0541 corresponds to a third oven c. 6 m to the east. Oven L0542 is the one in the south.

One of the rooms of Building F (L0515) was affected by a fire, which burnt the mud bricks, preserving the imprints of the plant material used in them and also of the fingers of the brick makers. Perhaps, the fire took place when the building was already ruined, since neither the lower, carbonised part (**L0516**) nor the upper, oxidised upper part (**L0503**) of the fill seem to have been a floor. The heat also affected L0517, a layer underlying Building F.

No permanent structures were preserved in Area VI after the abandonment of Building F.

2.- Archaeological material

L0503 (Fig. 9)

I.- Pottery

a) Egyptian pottery

Nile silt clay

Fine ware

Egyptian painted ware

Monochrome ware

No. 1: jar (Fig. 9), Inv. No. P7097A (Drawing No. 0935)

WPMO	Nile B ₂	W ₂	---	ox.	2-3
------	---------------------	----------------	-----	-----	-----

Body sherd. Md: 11.0 cm; Wd: 0.50 cm; H₁: 3.00 + x cm; Hd: 0.90 x 0.70 cm. Surface colour: 2.5YR 5/6 red; 7.5YR 7/4 pink slip. Break: 2.5YR 5/6 red. Technical details: made in parts; throwing lines inside. Decoration: two horizontally painted bands, 4 and 6 mm wide, 2.5YR 4/1 dark reddish grey. Surface treatment: polished.

Egyptian household ware

No. 2: large bowl, Inv. No. C-6014 [005]

Uncoated	Nile B ₂	W ₂
----------	---------------------	----------------

Rim sherd; incurved rim; eroded.

No. 3: jar, Inv. No. C-6014 [004]

Uncoated	Nile B ₂	W ₂
----------	---------------------	----------------

Rim sherd (3/32); direct rim, short neck. Rd: 7.00 cm; Md: 8.00 + x cm; throwing lines inside; smoothed on the wheel.

No. 4: jar, Inv. No. C-6014 [002]

Uncoated	Nile B ₂	W ₂
----------	---------------------	----------------

Rim sherd (3/16); direct everted rim. Rd: 8.00 cm; throwing lines inside; smoothed on the wheel.

No. 5: jar, Inv. No. C-6014 [003]

Uncoated	Nile B ₂	W ₂ + Ha ₂
----------	---------------------	----------------------------------

Body and handle fragment. Md: 24.00 cm; Hd: 1.80 x 1.60 cm; throwing lines inside; smoothed.

Pottery with special functions

No. 6: "pigeon pot" (Fig. 9), Inv. No. C-6014 [001]

Uncoated	Nile B ₂	W ₂
----------	---------------------	----------------

Base sherd (7/32). Bd: 3.00 cm; Wd: 1.00 cm; H₁: 6.20 + x cm; made in parts; the hole was opened with the finger after throwing; smoothed on the wheel.

Egyptian marls

Household ware

No. 7: amphora, Inv. No. C-6014 [007], Marl A₄, body sherds, 0.50 dm²; ribbed surface.

b) Imported pottery

Levantine household ware

No. 8: amphora, Inv. No. C-6014 [006], IV.TG 52, body sherds.

II.- Finds

Personal objects

Beads

No. 9: bead (Fig. 9), Inv. No. F0589A (Drawing No.0463). Complete; faience; moulded. 0.50 x 0.20 cm; colour: 5YR 3/2 (dark reddish brown); cylindrical shape; perforation: 2 mm. *Find No. 008.*

No. 10: beads, twenty-four beads (Fig. 9; Plate 1), Inv. No. F0726 (Drawing No. 0450). Complete; faience; moulded. Beads No. 8: 0.50 x 0.10 cm, No. 14: 0.50 x 0.20 cm, and No. 18: 0.60 x 0.20 cm; cylindrical shape; reconstructed string. SCA No. 4012. *Find No. 001.*

Object of unknown use

No. 11: fragment of an object, Inv. No. F0743A. Bronze. 0.37 x 0.14 cm. *Find No. 002.*

L0516 (Fig. 10)

Pottery

a) Egyptian pottery

Nile silt clay

Egyptian household ware

No. 1: bowl (Fig. 10), Inv. No. C-6019 [003bis]

Uncoated	Nile B ₂	W ₂
----------	---------------------	----------------

Rim sherd (1/16); vertical direct rim. Rd: 20.00 cm; Wd: 0.60 cm; H₁: 2.30 + x cm; throwing lines outside and inside; smoothed on the wheel.

No. 2: bowl, Inv. No. C-6019 [007bis]

Uncoated	Nile B ₂	W ₂
----------	---------------------	----------------

Rim sherd (eroded).

No. 3: jar (Fig. 10), Inv. No. C-6019 [002bis]

Uncoated	Nile B ₂	W ₂
----------	---------------------	----------------

Rim sherd (1/16); vertical direct rim. Rd: 12.00 cm; Wd: 0.50 cm; H₁: 2.80 + x cm; made in parts; throwing lines inside; a groove inside below the rim; smoothed on the wheel.

No. 4: storage jar (Fig. 10), Inv. No. C-6019 [003]

Uncoated	Nile B ₂	W ₂
----------	---------------------	----------------

Rim sherd (1/8); slightly inverted direct rim. Rd: 20.00 cm; Wd: 0.70 cm; H₁: 4.00 + x cm; made in parts; throwing lines inside; smoothed on the wheel.

No. 5: storage jar (Fig. 10), Inv. No. C-6019 [001]

Uncoated	Nile B ₂	W ₂
----------	---------------------	----------------

Rim sherd (1/32); inverted articulated interior and exterior rim, rounded lip. Rd: 35.00 cm; Wd: 1.50 cm; H₁: 5.70 + x cm; made in parts; throwing lines inside; smoothed on the wheel.

Pottery with special functions

No. 6: lid (Fig. 10), Inv. No. C-6019 [002]

Uncoated	Nile B ₂	W ₂
----------	---------------------	----------------

Rim sherd (1/32). Rd: 32.00 cm; Wd: 0.60 cm; H₁: 2.00 + x cm; throwing lines outside and inside; smoothed on the wheel; smoked inside.

No. 7: tray, Inv. No. C-6019 [006]

Uncoated	Nile C ₂	W ₁
----------	---------------------	----------------

Fragment; D: ca. 50.00 cm; uneven.

Egyptian marls

Household ware

No. 8: jar (Fig. 10), Inv. No. C-6019 [001bis]

Uncoated	Marl A ₄	W ₂
----------	---------------------	----------------

Rim sherd (3/32); vertical articulated interior rim. Rd: 14.00 cm; Wd: 0.50 cm; H₁: 2.00 + x cm; throwing lines inside; smoothed on the wheel.

No. 9: amphora, Inv. No. C-6019 [005], Marl F + limestone, body sherd.

b) Imported pottery

Levantine household ware

No. 10: amphora, Inv. No. C-6019 [004], IV.TG 29: body sherd.

LEVEL III: Post-Building F

1.- Stratigraphic sequence

Locus	Description	Interpretation
L0521, L0520, L0519 and L0522	When in Square BA/54 an almost complete pot (L0519) was found in horizontal position inside a small pit (L0520) inside a <i>muna</i> (L0521) and filled by a dark sediment similar to L1001 (L0522), the possibility was considered that it could be an infant burial.	The pot (storage jar, Inv. No. P1160A) had no special contents.
L0553	This locus was exposed but no excavated.	
L0551	Sandy clay with charcoals. Pottery rather abundant.	Human frequentation.
L0552	Irregular ditch cutting L0551	
L0512	Sandy fill. Its upper part is very rich in salt and breaks in lumps. Some stray mud brick were found inside this sediment. L0512 fills ditch L0551.	Natural fill and human frequentation.
L1001	In Area VI, this dark, carbonaceous layer had been preserved only in lenses or patches.	Destruction layer.
L0507	Sandy clay. The clayey contents comes from decayed mud bricks of Building F.	Human frequentation.
L0505	A sedimentary lens very rich in fish bones	Small midden.
L0508	This sediment was exposed but not excavated in 1999. In its surface, a zoomorphic mud head was found.	
Topsoil	Sandy, rich in salt.	Aeolian unconsolidated sand.

2.- Archaeological material

L0507 (Fig. 11)

I.- Pottery

a) Egyptian pottery

Nile silt clay

Fine ware

Egyptian painted ware

Monochrome ware

No. 1: juglet (Fig. 11:1), Inv. No. P7103A (Drawing No. 938)

WPMO	Nile B ₂	W ₂	---	ox.	2
------	---------------------	----------------	-----	-----	---

Body sherd. Md: 10.00 + x cm; Wd: 0.30 cm; H₁: 2.00 + x cm. Surface colour: 7.5YR 6/4 light brown; 7/3 pink slip. Break: 2.5YR 5/6 red core; 7.5YR 6/4 light brown oxidation zones. Technical details: made in parts; fine throwing lines inside. Decoration: two horizontally painted bands, 3 mm wide, 5YR 4/1 dark grey. Surface treatment: polished, medium lustre.

Black on Red slip ware

No. 2: jar (Fig. 11:1), Inv. No. P1140A (Drawing No. 0630)

BPMO	Nile B ₂	W ₂	---	re.	2-3
------	---------------------	----------------	-----	-----	-----

Body sherd. Md: 16.00 cm; Wd: 0.40 cm; H₁: 3.10 + x cm. Surface colour: 10YR 4/4 dark yellowish brown slip. Break: 5YR 2.5/1 black. Technical details: throwing lines inside. Decoration: three horizontally painted bands, 3 mm wide; 10R 3/1 dark reddish grey. Surface treatment: polished, medium lustre.

Household ware

No. 3: bowl (Fig. 11:1), Inv. No. C-6022 [007]

Uncoated	Nile B ₂	W ₂
----------	---------------------	----------------

Rim sherd (1/32). Rd: 26.00 cm; Wd: 0.80 cm; H₁: 2.50 + x cm; throwing lines outside and inside; smoothed on the wheel.

No. 4: bowl (Fig. 11:1), Inv. No. C-6022 [009]

Uncoated	Nile B ₂	W ₂
----------	---------------------	----------------

Rim sherd (1/32); trimmed rim. Rd: 22.00 cm; Wd: 1.00 cm; H₁: 3.00 + x cm; throwing lines outside and inside; smoothed on the wheel. Another, Rd: 26.00 cm 1/32.

No. 5: jar (Fig. 11:1), Inv. No. C-6022 [010]

Uncoated	Nile B ₂	W ₂
----------	---------------------	----------------

Rim sherd (1/16); direct rim, long neck. Rd: 8.00 cm; Wd: 0.30 cm; H₁: 2.00 + x cm; throwing lines inside; smoothed on the wheel. Others, Rd: 10.00 cm ¼, Rd: 11.00 cm 1/8

No. 6: jar (Fig. 11:1), Inv. No. C-6011 [018]

Uncoated	Nile B ₂	W ₂
----------	---------------------	----------------

Rim sherd (1/32); everted rim. Rd: 16.00 cm; Wd: 0.60 cm; H₁: 1.50 + x cm; throwing lines inside; smoothed on the wheel.

No. 7: jar (Fig. 11:1), Inv. No. C-6011 [010]

Uncoated	Nile B ₂	W ₂
----------	---------------------	----------------

Rim sherd (1/8); everted direct rim. Rd: 10.00 cm; Wd: 0.40 cm; H₁: 4.20 + x cm; made in parts; throwing lines inside; smoothed on the wheel. Others, Rd 10.00 cm ½, Rd: 11.00 cm 7/32, Rd: 12.00 cm ¼, Rd: 18.00 cm 1/4.

No. 8: jar, Inv. No. C-6011 [004]

Nile B ₂	W ₂	Base finished on the wheel
---------------------	----------------	----------------------------

Base fragment; pointed base. Md: 9.00 + x cm; fingerprints inside; smoothed on the wheel. Others, 2 bases.

No. 9: storage jar (Fig. 11:1), Inv. No. C-6011 [011]

Uncoated	Nile B ₂	W ₂
----------	---------------------	----------------

Rim sherd (1/16); inverted articulated exterior rim, trimmed lip. Rd: 26.00 cm; Wd: 0.50 cm; H₁: 5.00 + x cm; made in parts; throwing lines inside; smoothed on the wheel. Another, Rd: 20.00 cm 3/32.

No. 10: storage jar (Fig. 11:1), Inv. No. C-6011 [014]

Uncoated	Nile B ₂	W ₂
----------	---------------------	----------------

Rim sherd (1/8); exterior rim, folded lip. Rd: 34.00 cm; Wd: 0.60 cm; H₁: 3.00 + x cm; throwing lines inside; smoothed on the wheel; eroded inside. Others: Rd: 24.00 cm 3/32, Rd: 24.00 cm 3/32, Rd: 32.00 cm 1/8, Rd: 36.00 cm 1/8.

No. 11: storage jar (Fig. 11:1), Inv. No. C-6011 [008]

Uncoated	Nile B ₂	W ₂
----------	---------------------	----------------

Rim sherd (1/8); thickened rim. Rd: 20.00 cm; Wd: 1.00 cm; H₁: 5.50 + x cm; grooves on the rim, inside; throwing lines inside; smoothed on the wheel.

No. 12: storage jar (Fig. 11:2), Inv. No. C-6011 [005]

Uncoated	Nile B ₂	W ₂
----------	---------------------	----------------

Rim sherd (7/64); exterior and interior lip. Rd: 22.00 cm; Wd: 1.20 cm; H₁: 7.50 + x cm; made in parts; throwing lines inside; smoothed on the wheel.

No. 13: storage jar, Inv. No. C-6011 [003]

Uncoated	Nile B ₂	Ha ₂
----------	---------------------	-----------------

Handle fragment. Hd: 3.50 x 3.40 cm; finger marks on the surface; smoothed. Others, Hd: 3.00 x 1.80 cm; Hd: 3.20 x 2.00 cm.

No. 14: storage jar, Inv. No. C-6022 [001]

Uncoated	Nile B ₂	W ₂	base finished on the wheel
----------	---------------------	----------------	----------------------------

Base fragment; pointed base. Md: 11.00 + x cm; made in parts, throwing lines inside; fingerprints inside; smoothed on the wheel. Another, 1 base.

No. 15: storage jar, Inv. No. C-6011 [015]

Uncoated	Nile B ₂	W ₂
----------	---------------------	----------------

Body fragment. Md: 34.00 + x cm; made in parts; throwing lines inside; fingerprints inside; smoothed on the wheel.

Pottery with special functions

No. 16: lid (Fig. 11:2), Inv. No. C-6022 [004]

Uncoated	Nile B ₂	W ₂
----------	---------------------	----------------

Rim and body fragment (5/32). Rd: 28.00 cm; Wd: 1.00 cm; H₁: 6.00 + x cm. Made in parts; throwing lines outside and inside; smoothed on the wheel; smoked inside and on the rim outside. Another, Rd: 18.00 cm 1/16.

No. 17: bakery tray (Fig. 11:2), Inv. No. C-6022 [003]

Uncoated	Nile C ₂	W ₁
----------	---------------------	----------------

Rim sherd, 1/16. Rd: 20.00 cm; H₁: 2.50 + x cm; uneven.

No. 18: tray (Fig. 11:2), Inv. No. C-6011 [001]

Uncoated	Nile C ₂	Ha ₁
----------	---------------------	-----------------

Complete, fragmentary. D: ca. 50.00 cm 1/16; H₁: 5.00 + x cm; uneven. Another fragment.

Egyptian marls

Household ware

No. 19: jar, Inv. No. C-6022 [022]. Marl A₄, body sherds: 0.50 dm².

No. 20: amphora, Inv. No. C-6011 [020]. Marl A₄, body sherds, ribbed surface: 0.25 dm².

No. 21: amphora, Inv. No. C-6022 [023]. Marl F, body sherd, 1 dm²; smoothed on the wheel.

No. 22: amphora, Inv. No. C-6022 [020]. Marl F + limestone, body sherd.

No. 23: amphora, Inv. No. C-6022 [019]. Marl F + limestone, body sherds, 1 dm².

b) North Sinai/South Palestine pottery

Household ware

No. 24: amphora, Inv. No. C-6022 [018], II.TG 09, body sherds.

No. 25: amphora, Inv. No. C-6022 [016], II.TG 10, body sherds.

c) Imported household ware

Levantine household ware

No. 26: amphora, Inv. No. C-6022 [014], IV.TG 03, body sherd.

No. 27: amphora, Inv. No. C-6022 [017], IV.TG 23, body sherd.

No. 28: amphora, Inv. No. C-6022 [013], IV.TG 24, body sherd.

No. 29: amphora (Fig. 11:2), Inv. No. P1103A (Drawing No. 0711)

Uncoated	IV.TG 31	W ₂	---	me.	3
----------	----------	----------------	-----	-----	---

Shoulder fragment, "torpedo" type, flat shoulder. Md: ca. 24.00 cm; Wd: 0.50 cm; H₁: 3.10 + x cm. Surface colour: 2.5YR 8/4 pink- 2.5YR pinkish white self-slip. Break: 2.5YR 5/1 reddish grey core; 2.5YR 7/6 light red and 5YR 7/6 reddish yellow oxidation zones. Technical details: throwing lines inside. Surface treatment: smoothed on the wheel. Eroded inside.

No. 30: amphora, Inv. No. C-6022 [015], IV.TG 31, body sherd.

No. 31: amphora, Inv. No. C-6022 [012], IV.TG 51 (=TD IV.19), body sherd.

Cypriote fine ware

White Painted ware

No. 32: jar (Fig. 11:2), Inv. No. P1180A (Drawing No. 0702)

WPMO	VI.TG 40	W ₂	---	re.	3
------	----------	----------------	-----	-----	---

Body sherd. Md: ca. 13.00 cm; Wd: 0.35 cm; H₁: 2.20 + x cm. Surface colour: 10YR 6/2 light brownish grey slip. Break: 10YR 5/2 greyish brown. Decoration: three horizontally painted lines, 10YR 2.5/1 reddish black. Surface treatment: polished, low lustre.

Cypriote household ware

No. 33: amphora, Inv. No. C-6022 [011], VI.TG 49, body sherd.

II.- Finds

Tools

No. 34: fish hook? (Fig. 11:2), Inv. No. F0690A (Drawing No. 0640). Bronze; melted. 2.50 x 2.50 x 0.60 cm. *Find No. 001.*

L0508 (Fig. 12)

I.- Pottery

Egyptian pottery

Nile silt clay

Household ware

No. 1: jar (Fig. 12), Inv. No. C-6025 [001]

Uncoated	Nile B ₂	W ₂
----------	---------------------	----------------

Rim sherd (1/16); direct rim. Rd: 12.0 cm; Wd: 0.50 cm; H₁: 3.30 + x cm; made in parts; smoothed on the wheel.

Pottery with special functions

No. 2: tray, Inv. No. C-6025 [002]

Uncoated	Nile C ₂	Ha ₁
----------	---------------------	-----------------

Fragment. D: ca. 50.00 cm; uneven surface.

Egyptian marl**Household ware**

No. 3: amphora, Marl F, body sherd.

II.- Finds

No. 4: mould (Fig. 12), Inv. No. F0926A (Drawing No. 940). Fragmentary; clay; hand-made. 7.00 x 3.50 x 3.50 cm; colour: 7.5YR 6/3 brown. Description: a groove, 1.00 cm wide and 0.30 cm deep, some parts in grey (7.5YR 5/1) colour, with remains of sediment (10YR 7/6 yellow).

L0512 (Fig. 13)**1.- Pottery****a) Egyptian pottery****Nile silt clay****Egyptian household ware**

No. 1: bowl (Fig. 13:1), Inv. No. C-6013 [004]

Uncoated	Nile B ₂	W ₂
----------	---------------------	----------------

Rim sherd (1/64); everted direct rim. Rd: 28.00 cm; Wd: 0.90 cm; H₁: 7.00 + x cm; made in parts; throwing lines outside and inside; smoothed on the wheel. Another, Rd: 30.00 cm 1/8

No. 2: large bowl (Fig. 13:1), Inv. No. C-6013 [006]

Uncoated	Nile C ₂	W ₂
----------	---------------------	----------------

Rim sherd (1/8); everted direct rim. Rd: 40.00 cm; Wd: 1.50 cm; H₁: 4.40 + x cm; string marks; throwing lines outside and inside; smoothed on the wheel.

No. 3: jar (Fig. 13:1), Inv. No. C-6013 [007]

Uncoated	Nile B ₂	W ₂
----------	---------------------	----------------

Rim sherd (3/32); slightly everted direct rim. Rd: 12.00 cm; Wd: 1.00 cm; H₁: 3.60 + x cm; throwing lines inside; smoothed on the wheel. Another, Rd: 12.00 cm 1/8.

No. 4: storage jar (Fig. 13:1), Inv. No. C-6013 [010]

Uncoated	Nile B ₂	W ₂
----------	---------------------	----------------

Rim sherd (1/32); vertical everted exterior and interior rim, flattened lip. Rd: 24.00 cm; Wd: 0.90 cm; H₁: 7.70 + x cm; throwing lines inside; made in parts; smoothed on the wheel.

No. 5: storage jar (Fig. 13:2), Inv. No. C-6013 [009]

Uncoated	Nile B ₂	W ₂
----------	---------------------	----------------

Rim sherd (3/32); vertical articulated exterior rim, flattened lip. Rd: 24.00 cm; Wd: 0.80 cm; H₁: 7.30 + x cm; made in parts; throwing lines inside; smoothed on the wheel.

No. 6: storage jar, Inv. No. C-6013 [008]

Uncoated	Nile B ₂	W ₂ + Ha ₂
----------	---------------------	----------------------------------

Body and handle fragment. Md: ca. 25.00 cm; Hd: 3.10 x 3.00 cm; throwing lines inside; finger marks on the handle surface; smoothed.

No. 7: storage jar, Inv. No. C-6013 [003]

Uncoated	Nile B ₂	Ha ₂
----------	---------------------	-----------------

Handle fragment. Hd: 2.90 x 2.20 cm; smoothed. Another, Hd: 3.50 x 3.00 cm.

Pottery with special functions**No. 8: lid**, Inv. No. C-6013 [002]Uncoated Nile B₂ W₂Rim sherd (3/32). Rd: 24.00 cm; Wd: 0.70 cm; H₁: 1.20 + x cm; throwing lines outside and inside; smoothed on the wheel; smoked inside.**No. 9: spinning bowl** (Fig. 13:2), Inv. No. C-6013 [001]Uncoated Nile C₁ W₂Body sherd (reconstructed shape). Md: ca. 22.00 cm; Wd: 1.00 cm; H₁: 6.00 + x cm; a hole on the body opened before firing; throwing lines inside; string marks; smoothed on the wheel.**No. 10: tray** (Fig. 13:2), Inv. No. C-6013 [014]Uncoated Nile C₂c. Ha₁

Fragmentary; D: 50.00 cm; uneven.

Egyptian marl**Household ware****No. 11: amphora**, Inv. No. C-6013 [015]Uncoated Marl F + ochre W₂ + Ha₂

Body and handle fragment. Md: 22.00 + x cm; Hd: 2.50 x 2.60 cm; throwing lines inside; finger marks on the handle surface; smoothed.

b) North Sinai/South Palestine pottery**Household ware****No. 12: amphora**, Inv. No. C-6013 [016]. II.TG 10, body sherd.**II.- Finds****Object of unknown use****No. 13: fragments (2) of an object**, Inv. No. F0772A. Bronze. 1) 0.78 x 0.94 x 0.36 cm; 2) 0.87 x 0.86 x 0.33 cm. *Find No. 001.***L0519 (Fig. 14)****I.- Pottery****a) Egyptian pottery****Nile silt clay****Egyptian household ware****No. 1: cooking pot**, Inv. No. C-6031 [001]Uncoated Nile B₂ W₂ W

Base fragment; rounded. Md: ca. 12.00 cm; throwing lines inside; smoothed on the wheel; smoked on the base, outside.

No. 2: jar (Fig. 14), Inv. No. P1259A (Drawing No. 0530)RS Nile B₂ W₂ --- ox. 2Rim sherd; articulated exterior rim. Rd: 5.00 cm 3/32; Wd: 0.40 cm; H₁: 1.00 + x cm. Surface colour: 10R 5/6 red slip. Break: 2.5Y 6/4 light yellowish brown. Technical details: throwing lines inside. Surface treatment: smoothed on the wheel. *Find No. 022.***No. 3: storage jar** (Fig. 14), Inv. No. P1160A (Drawing No. 0936)Uncoated Nile B₂ W₂ --- ox. 2

Rim and body fragment; articulated exterior rim. Rd: 20.00 cm 3/32; Wd: 1.60 cm; H₁: 28.00 + x cm. Surface colour: 2.5YR 5/6 red. Break: 2.5YR 3/1 dark reddish grey core; 2.5YR 5/6 red oxidation zones. Technical details: made in parts; throwing lines inside. Surface treatment: smoothed on the wheel. *Find No. 022.*

No. 4: storage jar (Fig. 14), Inv. No. C-6031 [003]

Uncoated	Nile B ₂	W ₂
----------	---------------------	----------------

Rim sherd (5/32); vertical articulated exterior rim, rounded lip. Rd: 25.00 cm; Wd: 1.70 cm; H₁: 11.00 + x cm made in parts; throwing lines inside; smoothed on the wheel.

Pottery with special functions

No. 5: bakery tray (Fig. 14), Inv. No. C-6031 [002]

Uncoated	Nile B ₂	W ₁	Ha
----------	---------------------	----------------	----

Complete, fragmentary. Rd: 16.00 cm 1/32; Bd: 14.00 cm 1/4; H₁: 3.80 cm. VI: 421; smoothed.

L0522 (Fig. 15)

1.- Pottery

a) Egyptian pottery

Nile silt clay

Egyptian household ware

No. 1: jar, Inv. No. C-6033 [003]

Uncoated	Nile B ₂	base finished on the wheel
----------	---------------------	----------------------------

Base fragment; pointed base; smoothed on the wheel.

No. 2: storage jar (Fig. 15), Inv. No. C-6033 [002]

Uncoated	Nile B ₂	W ₂
----------	---------------------	----------------

Rim sherd (1/8); exterior lip. Rd: 28.00 cm; Wd: 1.00 cm; H₁: 3.20 + x cm; smoothed on the wheel.

No. 3: tray (Fig. 15), Inv. No. C-6033 [001]

Uncoated	Nile C ₂	W ₁
----------	---------------------	----------------

Complete, fragmentary. D: 50.00 cm (1/16); H₁: 6.10 cm; uneven.

L0551 (Fig. 16)

1.- Pottery

a) Egyptian pottery

Nile silt clay

Household ware

No. 1: bowl, Inv. No. C-6012 [030]

Uncoated	Nile C ₁	W ₂
----------	---------------------	----------------

Rim sherd; ledge rim. Rd: 12.00 cm 3/21; throwing lines outside and inside; smoothed on the wheel; eroded.

No. 2: bowl (Fig. 16:1), Inv. No. C-6012 [002]

Uncoated	Nile B ₂	W ₂
----------	---------------------	----------------

Rim sherd (1/8); everted direct rim. Rd: 38.00 cm; Wd: 1.40 cm; H₁: 10.00 + x cm; throwing lines outside and inside; string marks; smoothed on the wheel.

No. 3: jar (Fig. 16:1), Inv. No. C-6012 [016]

Uncoated	Nile B ₂	W ₂
----------	---------------------	----------------

Rim sherd (1/8); vertical direct rim. Rd: 7.00 cm; Wd: 0.40 cm; H₁: 2.40 + x cm; throwing lines inside; smoothed on the wheel. Others, Rd: 12.00 cm, Rd: 10.00 m 3/32.

No. 4: jar, Inv. No. C-6012 [022]

Uncoated	Nile B ₂	W ₂	[base finished on the wheel]
----------	---------------------	----------------	------------------------------

Body sherd near the base; [pointed base]. Throwing lines inside, and outside near the base; smoothed on the wheel.

No. 5: storage jar (Fig. 16:1), Inv. No. C-6012 [010]

Uncoated	Nile B ₂	W ₂
----------	---------------------	----------------

Rim sherd (1/8); inverted articulated exterior rim, folded lip. Rd: 25.00 cm; Wd: 1.00 cm; H₁: 5.20 + x cm; made in parts; throwing lines inside; string marks; smoothed on the wheel.

No. 6: storage jar (Fig. 16:2), Inv. No. C-6012 [009]

Uncoated	Nile B ₂	W ₂
----------	---------------------	----------------

Rim sherd (3/32); slightly inverted articulated exterior rim, rolled lip. Rd: 24.00 cm; Wd: 1.00 cm; H₁: 6.90 + x cm; made in parts; throwing lines inside; string marks; smoothed on the wheel.

No. 7: storage jar, Inv. No. C-6012 [011]

Uncoated	Nile B ₂ c.	W ₂
----------	------------------------	----------------

Rim sherd (1/8); inverted articulated exterior and interior rim, rounded lip. Rd: 20.00 cm; Wd: 0.80 cm; H₁: 10.00 + x cm; made in parts; throwing lines inside; smoothed on the wheel.

No. 8: storage jar, Inv. No. C-6012 [027]

Uncoated	Nile B ₂	W ₂
----------	---------------------	----------------

Rim sherd (1/8). Rd: 24.00 cm; eroded.

No. 9: storage jar, Inv. No. C-6012 [006]

Uncoated	Nile B ₂	Ha ₂
----------	---------------------	-----------------

Handle fragment. Hd: 2.70 x 2.60 cm; smoothed. Others, Hd: 3.60 x 2.90 cm; Hd: 2.60 x 2.40 cm.

Pottery with special functions**No. 10: lid (Fig. 16:2), Inv. No. C-6012 [005]**

Uncoated	Nile B ₂	W ₂
----------	---------------------	----------------

Rim fragment (1/8). Rd: 28.00 cm; Wd: 1.20 cm; H₁: 7.00 + x cm; throwing lines outside and inside; smoothed on the wheel; smoked and eroded inside. Others: Rd: 20-28 cm, 0.22 lids.

No. 11: bakery tray (Fig. 16:2), Inv. No. C-6012 [003]

Uncoated	Nile C ₁ /E ₁	W ₁	Ha
----------	-------------------------------------	----------------	----

Complete, fragmentary. Rd: 26.00 cm; Bd: 25.00 cm; H₁: 5.70 cm. VI: 456; fingerprints on the base; smoothed.

No. 12: "pigeon pot", Inv. No. C-6012 [023]

Uncoated	Nile B ₂	W ₂
----------	---------------------	----------------

Body sherd near the base.

No. 13: cover of an oven?, Inv. No. C-6012 [004]

Uncoated	Nile C ₂ coarse	W ₁
----------	----------------------------	----------------

Fragment; D: ca. 50.00 cm; uneven.

No. 14: tray, Inv. No. C-6012 [019]

Uncoated	Nile C ₂	W ₁
----------	---------------------	----------------

Fragment.

Egyptian marls

Household ware

No. 15: amphora, Inv. No. C-6012 [020], Marl A₄, body sherds.

No. 16: amphora, Inv. No. C-6012 [007]

Uncoated	Marl F	Ha ₂
----------	--------	-----------------

Handle fragment. Hd: 3.1 x 2.5 cm; smoothed.

No. 17: amphora (Fig. 16:2), Inv. No. C-6012 [017]

Uncoated	Marl F	W ₂
----------	--------	----------------

Shoulder fragment; “torpedo” type. Md: ca. 26.0 cm; Wd: 0.80 cm; H₁: 8.30 + x cm; throwing lines outside and inside; smoothed on the wheel.

No. 17bis: amphora, Inv. No. C-6012 [026], Marl F, body sherd.

b) North Sinai/South Palestine pottery

Household ware

No. 18: amphora, Inv. No. C-6012 [024], II.TG 10, body sherd.

c) Imported household ware

Levantine household ware

No. 19: amphora, Inv. No. C-6012 [023], IV.TG 18, body sherd.

No. 20: amphora, Inv. No. C-6012 [018]

Uncoated	IV.TG 09	W ₂ + Ha ₂
----------	----------	----------------------------------

Body and handle fragment. Md: ca. 24.00 cm; Hd: 3.00 x 1.60 cm; throwing lines outside and inside; smoothed.

II.- Finds

Architectural feature

No. 21: door stopper (Fig. 16:3), Inv. No. F1102A (before Inv. No. F0939B. Drawing No. 0930). Fragmentary; limestone. Weight: 584.00 gr. 8.20 x 9.60 x 5.60 cm. Primary form: flake. Manufacture technique: flaking. Characteristics: large flake rounded by flaking. *Find No. 003*.

L1001 (Fig. 17)

I.- Pottery

a) Egyptian pottery

Nile silty clay

Household ware

No. 1: bowl (Fig. 17:1), Inv. No. C-6000 [020]

Uncoated	Nile C ₁	W ₂
----------	---------------------	----------------

Rim sherd (3/32); slightly vertical direct rim. Rd: 28.00 cm; Wd: 1.50 cm; H_1 : 7.50 + x cm; throwing lines inside; made in parts; smoothed on the wheel.

No. 2: bowl (Fig. 17:1), Inv. No. C-6000 [044]

Uncoated	Nile C ₂	W ₂
----------	---------------------	----------------

Rim sherd (3/16); everted direct rim. Rd: 23.00 cm; Wd: 1.20 cm; H_1 : 4.00 + x cm; smoothed on the wheel.

No. 3: bowl (Fig. 17:1), Inv. No. C-6000 [028]

Uncoated	Nile C ₁	W ₂
----------	---------------------	----------------

Rim sherd (1/16); everted articulated exterior rim. Rd: 24.00 cm; Wd: 0.60 cm; H_1 : 2.30 + x cm; throwing lines; smoothed on the wheel.

No. 4: bowl (Fig. 17:1), Inv. No. C-6000 [046]

Uncoated	Nile B ₂	W ₂
----------	---------------------	----------------

Rim sherd (3/32); everted articulated exterior rim. Rd: 24.00 cm; Wd: 0.60 cm; H_1 : 3.50 + x cm; smoothed on the wheel; eroded inside.

No. 5: large bowl (Fig. 17:1), Inv. No. C-6000 [022]

Uncoated	Nile B ₂	W ₂
----------	---------------------	----------------

Rim sherd (1/32); undulated exterior walls; everted direct rim. Rd: 24.00 cm; Wd: 1.50 cm; H_1 : 4.50 cm; throwing lines; made in parts; string marks on the exterior; smoothed on the wheel. Others, Rd: 24.00 cm 3/64, Rd: 34.00 cm 3/64, Rd: 38.00 cm 5/64. Nile C₁, Rd: 28.00 cm 1/8, Rd: 34.00 cm 3/32, Rd: 40.00 cm 1/16.

No. 6: large bowl (Fig. 17:1), Inv. No. C-6000 [018]

Uncoated	Nile B ₂ /C ₁	W ₂
----------	-------------------------------------	----------------

Rim sherd (1/32); everted direct rim. Rd: 45.00 cm; Wd: 1.50 cm; H_1 : 4.50 + x cm; throwing lines inside; made in parts; smoothed on the wheel.

No. 7: bowl (Fig. 17:1), Inv. No. C-6000 [029]

Uncoated	Nile B ₂	W ₂
----------	---------------------	----------------

Rim sherd (1/8); slightly everted direct rim. Rd: 20.00 cm; Wd: 0.70 cm; H_1 : 3.00 + x cm; smoothed on the wheel. Smoked inside (used as a lid?).

No. 8: bowl (Fig. 17:1), Inv. No. C-6000 [003]

Uncoated	Nile B ₂	W ₂	base finished on the wheel
----------	---------------------	----------------	----------------------------

Base (1/1); pointed base. Md: 13.0 + x cm; Wd: 0.70 cm; H_1 : 5.00 + x cm; rilling lines outside on the base; smoothed on the wheel. Observations: eroded inside.

No. 9: jar (Fig. 17:2), Inv. No. C-6000 [047]

Uncoated	Nile B ₂	W ₂
----------	---------------------	----------------

Rim sherd (7/32); inverted direct rim. Rd: 11.09 cm; Wd: 0.50 cm; H_1 : 3.50 + x cm; throwing lines inside; made in parts; a groove below the rim; smoothed on the wheel.

No. 10: jar (Fig. 17:2), Inv. No. C-6000 [048]

Uncoated	Nile B ₂	W ₂
----------	---------------------	----------------

Rim sherd (1/8); inverted articulated exterior lip, folded lip. Rd: 14.00 cm; Wd: 0.70 cm; H_1 : 3.50 + x cm; throwing lines inside; made in parts; smoothed on the wheel.

No. 11: jar (Fig. 17:2), Inv. No. C-6000 [012]

Uncoated	Nile B ₂	W ₂
----------	---------------------	----------------

Rim sherd (5/32); vertical direct rim. Rd: 16.00 cm; Wd: 0.50 cm; H₁: 4.00 + x cm; throwing lines inside; made in parts; smoothed on the wheel. Rd: 12.00 cm 1/16.

No. 12: jar (Fig. 17:2), Inv. No. C-6000 [014]

Uncoated	Nile B ₂	W ₂
----------	---------------------	----------------

Rim sherd (1/8); vertical slightly articulated interior rim, round lip. Rd: 10.00 cm; Wd: 0.50 cm; H₁: 5.50 + x cm; throwing lines inside; smoothed on the wheel.

No. 13: jar (Fig. 17:2), Inv. No. C-6000 [011]

Uncoated	Nile B ₂	W ₂
----------	---------------------	----------------

Rim sherd (3/16); vertical direct rim. Rd: 10.00 cm; Wd: 0.50 cm; H₁: 6.50 + x cm; throwing lines inside; smoothed on the wheel; eroded inside. Another, Rd: 12.00 cm 1/16.

No. 14: jar (Fig. 17:2), Inv. No. C-6000 [051]

Uncoated	Nile B ₂	W ₂
----------	---------------------	----------------

Rim sherd (3/32); direct rim. Rd: 14.00 cm; Wd: 0.60 cm; H₁: 2.80 + x cm; throwing lines inside; smoothed on the wheel; eroded inside.

No. 15: jar (Fig. 17:2), Inv. No. C-6000 [013]

Uncoated	Nile B ₂	W ₂
----------	---------------------	----------------

Rim sherd (7/32); slightly everted direct rim. Rd: 11.00 cm; Wd: 0.60 cm; H₁: 3.50 + x cm; throwing lines inside; made in parts; smoothed on the wheel. Another, Rd: 10.00 cm 5/32.

No. 16: jar (Fig. 17:2), Inv. No. C-6000 [010]

Uncoated	Nile B ₂	W ₂
----------	---------------------	----------------

Rim sherd (1/16); slightly everted articulated interior and exterior rim. Rd: 16.0 cm; Wd: 1.00 cm; H₁: 3.50 + x cm; made in parts; throwing lines inside; smoothed on the wheel. Another Rd 10.0 cm: 0.25 jar, eroded.

No. 17: jar (Fig. 17:3), Inv. No. C-6000 [001]

Uncoated	Nile B ₂	W ₂	base finished on the wheel
----------	---------------------	----------------	----------------------------

Base (1/1); ring base (R₃). Md: 9.00 + x cm; Bd: 11.00 cm; Wd: 1.00 cm; H₁: 5.00 + x cm; smoothed on the wheel; eroded inside. Others, Bd: 8.00 cm 5/32, Bd 11.00 cm 1/32.

No. 18: jar (Fig. 17:3), Inv. No. C-6000 [004]

Uncoated	Nile B ₂	W ₂	base finished on the wheel
----------	---------------------	----------------	----------------------------

Body sherd near the base; [pointed base]. Md: 12.00 + x cm; Wd: 1.00 cm; H₁: 5.00 + x cm; made in parts; fingerprints inside; throwing lines on the exterior; smoothed on the wheel. Others, Md: 5.00 + x cm; Wd: 0.50 cm; H₁: 2.00 + x cm; Md: 10.00 + x cm; Wd: 0.50 cm; H₁: 4.00 + x cm; base twisted with the fingers; Md: 6.00 + x cm; Wd: 0.30 cm; H₁: 3.00 + x cm.

No. 19: storage jar (Fig. 17:3), Inv. No. C-6000 [036]

Uncoated	Nile B ₂	W ₂
----------	---------------------	----------------

Rim sherd (1/4) and swelling of the handle; inverted articulated exterior rim; folded lip. Rd: 37.00 cm; Wd: 1.00 cm; H₁: 8.00 + x cm; throwing lines inside; made in parts; smoothed on the wheel. Others, Rd: 24.00 cm 1/8, Rd: 26.00 cm 1/4, Rd: 26.00 cm 1/8.

No. 20: storage jar (Fig. 17:3), Inv. No. C-6000 [037]

Uncoated	Nile B ₂	W ₂
----------	---------------------	----------------

Rim sherd (1/8); slightly inverted articulated exterior rim, round lip. Rd: 22.00 cm; Wd: 0.70 cm; H₁: 8.00 + x cm; throwing lines inside; made in parts; smoothed on the wheel.

No. 21: storage jar (Fig. 17:4), Inv. No. C-6000 [030]

Uncoated	Nile B ₂	W ₂
----------	---------------------	----------------

Rim sherd (1/16); vertical articulated exterior rim. Rd: 24.0 cm; Wd: 1.20 cm; H₁: 6.50 + x cm; throwing lines inside; string marks on the exterior below the rim; smoothed on the wheel.

No. 22: storage jar (Fig. 17:4), Inv. No. C-6000 [032]

Uncoated	Nile B ₂	W ₂
----------	---------------------	----------------

Rim and handle fragment (7/32); vertical articulated interior and exterior rim, flattened lip. Rd: 23.00 cm; Wd: 1.00 cm; H₁: 13.50 + x cm; Hd: 3.00 x 2.80 cm; throwing lines inside; made in parts; finger marks on the handle surface; smoothed on the wheel. Others, 20.00-24.00 cm: 15 storage jars.

No. 23: storage jar? (Fig. 17:4), Inv. No. C-6000 [052]

Uncoated	Nile C ₁	W ₂
----------	---------------------	----------------

Rim sherd (3/32); vertical direct rim. Rd: 20.00 cm; Wd: 1.50 cm; H₁: 3.50 + x cm; a groove inside; made in parts; smoothed on the wheel.

No. 24: storage jar (Fig. 17:4), Inv. No. C-6000 [034]

Uncoated	Nile B ₂	W ₂
----------	---------------------	----------------

Rim sherd (3/16); slightly everted articulated exterior rim. Rd: 21.00 cm; Wd: 0.70 cm; H₁: 7.50 x cm; throwing lines inside; made in parts; smoothed on the wheel. Others, 22.00-30.00 cm: 0.50 storage jar.

No. 25: storage jar (Fig. 17:4), Inv. No. C-6000 [031]

Uncoated	Nile B ₂	W ₂
----------	---------------------	----------------

Rim sherd (1/32) everted articulated exterior rim, folded lip. Rd: 20.00 cm; Wd: 1.00 cm; H₁: 5.00 + x cm; throwing lines inside; smoothed on the wheel.

No. 26: storage jar (Fig. 17:4), Inv. No. C-6000 [040]

Uncoated	Nile B ₂	W ₂
----------	---------------------	----------------

Rim sherd (3/16); everted articulated exterior rim, flattened lip. Rd: 20.00 cm; Wd: 1.00 cm; H₁: 5.50 + x cm; throwing lines inside; made in parts; smoothed on the wheel.

No. 27: storage jar (Fig. 17:5), Inv. No. C-6000 [008]

Uncoated	Nile B ₂	W ₂
----------	---------------------	----------------

Rim sherd (3/16); everted articulated rim, compound rim. Rd: 20.00 cm; Wd: 0.70 cm; H₁: 7.00 + x cm; throwing lines inside; made in parts; smoothed on the wheel.

No. 28: storage jar (Fig. 17:5), Inv. No. C-6000 [017]

Uncoated	Nile B ₂	W ₂
----------	---------------------	----------------

Rim sherd (1/8); everted direct rim, flattened lip. Rd: 22.00 cm; Wd: 1.30 cm; H₁: 5.20 + x cm; throwing lines inside; made in parts; smoothed on the wheel.

No. 29: storage jar (or zir?) (Fig. 17:5), Inv. No. C-6000 [007]

Uncoated	Nile B ₂	W ₂
----------	---------------------	----------------

Rim sherd (1/4); everted articulated exterior rim. Rd: 17.00 cm; Wd: 1.30 cm; H₁: 9.00 + x cm; made in parts; fingerprints and scraping marks inside; smoothed on the wheel. Another,

Rd: 20.00 cm 3/32

No. 30: storage jar (Fig. 17:5), Inv. No. C-6000 [039]

Uncoated	Nile B ₂	Ha ₂
----------	---------------------	-----------------

Handle fragment. Hd: 5.50 x 6.00 cm; finger marks on the surface; smoothed. Others, Hd: 3.0 x 2.5 cm; Hd: 4.0 x 3.0 cm.

No. 31: amphora (Fig. 17:5), Inv. No. C-6000 [005]

Uncoated	Nile clay	W ₂
----------	-----------	----------------

Rim and body sherd (5/32); globular shape; vertical direct rim. Rd: 12.00 cm; Wd: 0.70 cm; H₁: 3.00 + x cm; throwing lines inside; made in parts; smoothed on the wheel. Observations: burnt.

Pottery with special functions

No. 32: lid of an oven (Fig. 17:5), Inv. No. P1114A (Drawing No. 0634)

Uncoated	Nile C ₁	W ₂	W	ox.	2
----------	---------------------	----------------	---	-----	---

Incomplete, fragmentary. D: 22.80 cm ³/₄; H₁: 3.20 + x cm. Surface colour: 7.5YR 6/3 light brown. Break: 2.5YR 5/4 reddish brown. Technical details: throwing lines outside and inside. Surface treatment: smoothed on the wheel. Smoked inside.

No. 33: lid (Fig. 17:6), Inv. No. C-6000 [006]

Uncoated	Nile B ₂	W ₂
----------	---------------------	----------------

Rim sherd (7/32). Rd: 24.00 cm; Wd: 0.60 cm; H₁: 5.50 + x cm; throwing lines inside; smoothed on the wheel. Observations: smoked inside. Others, Rd: 20.00 cm 1/16, Rd: 32.00 cm 1/32.

No. 34: bakery tray (Fig. 17:6), Inv. No. C-6000 [027]

Uncoated	Nile C ₂	W ₁	Ha
----------	---------------------	----------------	----

Complete, fragmentary; everted direct rim. Rd: 32.00 cm; Bd: 30.00 cm; H₁: 4.60 cm; smoothed. Another, Rd: 18.00 cm and Bd: 16.0 0cm.

No. 35: "pigeon pot" (Fig. 17:6), Inv. No. C-6000 [009]

Uncoated	Nile B ₂	W ₂	W
----------	---------------------	----------------	---

Base fragment (1/4). Md: 11.50 + x cm; Bd: 6.00 cm; Wd: 1.00 cm; H₁: 7.50 + x cm; throwing lines inside; made in parts; smoothed on the wheel.

No. 36: "pigeon pot" (Fig. 17:6), Inv. No. C-6000 [016]

Uncoated	Nile B ₂	W ₂	W
----------	---------------------	----------------	---

Base fragment (1/8). Bd: 6.00 cm; Wd: 1.00 cm; H₁: 6.00 + x cm; made in parts; throwing lines inside; smoothed on the wheel. Others, Bd: 5.00 cm 5/32, Bd: 6.00 cm 1/4.

No. 37: tray (Fig. 17:7), Inv. No. P1119A (Drawing No. 0919)

Uncoated	Nile C ₂	Ha ₁	re.	2
----------	---------------------	-----------------	-----	---

Complete, fragmentary. D: ca. 50.0 cm; H₁: 5.50 cm. Surface colour: 5YR 5/3 reddish brown. Break: 5YR 3/1 very dark grey core; 5YR 5/3 reddish brown oxidation zones. Surface treatment: uneven. Observations: salt incrustated. Another, a fragment.

No. 38: tray (Fig. 17:7), Inv. No. P1118A (Drawing No. 0919)

Uncoated	Nile C ₂	W ₁	re.	2
----------	---------------------	----------------	-----	---

Complete, fragmentary. D: ca. 50.0 cm; H₁: 6.00 cm. VI: 833. Surface colour: 5YR 5/3 reddish brown. Break: 5YR 3/1 very dark grey core; 5YR 5/3 reddish brown oxidation

zones. Surface treatment: uneven.

Egyptian marls

Household ware

No. 39: amphora, Inv. No. C-6000 [049]

Uncoated	Marl A ₄	W ₂
----------	---------------------	----------------

Body fragment. Md: 24.0 cm; Wd: 0.40 cm; H₁: 4.20 + x cm; made in parts; ribbed surface; smoothed on the wheel.

No. 40: amphora, Inv. No. C-6000 [061]

Uncoated	Marl A ₄	W ₂
----------	---------------------	----------------

Base fragment, round. Md: 10.00 + x cm; Wd: 0.50 cm; H₁: 4.50 + x cm; made in parts; smoothed on the wheel.

No. 41: amphora (Fig. 17:7), Inv. No. C-6000 [053]

Uncoated	Marl F + limestone	W ₂
----------	--------------------	----------------

Shoulder fragment. Md: 28.00 cm; Wd: 0.70 cm; H₁: 5.00 + x cm; smoothed on the wheel.

No. 42: storage jar, Inv. No. C-6000 [060]

Uncoated	Marl F	Ha ₂
----------	--------	-----------------

Handle fragment. Hd: 3.09 x 1.89 cm; smoothed.

No. 43: amphora, Marl F + ochre, body sherd.

Body sherds, Nile B₂, Nile C₁-C₂: 337.00 dm²; Nile C₂ c.: 4.00 dm²; Marl A₄, Marl F.

b) North Sinai/South Palestine pottery

Household ware

No. 44: amphora, II.TG 10, body sherd.

c) Imported pottery

Levantine household ware

No. 45: amphora (Fig. 17:7), Inv. No. C-6000 [054]

Uncoated	IV.TG 18	W ₂ + Ha ₂
----------	----------	----------------------------------

Body fragment and handle. Md: ca. 23.00 cm; Hd: 2.50 x 2.00 cm; made in parts; smoothed.

No. 46: amphora, IV.TG 22, body sherds.

No. 47: amphora (Fig. 17:8), Inv. No. C-6000 [056]

Uncoated	IV.TG 23	W ₂ + Ha ₂
----------	----------	----------------------------------

Shoulder and handle. Md: 26.00 cm; Wd: 0.90 cm; H₁: 9.00 + x cm; Hd: 3.00 x 2.80 cm; smoothed.

No. 48: amphora, Inv. No. C-6000 [067]

Uncoated	IV.TG 23	Ha ₂
----------	----------	-----------------

Handle fragment; Hd: 4.20 x 2.80 cm; smoothed.

No. 49: amphora, IV.TG 23, body sherds: 23 dm².

No. 50: amphora, IV.TG 53, body sherd.

Phoenician household ware**No. 51: jar?** (Fig. 17:8), Inv. No. C-6000 [050]Uncoated | IV.TG 37 = IV.Phoen.03 | W₂Rim sherd. Rd: 6.00 cm; Wd: 0.70 cm; H₁: 4.50 x cm; smoothed on the wheel.***Cypriote household ware*****No. 52: amphora**, VI.TG 04, body sherds.**II.- Finds*****Suspended weight*****No. 53: loom weight** (Fig. 17:8), Inv. No. F1113A (Drawing No. C-6000 [024]).

Fragmentary (1/2 preserved) ; clay. 8.00 x 4.00 x 3.50 cm. Conical shape.

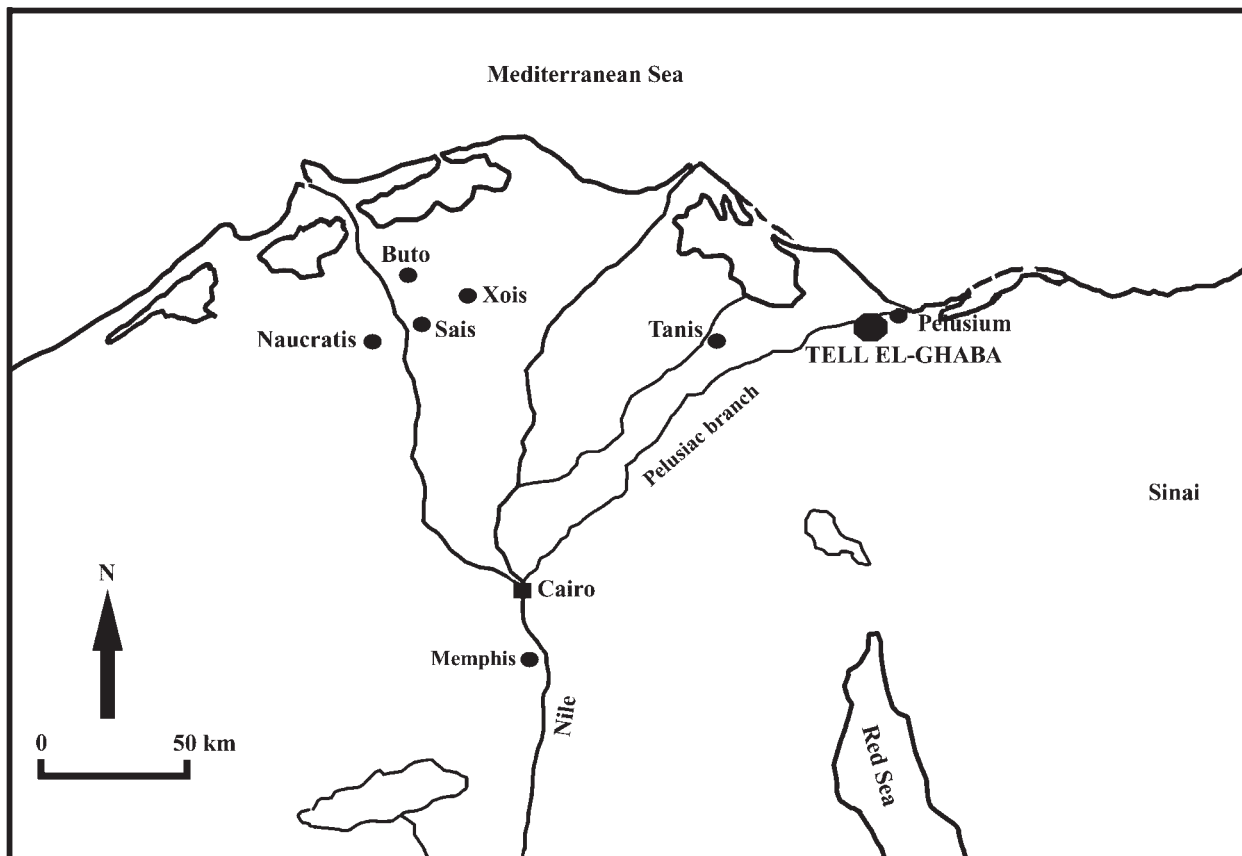
Personal objects**No. 54: bead**, Inv. No. F0670A. Fragmentary; faience; moulded. D: 0.63 cm; colour: 2.5Y 8/2 (pale yellow); cylindrical shape; perforation: 2.1 mm. *Find No. 025*.**No. 55: bead**, Inv. No. F0922A (Drawing No. 0926). Complete; shell (*Ciprea albina*). 1.40 x 1.10 x 0.30 cm. Function: female fertility amulet.

List of Figures and Plates (AREA VI) by Loci

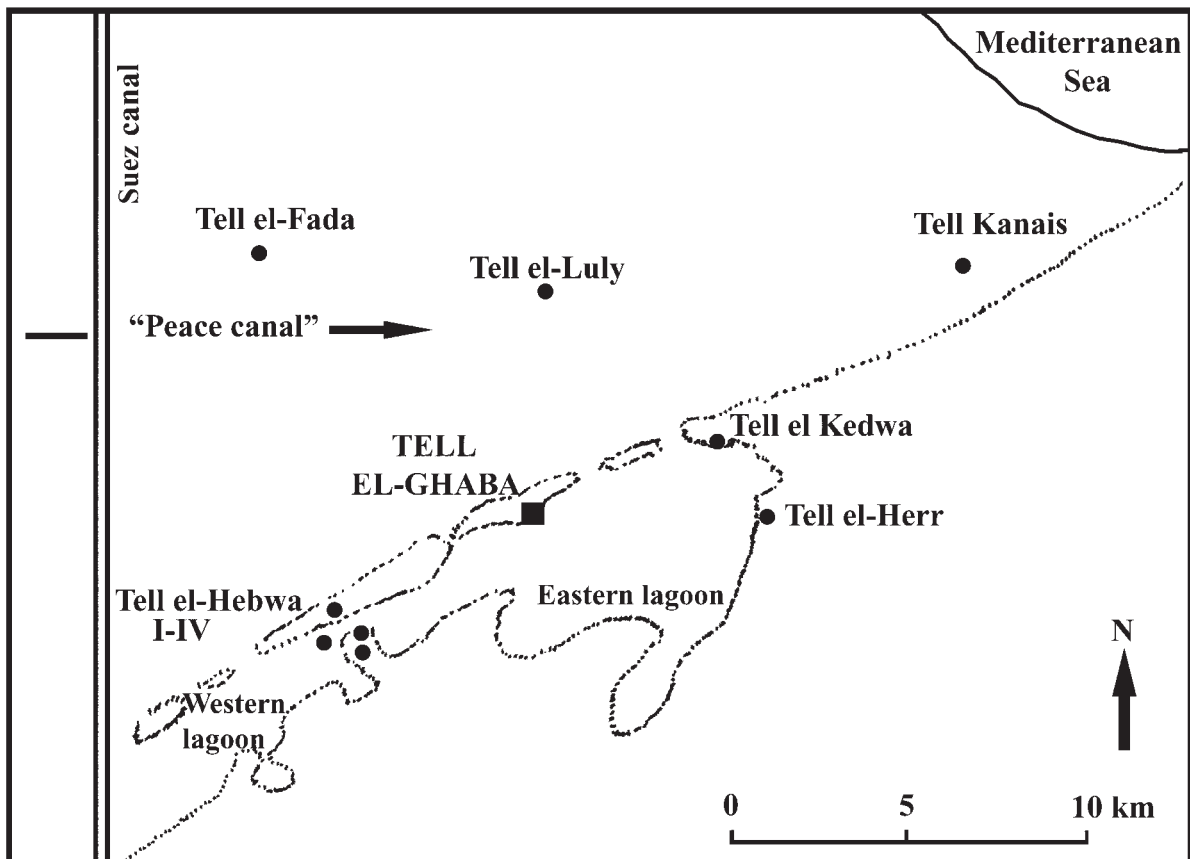
AREA VI		
LOCUS	FIGURE	PLATE
L0503	Fig. 09	Plate 1
L0507	Fig. 11	
L0508	Fig. 12	
L0511	Fig. 01	
L0512	Fig. 13	
L0516	Fig. 10	
L0517	Fig. 02	
L0518	Fig. 03	
L0519	Fig. 14	
L0522	Fig. 15	
L0546	Fig. 04	
L0547	Fig. 05	
L0551	Fig. 16	
L0587	Fig. 06	
L0589	Fig. 07	
L0591	Fig. 08	
L1001	Fig. 17	

List of Figures and Plates (Area VI)

AREA VI		
FIGURE	PLATE	LOCUS
Fig. 01		L0511
Fig. 02		L0517
Fig. 03		L0518
Fig. 04		L0546
Fig. 05		L0547
Fig. 06		L0587
Fig. 07		L0589
Fig. 08		L0591
Fig. 09	Plate 1	L0503
Fig. 10		L0516
Fig. 11		L0507
Fig. 12		L0508
Fig. 13		L0512
Fig. 14		L0519
Fig. 15		L0522
Fig. 16		L0551
Fig. 17		L1001



Egypt, the Nile Delta



The Eastern Delta. The Suez Canal-Pelusium area with archaeological sites

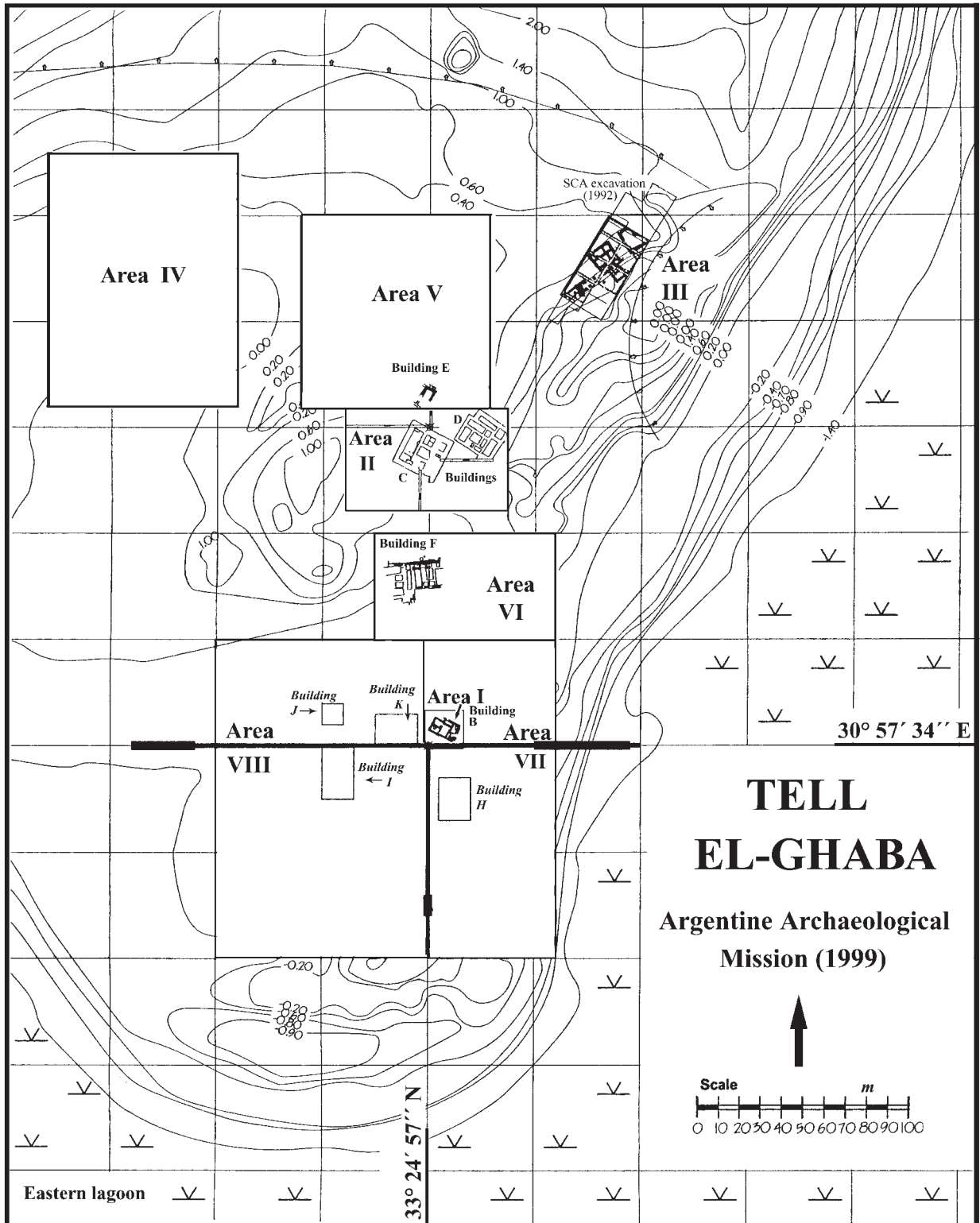


Plate I,1

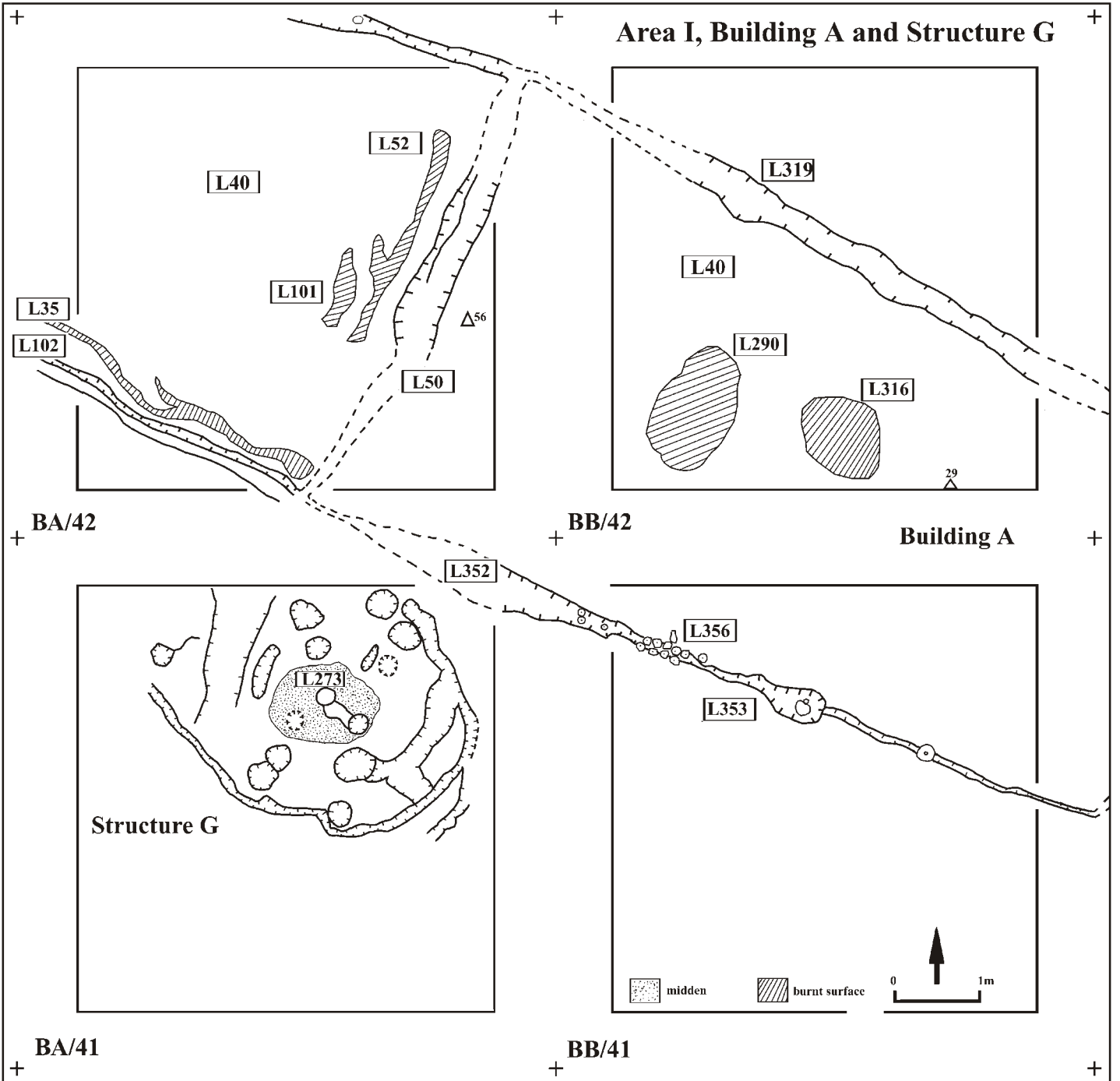


Plate I,2

Plan of Tell el-Ghaba showing the areas excavated and surveyed by the Argentine Archaeological Mission (1995-1999)

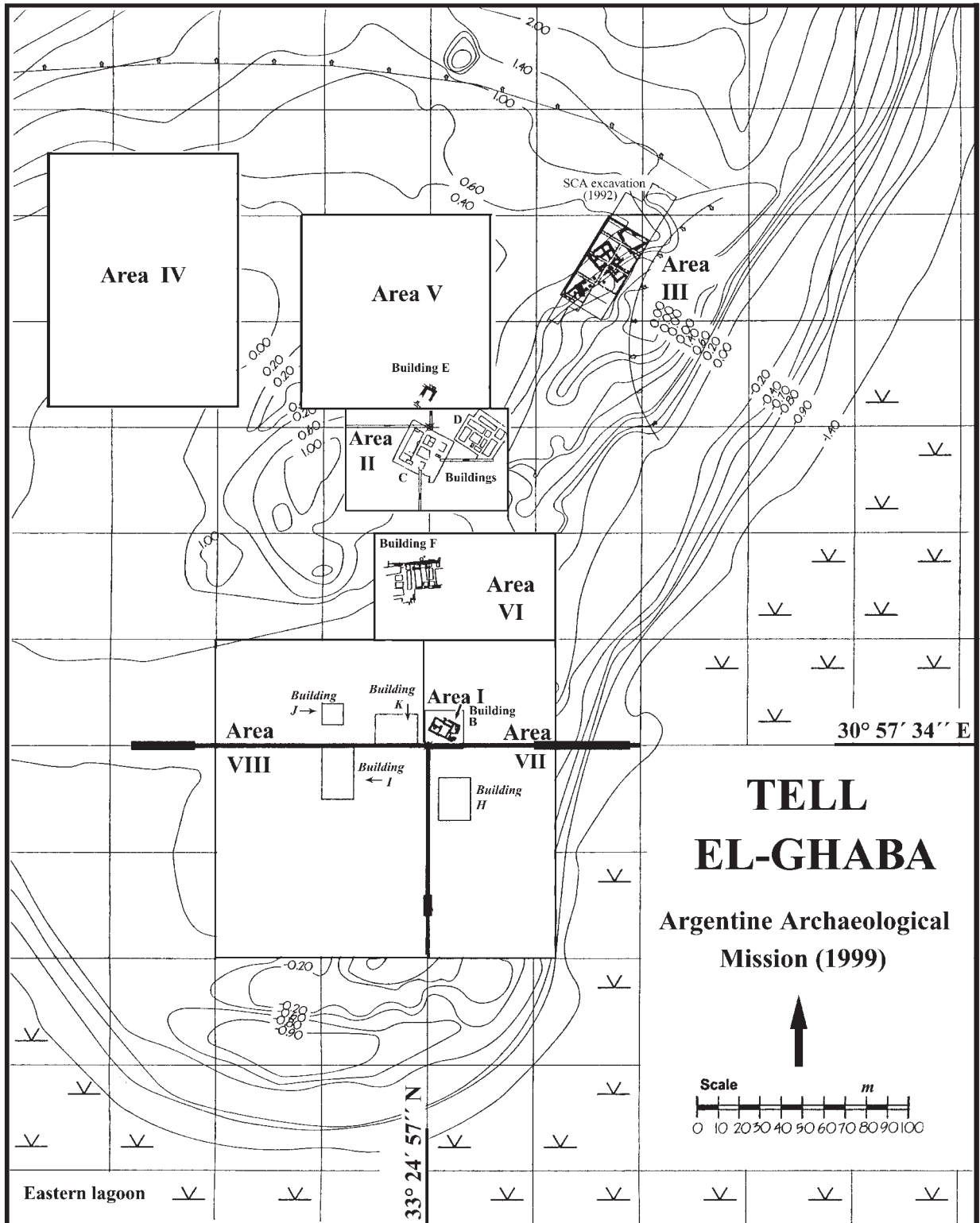


Area I, Building A and Structure G

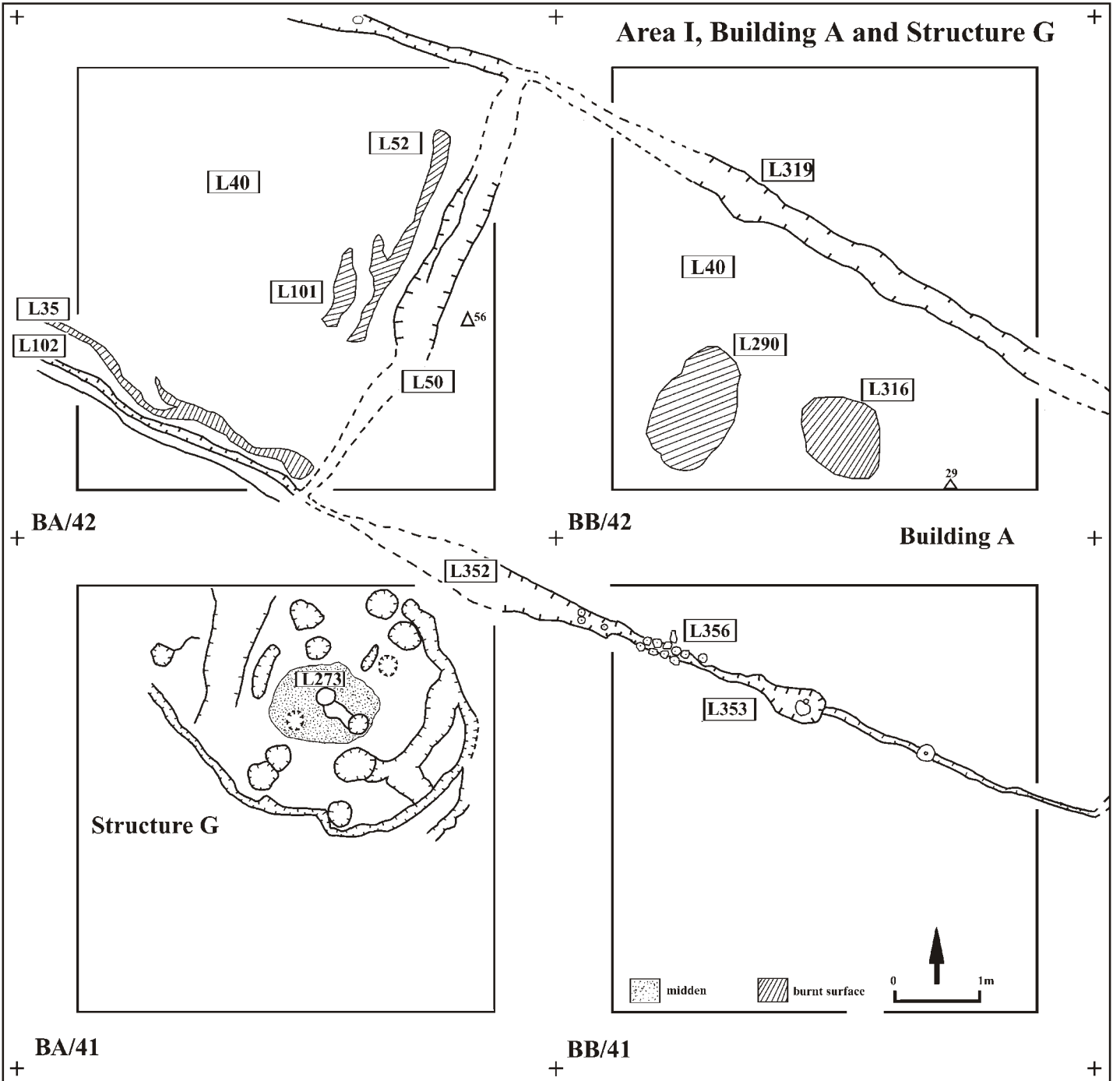


Plan II

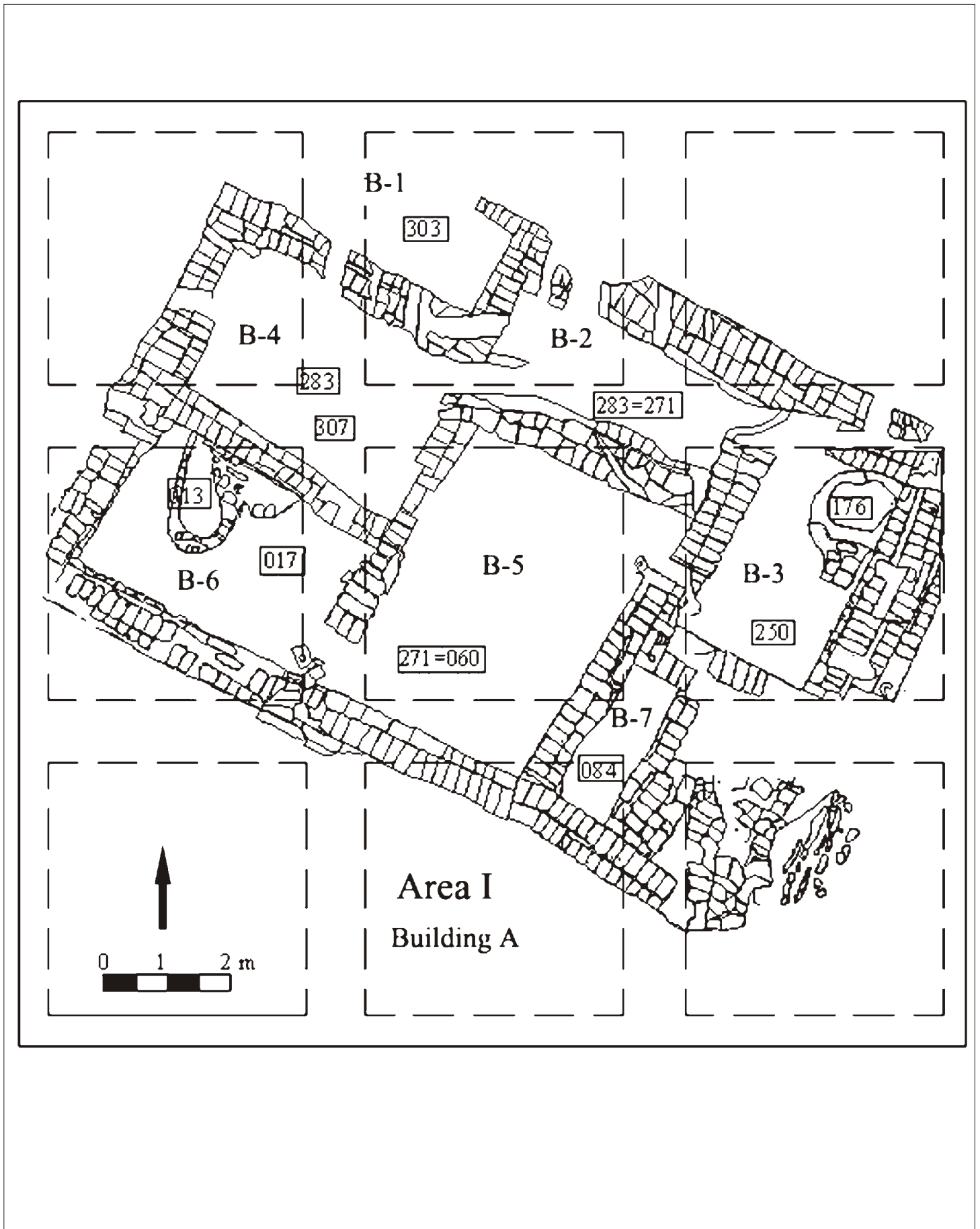
Plan of Tell el-Ghaba showing the areas excavated and surveyed by the Argentine Archaeological Mission (1995-1999)



Area I, Building A and Structure G

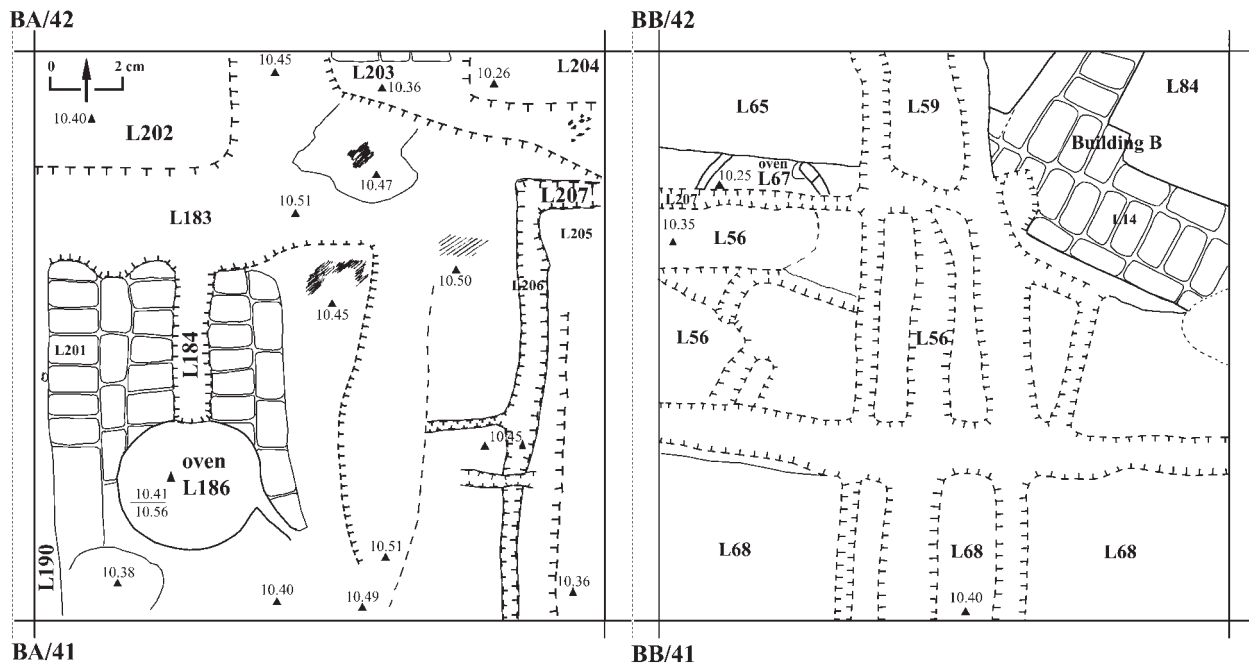


Plan II



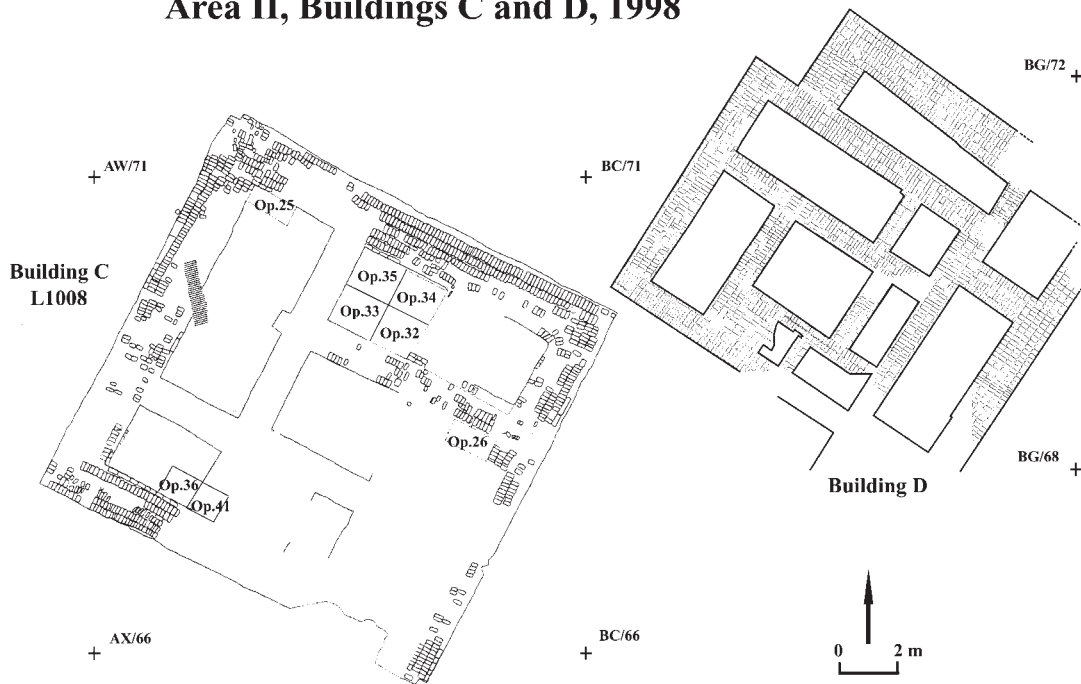
Plan III

Area I, Workshops



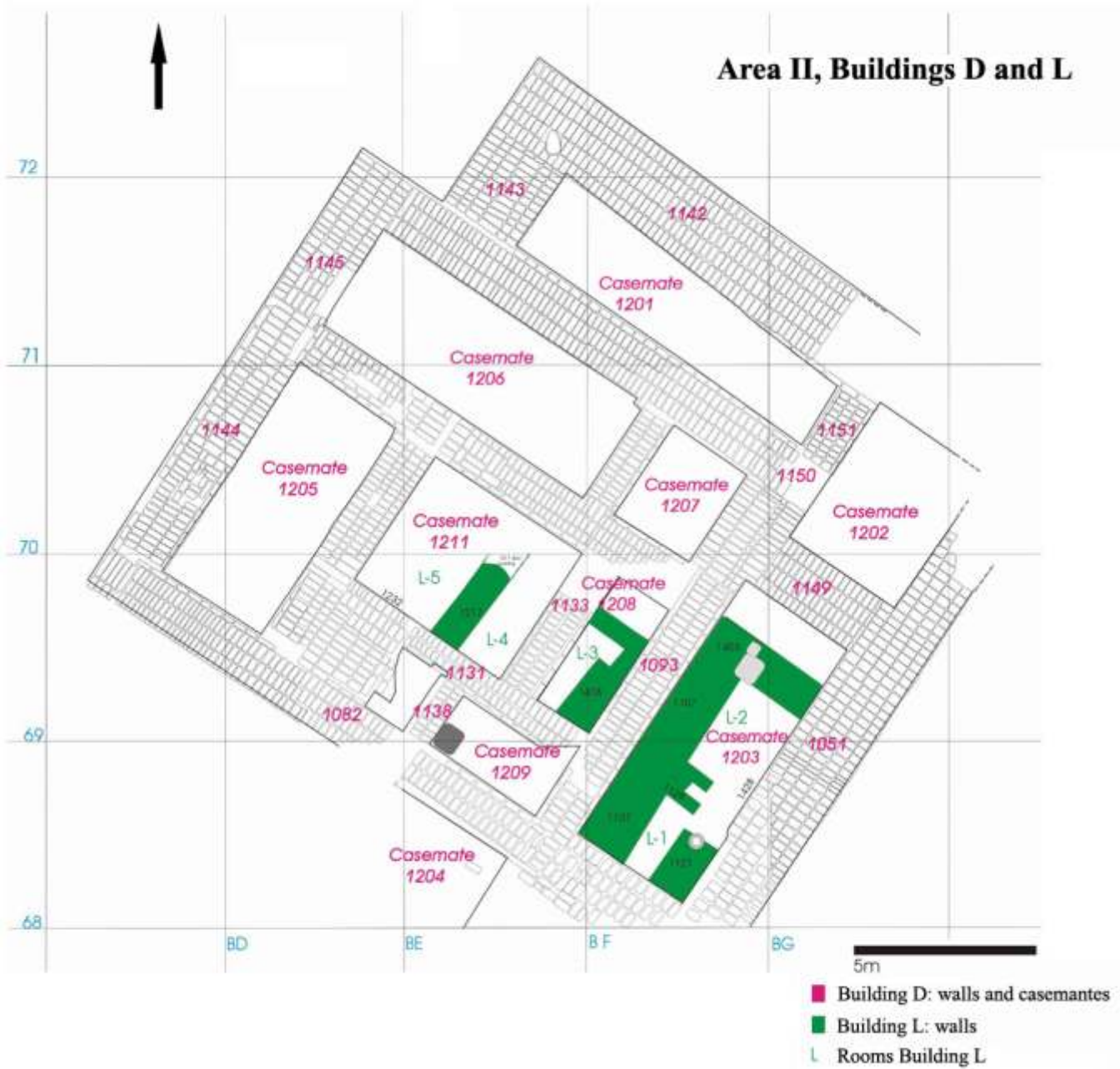
Plan IV

Area II, Buildings C and D, 1998

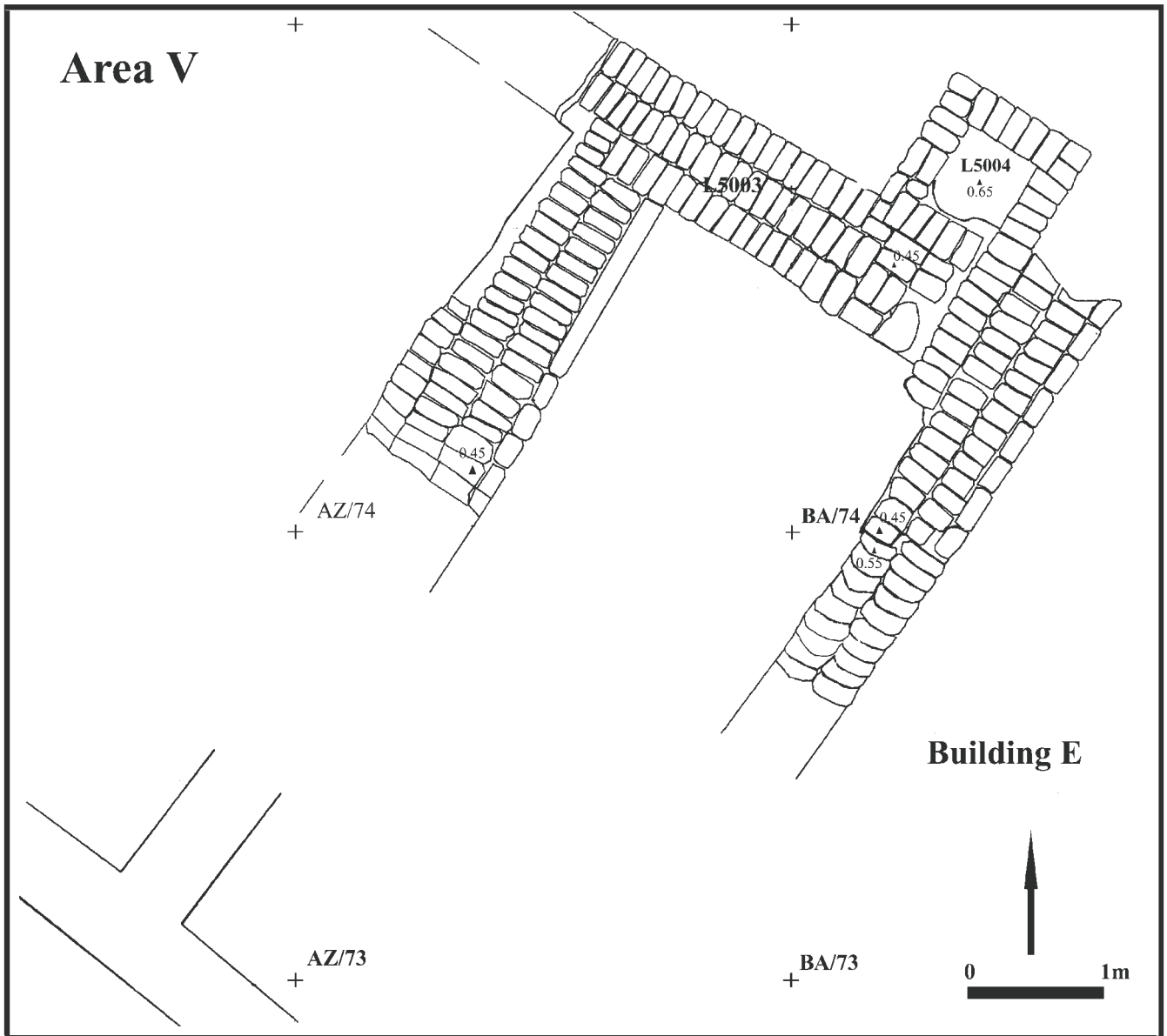


Plan V

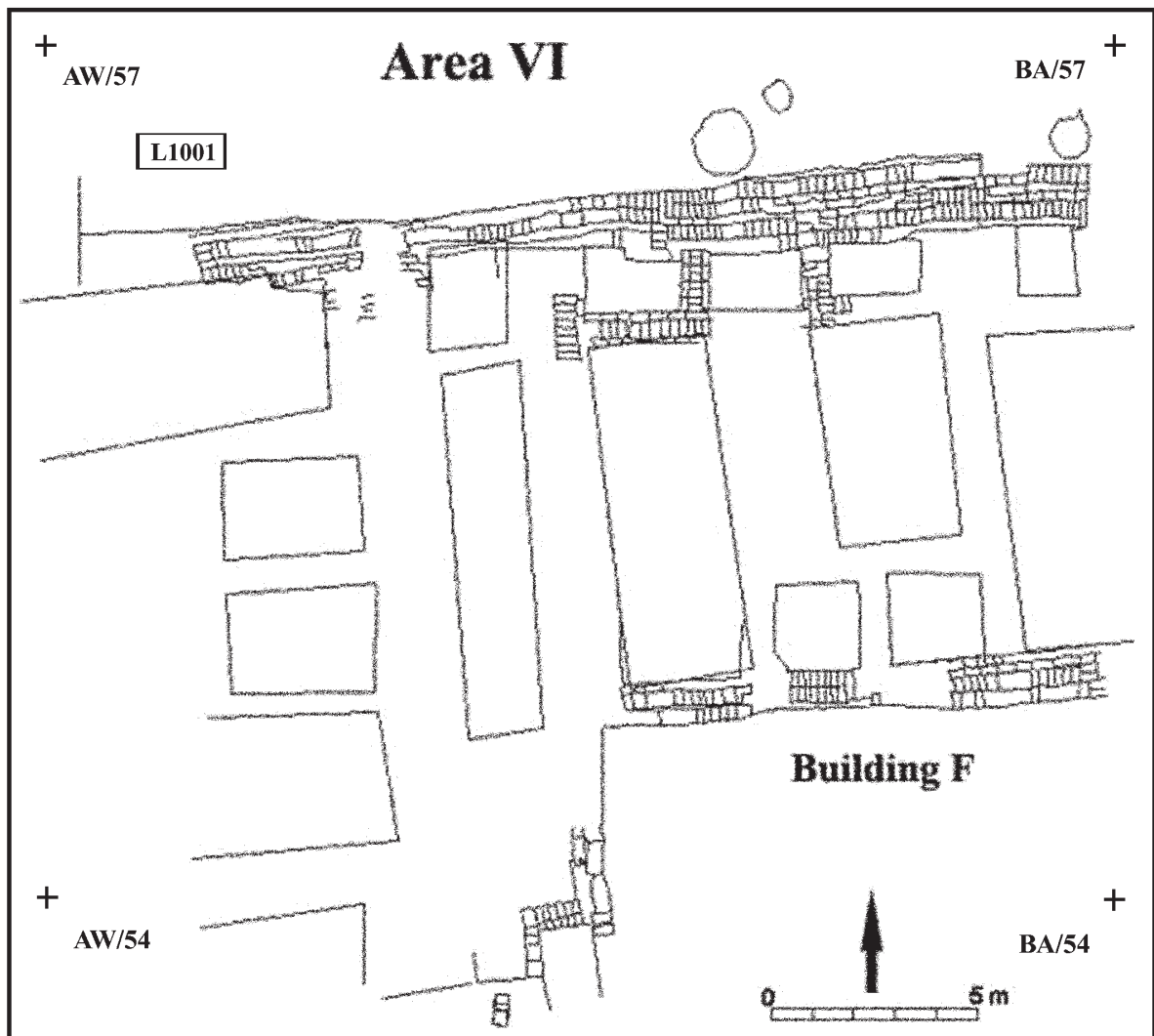
Area II, Buildings D and L

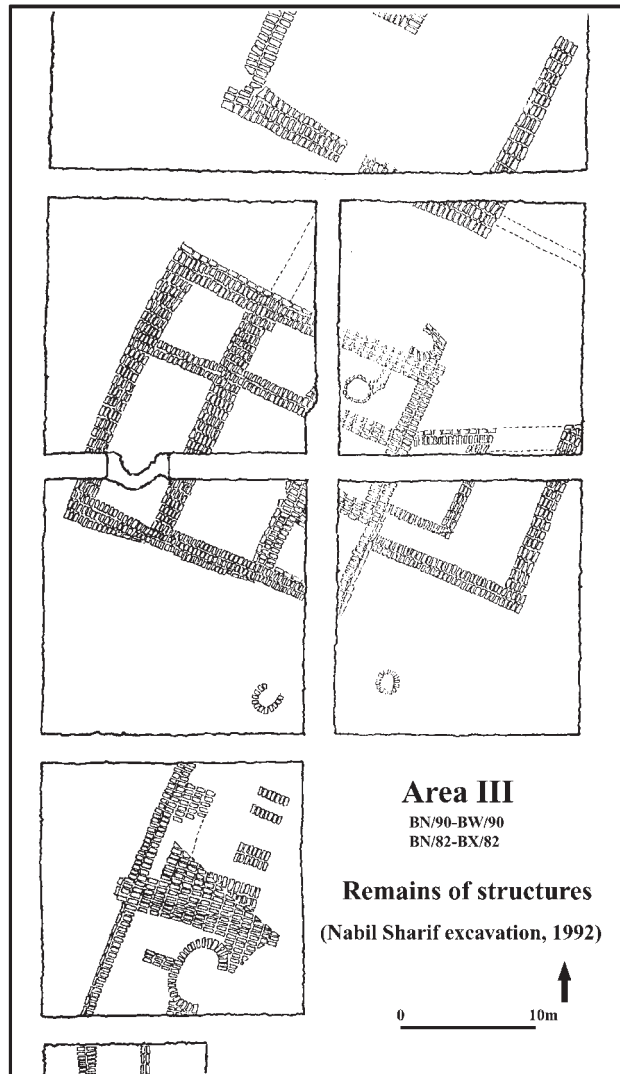


Plan VI

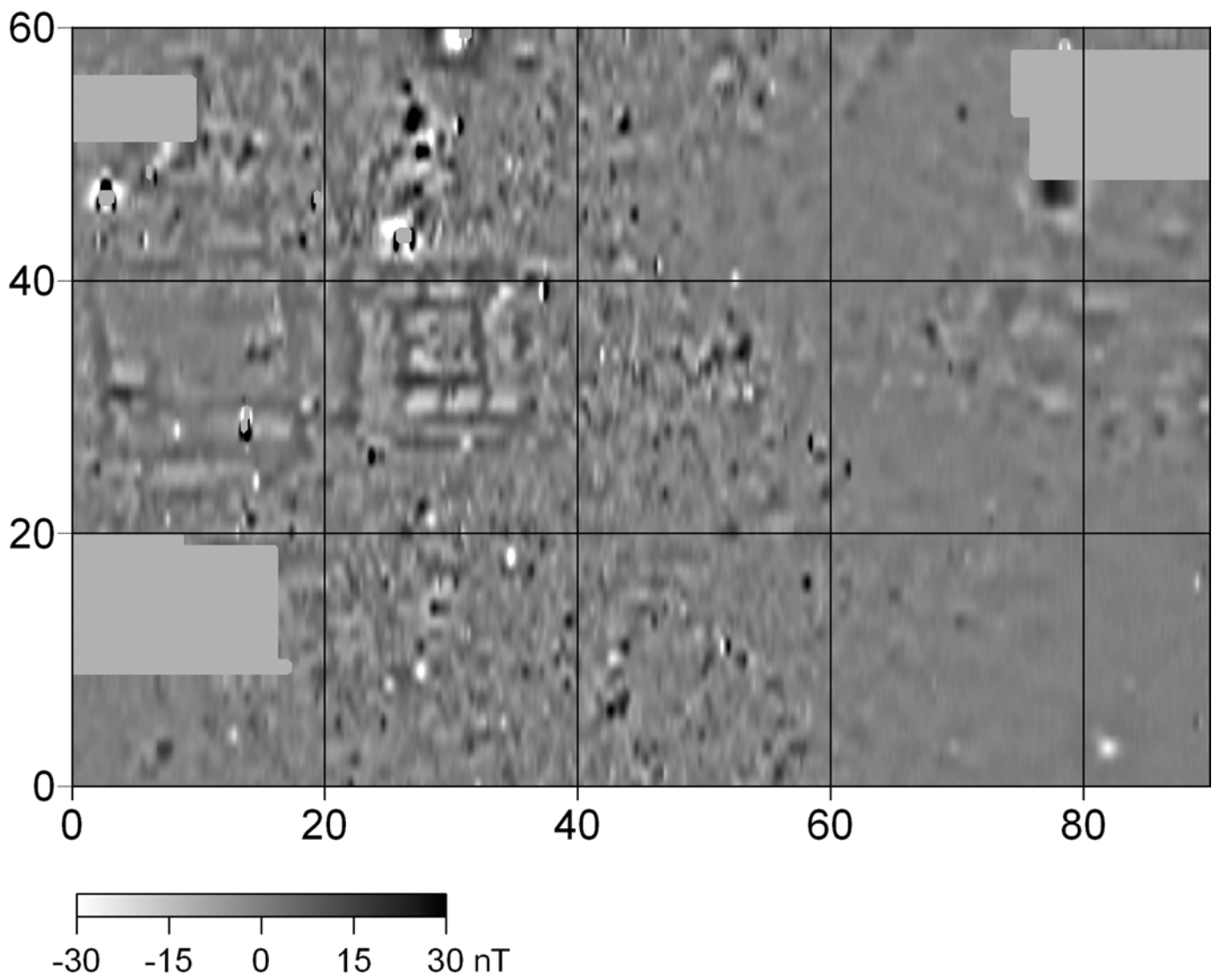


Plan VII

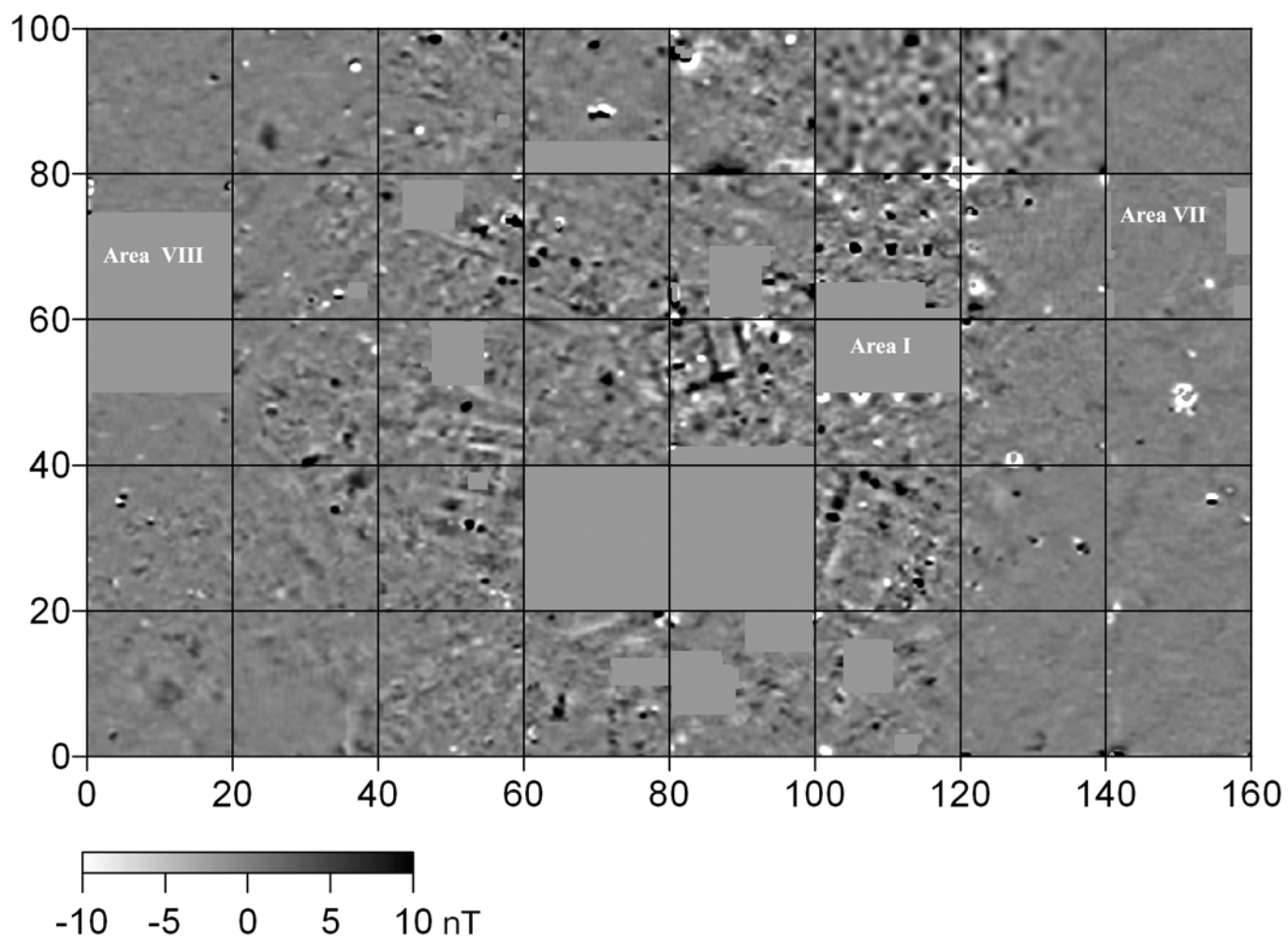




Geophysical survey of Tell el-Ghaba, Area VII (1998)



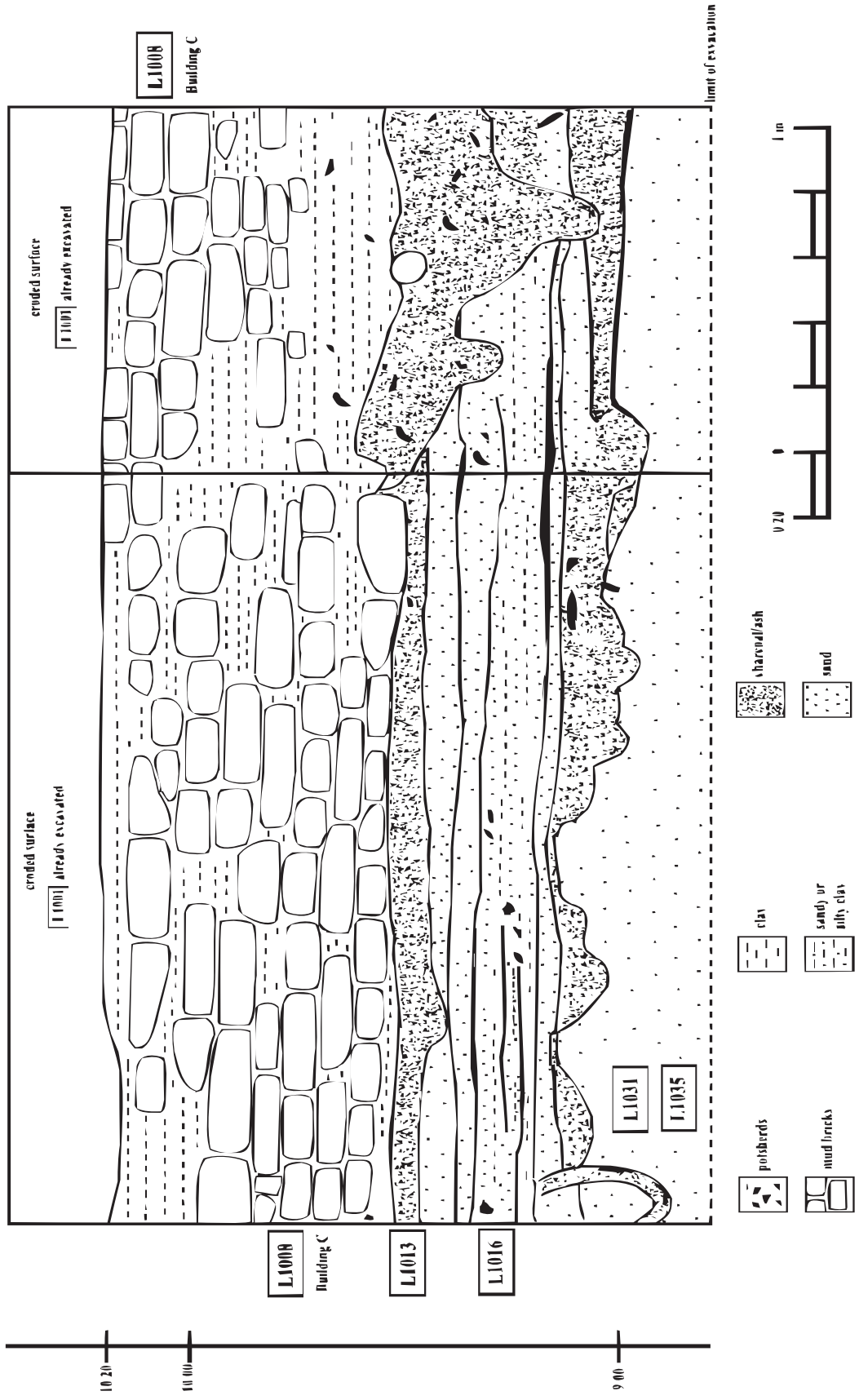
Geophysical survey of Tell el-Ghaba, Areas I, VII and VIII (1999)



Area II west, Operation 26

North section

East section



Area II west, Operation 26

South section

West section

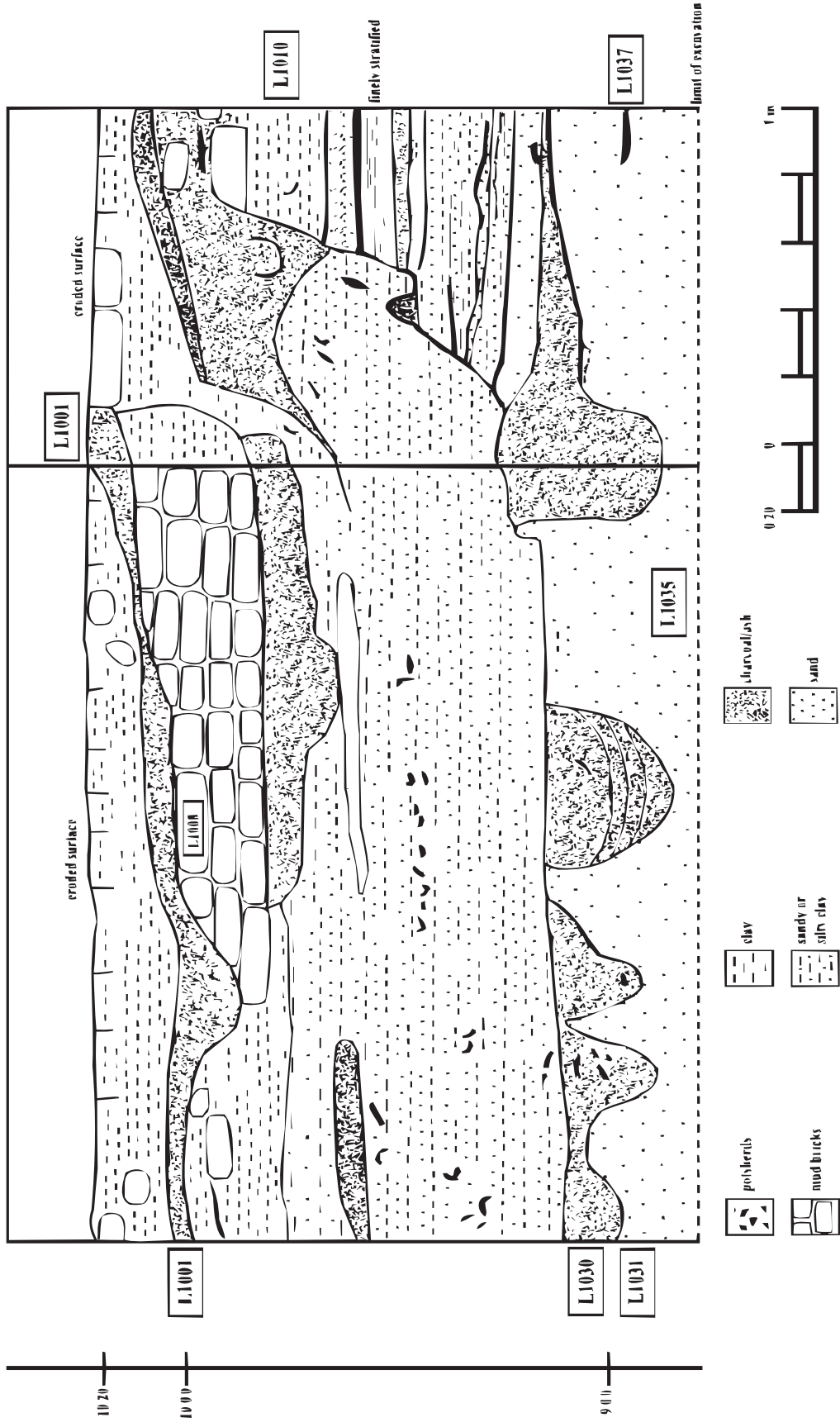




Plate XI

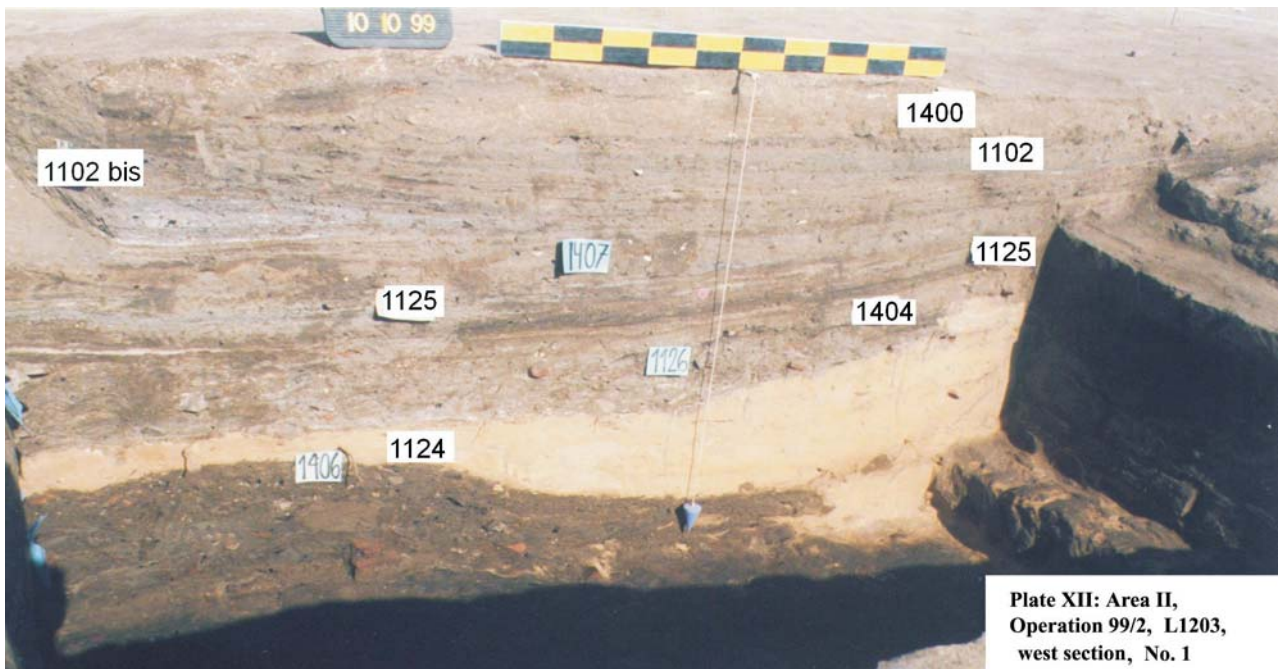


Plate XII: Area II,
Operation 99/2, L1203,
west section, No. 1

Plate XII



Plate XIII

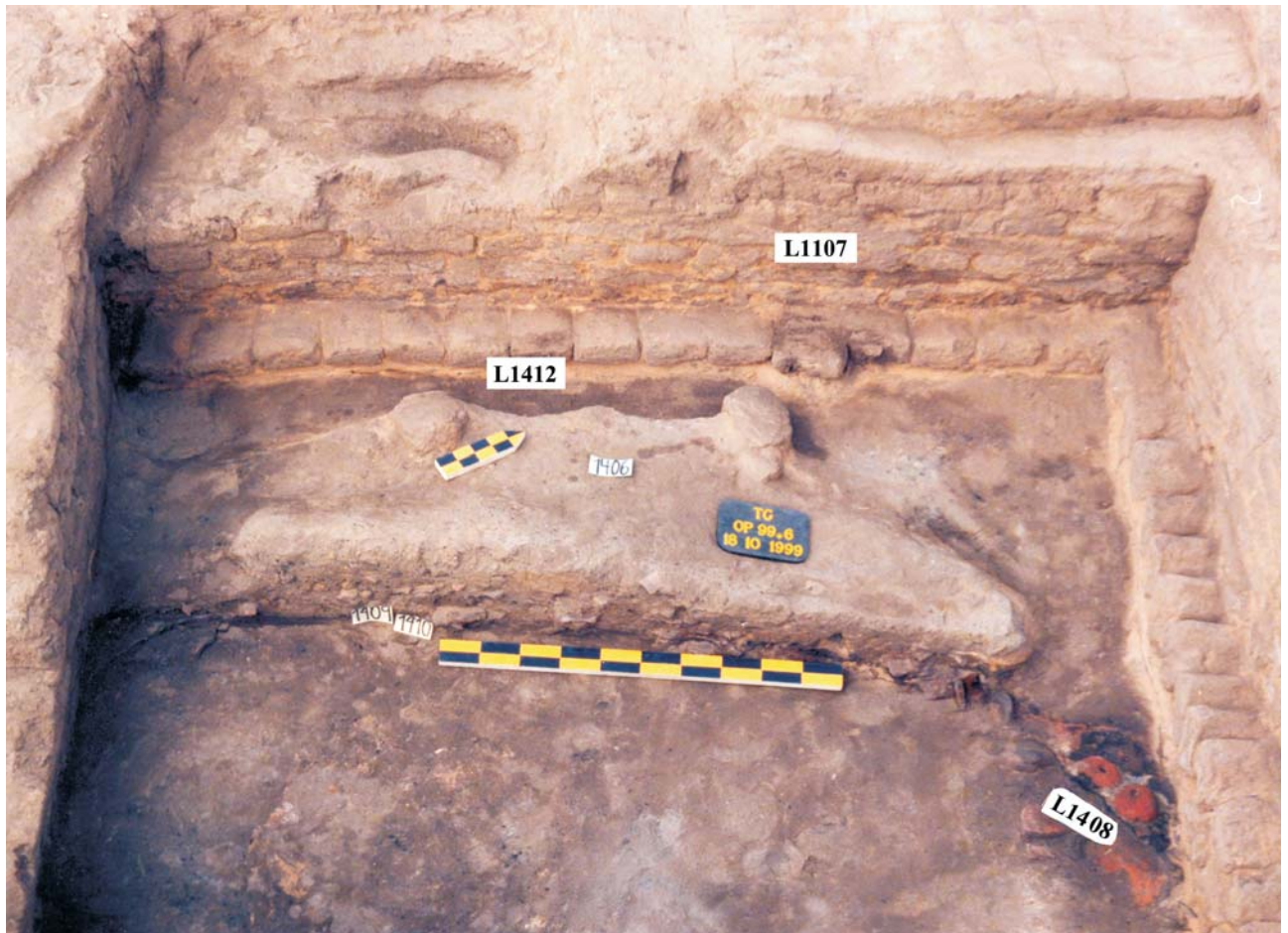


Plate X



Plate VI

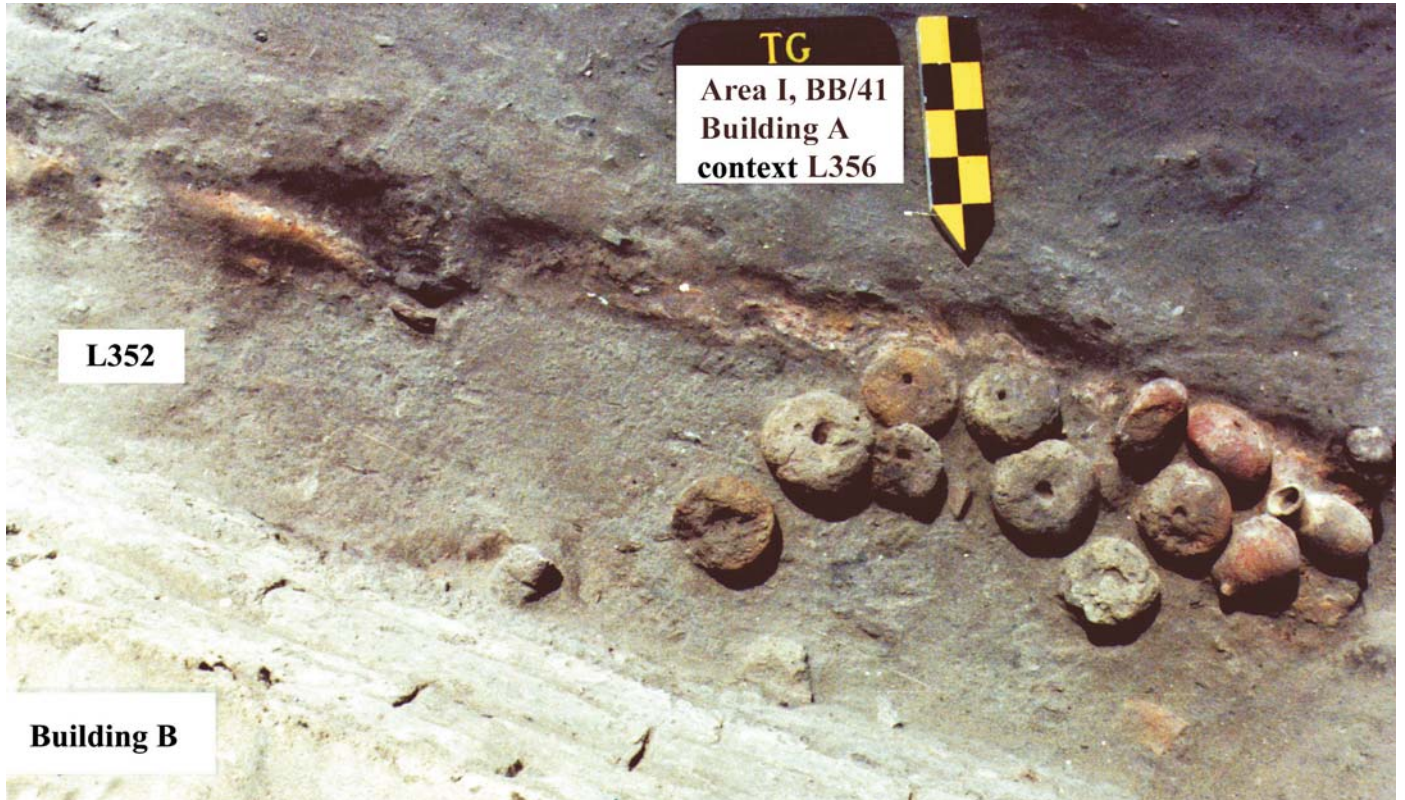


Plate VII



Plate I,1



Plate I,2



Plate II



Plate III



Plate IV

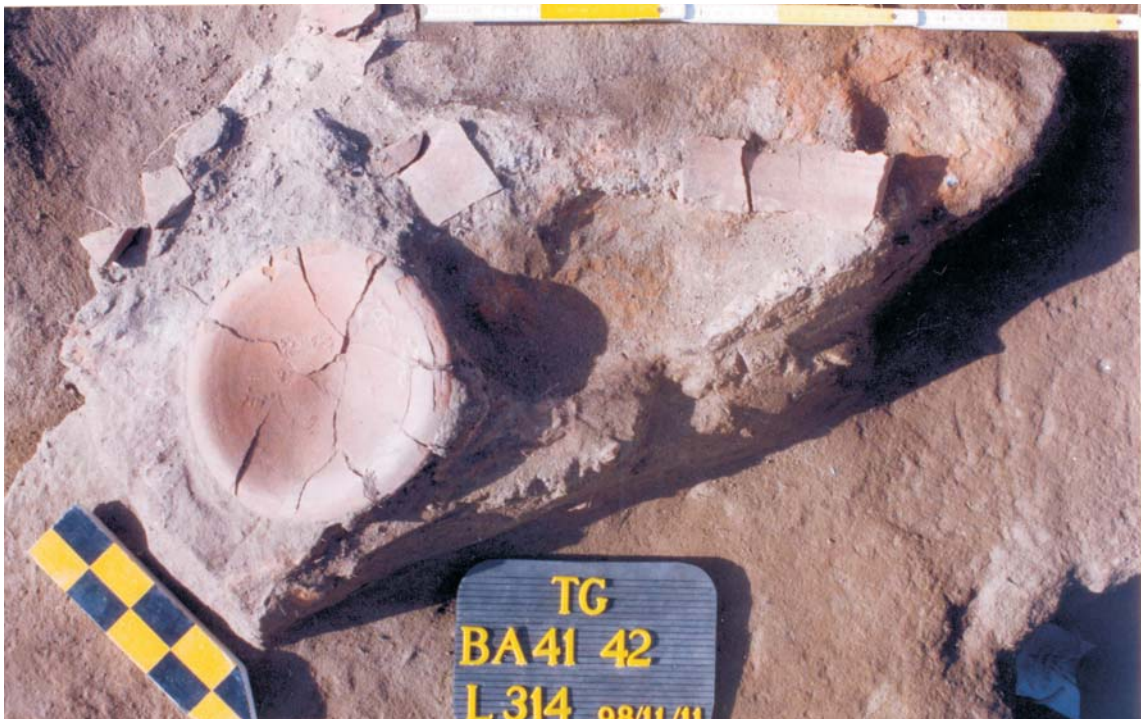


Plate V



Plate VI

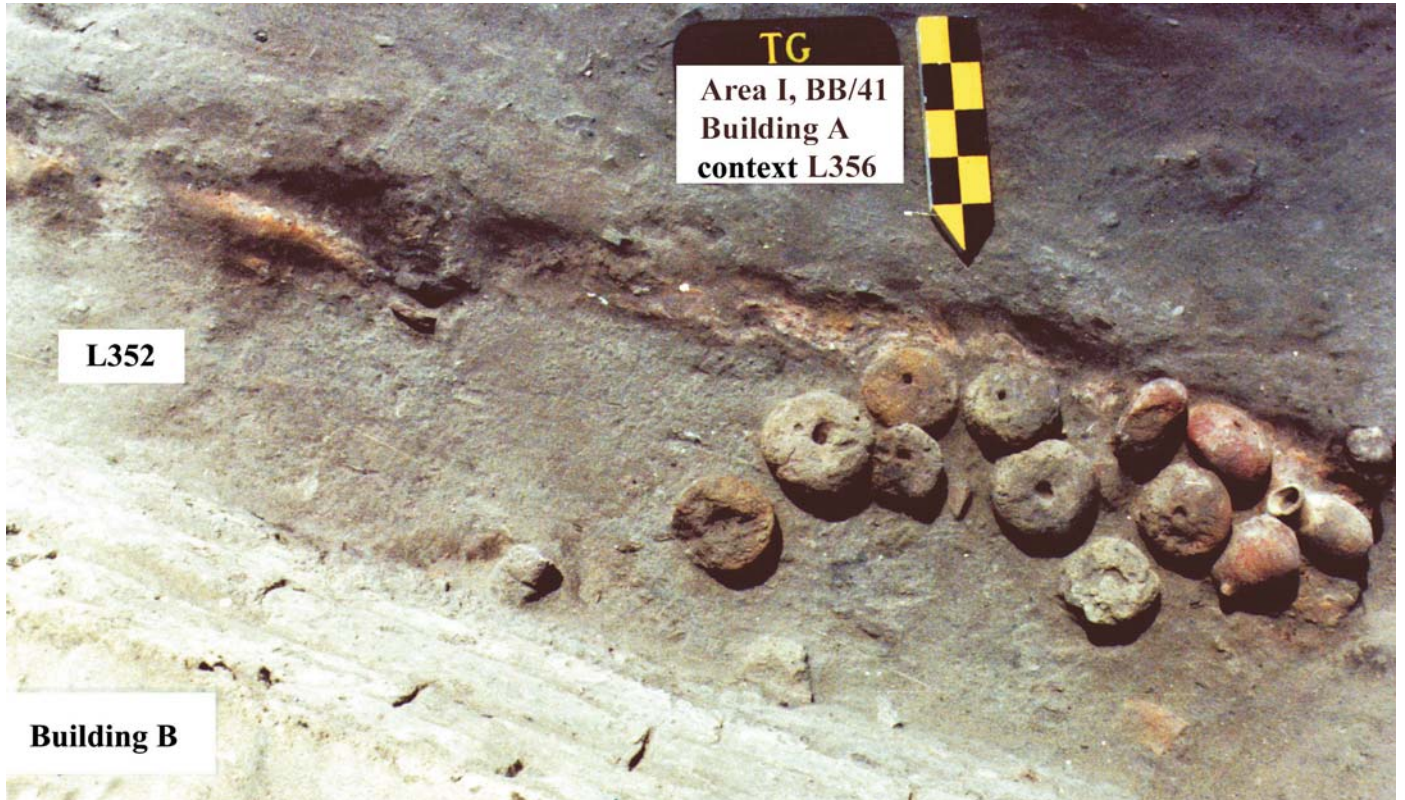


Plate VII



Plate VIII. Area I, BA/43, L0001, west section

Plate VIII



Plate IX

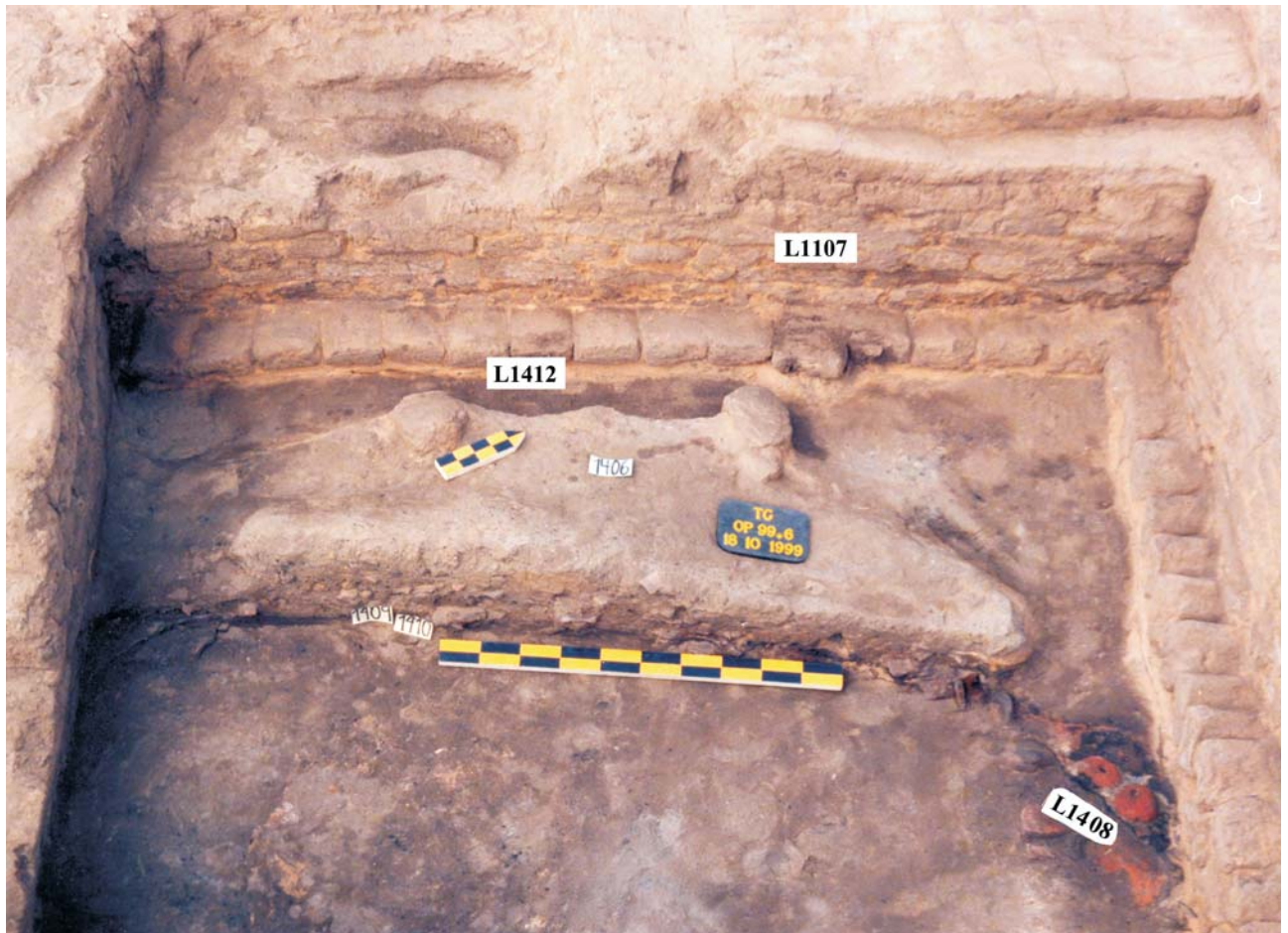


Plate X



Plate XI

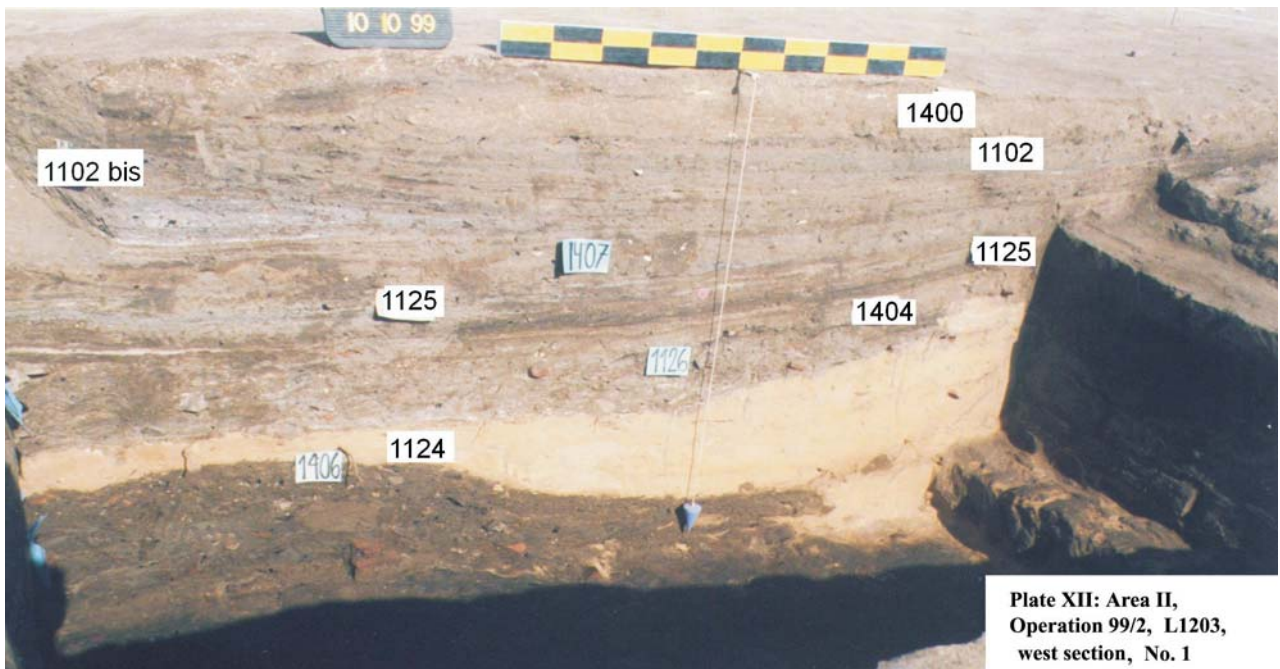


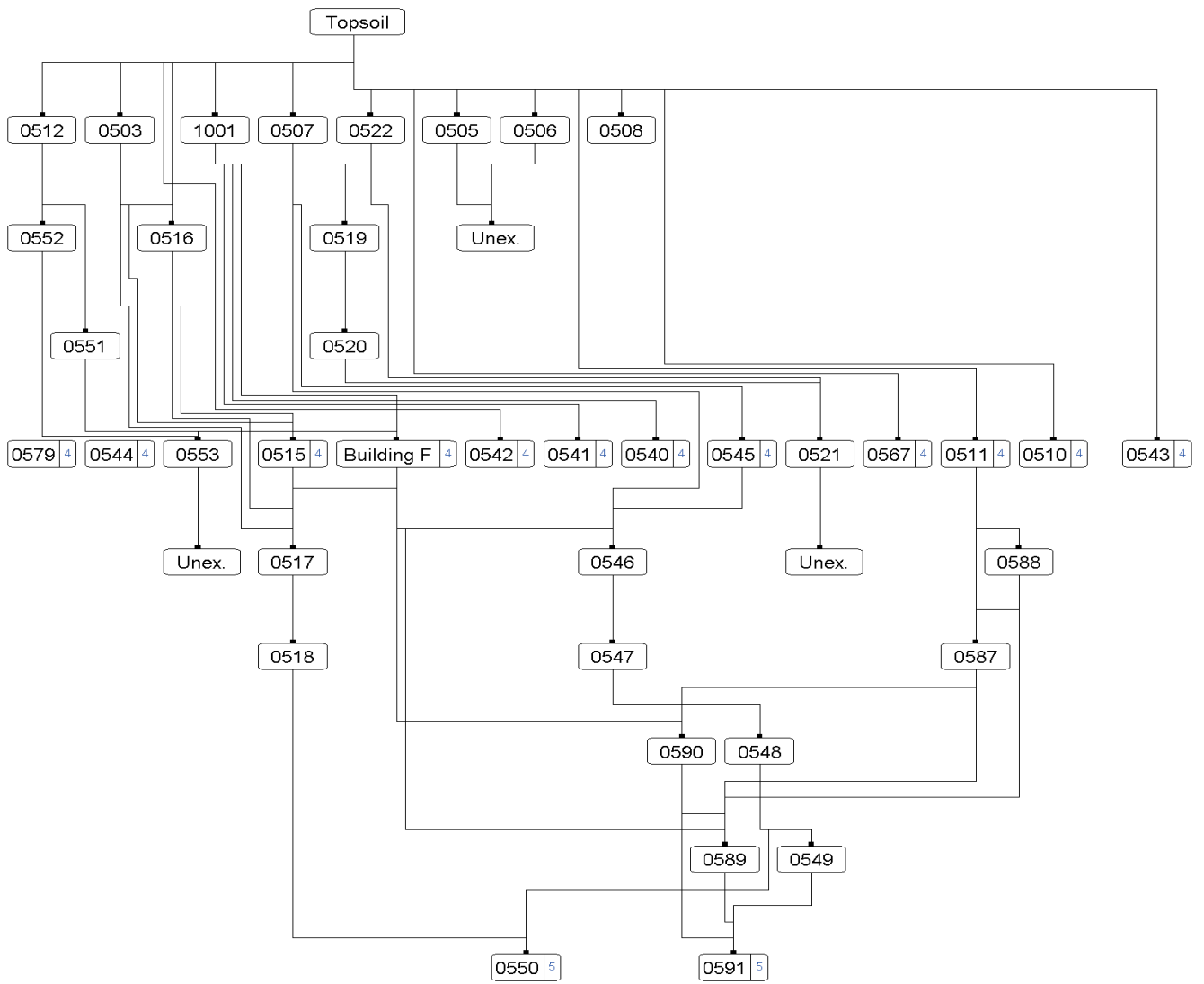
Plate XII: Area II,
Operation 99/2, L1203,
west section, No. 1

Plate XII

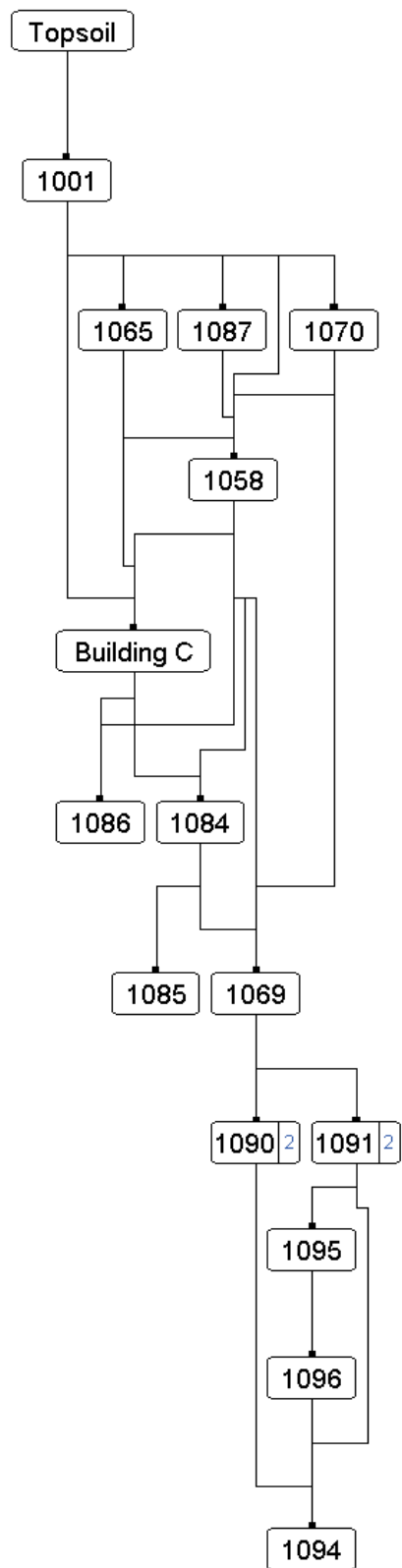


Plate XIII

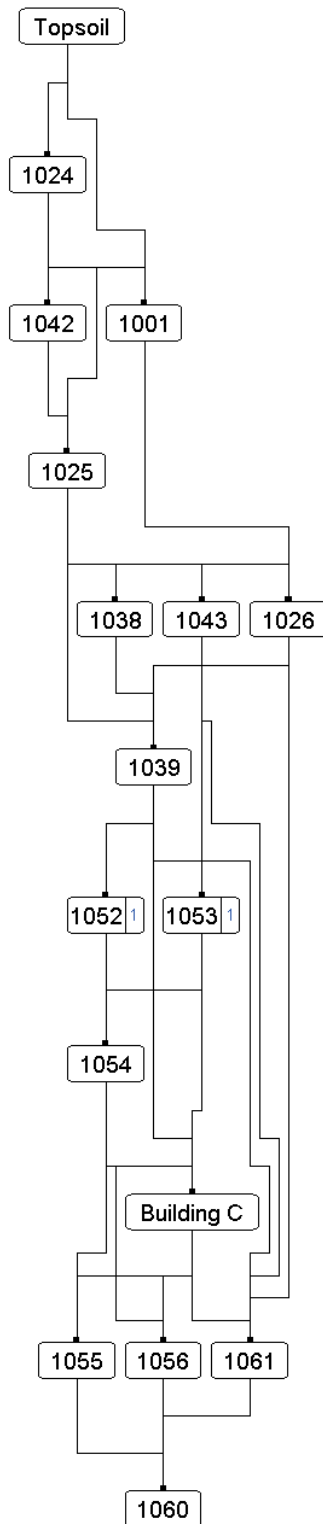
Graphic VII: Area VI



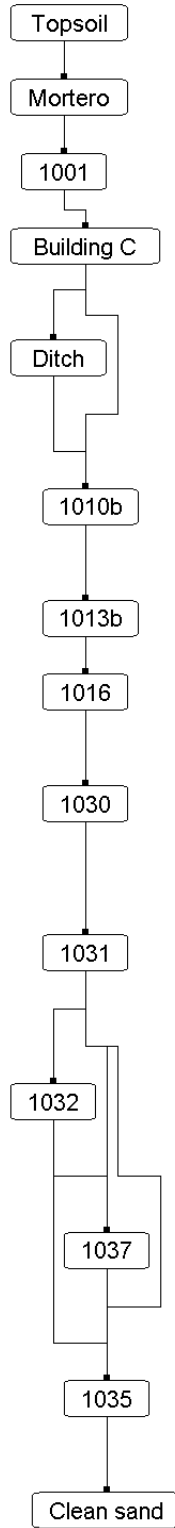
Graphic VI: Area II, west section, Operation 36 and 41



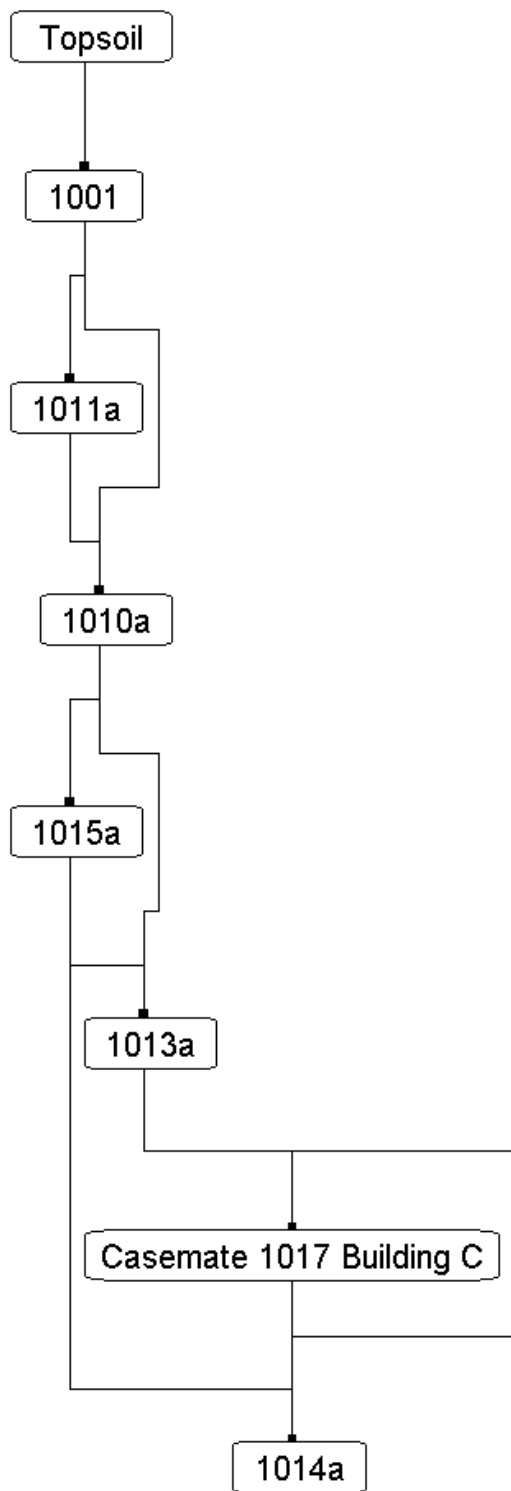
Graphic V: Area II, west section, Operation 32, 33, 34 and 35



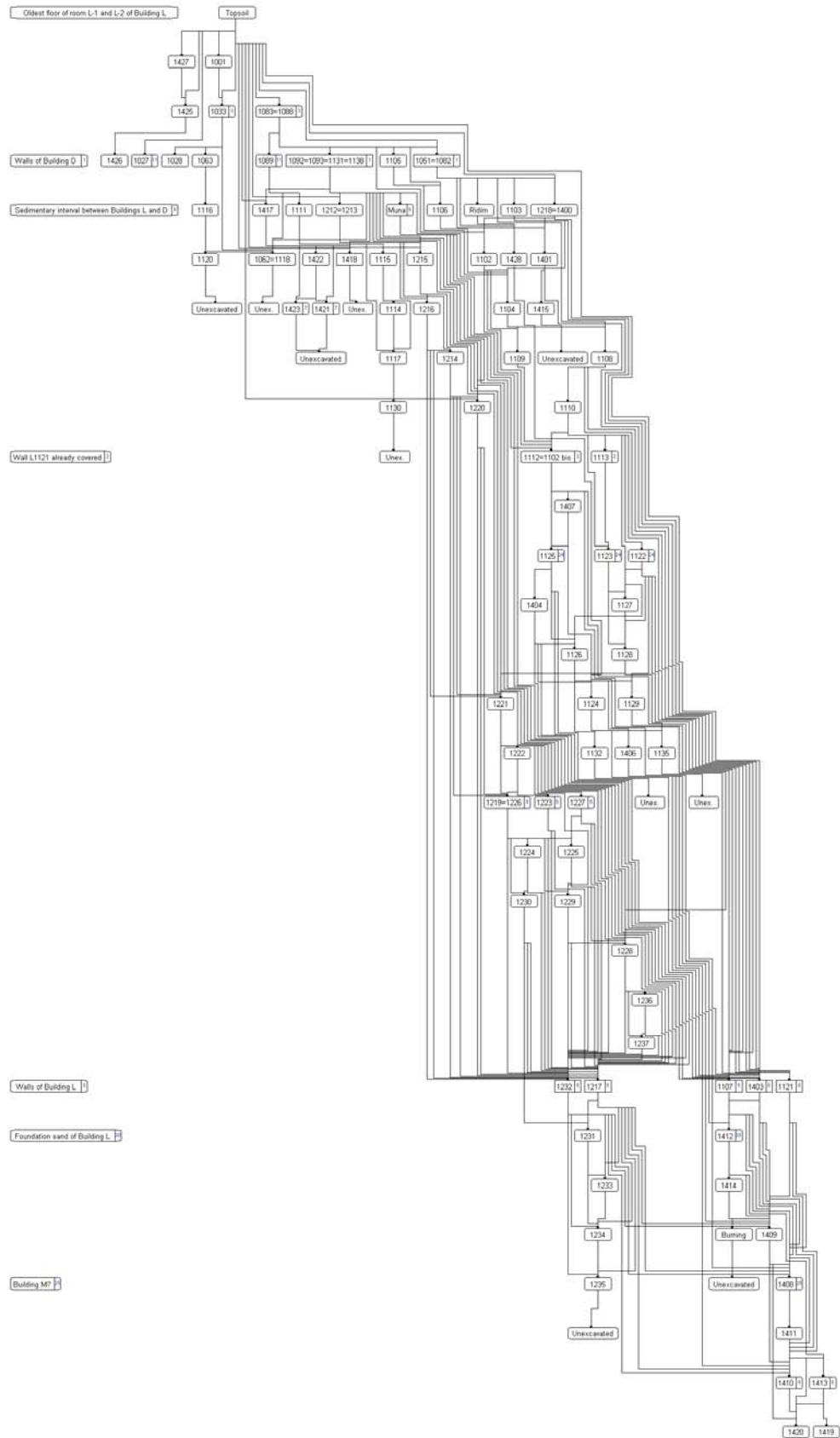
Graphic IV: Area II, west section, Operation 26



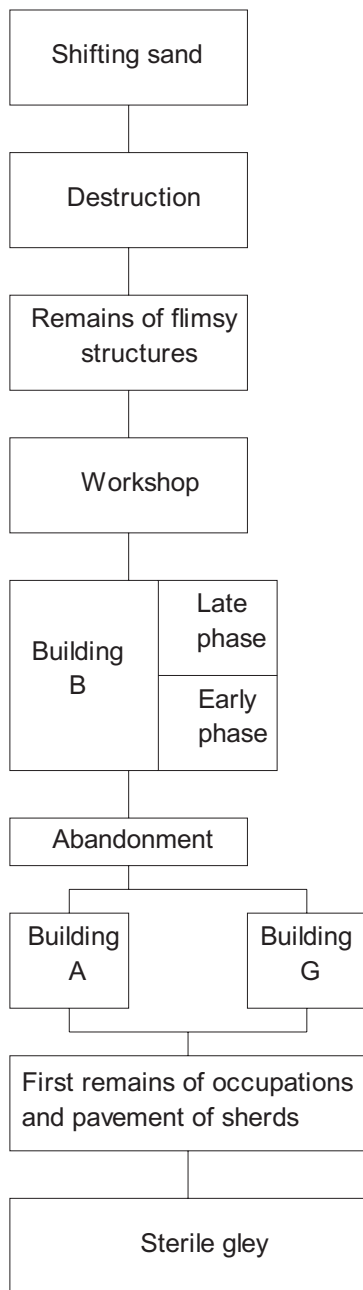
Graphic III: Area II, west section, Operation 25

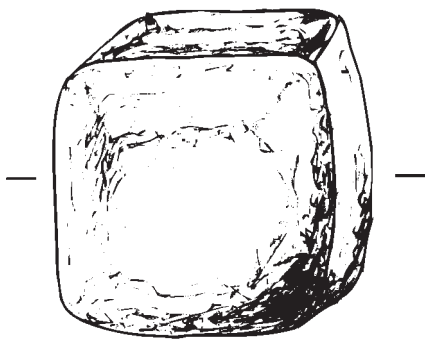


Graphic II: Area II, east section

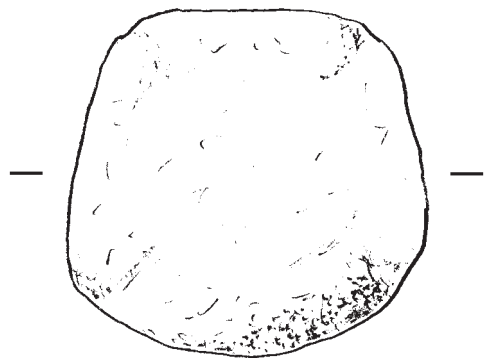
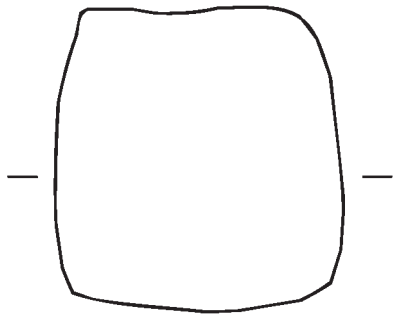


Graphic I: Area I (sketch)

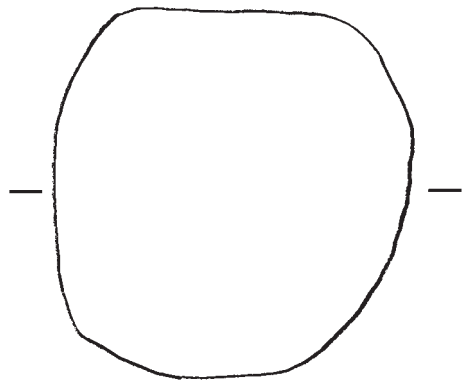




No. 22 F0938A

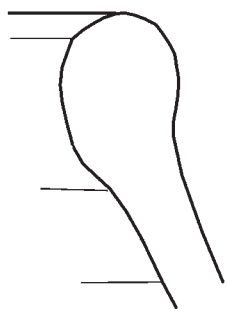


No. 23 F942A

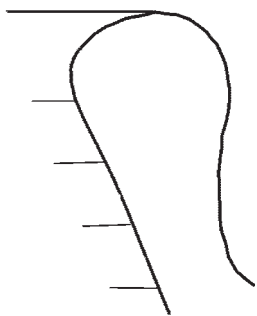


0 1cm

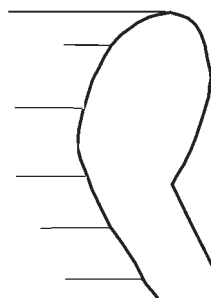
AREA I, L0371



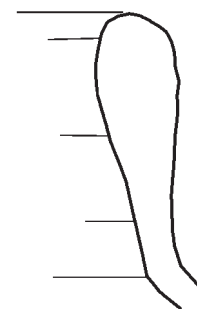
No. 10 C-0628 [006]



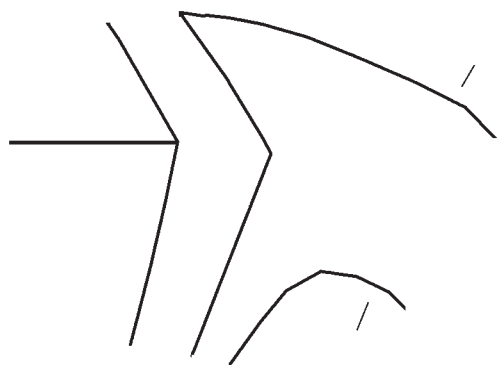
No. 11 C-0628 [008]



No. 12 C-0628 [009]



No. 16 C-0628 [003]



No. 17 C-0628 [012]



No. 20 F0851A



No. 21 F0853A

0 1cm

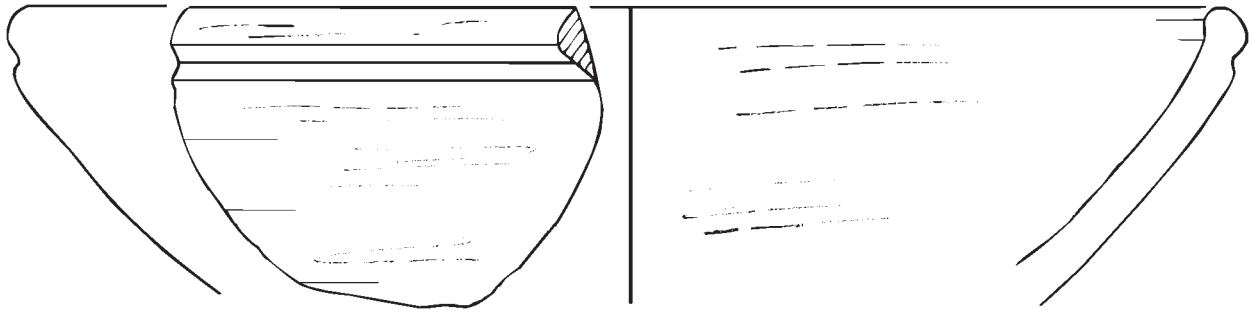
AREA I, L0371

Fig. 1:2



No.19 F0622

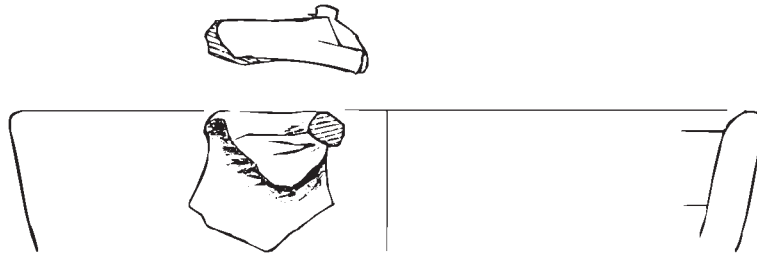
AREA I, L0371



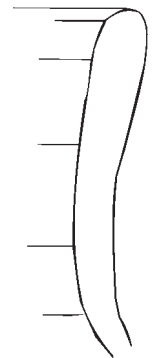
No. 1 P1211A



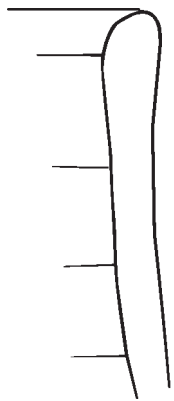
No. 2 C-0628 [010]



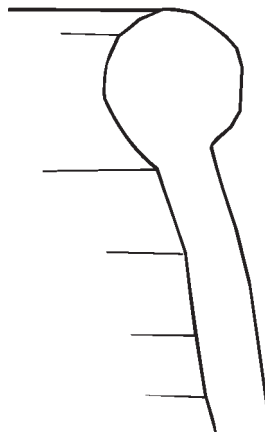
No. 3 P1209A



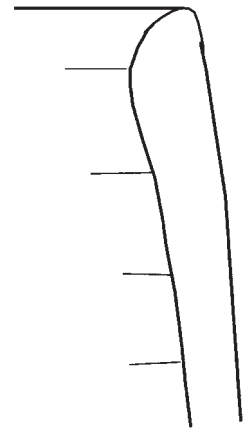
No. 5 C-0628 [001]



No. 6 C-0628 [002]



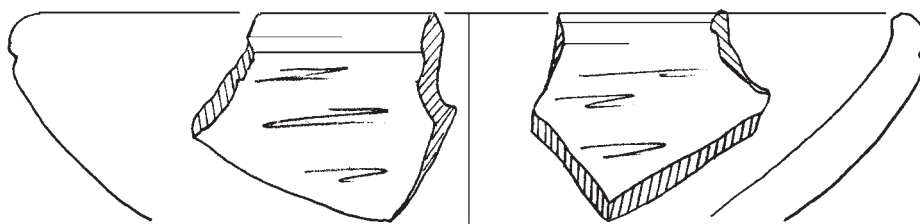
No. 8 C-0628 [004]



No. 9 C-0628 [005]

0 1cm

Fig. 1:1



No. 1 P1109A



No. 2 C-0427 [037]



No. 3 C-0427 [080]



No. 4 C-0644 [013]



No. 5 C-0060 [003]



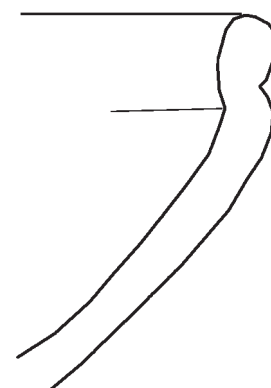
No. 6 C-0059 [010]



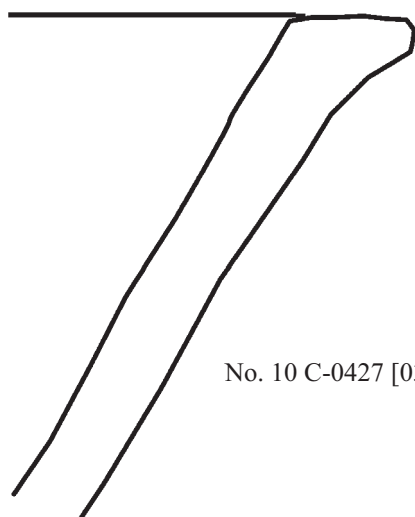
No. 7 C-0644 [021]



No. 8 C-0644 [014]



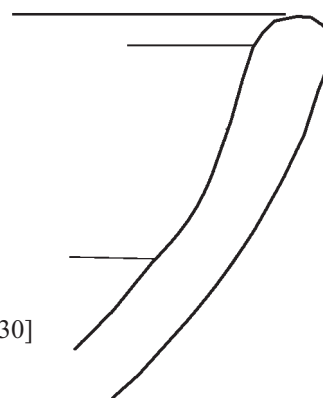
No. 9 C-0427 [044]



No. 10 C-0427 [031]



No. 11 C-0427 [032]



No. 12 C-0427 [030]



AREA I, L0040 = L0043 = L0044

Fig. 3:1

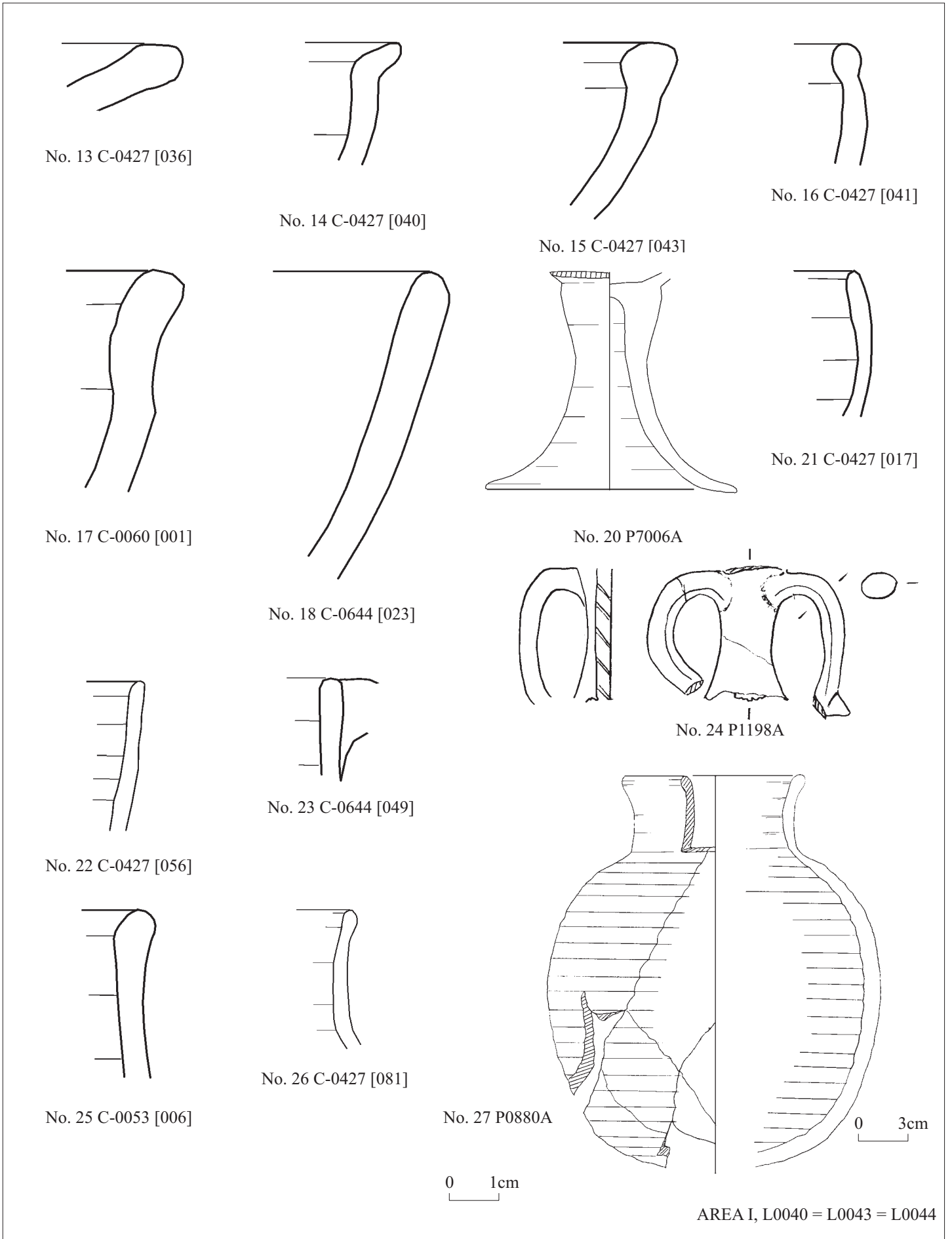
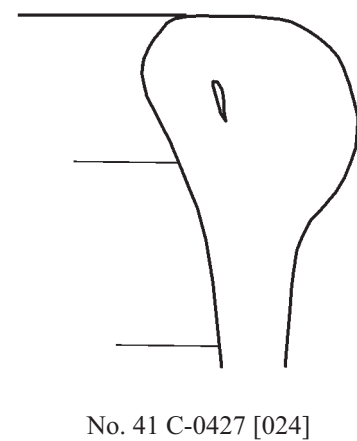
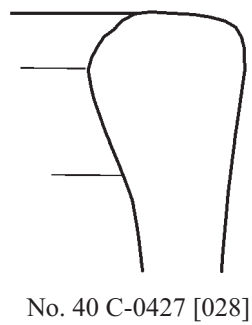
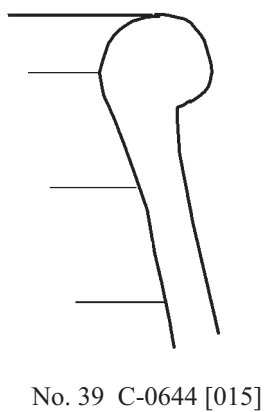
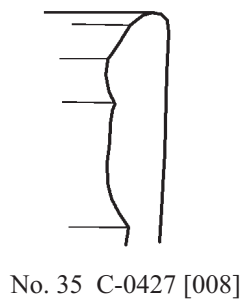
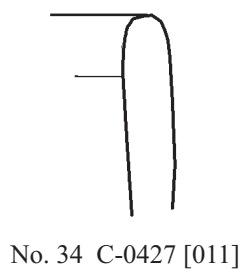
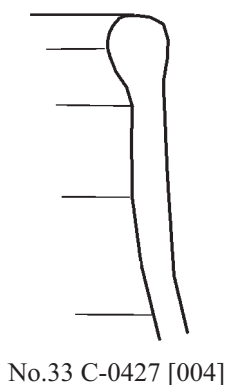
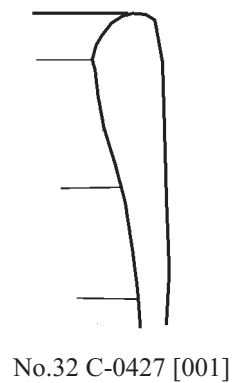
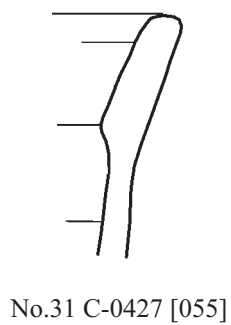
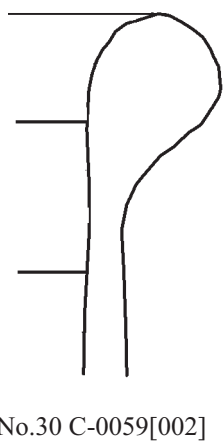
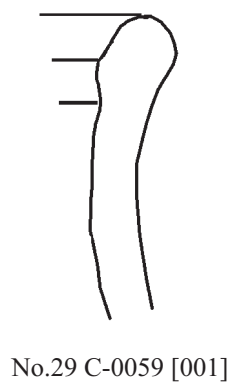
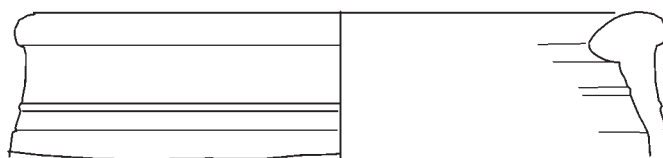


Fig. 3:2



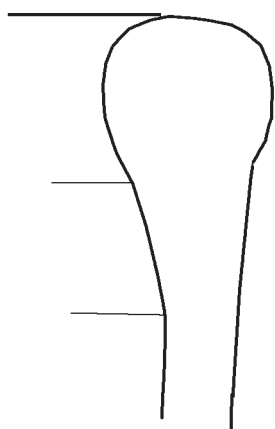
0 1cm



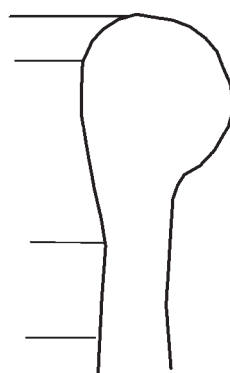
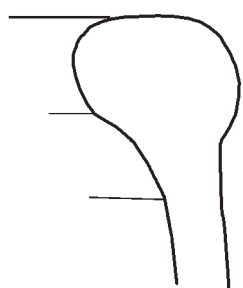
0 3cm

AREA I, L0040 = L0043 = L0044

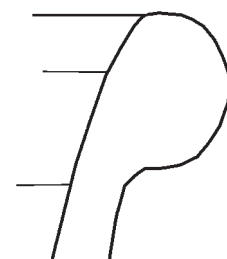
Fig. 3:3



No. 44 C-0427 [027]

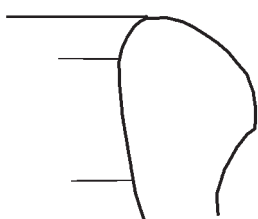


No. 45 C-0427 [021]

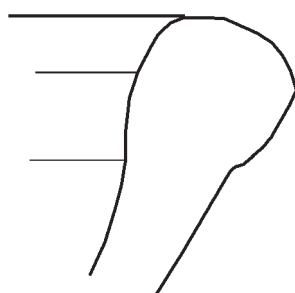


No. 46 C-0427 [026]

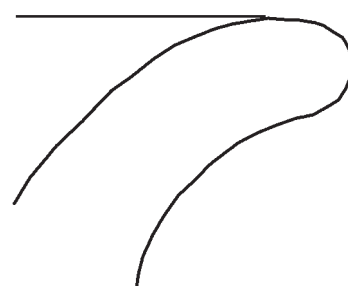
No. 43 C-0427 [022]



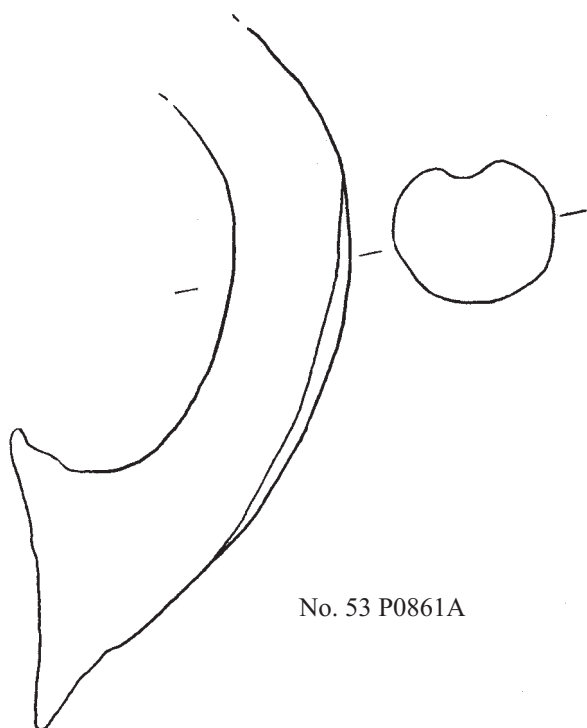
No. 47 C-0427 [025]



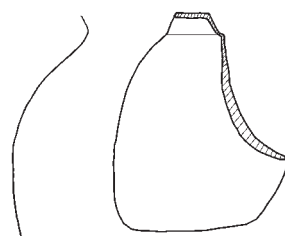
No. 48 C-0427 [020]



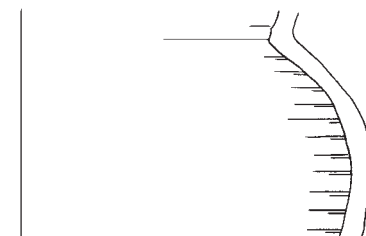
No. 51 C-0054 [003]



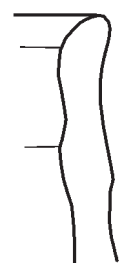
No. 53 P0861A



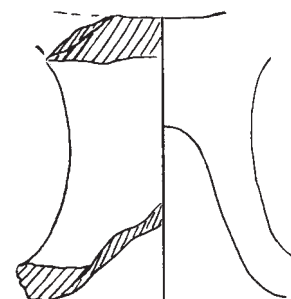
No. 54 P0131A



0 2cm



No. 55 C-0053 [003]

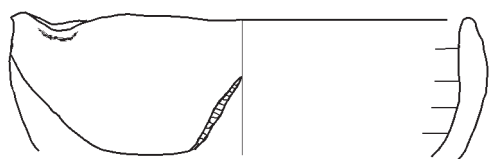


No. 59 P1230A

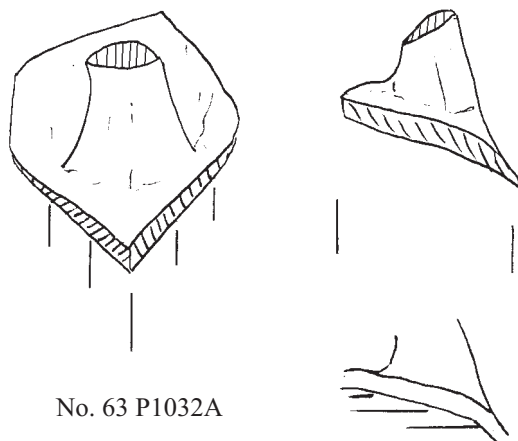
0 1cm

AREA I, L0040 = L0043 = L0044

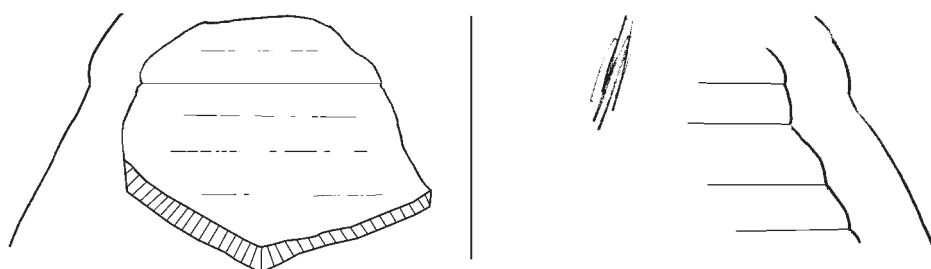
Fig. 3:4



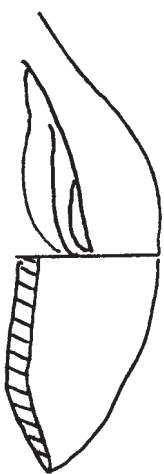
No. 62 P1270A



No. 63 P1032A



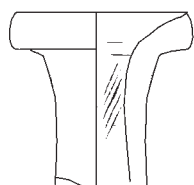
No. 64 P1232A



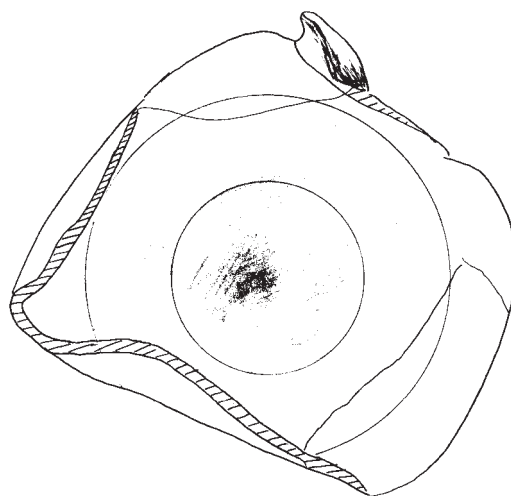
No. 65 P1274A



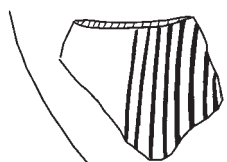
No. 79 P1231A



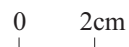
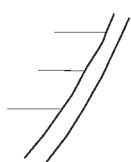
No. 87 P0084A



No. 86 P0761A

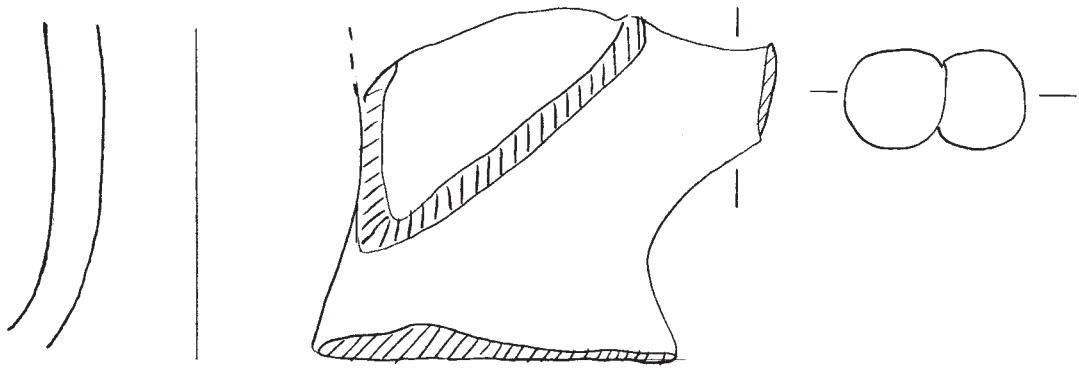


No. 90 P0054A

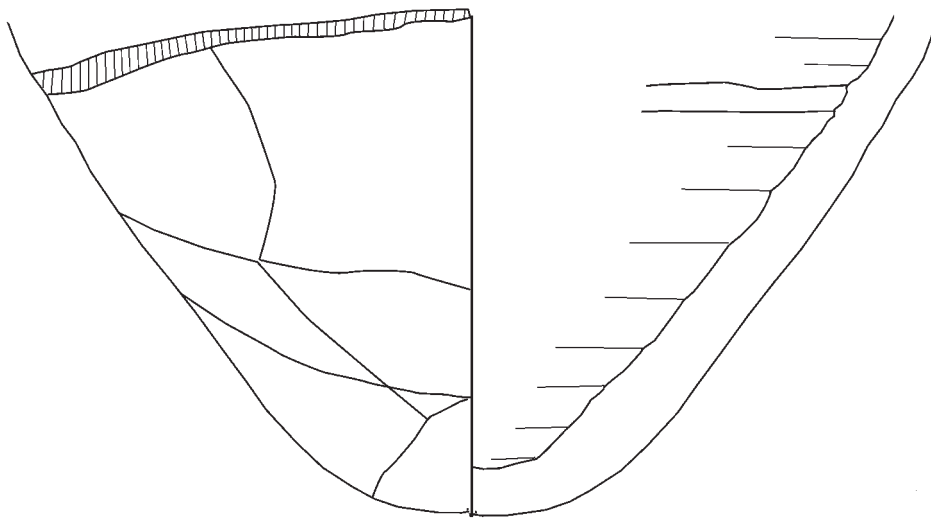


AREA I, L0040 = L0043 = L0044

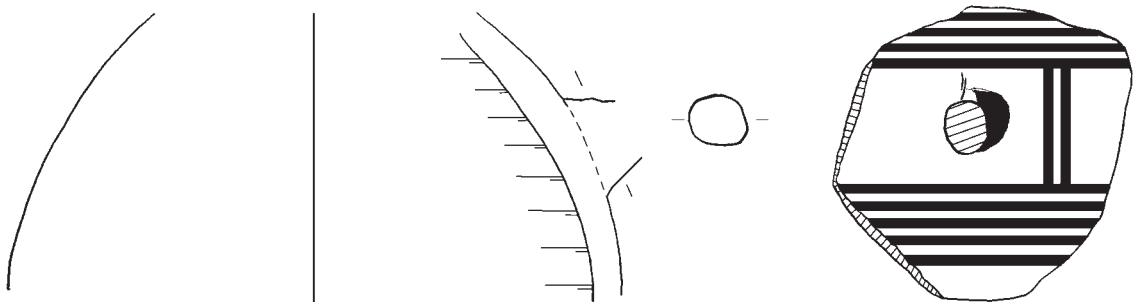
Fig. 3:5



No. 91 P0073A



No. 94 P1272A



No. 98 P0057A



No. 101 F0025A



No. 102 F0438A



No. 108 F0548A

0 1cm

AREA I, L0040 = L0043 = L0044

Fig. 3:6



No. 99 F0500 2

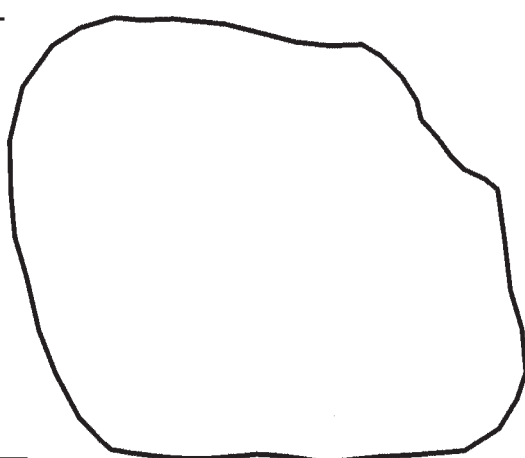
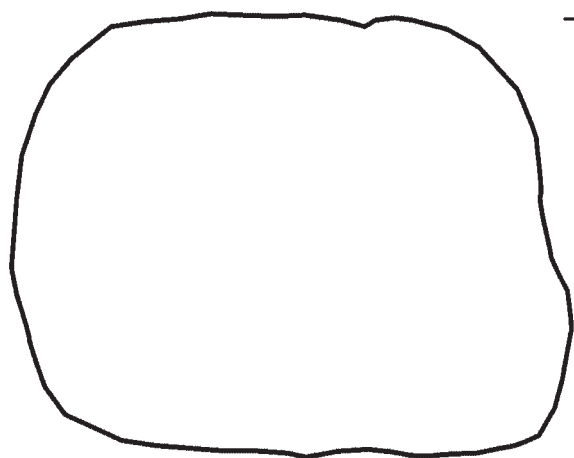


No. 101 F0025A

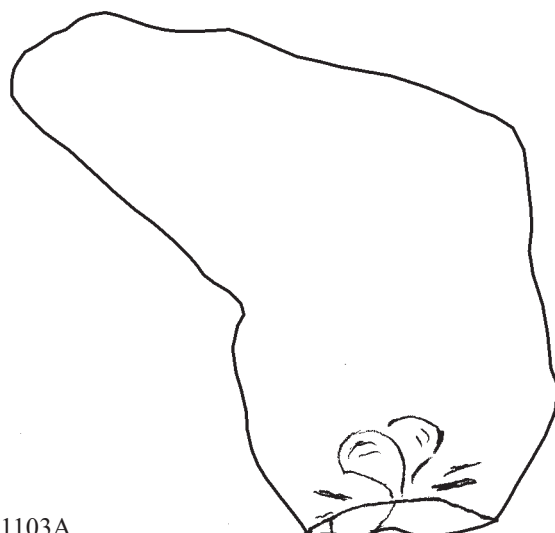
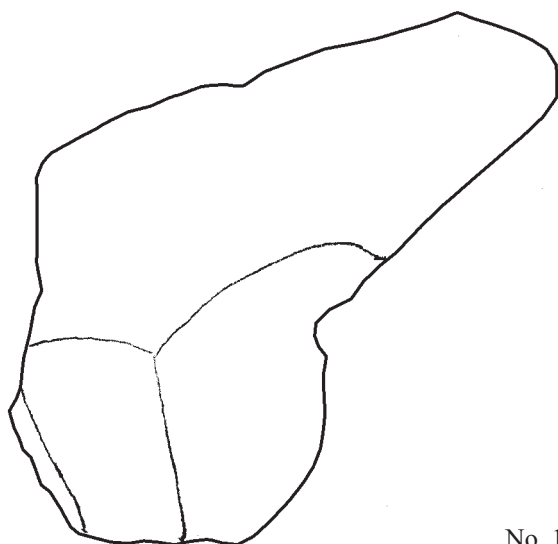
2 bis

AREA I, L0040 = L0043 = L0044

Plate 2



No. 112 F0987A

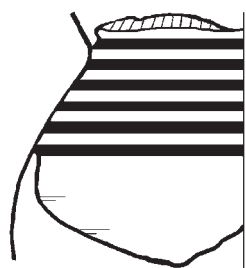


No. 124 F1103A

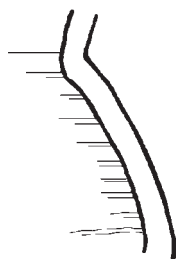
0 1cm

AREA I, L0040 = L0043 = L0044

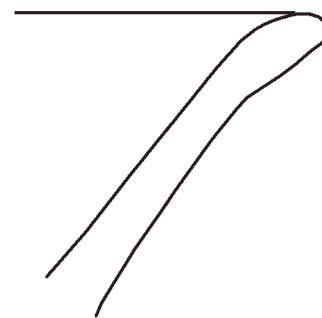
Fig. 3:7



No. 1 P0083A



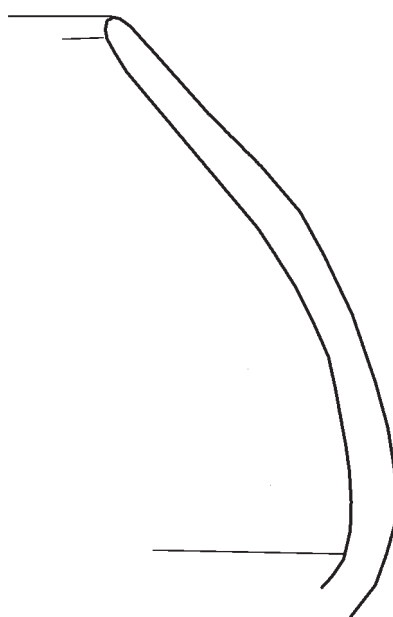
No. 2 C-0244 [002]



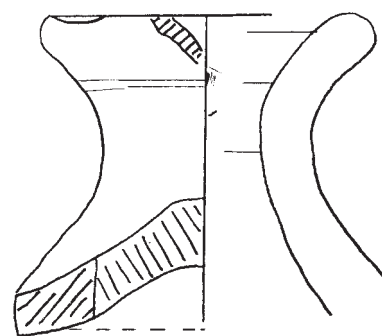
No. 3 C-0244 [001]



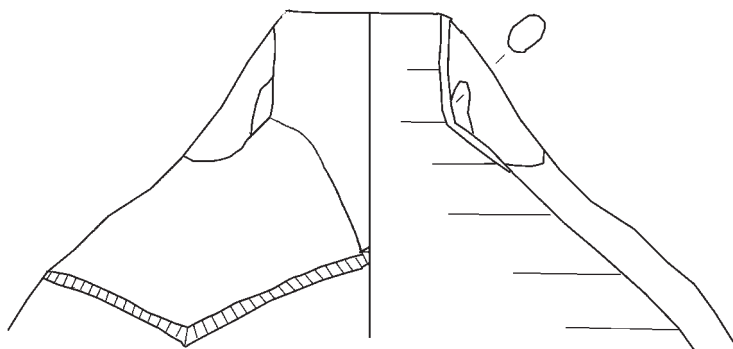
No. 4 C-0244 [003]



No. 5 C-0244 [004]



No. 6 P0616A



No. 8 P0611A

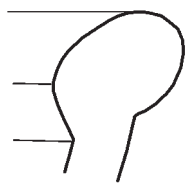


No. 9 C-0235 [001]

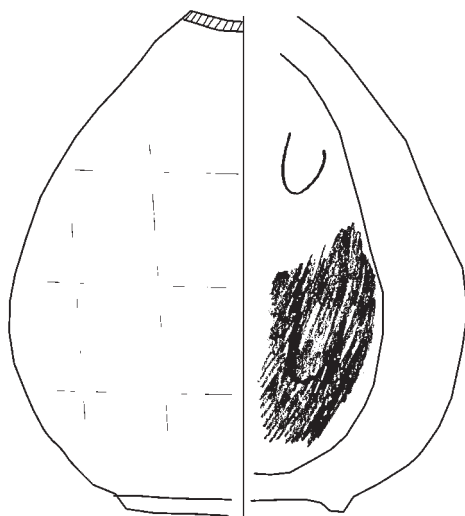
0 1cm

AREA I, L0050 = L0052

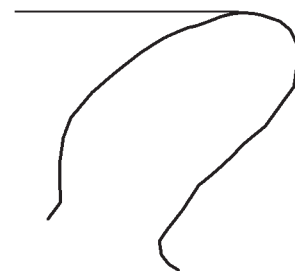
Fig. 4:1



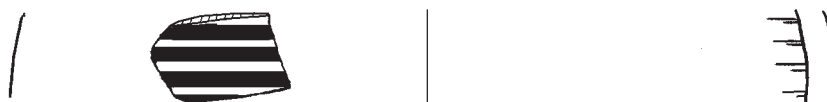
No. 11 C-0244 (2) [001]



No. 12 P0609A

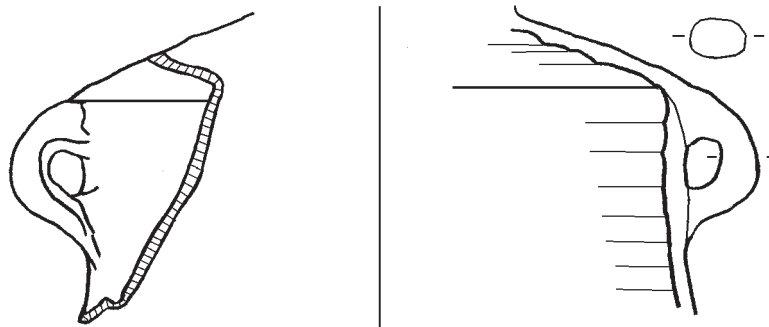


No. 13 C-0244 [007]

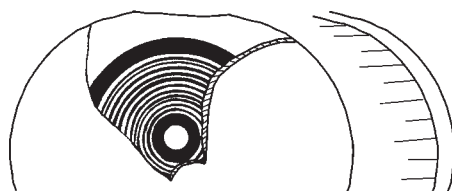


No. 16 P0800A

0 1cm



No. 19 P0511A

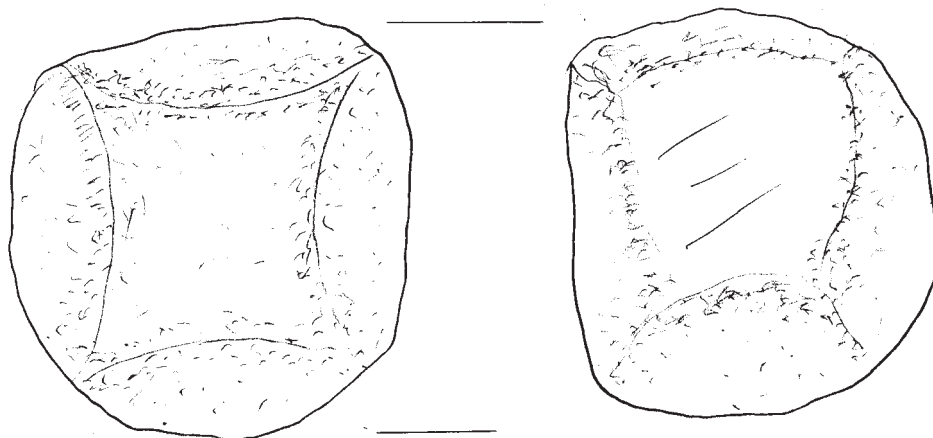


No. 21 P0730A

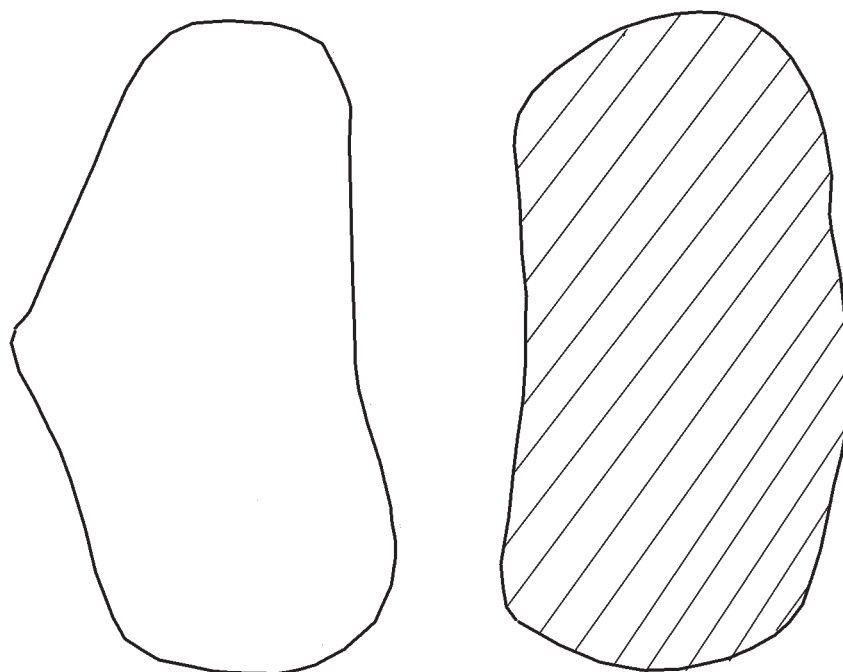
0 2cm

AREA I, L0050 = L0052

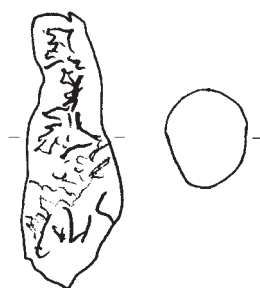
Fig. 4:3



No. 23 F0082B



No. 24 F0983A

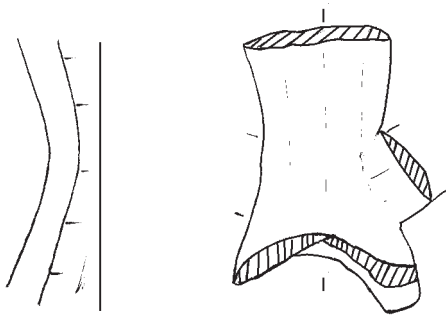


No. 25 F0107A

0 1cm

AREA I, L0050 = L0052

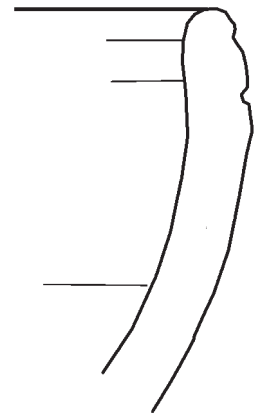
Fig. 4:4



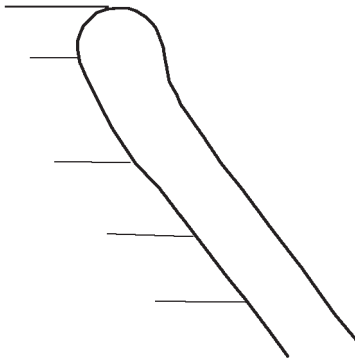
No. 1 P1202A



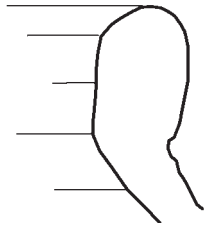
No. 2 C-0627 (2) [003]



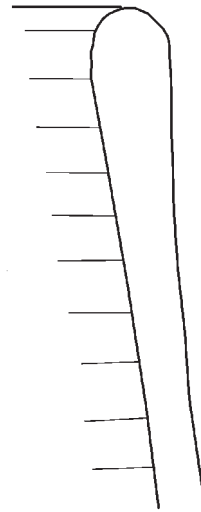
No. 3 C-0627 (2) [001]



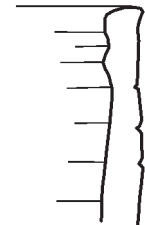
No. 4 C-0627 (2) [014]



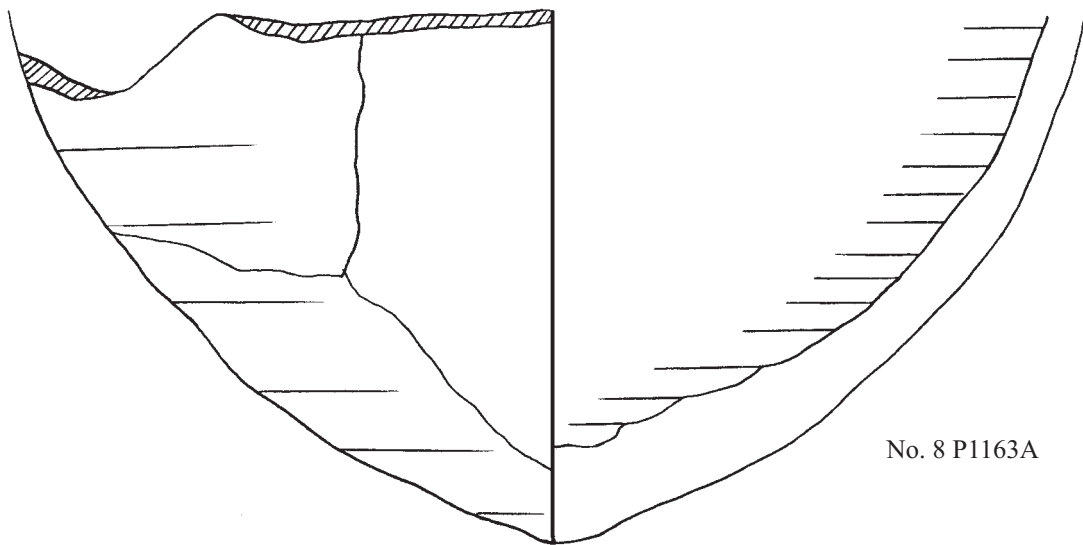
No. 5 C-0627 (2) [018]



No. 6 C-0627 (2) [005]



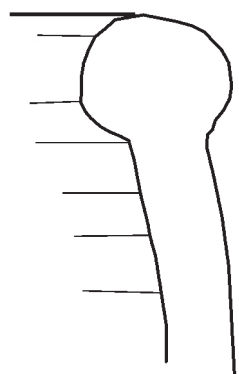
No. 7 C-0627 (2) [025]



No. 8 P1163A

0 1cm

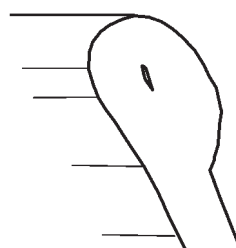
Fig. 5:1



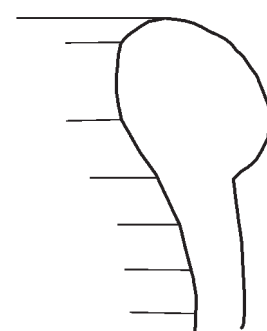
No. 10 C-0627 (2) [013]



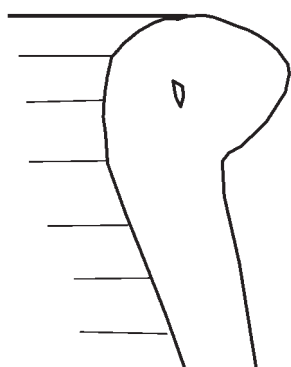
No. 11 C-0627 (2) [017]



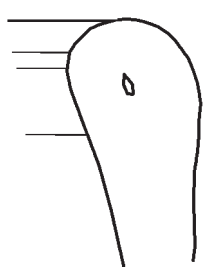
No. 12 C-0627 (2) [031]



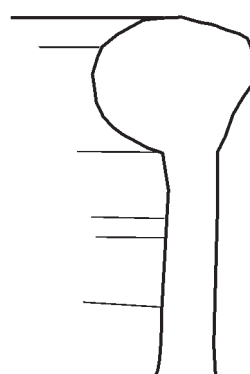
No. 13 C-0627 (2) [012]



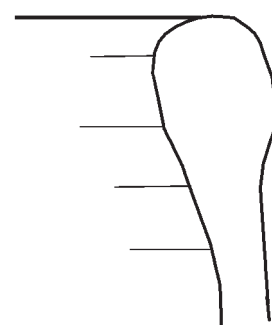
No. 14 C-0627 (2) [029]



No. 15 C-0627 (2) [030]

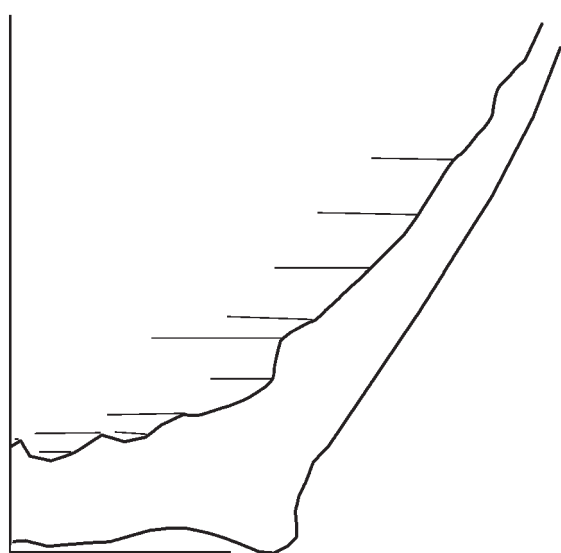


No. 16 C-0627 (2) [019]



No. 17 C-0627 (2) [010]

0 1cm



No. 18 C-0627 (2) [026]

0 1cm

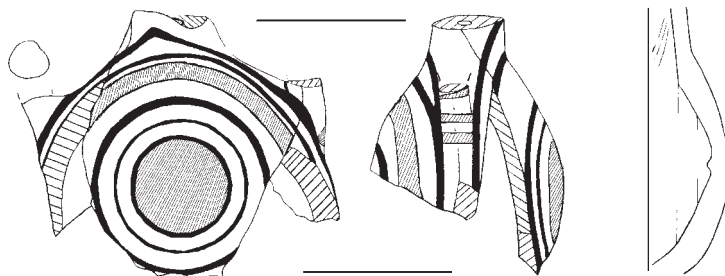


No. 19 C-0627 (2) [004]



No. 20 C-0627 (2) [023]

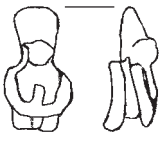
0 1cm



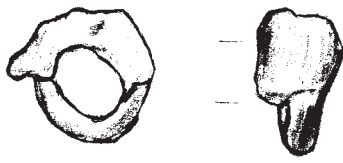
No. 22 P2023A

0 2cm

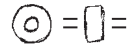
Fig. 5:2



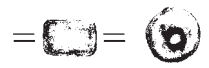
No. 25 F0688A



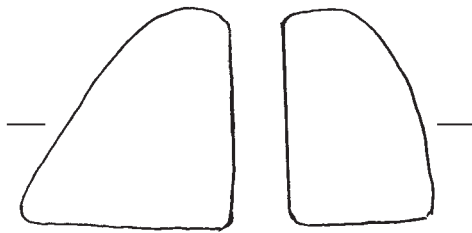
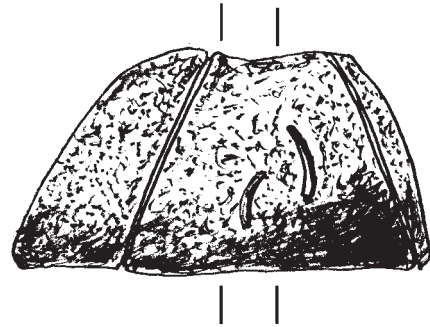
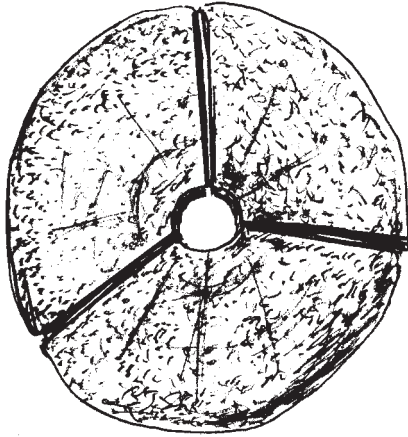
No. 28 F0694A



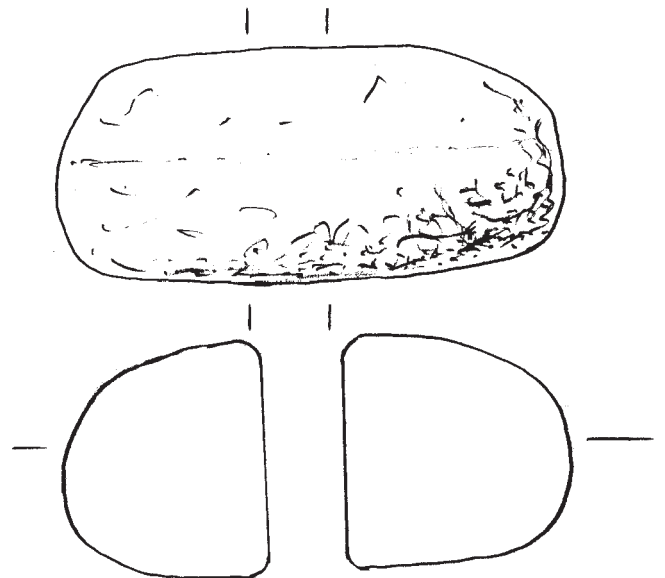
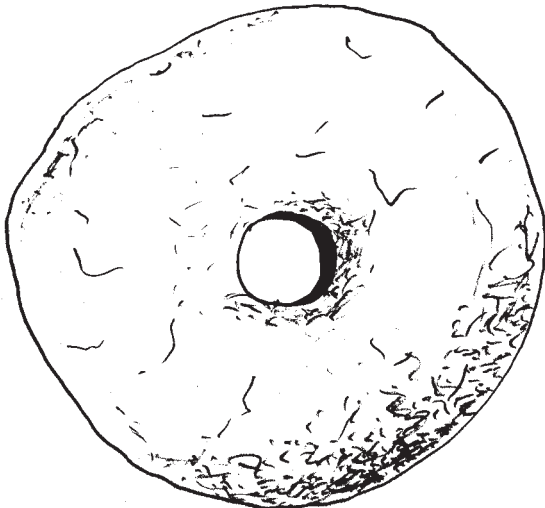
No. 30 F0660A



No. 31 F0706A



No. 32 F0936A



No. 33 F0948A

0 1cm

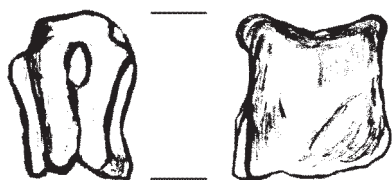
Fig. 5:3



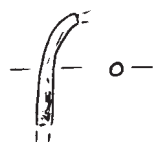
No. 26 F0629A

AREA I, L0266

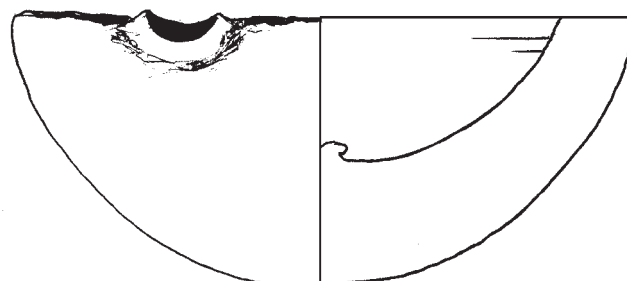
Plate 3



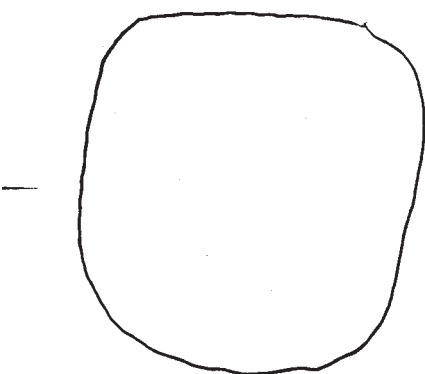
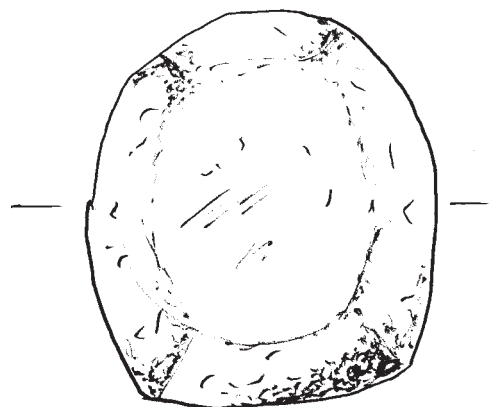
No. 34 F0698A



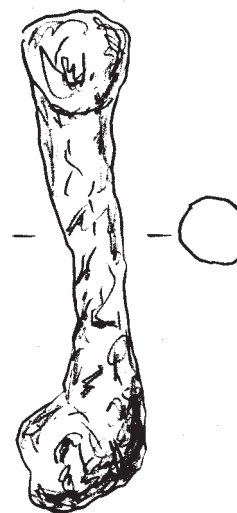
No. 37 F0873A



No. 39 F1121A



No. 40 F0943A



No. 46 F0866A



AREA I, L0266

Fig. 5:4

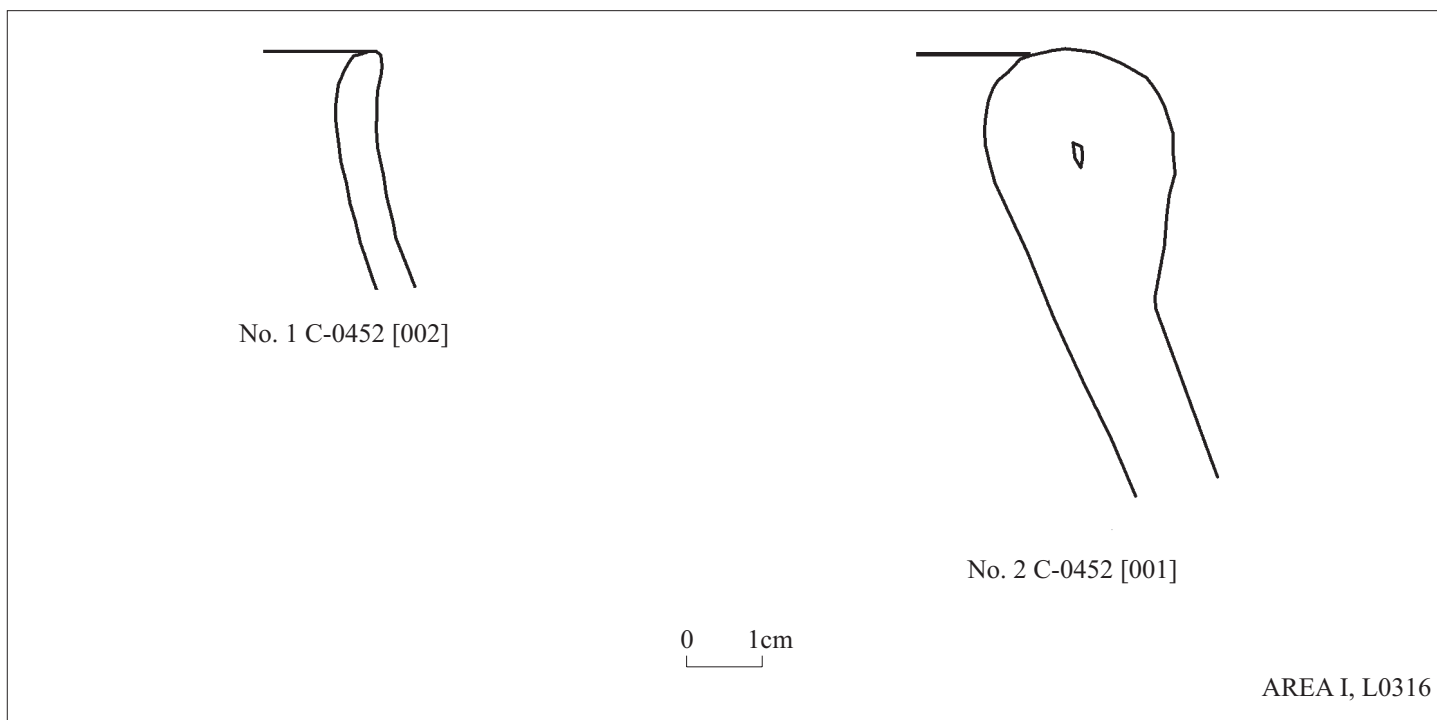


Fig. 6

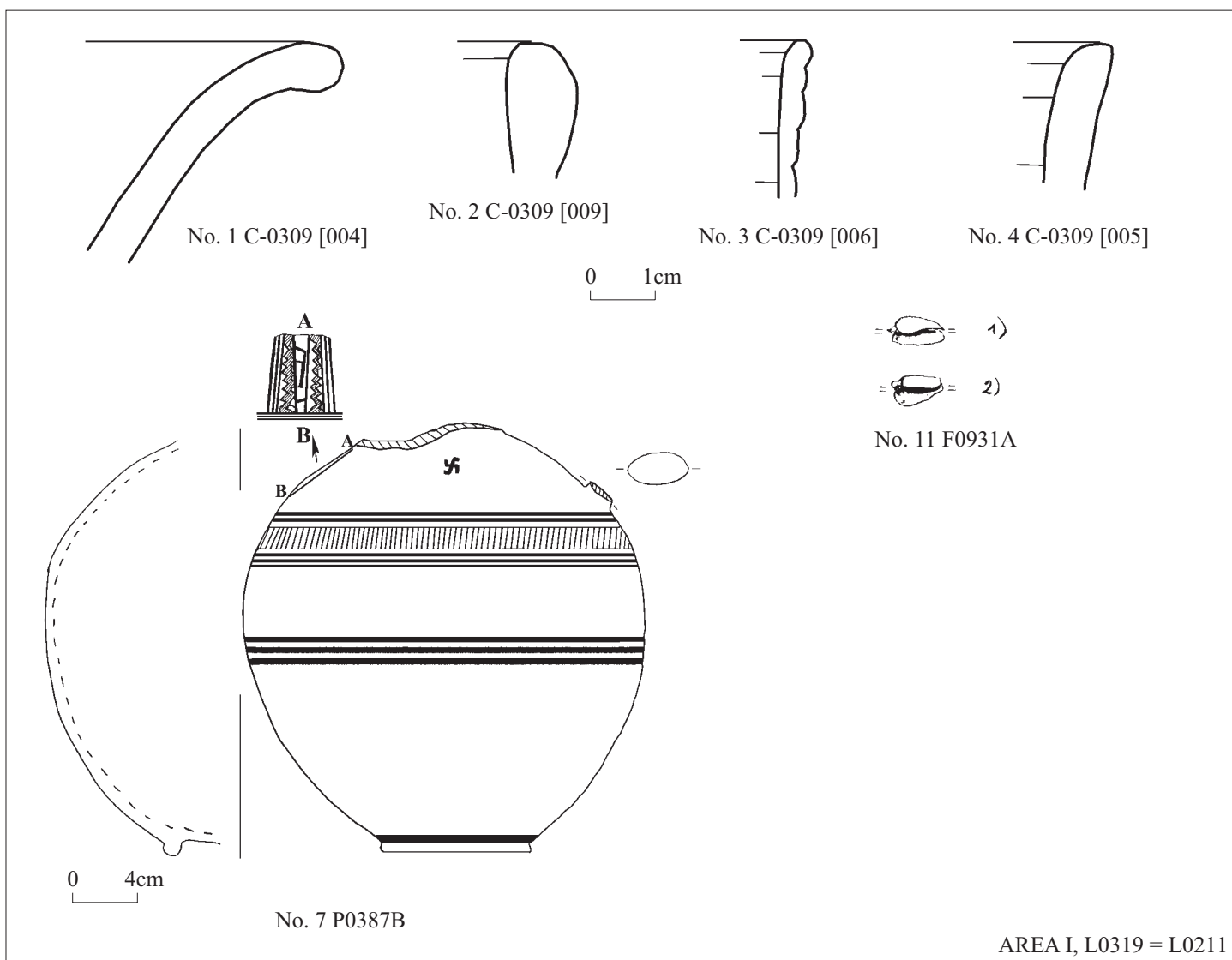


Fig. 7



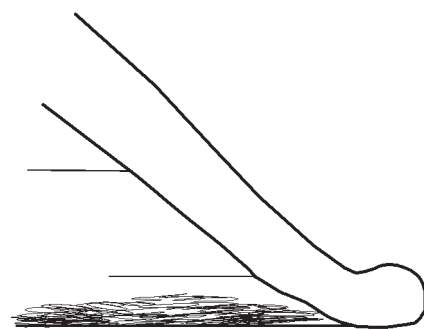
No. 10 F0235

AREA I, L0319 = L0211

Plate 4



No. 1 C-9002 [002]



No. 3 C-9002 [001]

0 1cm

AREA I, L0345

Fig. 8

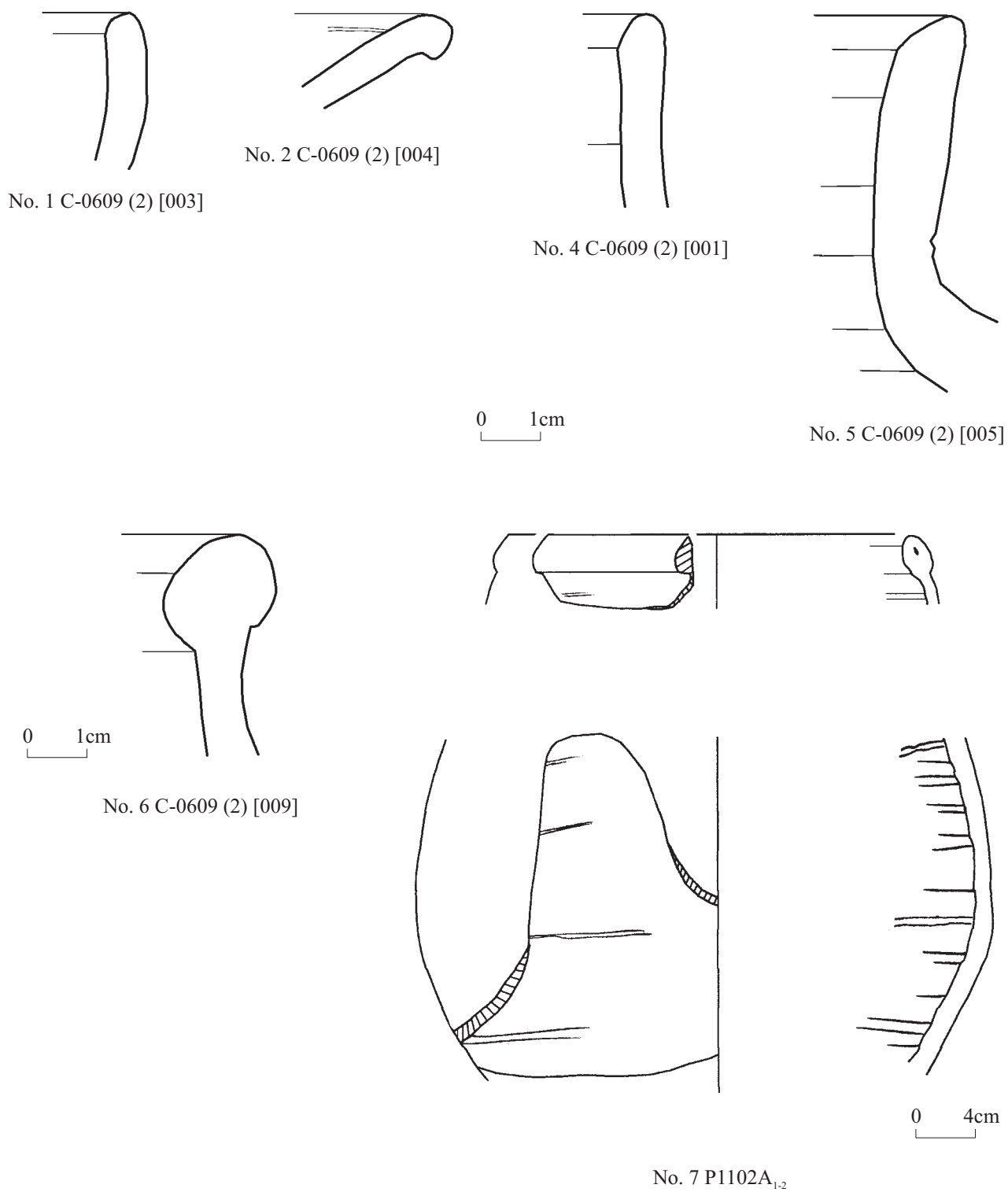
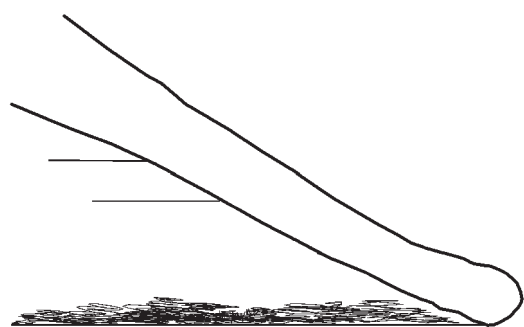
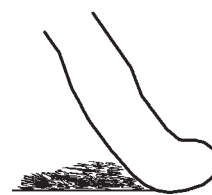


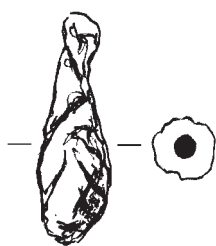
Fig. 9:1



No. 9 C-0609 (2) [008]



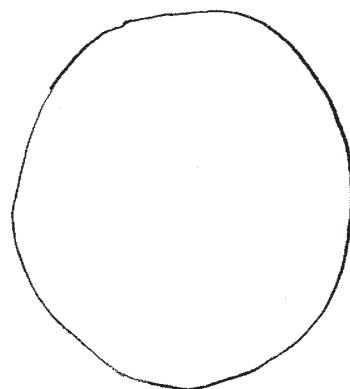
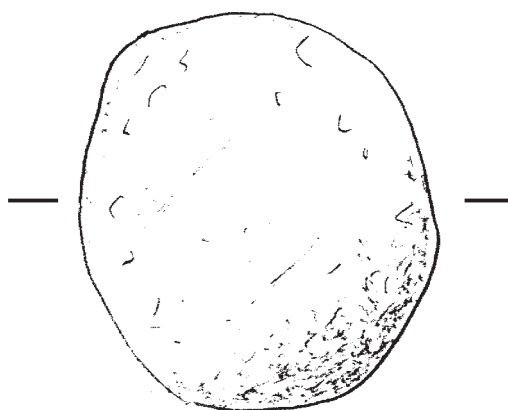
No. 10 C-0609 (2) [006]



No. 16 F0864A



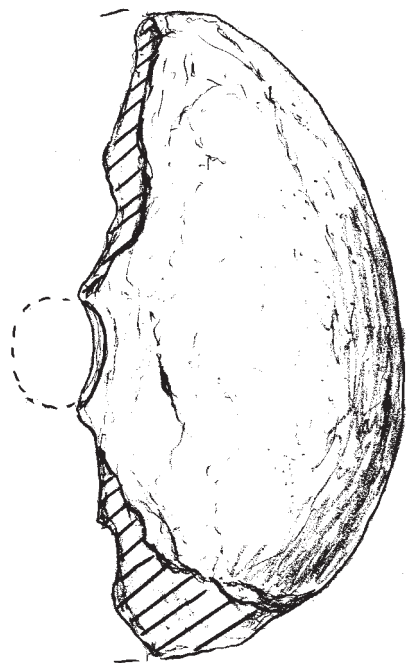
No. 17 F0872A



No. 18 F0945A

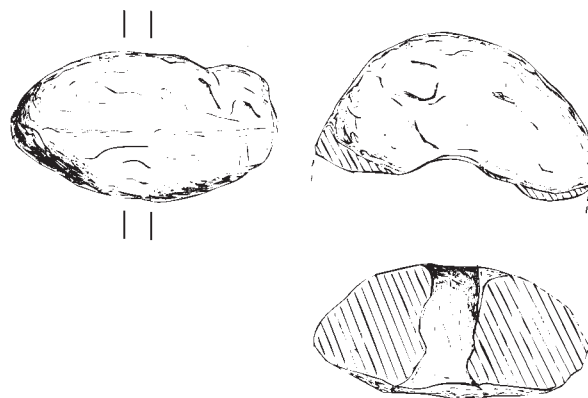
0 1cm

Fig. 9:2



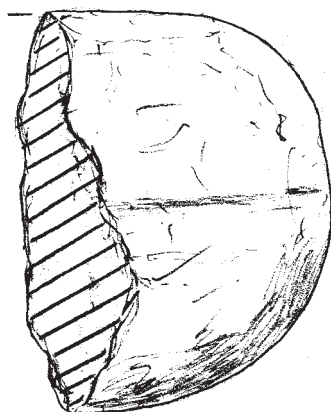
No. 1 F0638A

0 1cm



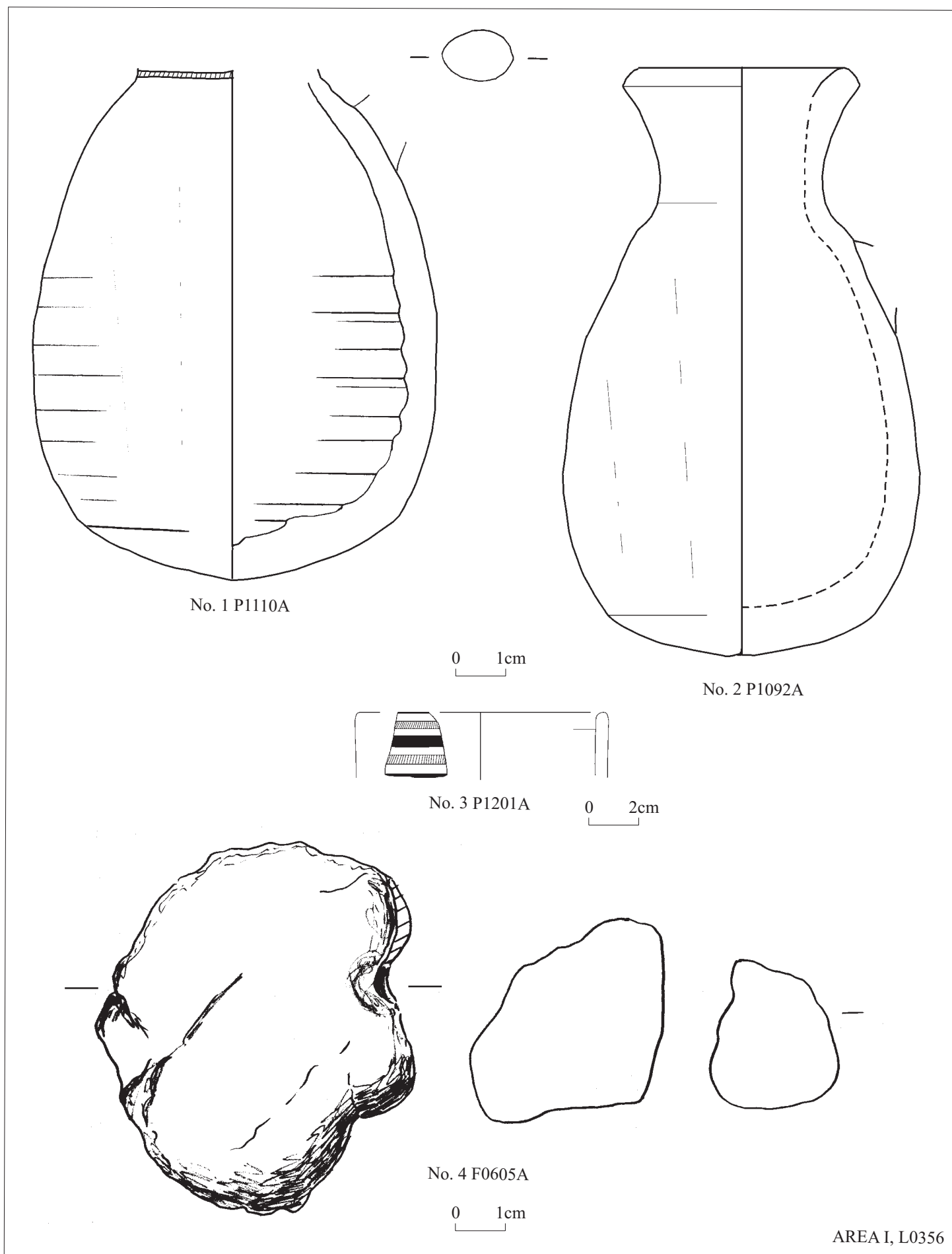
No. 2 F0641A

0 2cm



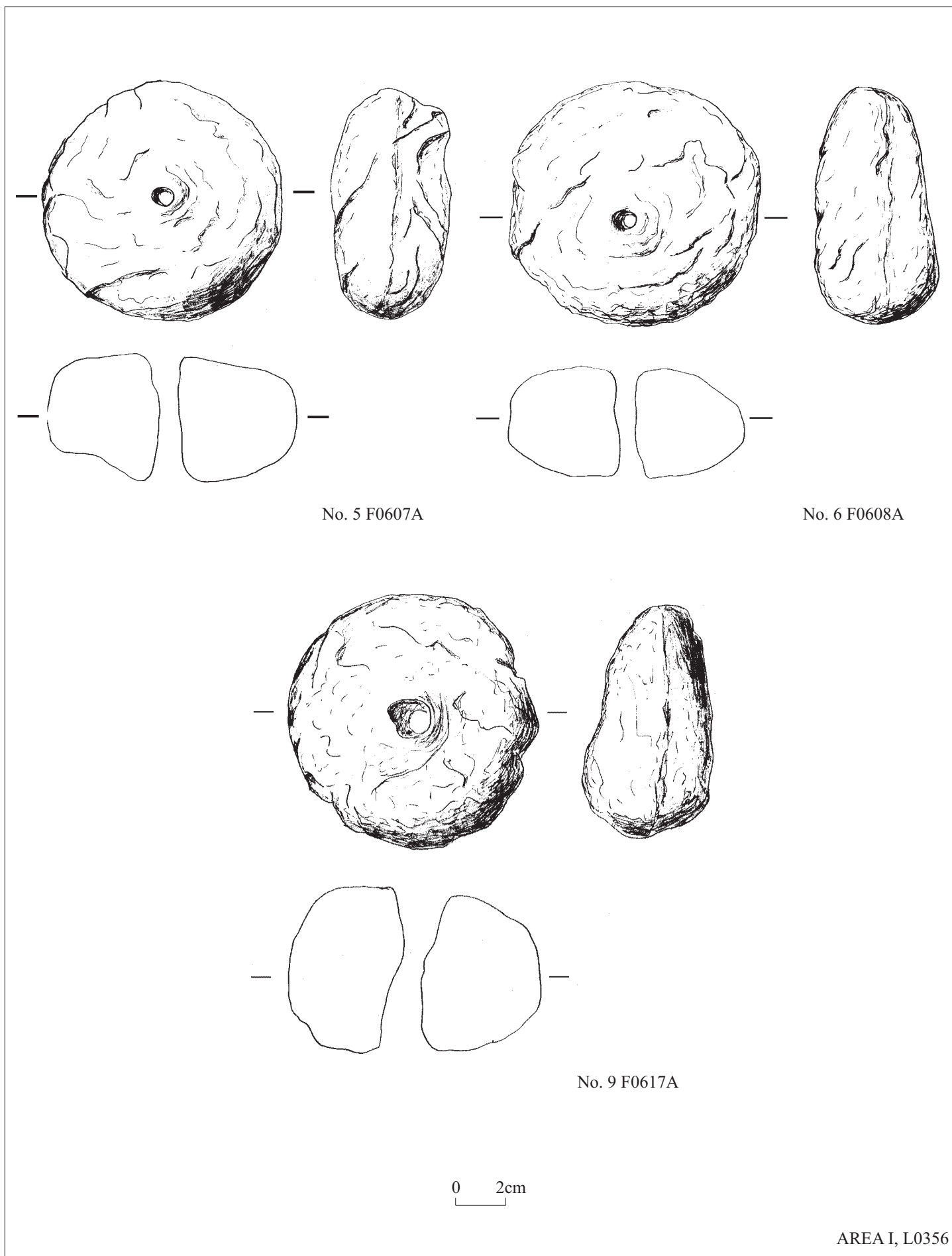
No. 1 F0638A

0 1cm



AREA I, L0356

Fig. 11:1



AREA I, L0356

Fig. 11:2

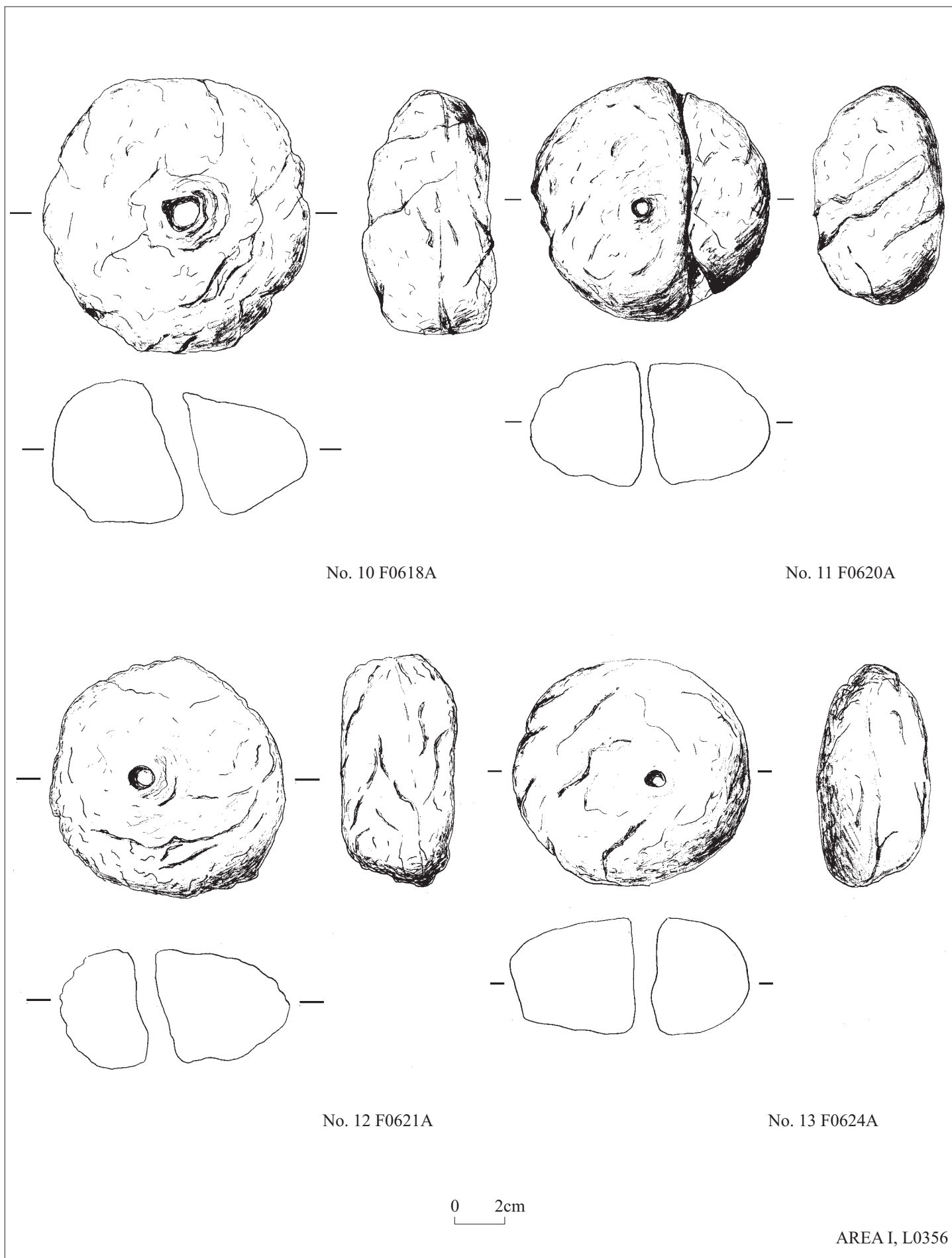


Fig. 11:3

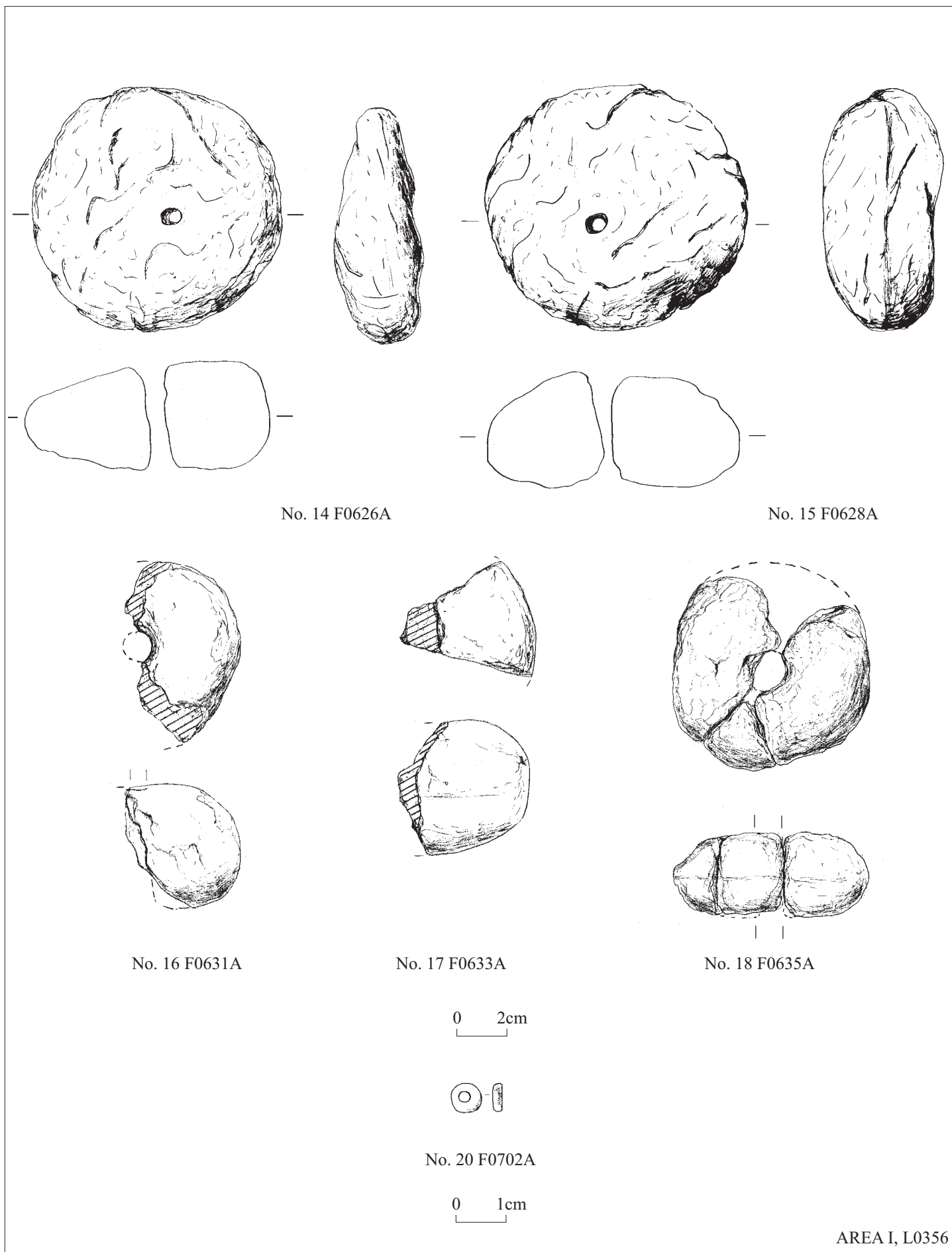


Fig. 11:4

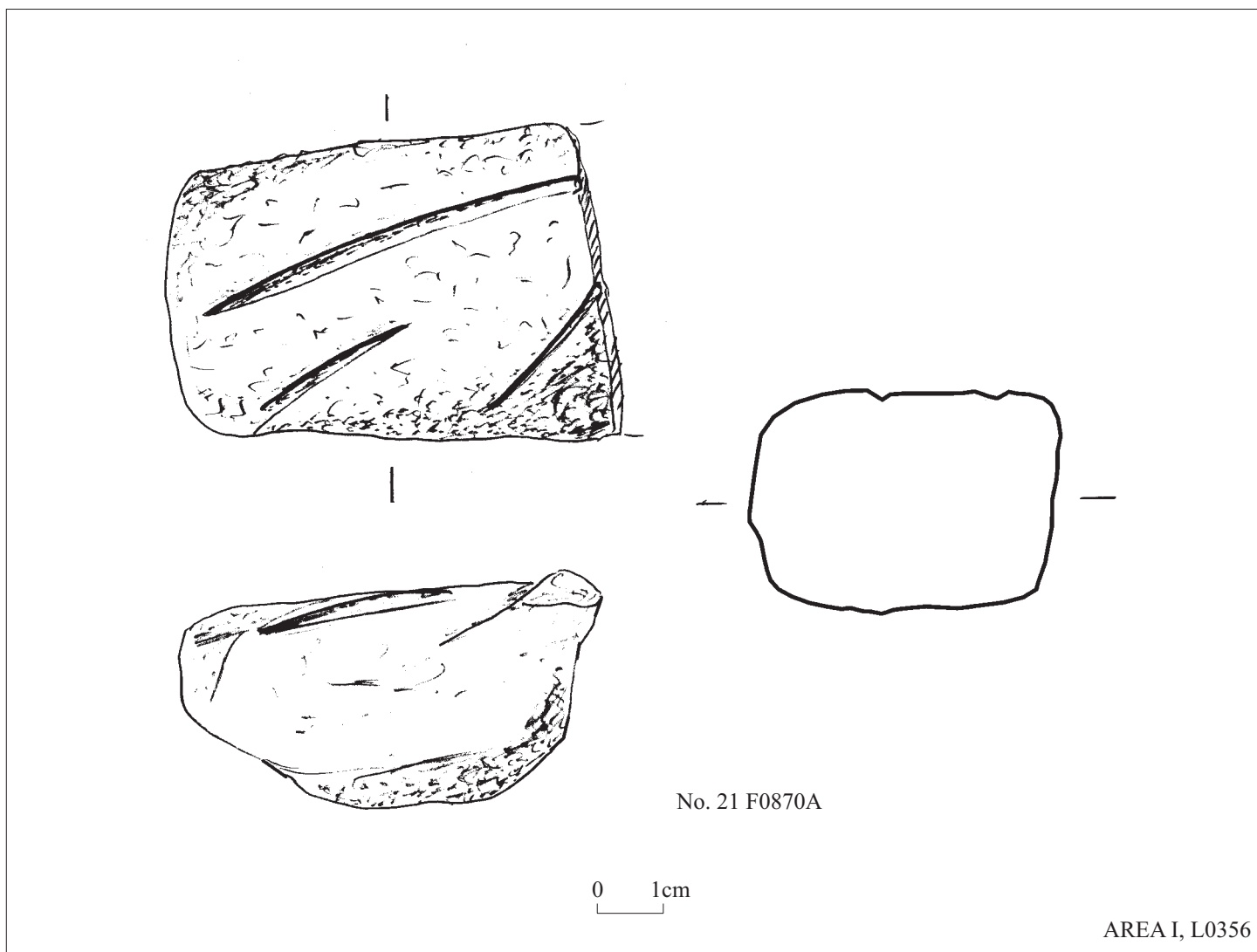


Fig. 11:5

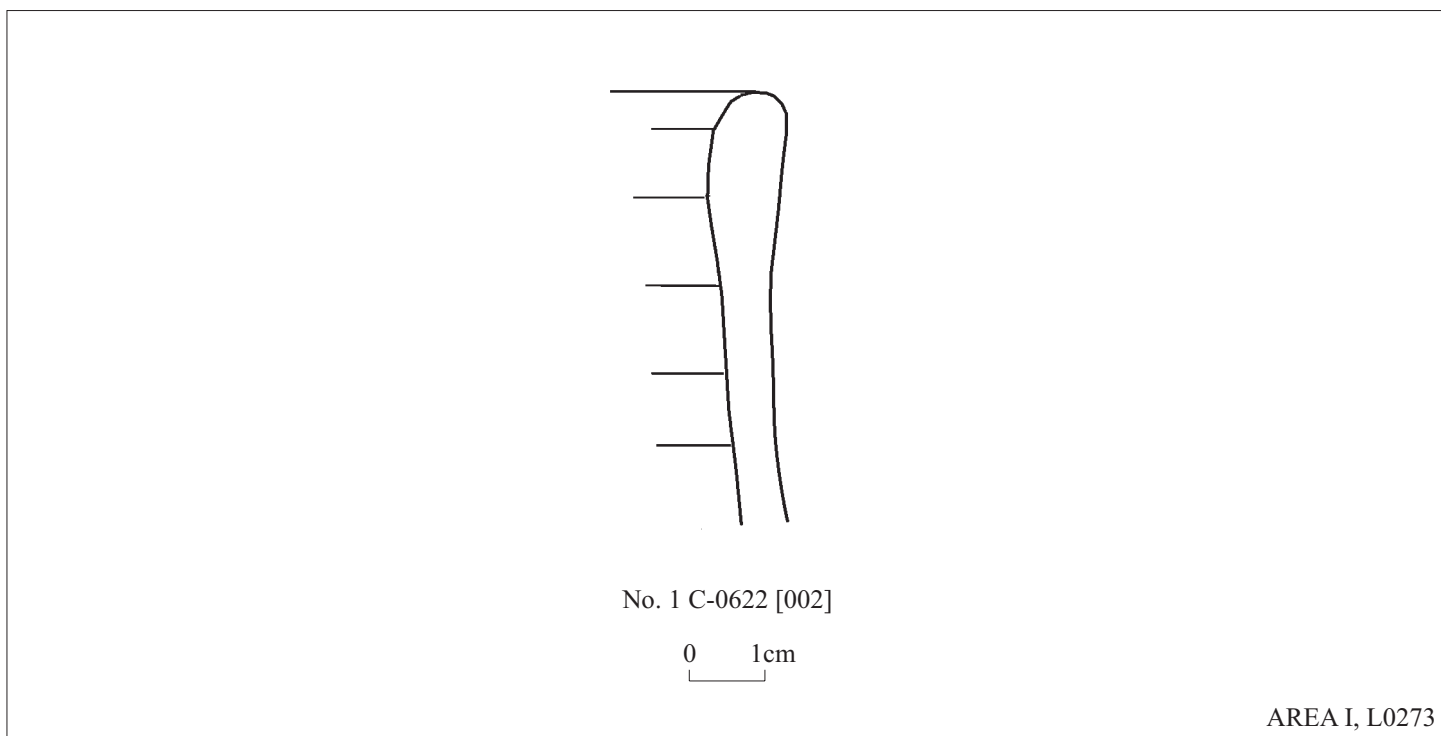


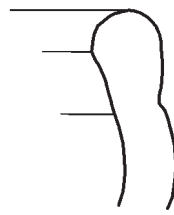
Fig. 12



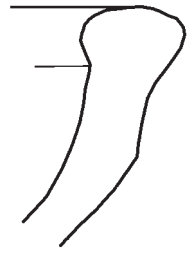
No. 1 C-0635 [013]



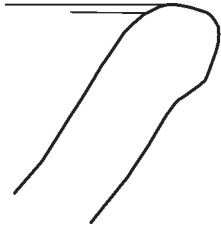
No. 3 C-0635 [009]



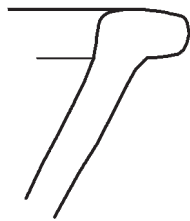
No. 4 C-0619 [008]



No. 5 C-0416 [006]



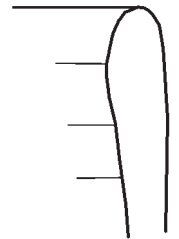
No. 7 C-0619 [001]



No. 8 C-0635 [020]



No. 9 C-0416 [010]



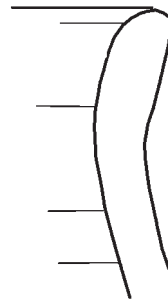
No. 11 C-0619 [003]



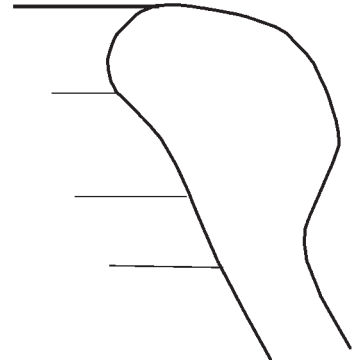
No. 13 C-0635 [017]



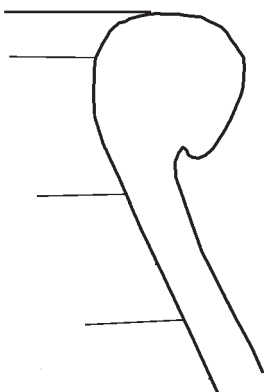
No. 14 C-0635 [021]



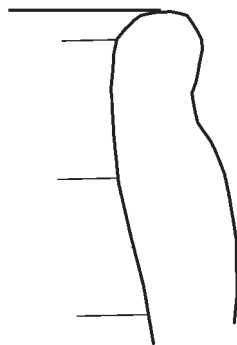
No. 15 C-0635 [004]



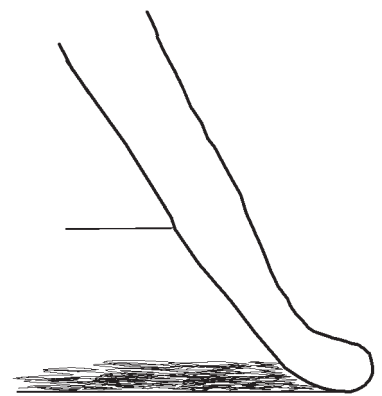
No. 17 C-0416 [021]



No. 18 C-0416 [020]



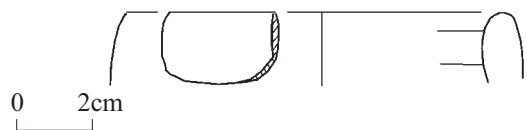
No. 19 C-0635 [014]



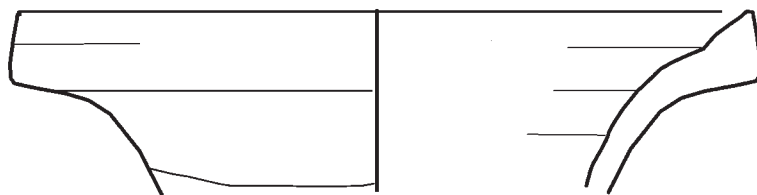
No. 22 C-0635 [005]

0 1cm

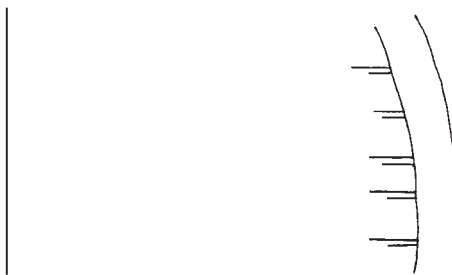
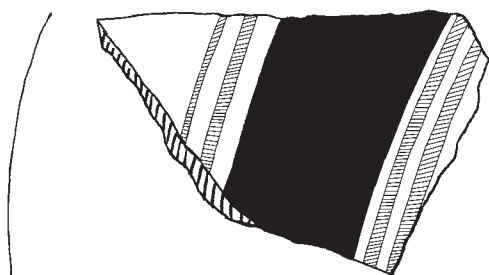
Fig.13:1



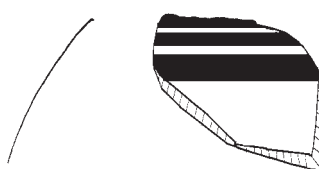
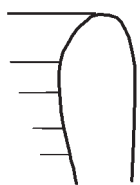
No. 26 P2006A



No. 27 P0806A

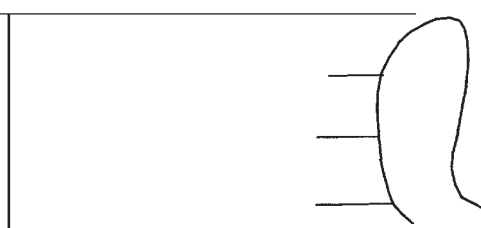
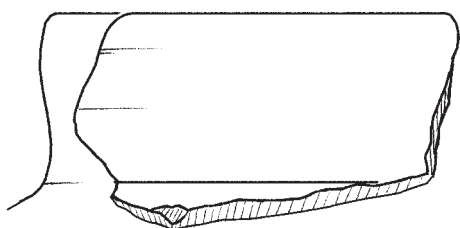


No. 28 P0787A

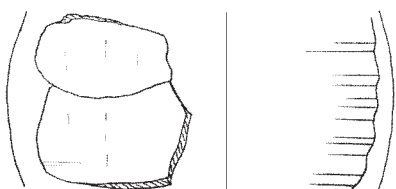


No. 29 C-0635 [028]

No. 38 P0798A



No. 39 P1191A

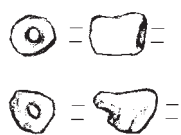


No. 47 F0721A

No. 41 P0710A



Fig. 13:2

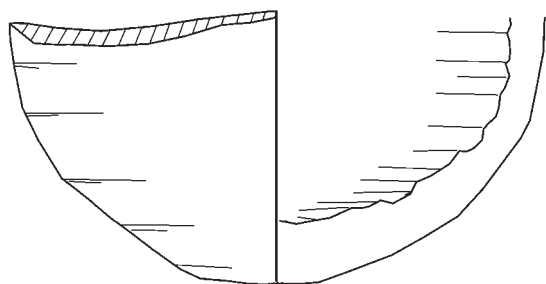


No. 1 F0039A



AREA I, L0012 = L0209

Fig. 14



No. 1 P0058A

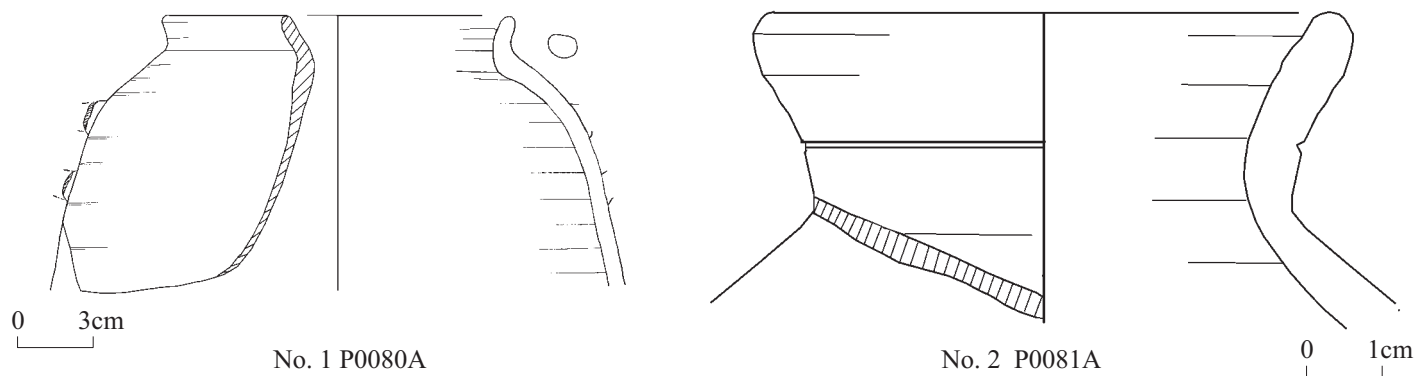


No. 2 C-0212 [001]



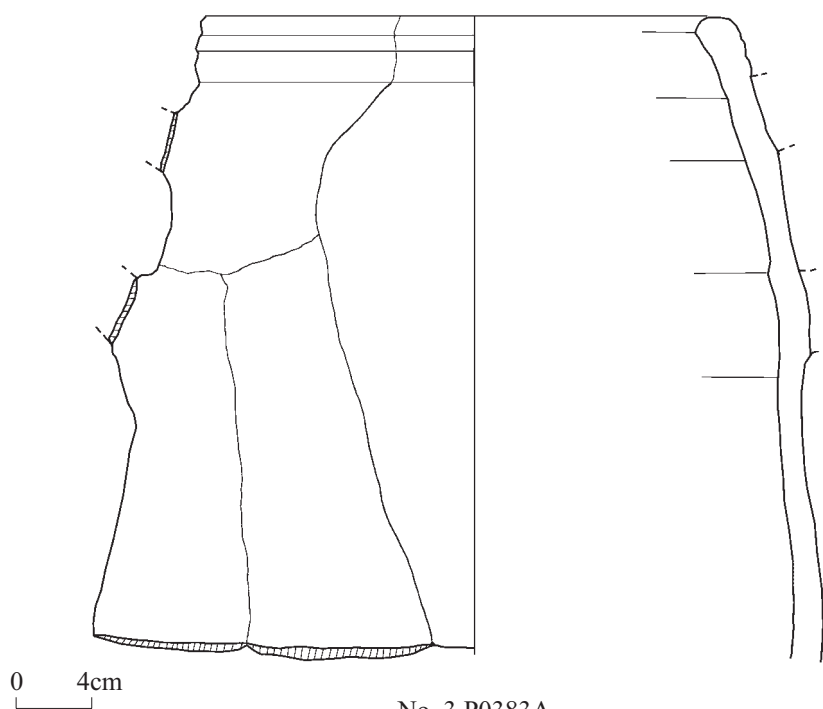
AREA I, L0014 = L0059 = L0081

Fig. 15

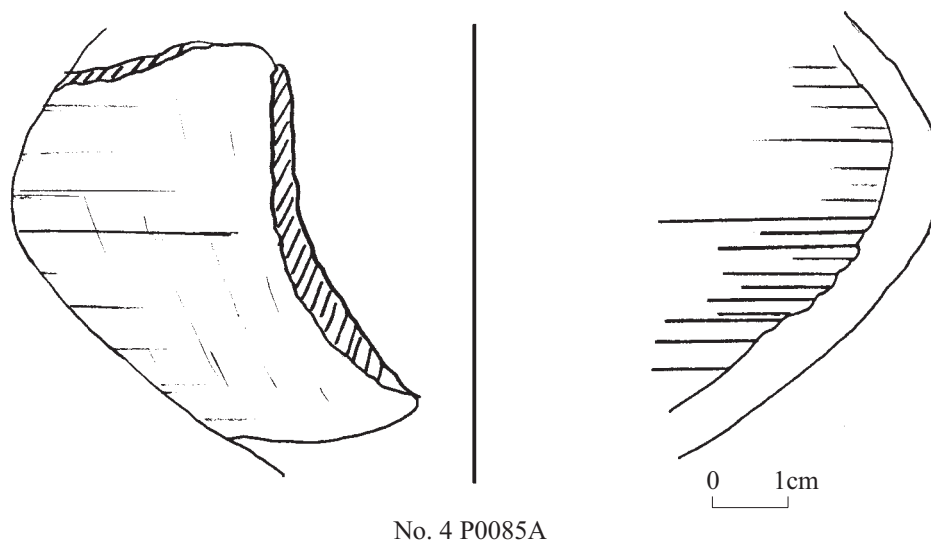


No. 1 P0080A

No. 2 P0081A



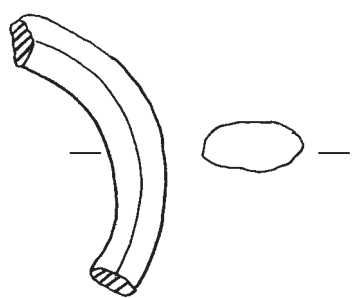
No. 3 P0383A



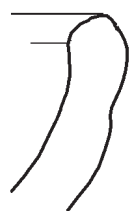
No. 4 P0085A

AREA I, L0015 = L0023

Fig. 16



No. 1 P0388A



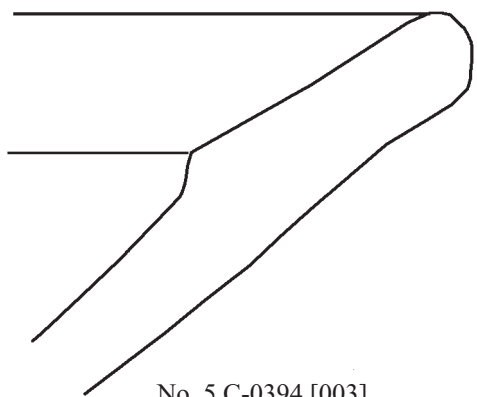
No. 2 C-0038 [001]



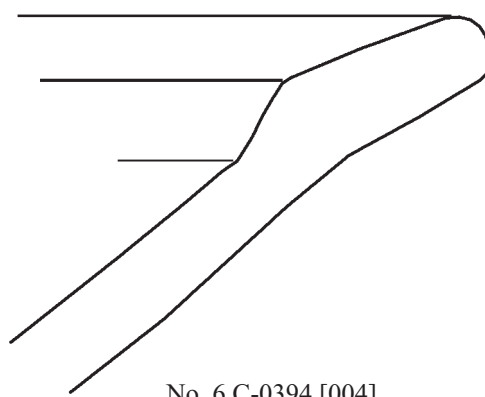
No. 3 C-0394 [008]



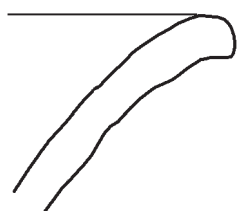
No. 4 C-0394 [008]



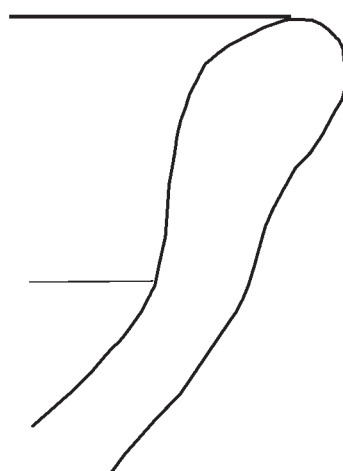
No. 5 C-0394 [003]



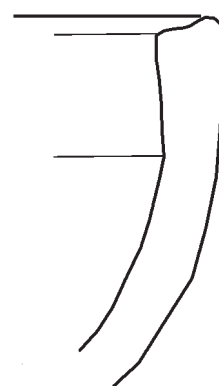
No. 6 C-0394 [004]



No. 7 C-0394 [013]



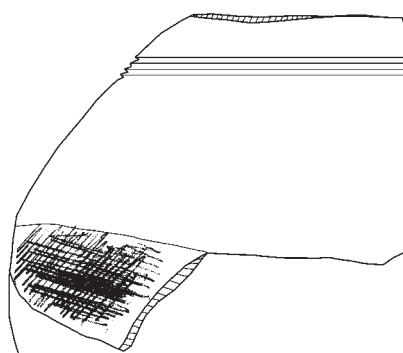
No. 8 C-0512 (2) [004]



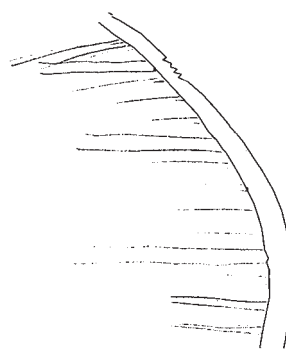
No. 9 C-0512 (2) [005]

0 1cm

0 3cm

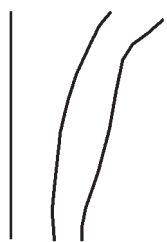


No.10 P1205A



AREA I, L0016 = L0183

Fig. 17:1



No. 11 C-0512 (2) [009]



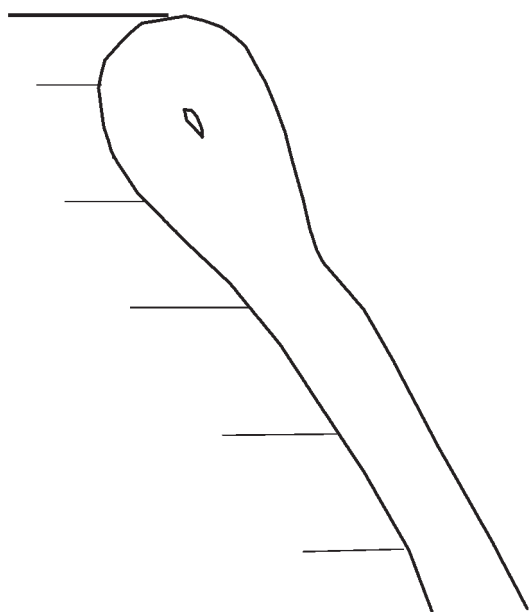
No. 13 C-0035 [006]



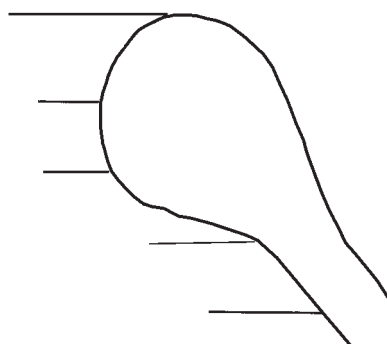
No. 14 C-0394 [007]



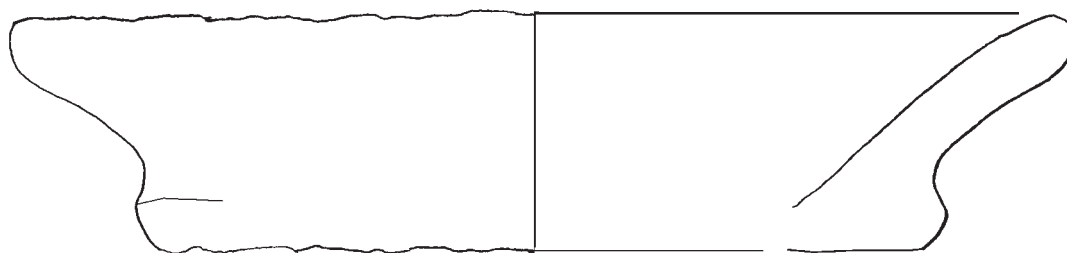
No. 15 C-0035 [008]



No. 18 C-0512 (2) [002]

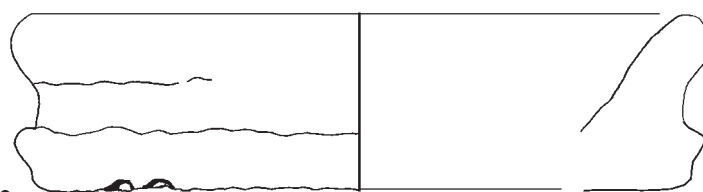


No. 19 C-0512 (2) [008]



No. 21 P0572A

0 1cm

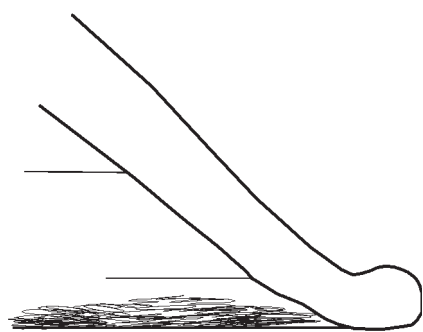


0 2cm

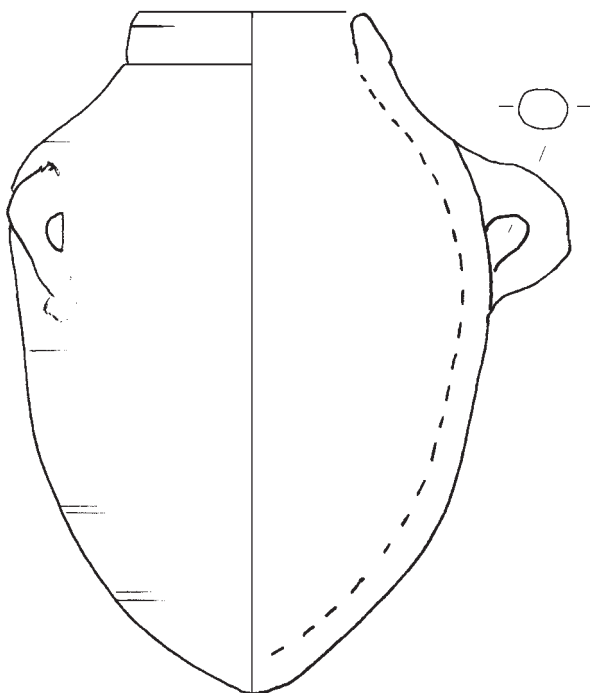
No. 22 P089A

AREA I, L0016 = L0183

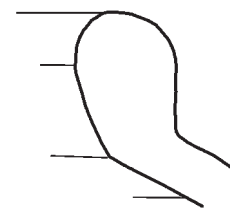
Fig. 17:2



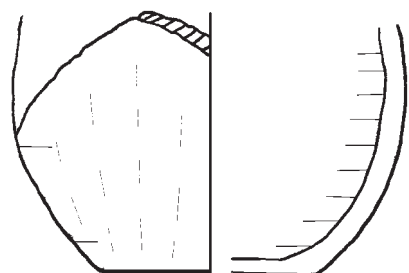
No. 23 C-0512 (2) [006]



No. 26 P0625



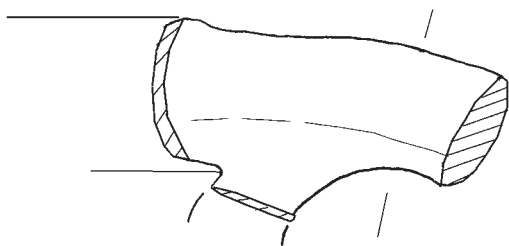
No. 28 C-0394 [012]



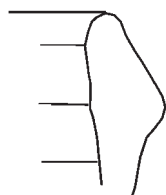
No. 32 P0040A



No. 33 C-0035 (2) [001]



No. 34 P0859A

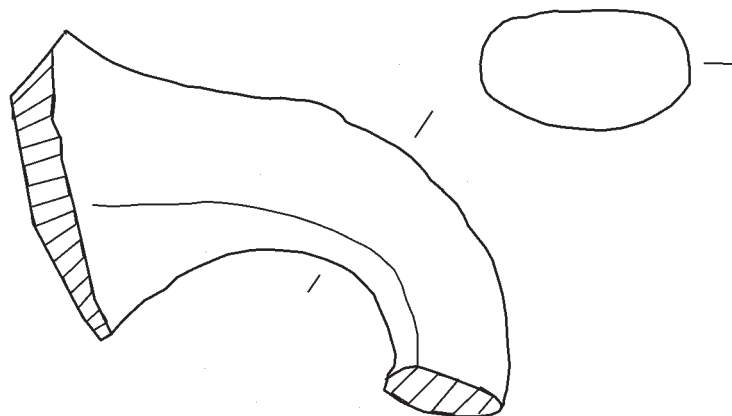


No. 39 C-0395 [013]

0 1cm

AREA I, L0016 = L0183

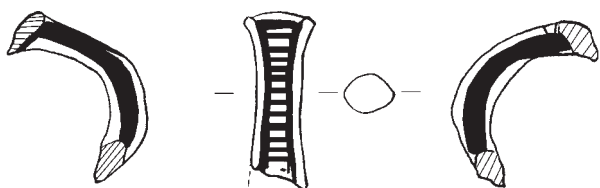
Fig. 17:3



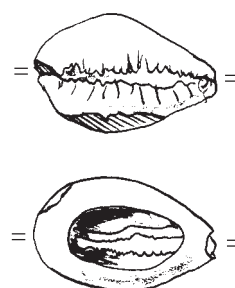
No. 43 P1283A



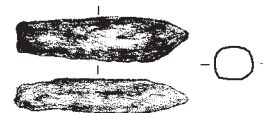
No. 53 P0521A



No. 58 P0045A



No. 62 F0208



No. 65 F0298

0 1cm

AREA I, L0016 = L0183

Fig. 17:4

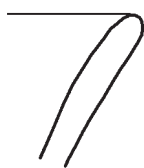


No. 61 F0205

AREA I, L0016 = L0183



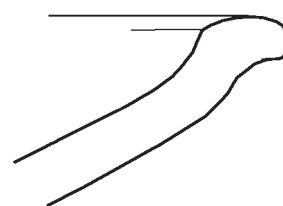
No. 1 C-0044 [033]



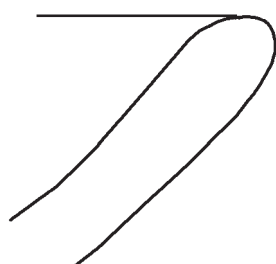
No. 2 C-0044 [007]



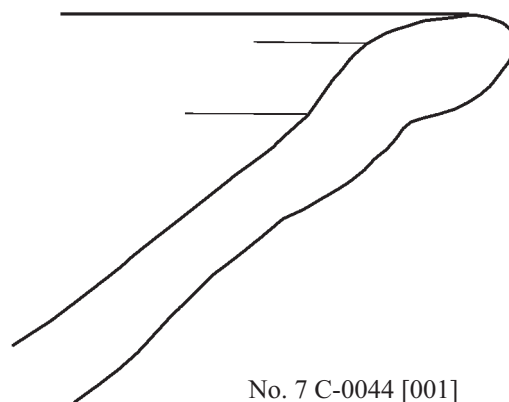
No. 3 C-0046 [006]



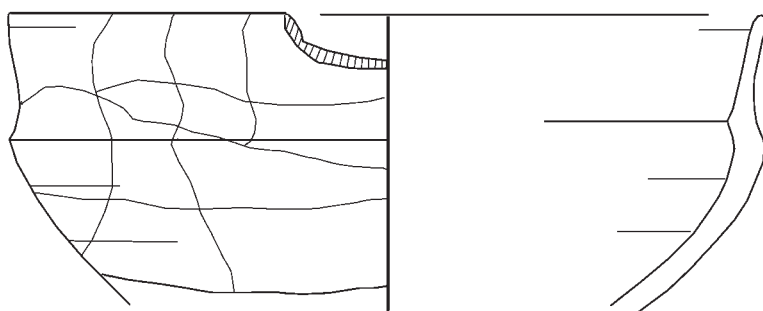
No. 4 C-0044 [023]



No. 6 C-0036 [003]



No. 7 C-0044 [001]



No. 8 P0120A



No. 9 C-0042 [001]



No. 10 C-0044 [031]

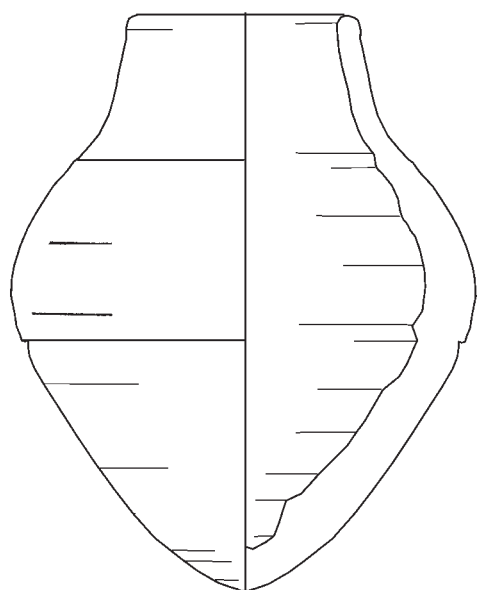


No. 11 C-0044 [0321]

0 1cm

AREA I, L0017

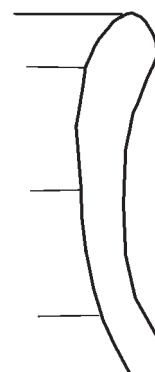
Fig. 18:1



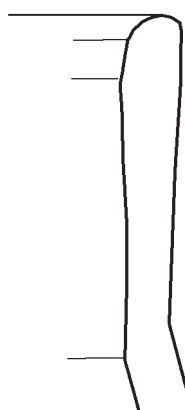
No. 13 P0052



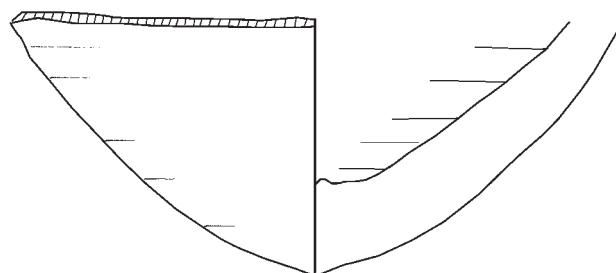
No. 14 C-0044 [030]



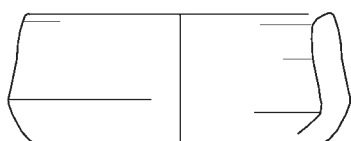
No. 15 C-0046 [001]



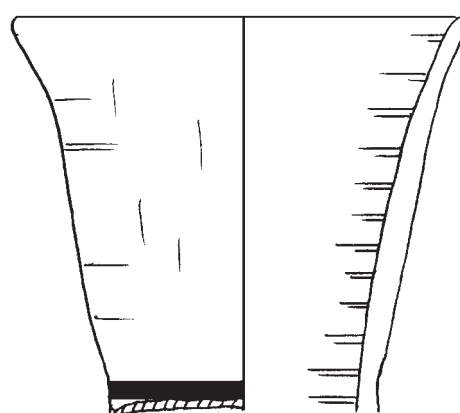
No. 16 C-0044 [027]



No. 17 P0122A



No. 20 C-0046 (2) [002]

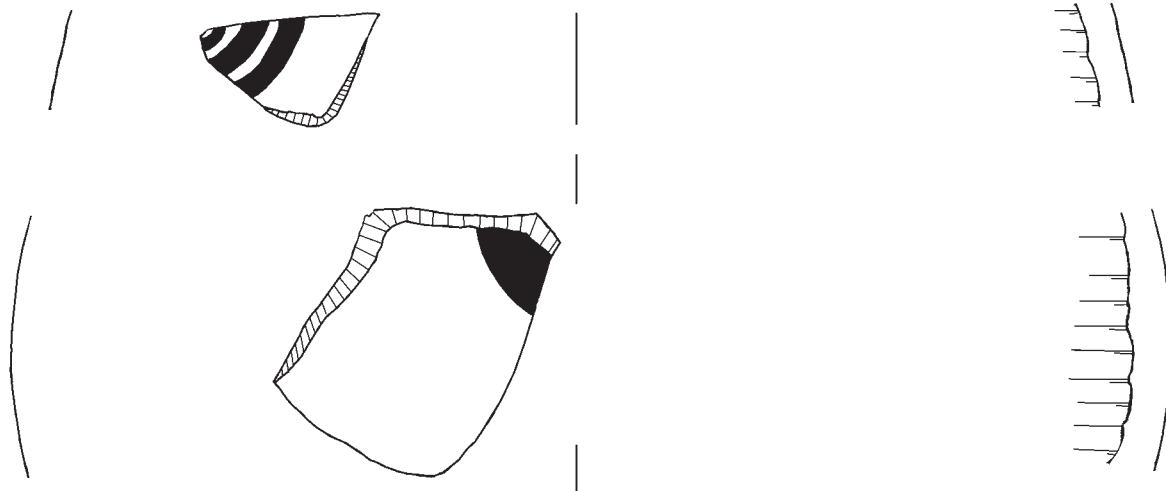


No. 21 P0051A

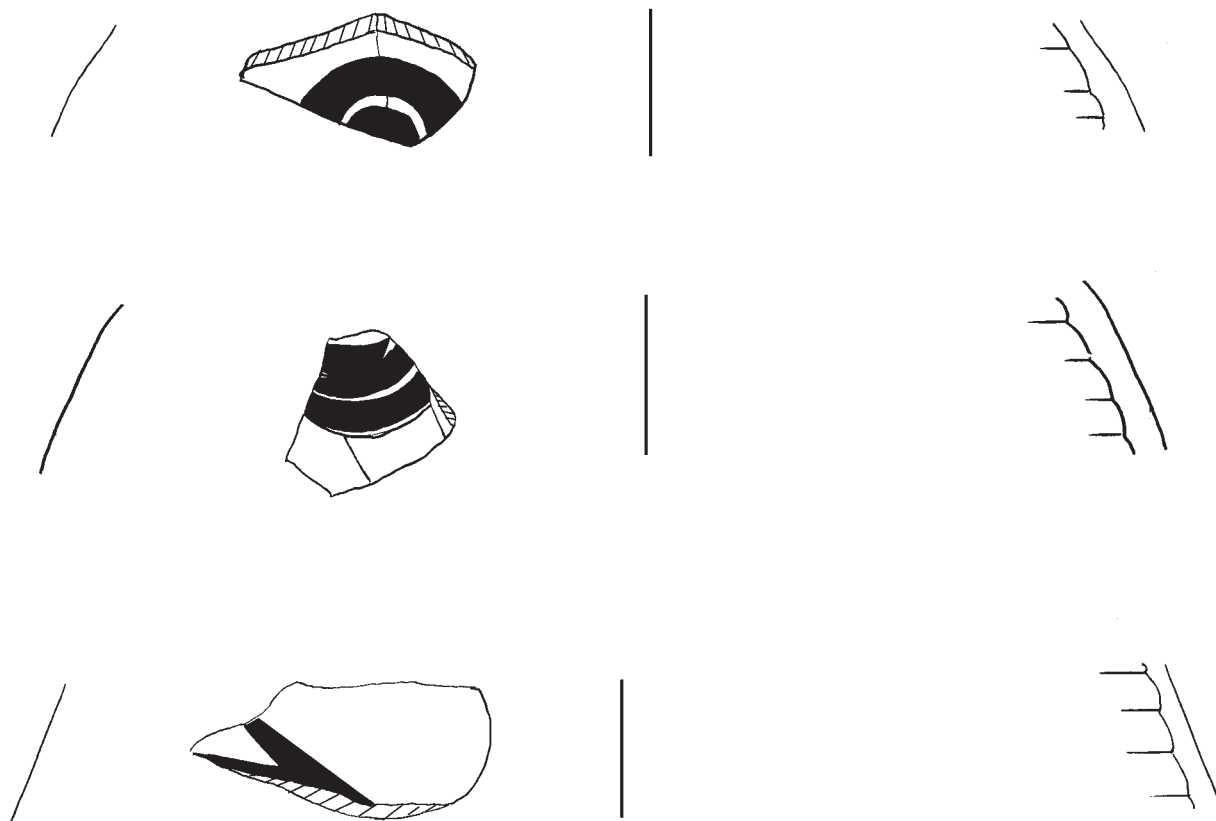
0 1cm

AREA I, L0017

Fig. 18:2



No. 25 P1193A

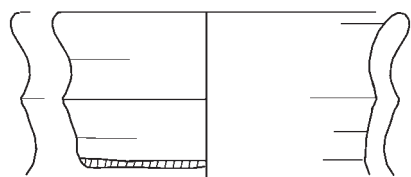


No. 26 P0093A₁₋₂

0 1cm

AREA I, L0017

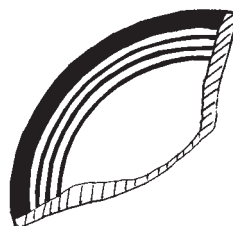
Fig. 18:3



No. 47 P0119A



No. 49 P0060A



No. 48 P0063A

0 1cm

AREA I, L0017

Fig. 18:4



No. 51 F1000

6



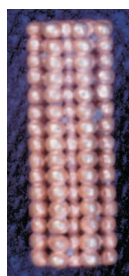
7



No. 52 F0009



8



No. 53 F0008

9

AREA I, L0017

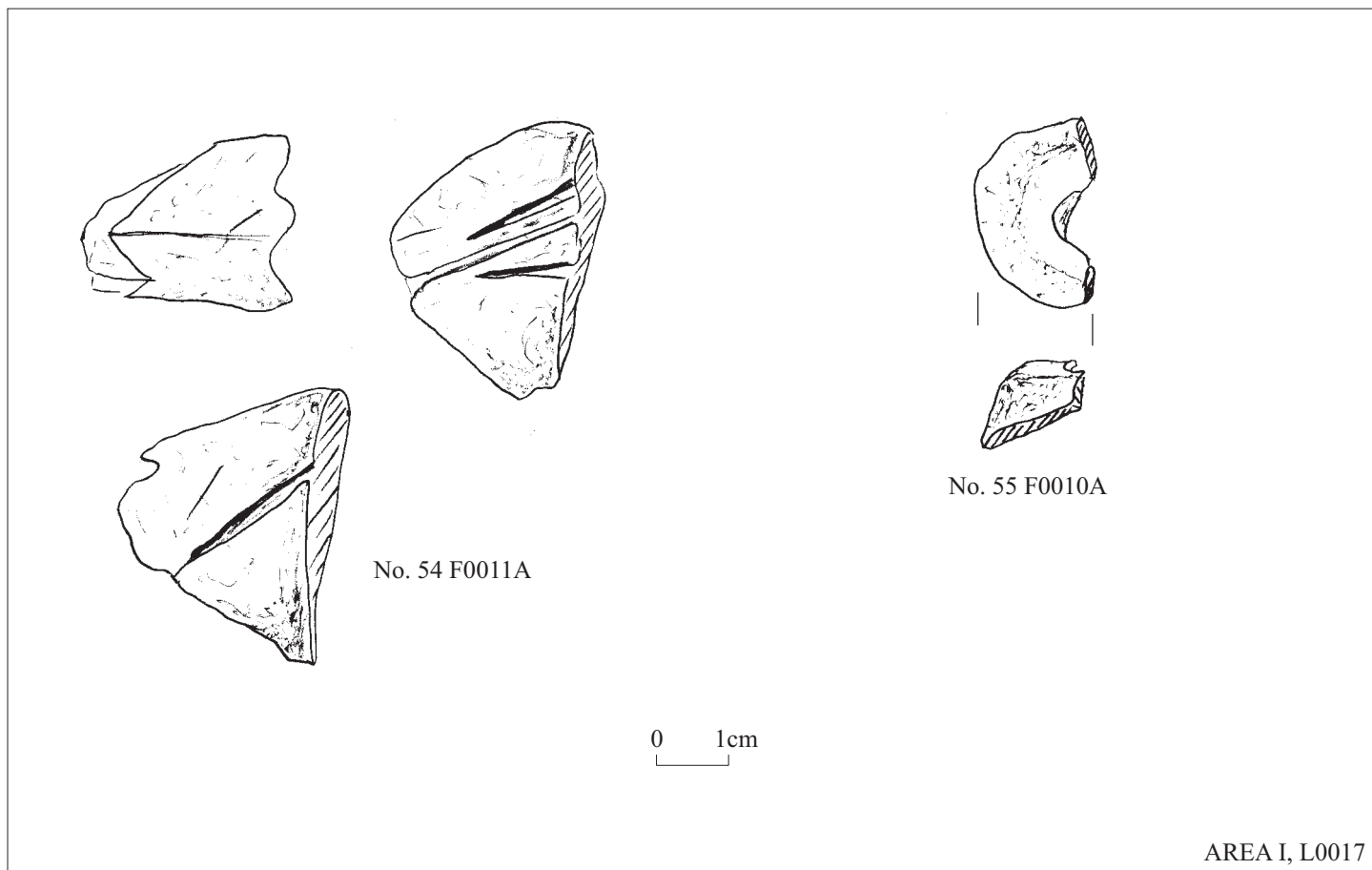


Fig. 18:5

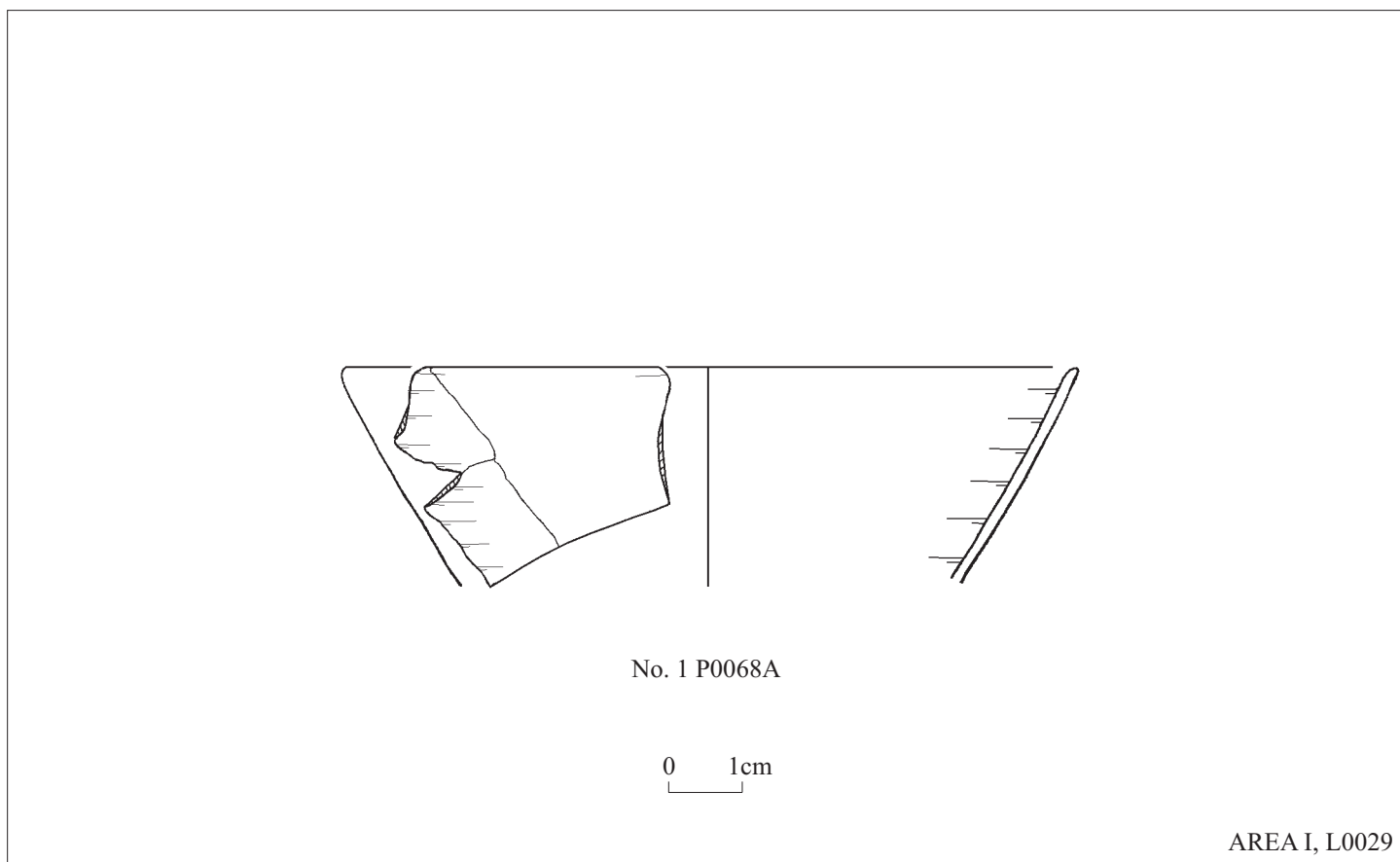


Fig. 19

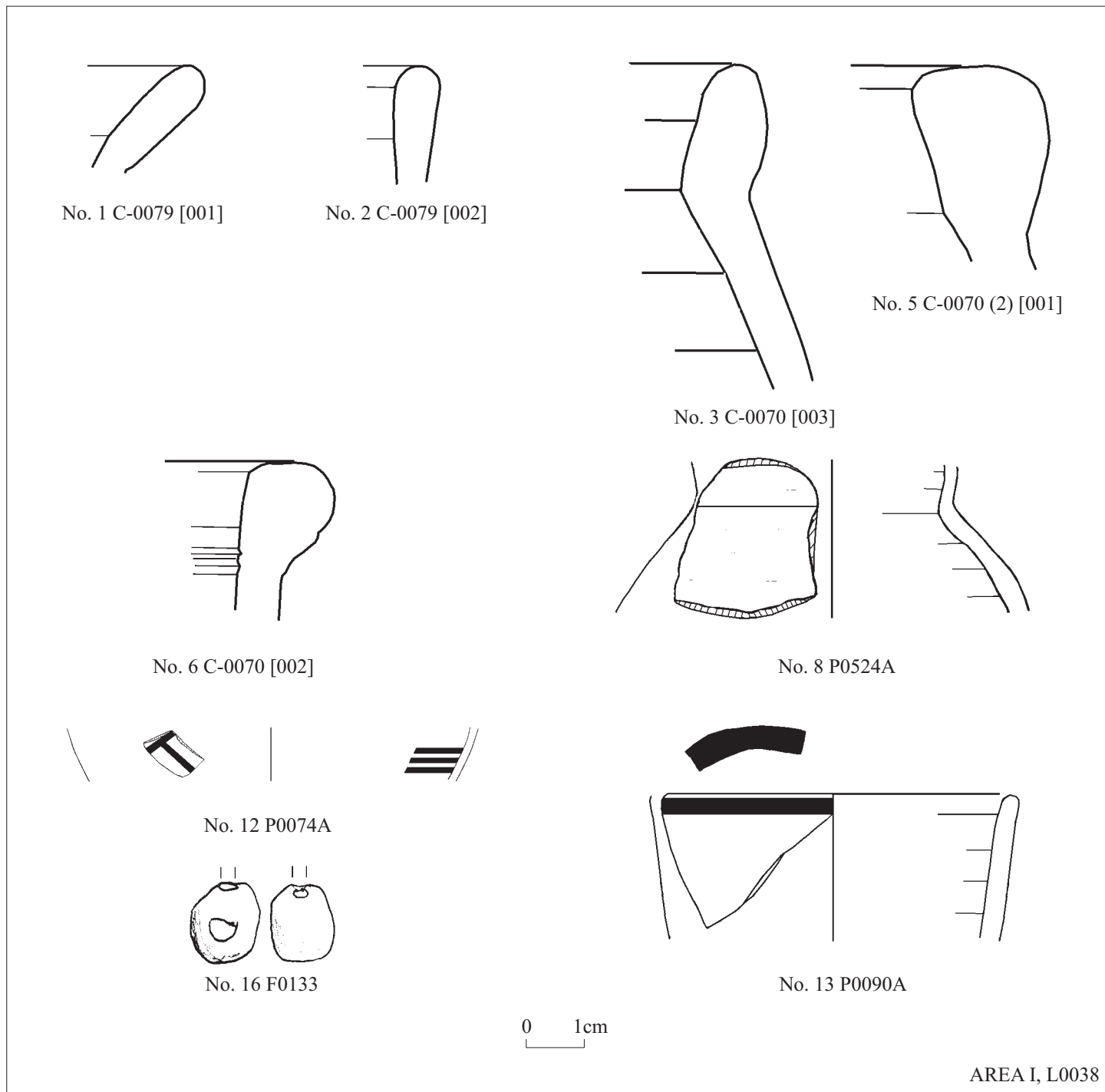
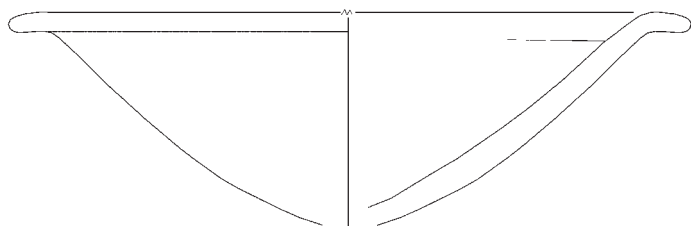
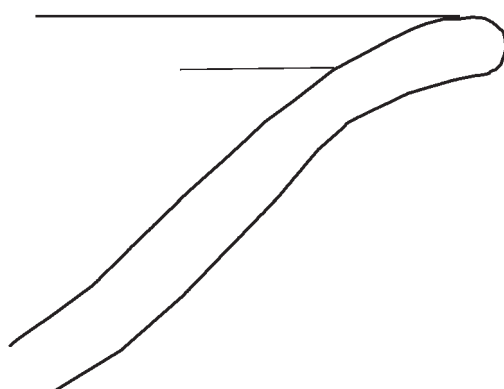


Fig. 20

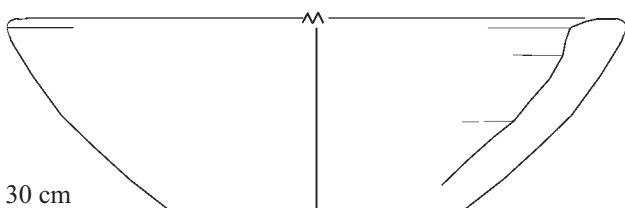




No. 2 C-0429 (4) [002]

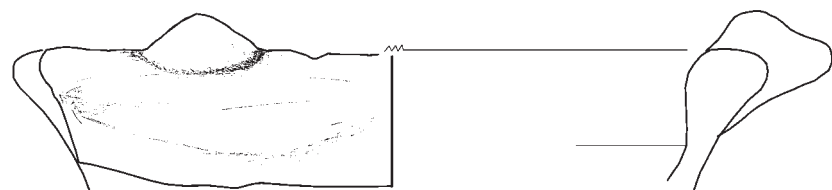
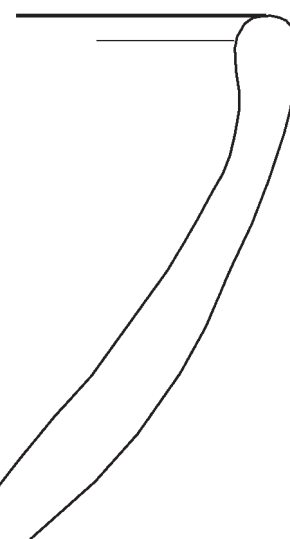


No. 3 C-0429 (2) [001]



Rd: 30 cm

No. 4 C-0429 (4) [001]



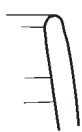
Rd: 44 cm

No. 5 P1013A

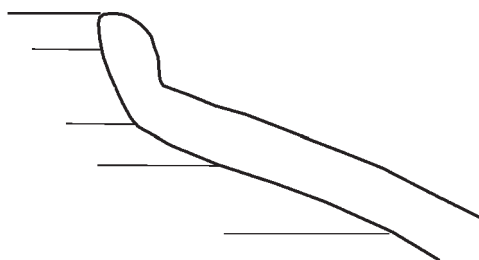
0 2cm

No. 6 C-0429 (2) [003]

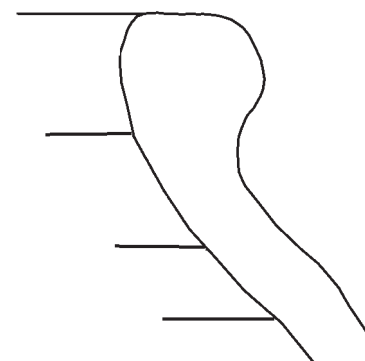
0 1cm



No. 7 C-0429 (2) [005]



No. 8 C-0429 (4) [009]

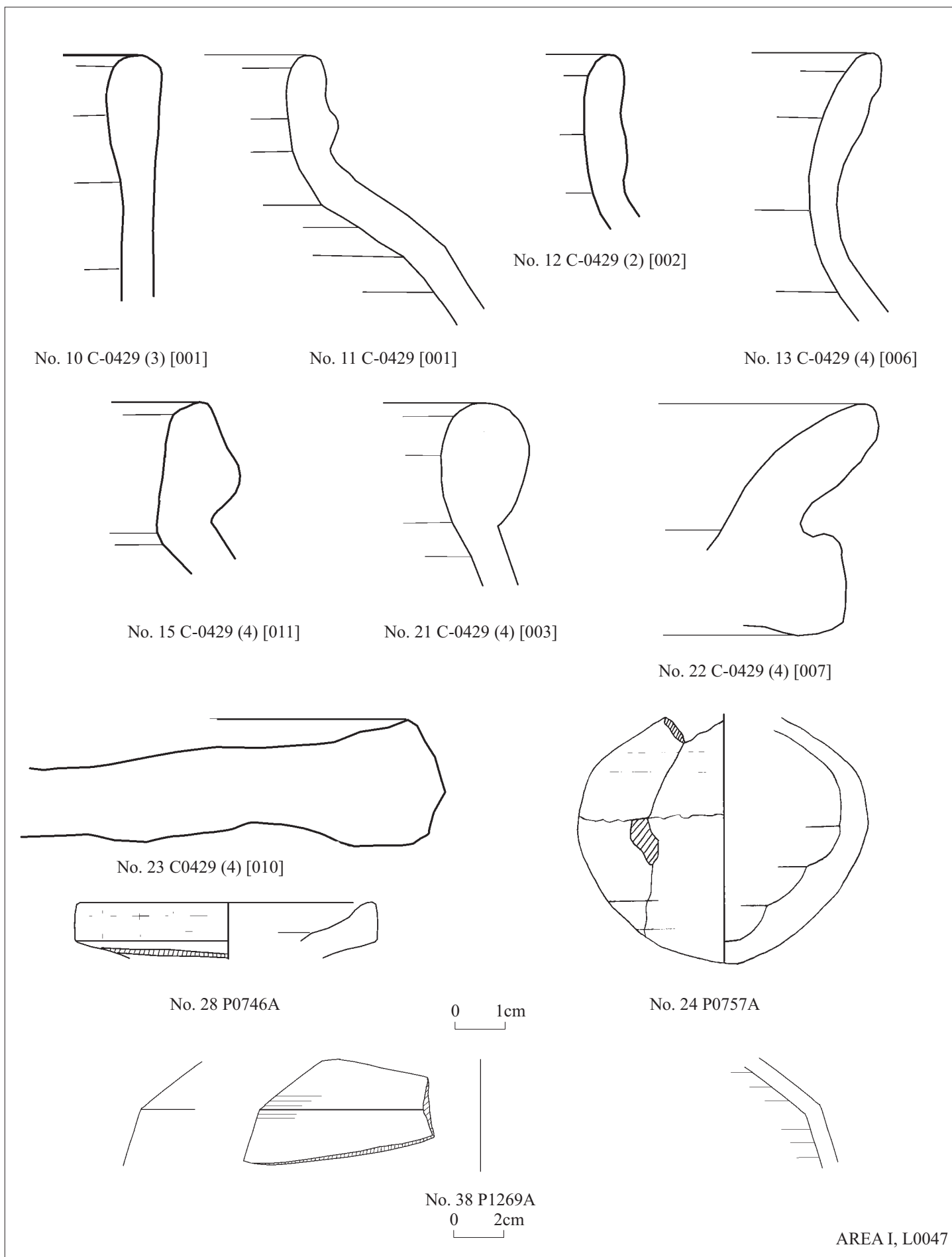


No. 9 C-0429 (4) [008]

0 1cm

AREA I, L0047

Fig. 21:1

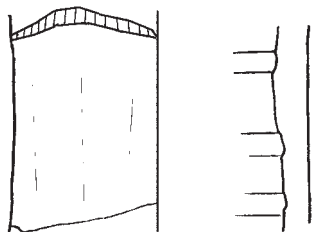


AREA I, L0047

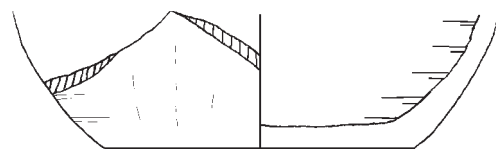
Fig. 21:2



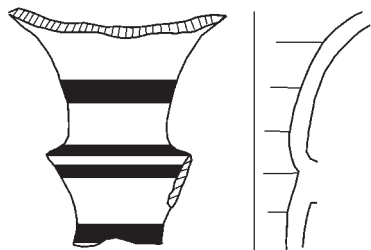
No. 39 P7063A



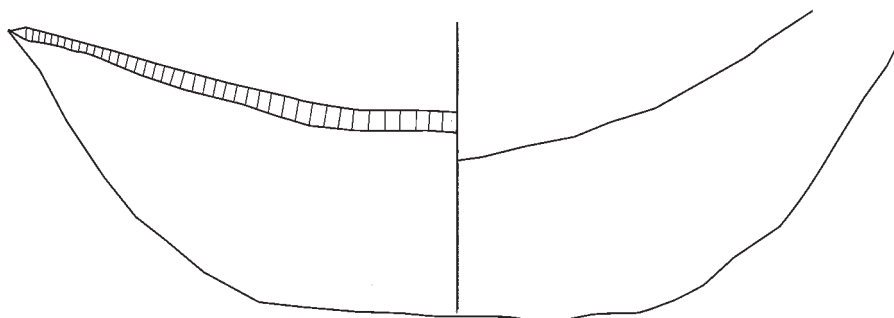
No. 40 P7065A



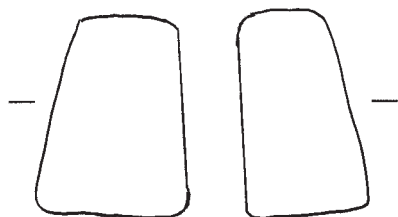
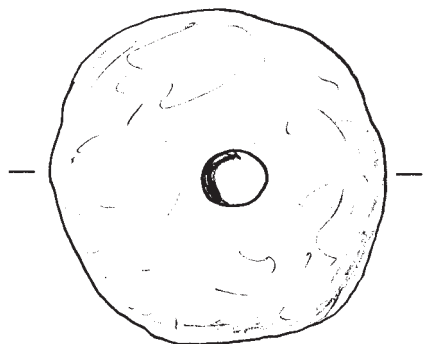
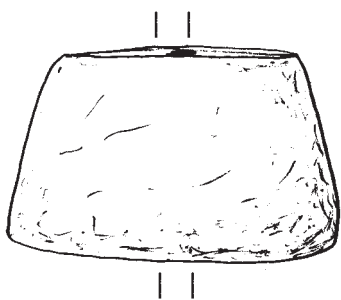
No. 41 P0863A



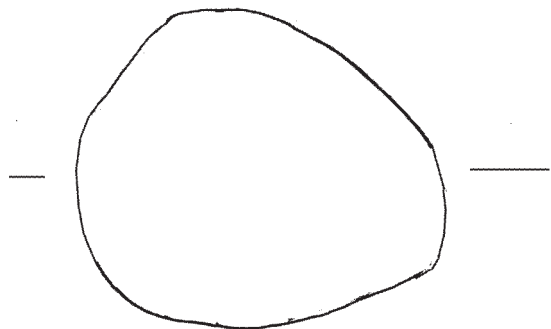
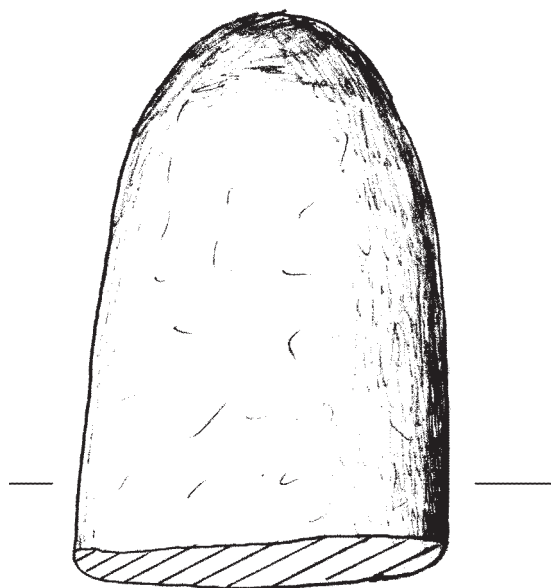
No. 43 P0783A



No. 46 F0569A

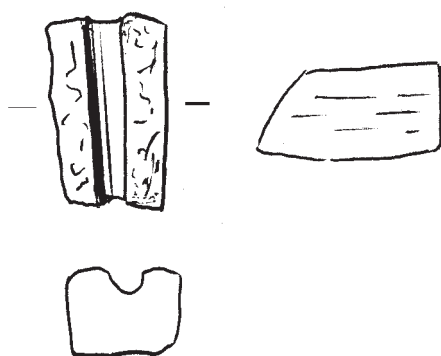


No. 47 F0347



No. 48 F0930A

Fig. 21:3

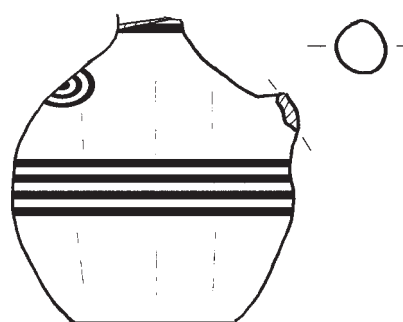


No. 53 F0939A

0 1cm

AREA I, L0047

Fig. 21:4

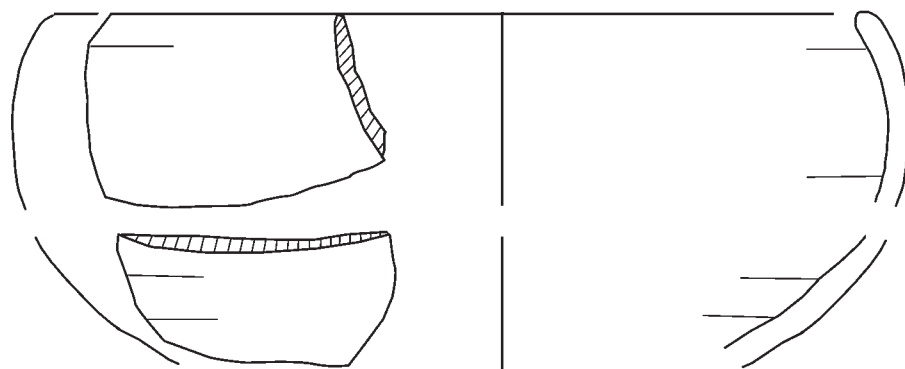


No. 2 P0053B

0 1cm

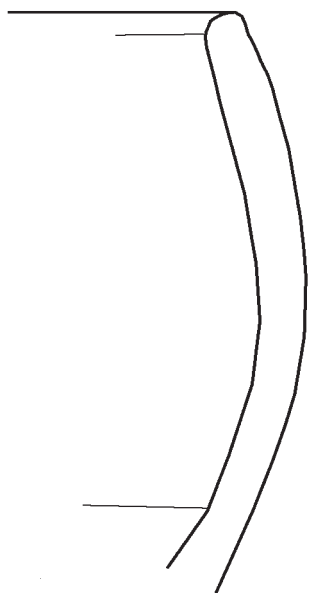
AREA I, L0069

Fig. 22

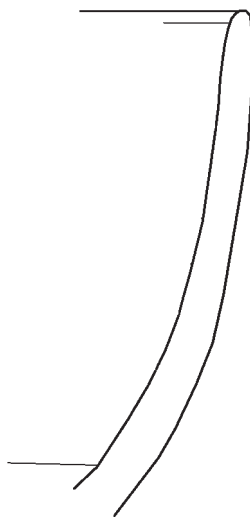


No. 1 P0510A

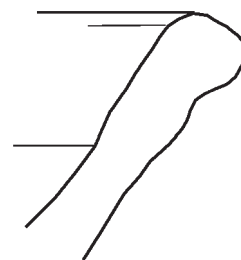
0 2cm



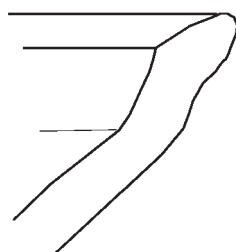
No. 2 C-0281 [001]



No. 3 C-0295 [003]



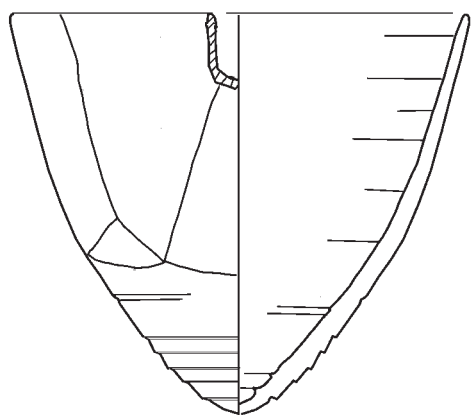
No. 4 C-0020 [006]



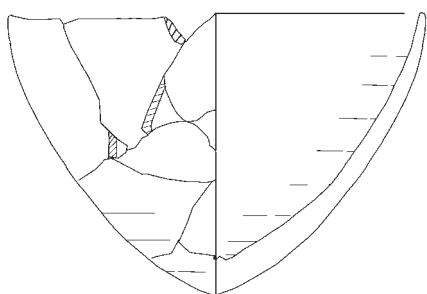
No. 5 C-0295 [002]

0 1cm

Fig. 23:1

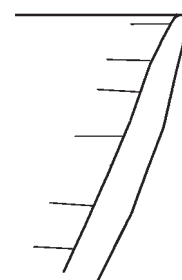


No. 6 P0018A

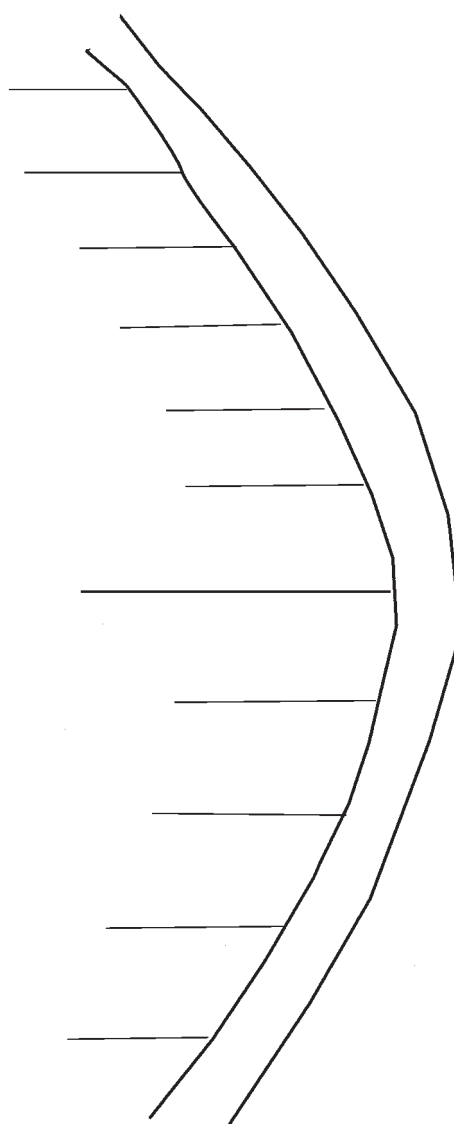


No. 7 P0035A

0 2cm



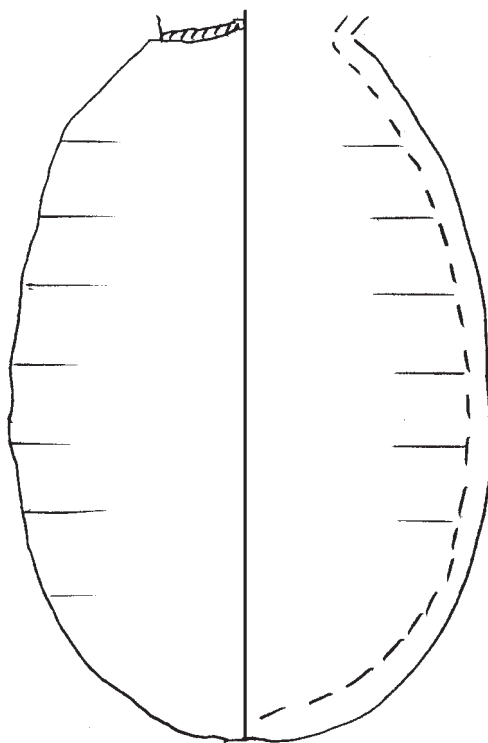
No. 8 C-0154 [004]



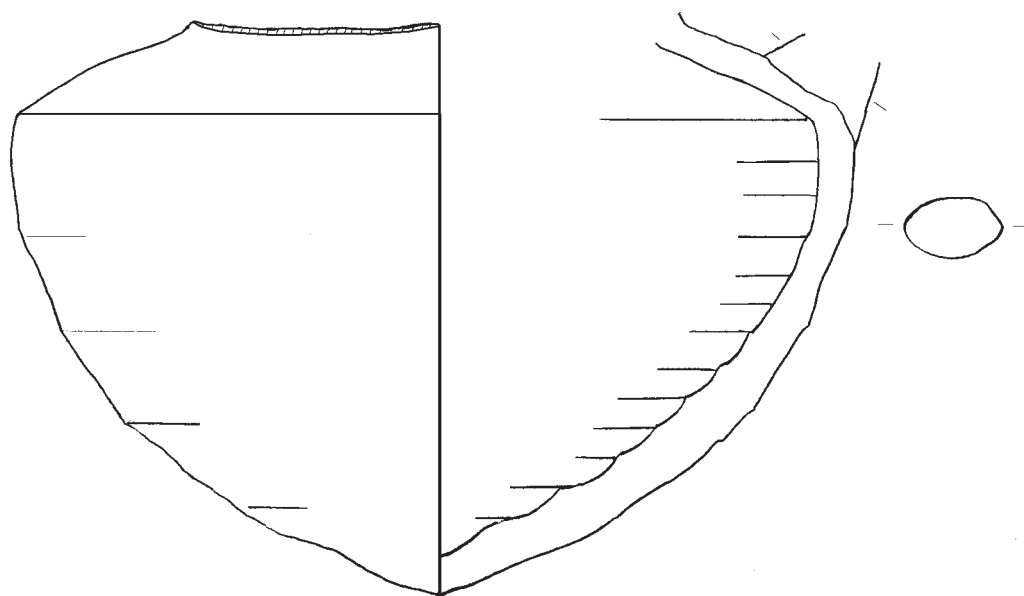
No. 9 C-0154 [001]

0 1cm

AREA I, L0084

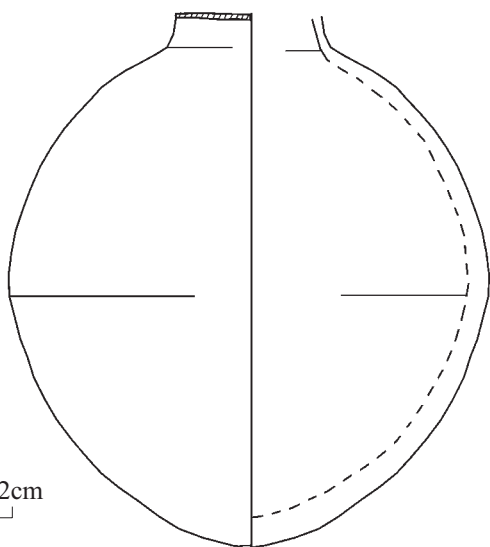


No. 10 P0190B

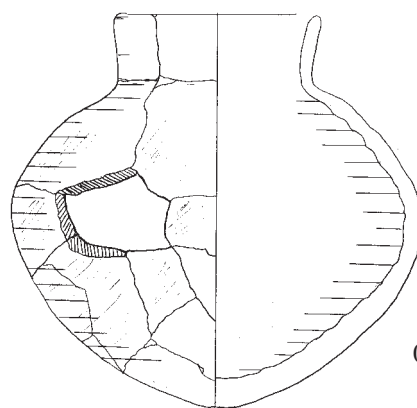


No. 11 P0350A

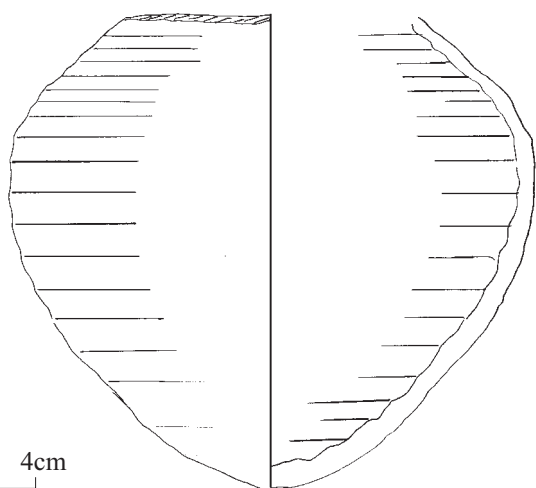
0 1cm



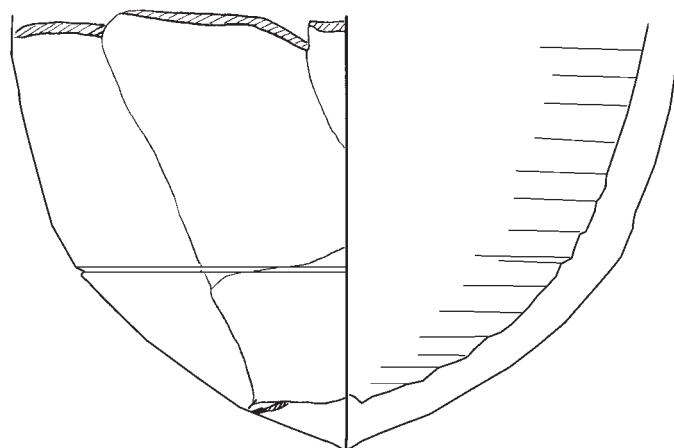
No. 12 P0191A



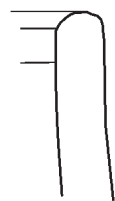
No. 13 P0041A



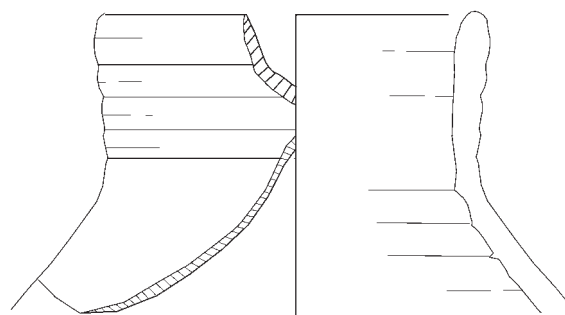
No. 14 P0019A



No. 15 P0562A



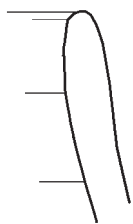
No. 16 C-0154 [003]



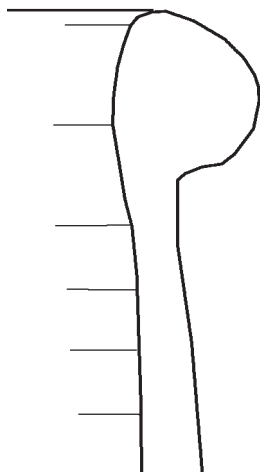
No. 17 P0021A

AREAI, L0084

Fig. 23:4



No. 18 C-0295 [001]

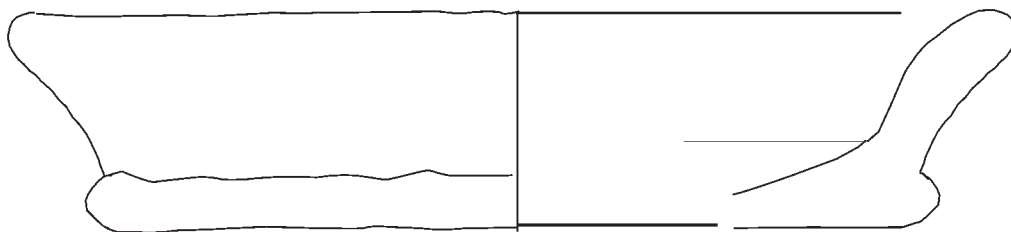


No. 19 C-0295 [005]

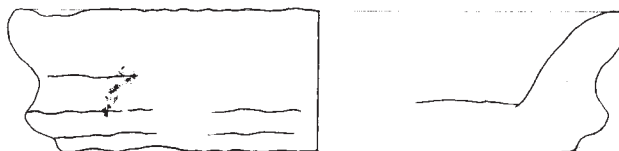


No. 20 C-0200 [002]

0 1cm

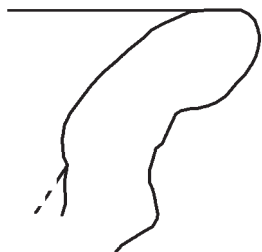


No. 22 P0576A



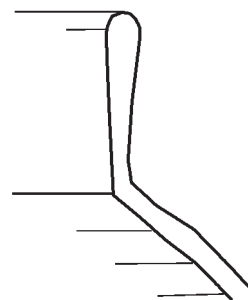
No. 23 P0579A

0 2cm



No. 24 C-0200 [009]

0 1cm



No. 25 C0281 [003]

Fig. 23:5

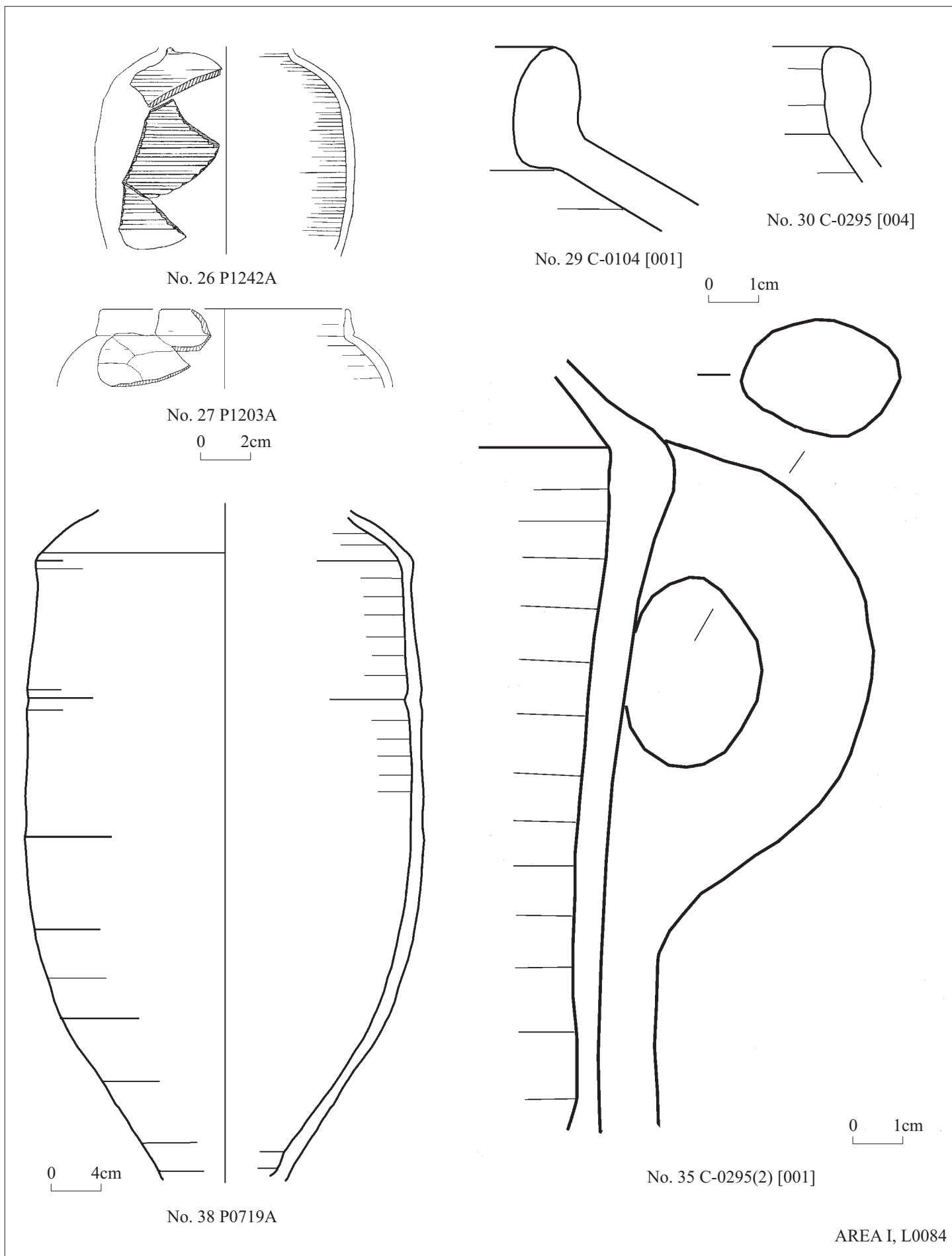


Fig. 23:6

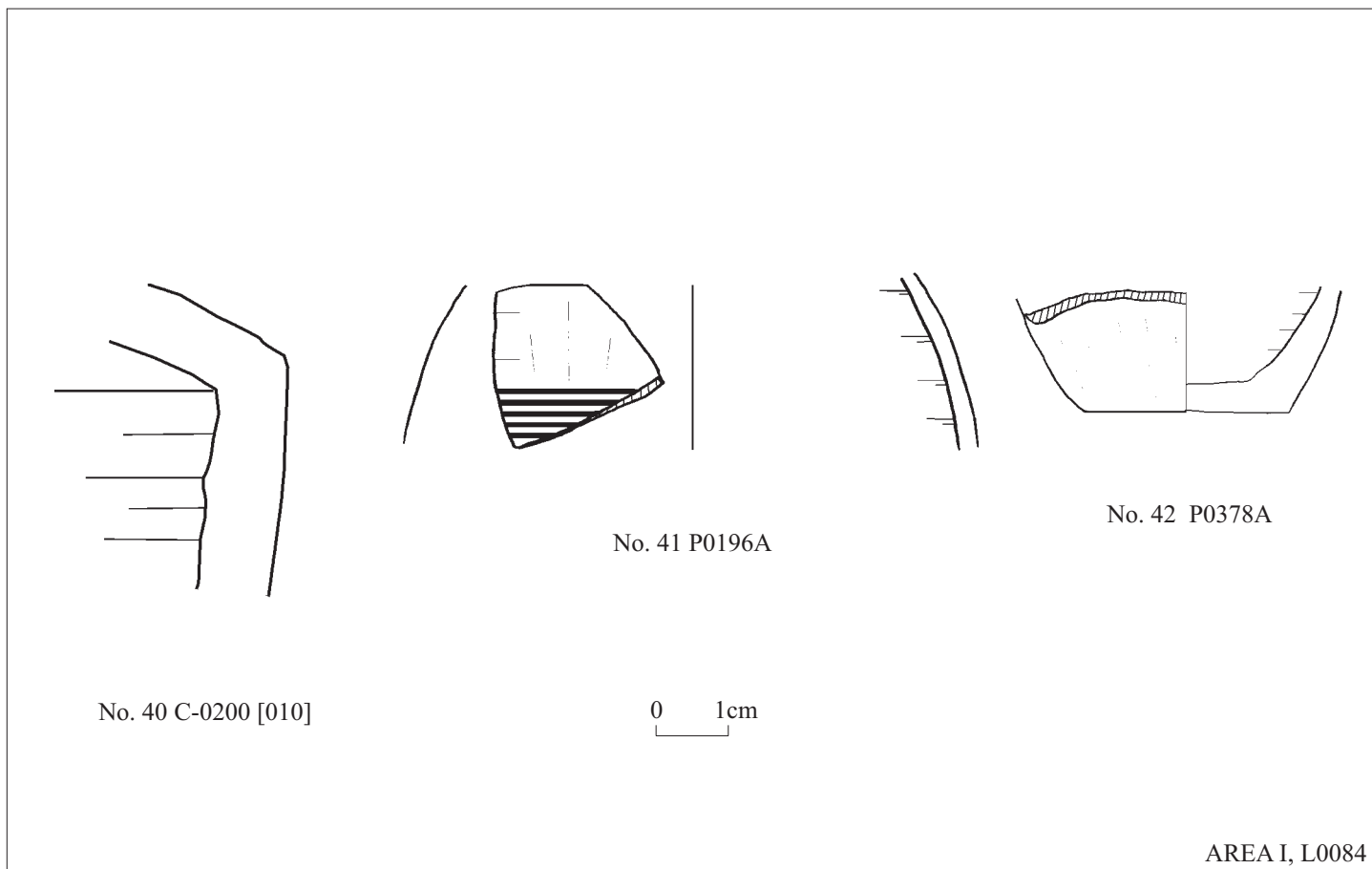


Fig. 23:7

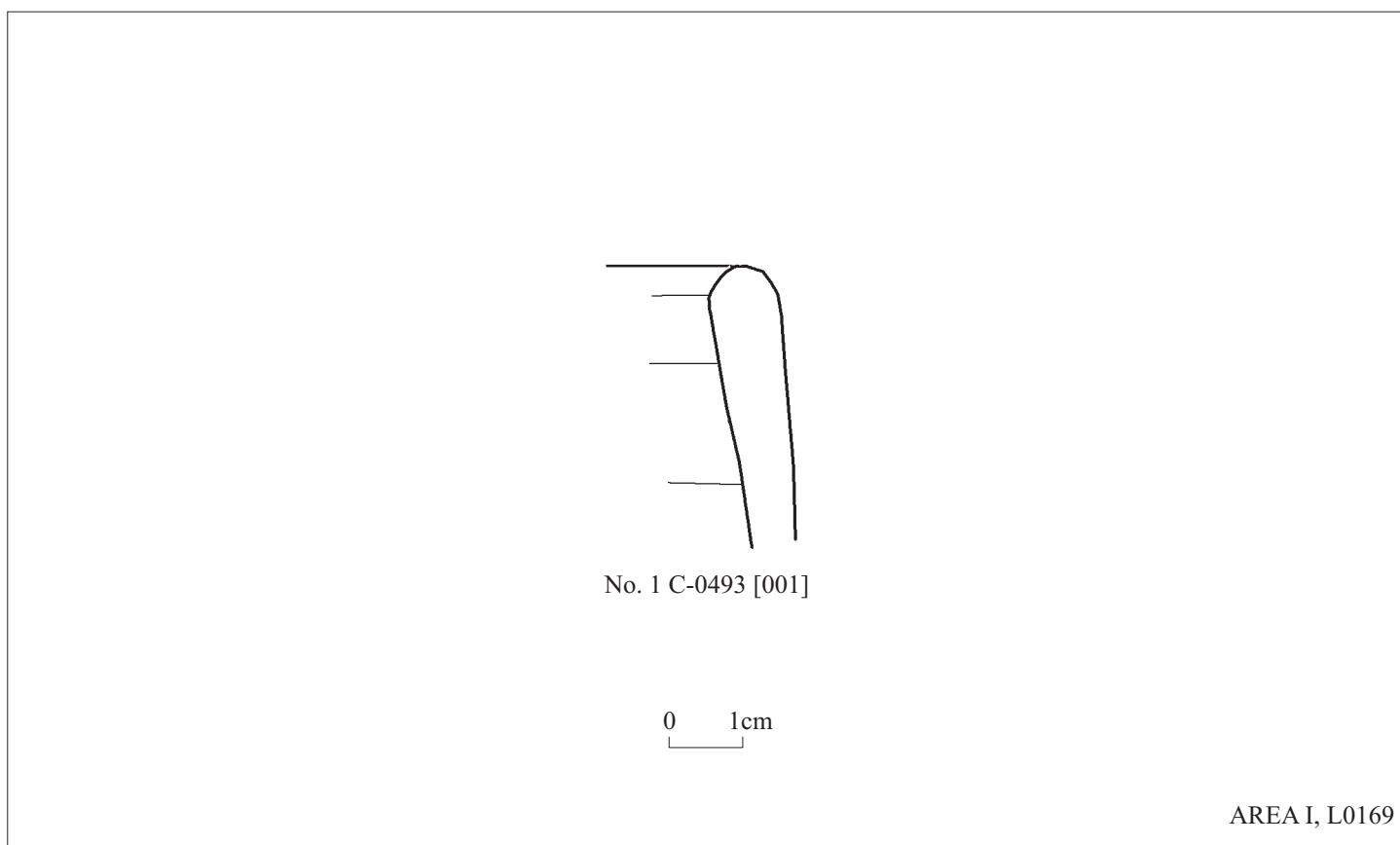
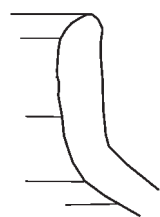
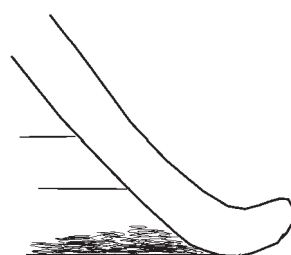


Fig. 24

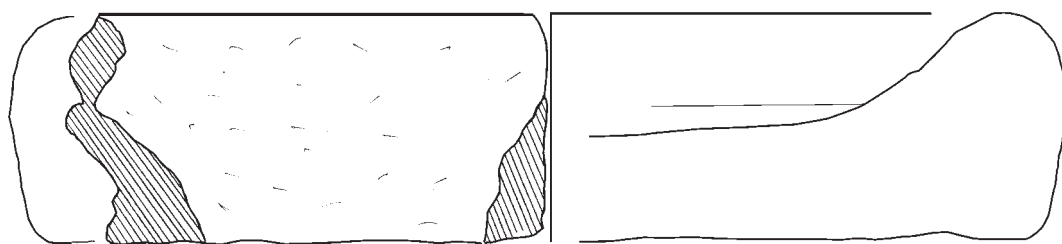


No. 1 C-0444 [001]



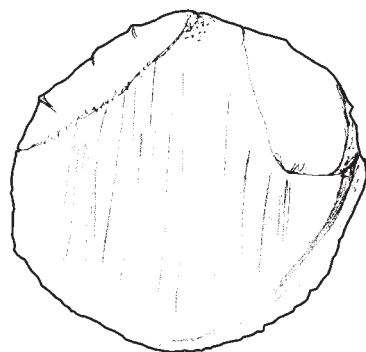
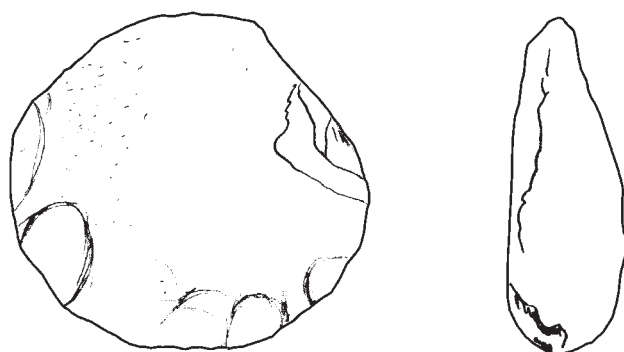
No. 3 C-0444 [003]

0 1cm



D: 56 cm

No. 4 P1011A



No. 11 F1077A

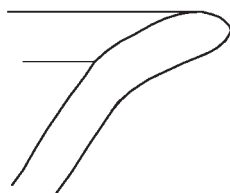
0 2cm

AREA I, L0176

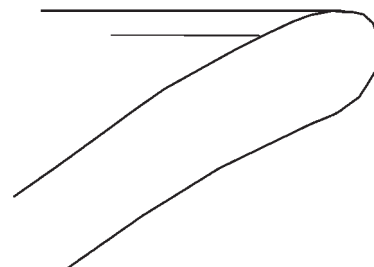
Fig. 25



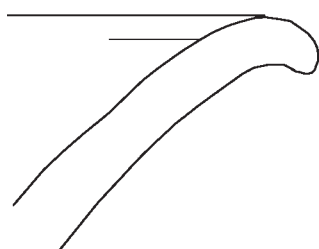
No. 2 C-0312 [001]



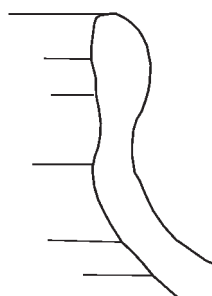
No. 3 C-0312 [002]



No. 4 C-0312 [003]



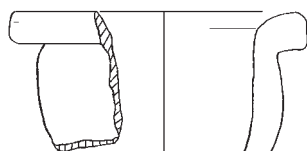
No. 5 C-0398 [004]



No. 6 C-0398 [008]



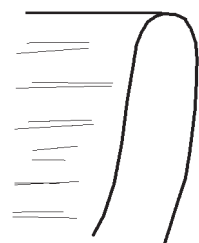
No. 7 C-0398 [002]



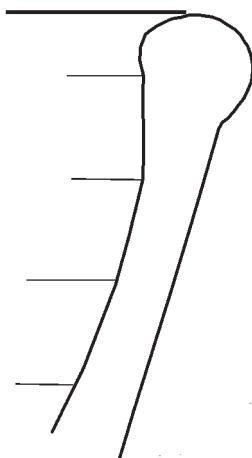
No. 9 P0357A

0 1cm

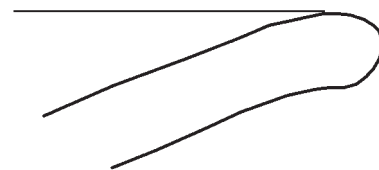
Fig. 26



No. 1 C-0496 (2) [001]



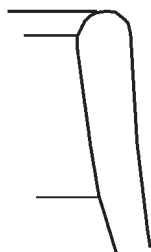
No. 3 C-0496 (2) [003]



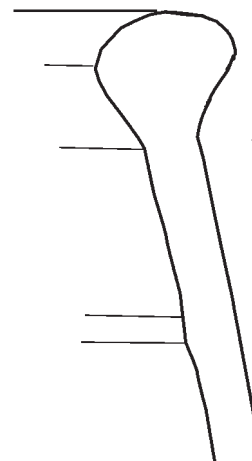
No. 4 C-0496 [002]



No. 5 C-0496 [008]



No. 6 C-0496 [009]



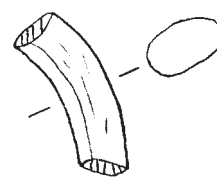
No. 7 C-0496 (2) [002]



No. 8 C-0496 [004]



No. 9 C-0496 [007]



No. 18 P0731A

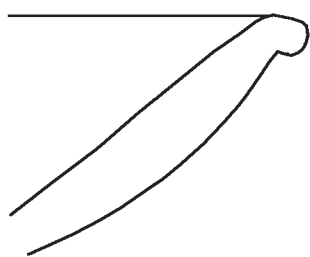


No. 19 P0803A

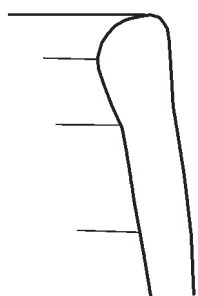
0 1cm

AREA I, L0263 = L0222

Fig. 27



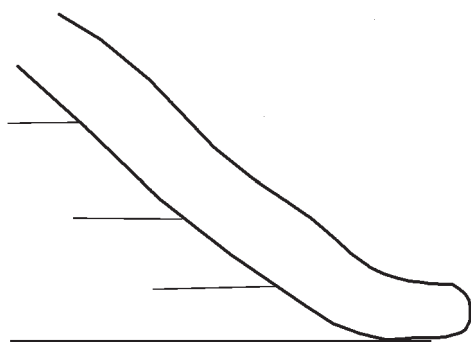
No. 1 C-0463 [001]



No. 3 C-0470 [001]



No. 4 C-0524 [001]

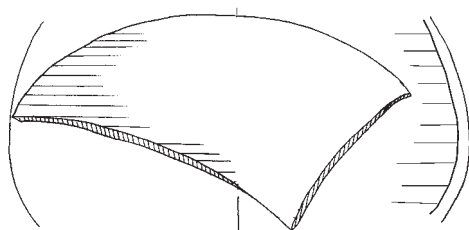


No. 7 C-0470 [002]

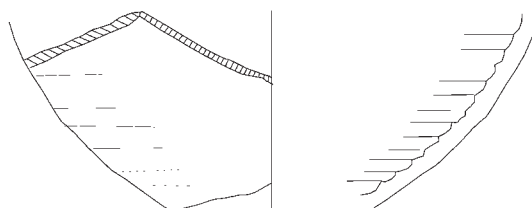


No. 8 C-0524 [003]

0 1cm



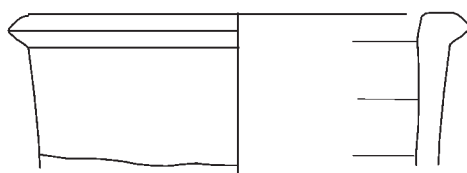
No. 9 P7105A



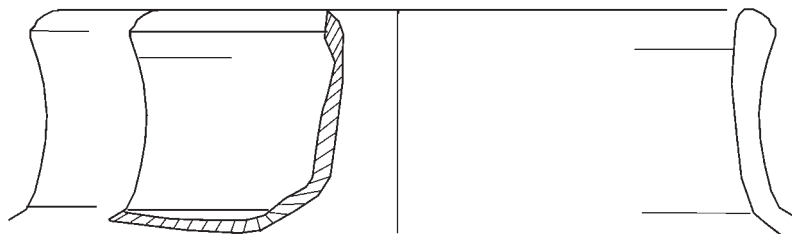
No. 10 P7106A

0 2cm

Fig. 28:1



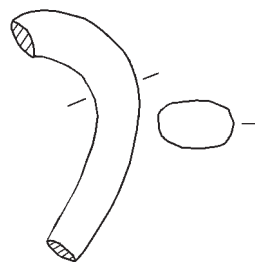
No. 11 P1212A



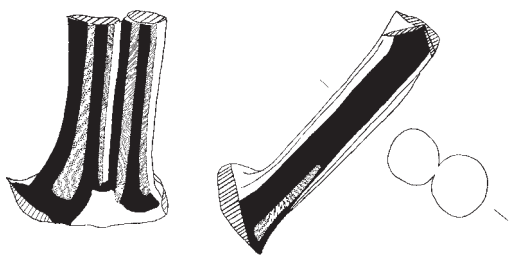
No. 12 P1213A



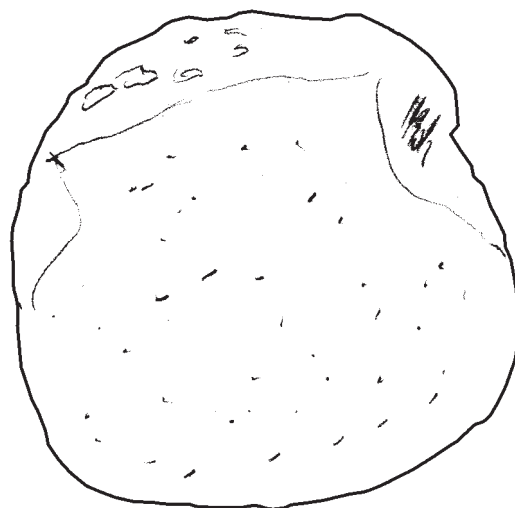
No. 18 C-0463 [002]



No. 19 P0737A

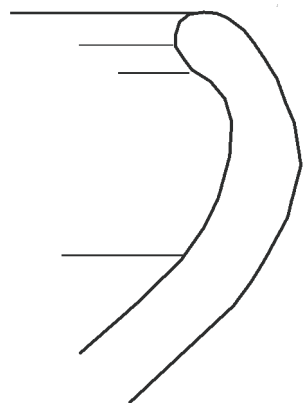


No. 20 P0748A

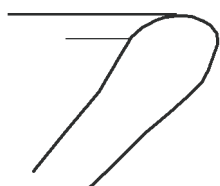


No. 21 F0902A

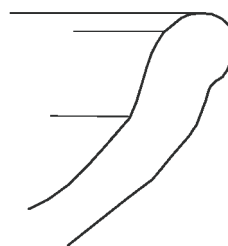




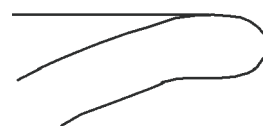
No. 1 C-0488 [008]



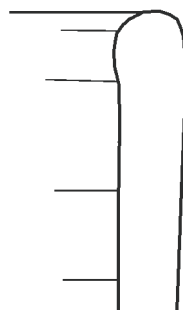
No. 2 C-0488 [006]



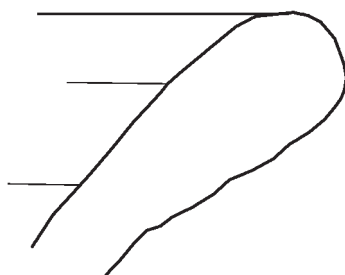
No. 3 C-0670 [001]



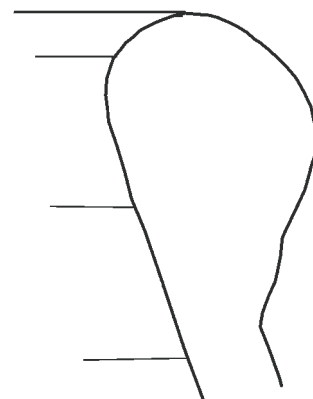
No. 4 C-0670 [002]



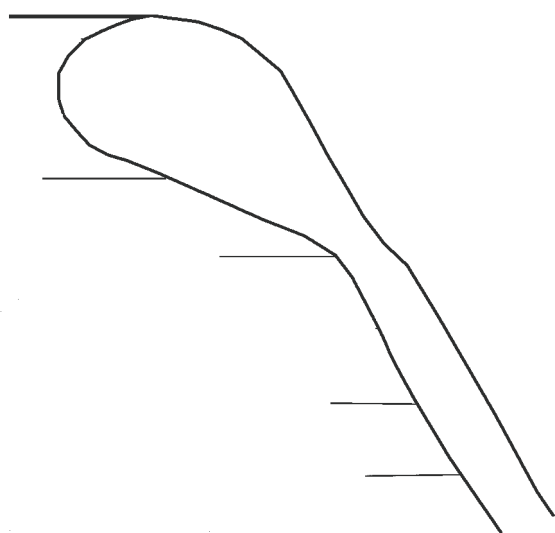
No. 5 C-0488 [004]



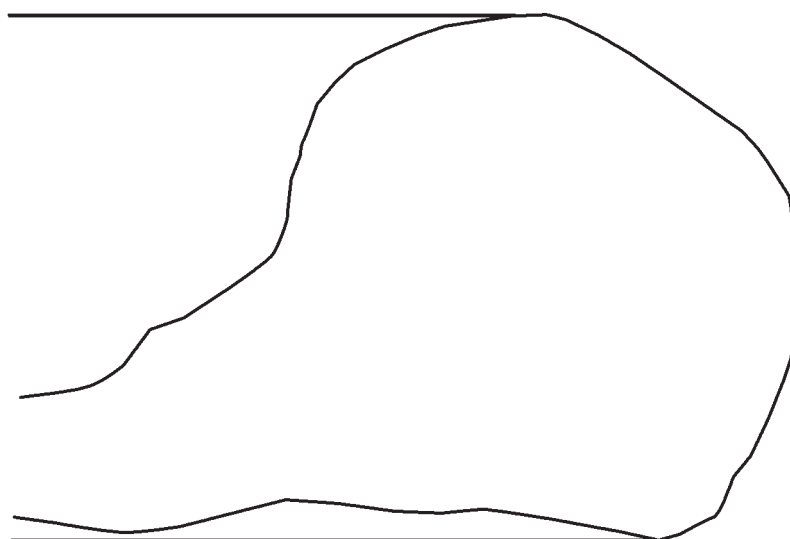
No. 8 C-0488 [002]



No. 9 C-0488 [003]



No. 10 C-0488 [001]

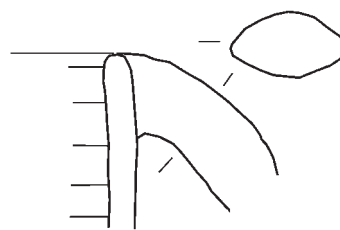


No. 12 C-0439 [001]

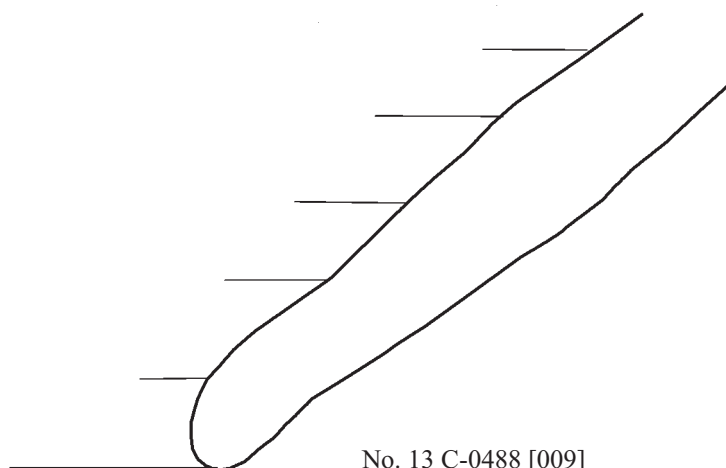
0 1cm

AREA I, L0250 = L0175 = L0280

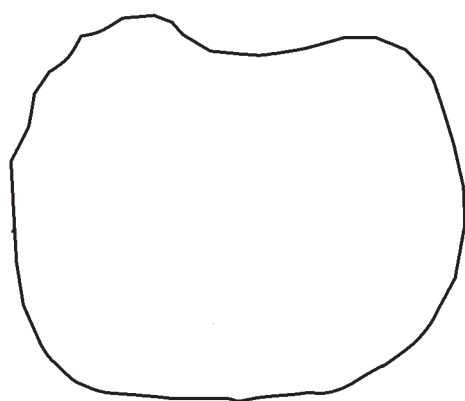
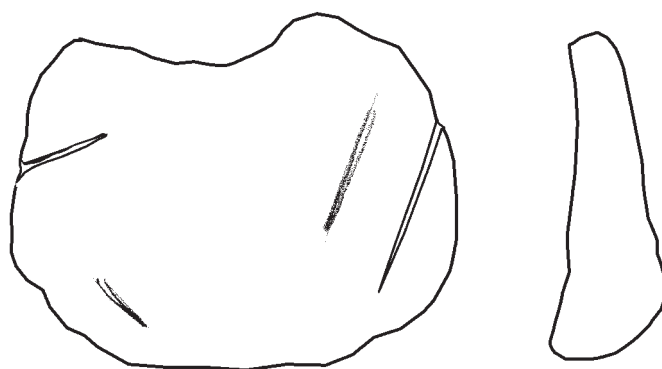
Fig. 29:1



No. 14 C0439 [002]



No. 13 C-0488 [009]



No. 19 F0584A

0 1cm

AREA I, L0250 = L0175 = L0280

Fig. 29:2

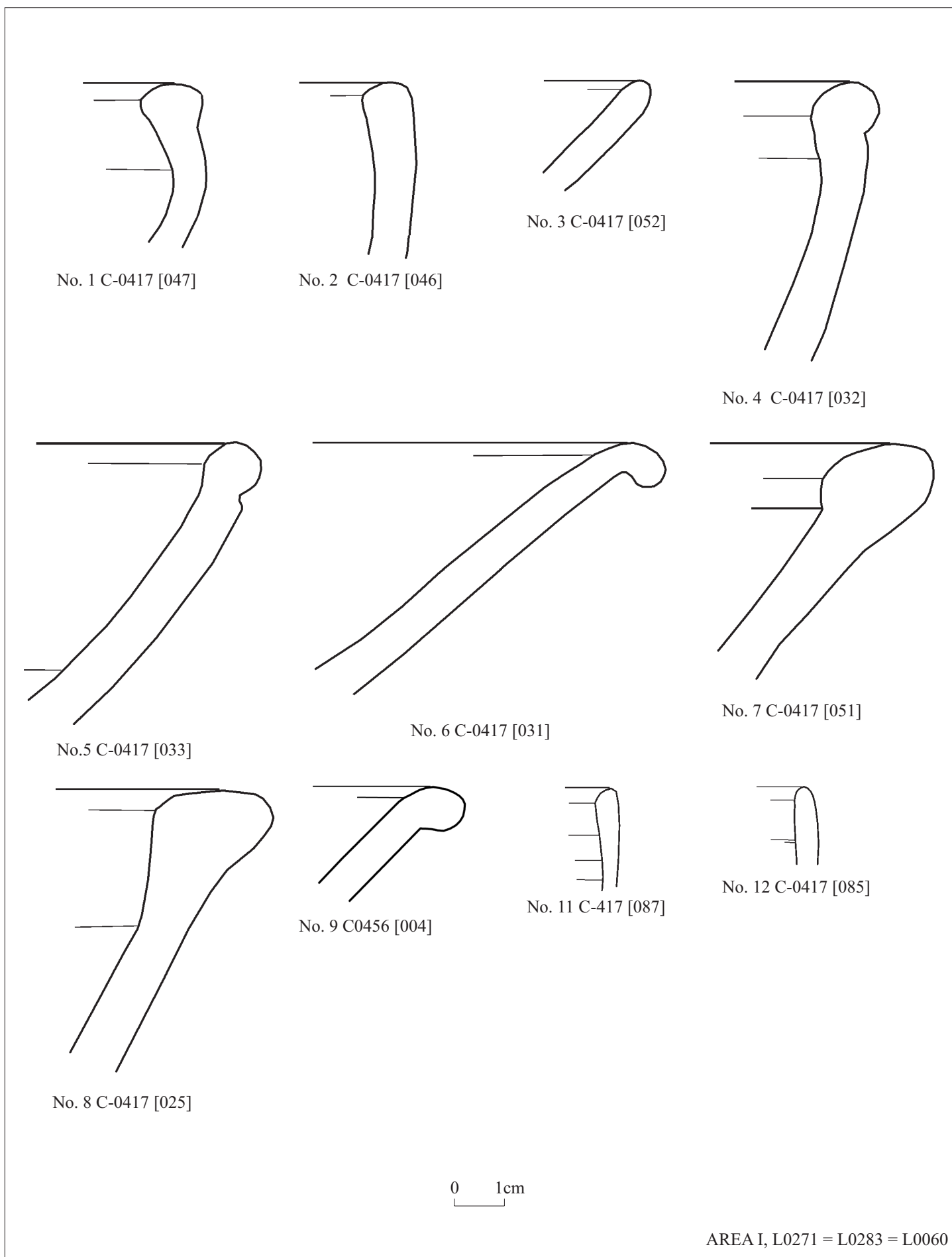
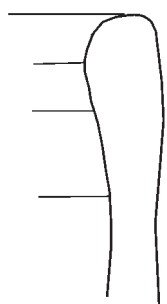
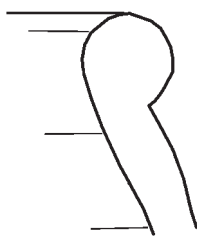


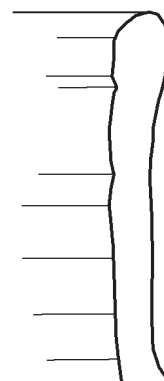
Fig. 30:1



No. 13 C-0417 [015]

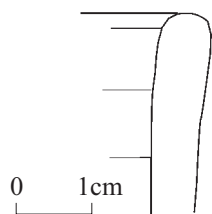


No. 14 C-0417 [029]



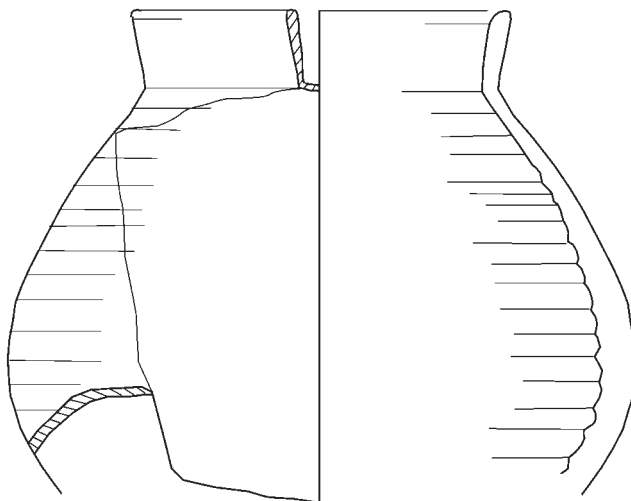
No. 15 C-0417 [008]

0 1cm

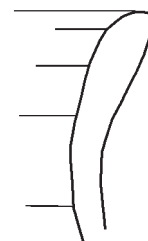


0 1cm

No. 16 C-0417 [012]

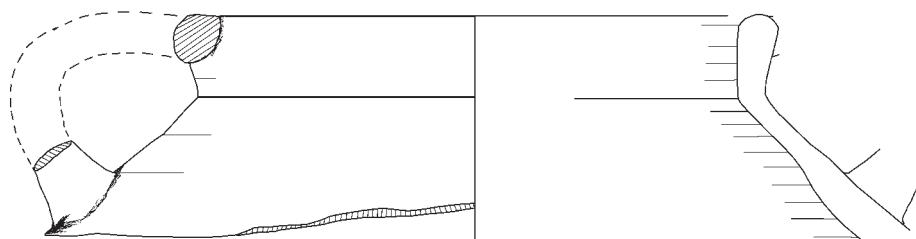


No. 17 P0759A



0 1cm

No. 18 C-0417 [028]

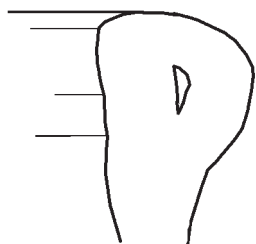


No. 19 P1304A

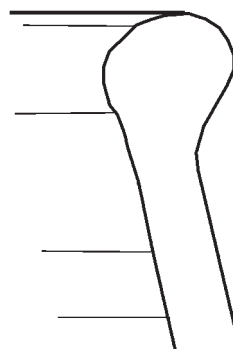
0 2cm

AREA I, L0271 = L0283 = L0060

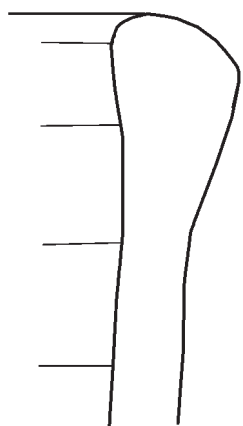
Fig. 30:2



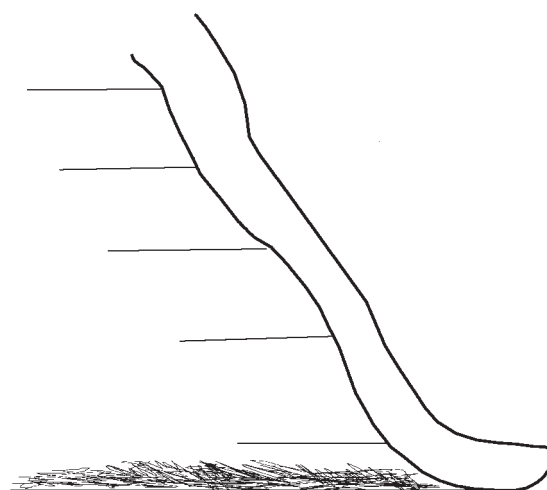
No. 22 C-0417 [028]



No. 23 C-0417 [026]

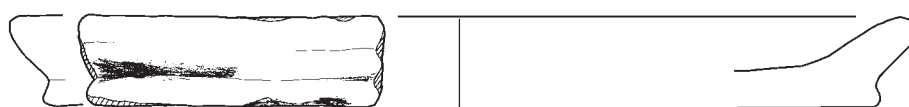


No. 24 C-0417 [024]

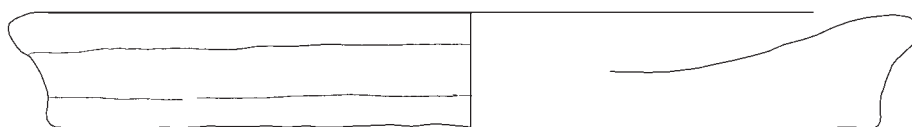


No. 25 C-0417 [062]

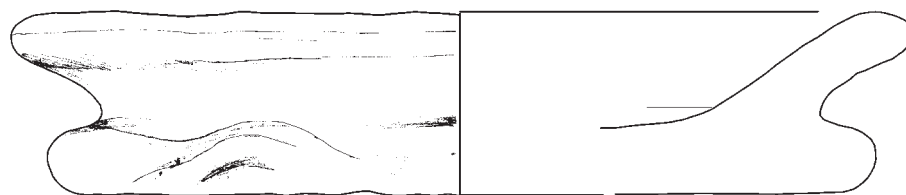
0 1cm



No. 26 P1301A



No. 27 P1300A

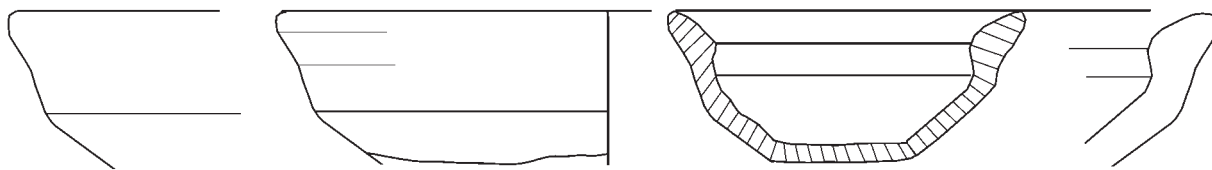


No. 28 P1302A

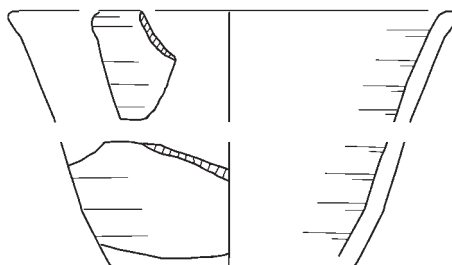
0 2cm

AREA I, L0271 = L0283 = L0060

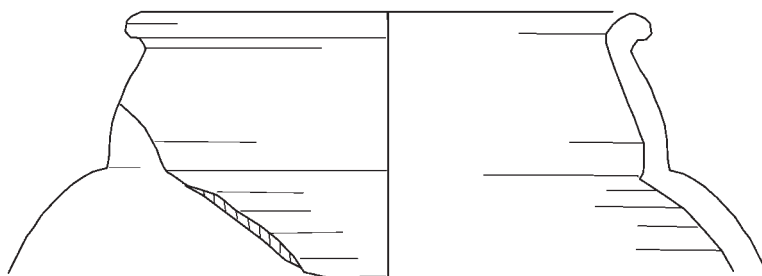
Fig. 30:3



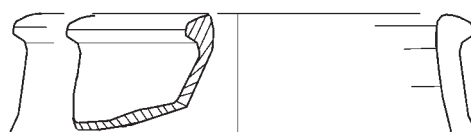
No. 30 P0833A



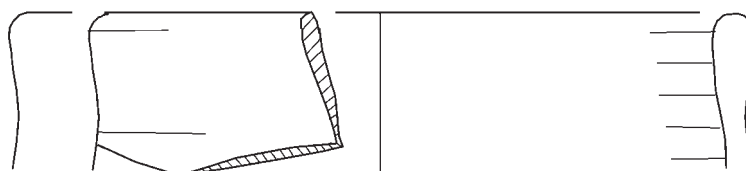
No. 31 P1245A



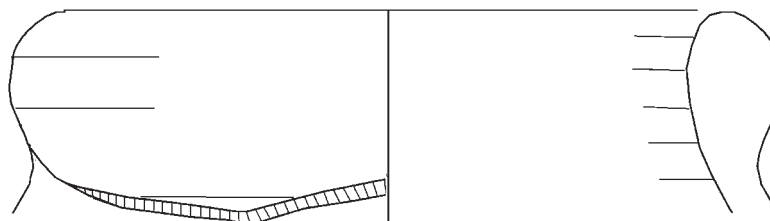
No. 33 P0832A



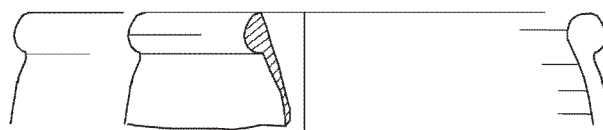
No. 34 P0834A



No. 35 P0825A



No. 36 P1297A

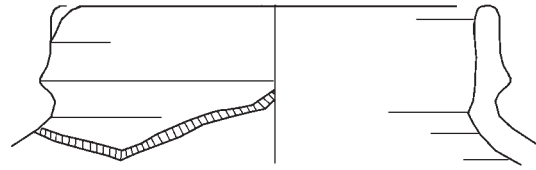


No. 37 P0826A

0 1cm

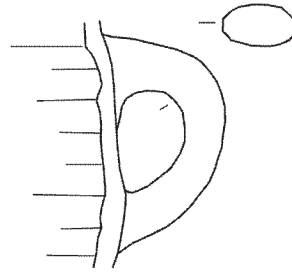
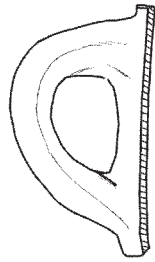
AREA I, L0271 = L0283 = L0060

Fig. 30:4



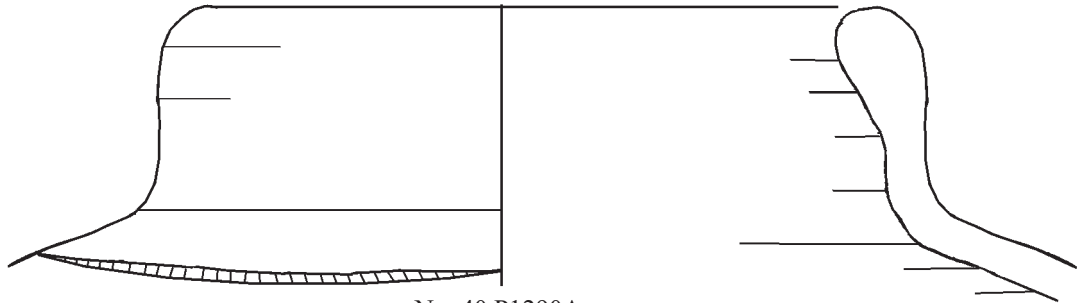
No. 38 P1151A

0 1cm

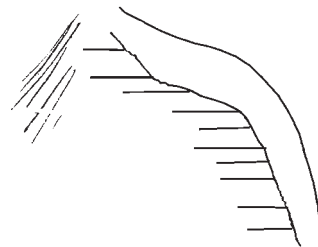
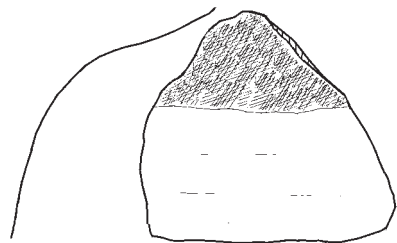


No. 39 P7011A

0 4cm

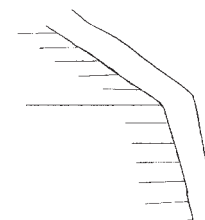
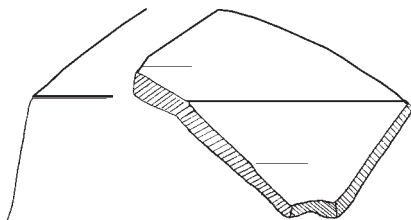


No. 40 P1290A



No. 41 P1285A

0 1cm



No. 42 P2029A

0 2cm

AREA I, L0271 = L0283 = L0060

Fig. 30:5

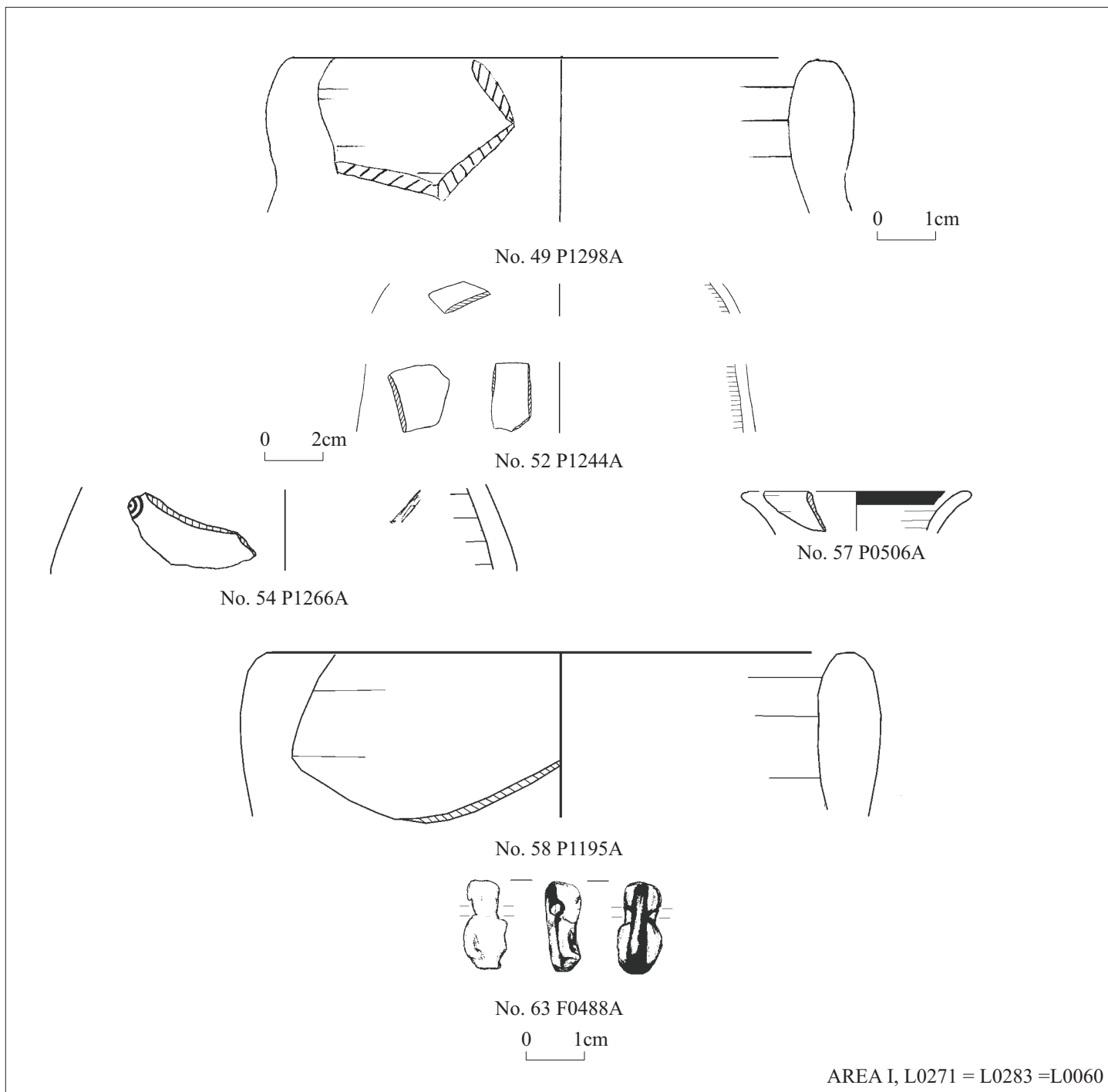
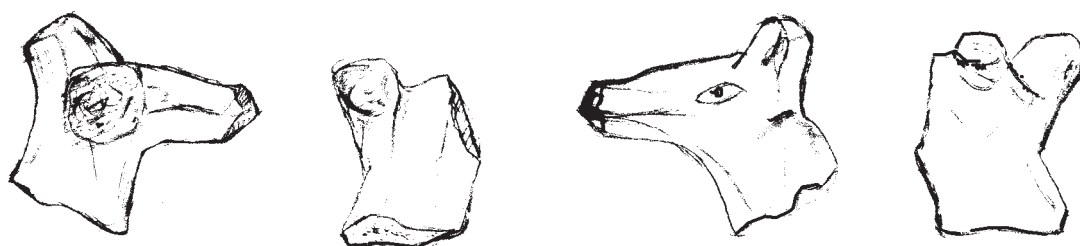


Fig. 30:6

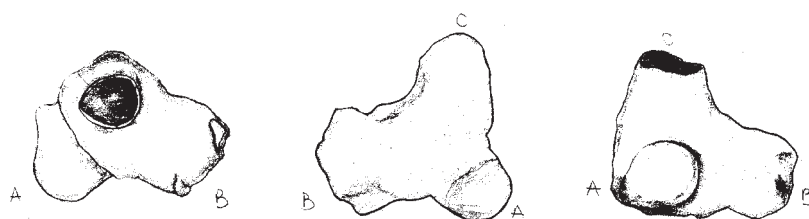


No. 62 F0486

AREA I, L0271 = L0283 = L0060

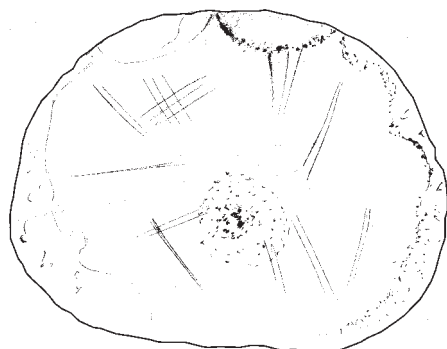
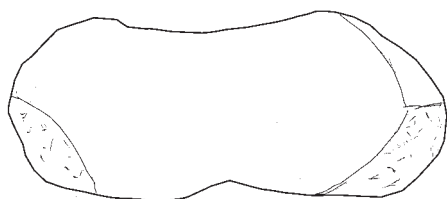
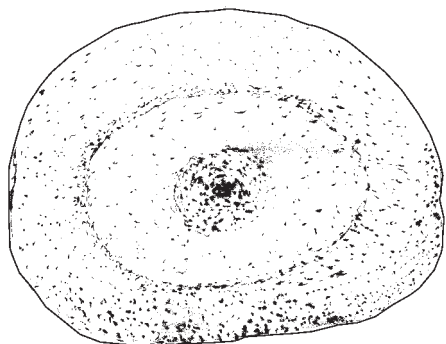


No. 66 F0459



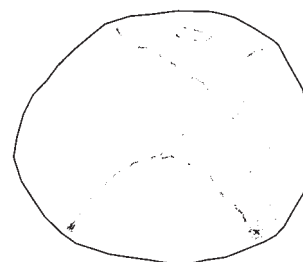
No. 67 F0472A

0 1cm



0 2cm

No. 74 F0503A



0 1cm

No. 75 F0905A

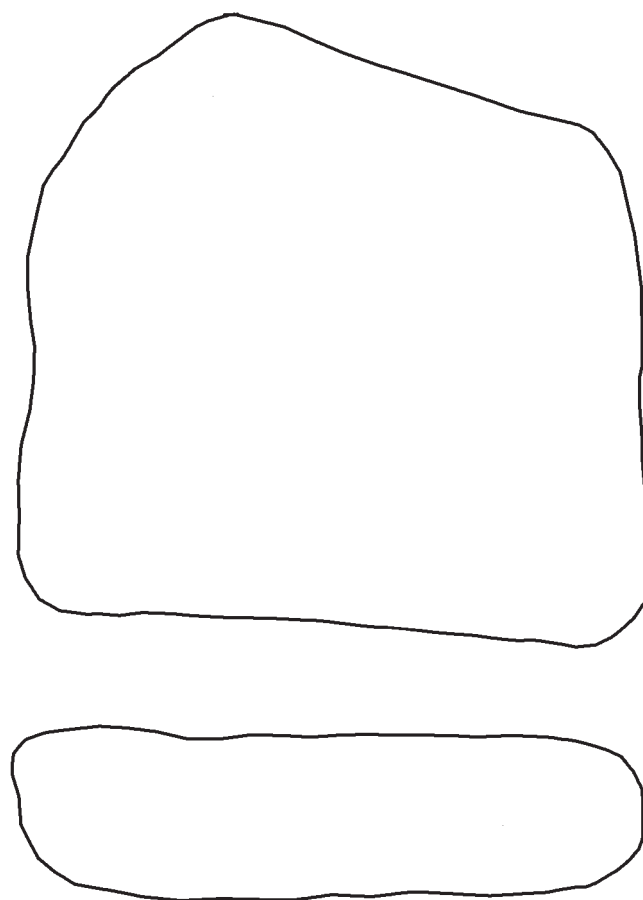


0 2cm

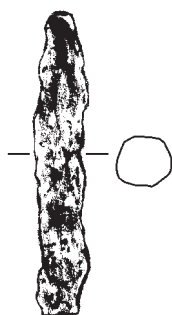
No. 77 F0328

AREA I, L0271 = L0283 = L0060

Fig. 30:7



No. 78 F0579A

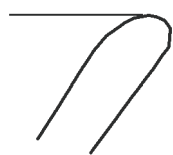


No. 79 F0326A

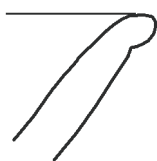


AREA I, L0271 = L0283 = L0060

Fig. 30:8



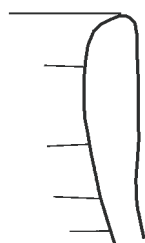
No. 1 C-0506 [003]



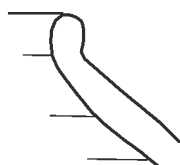
No. 2 C-0506 [011]



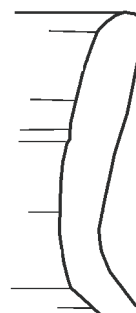
No. 3 C-0506 [004]



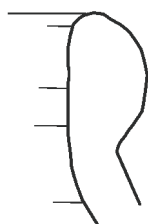
No. 4 C-0506 [009]



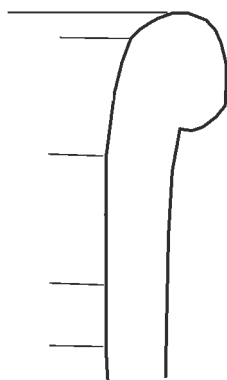
No. 5 C-0506 [008]



No. 6 C-0506 [005]



No. 7 C-0506 [013]



No. 10 C-0506 [001]



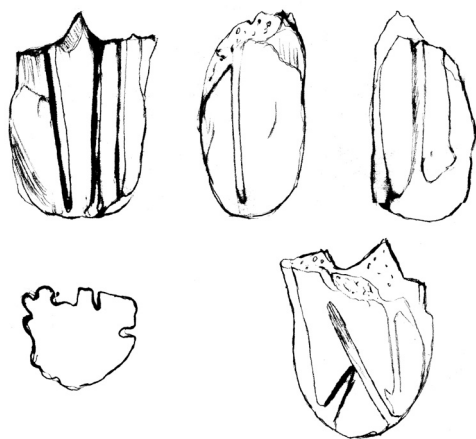
No. 11 C-0506 [002]

0 1cm

Fig. 31:1



No. 15 F0505A



No. 16 F0540A

0 2cm

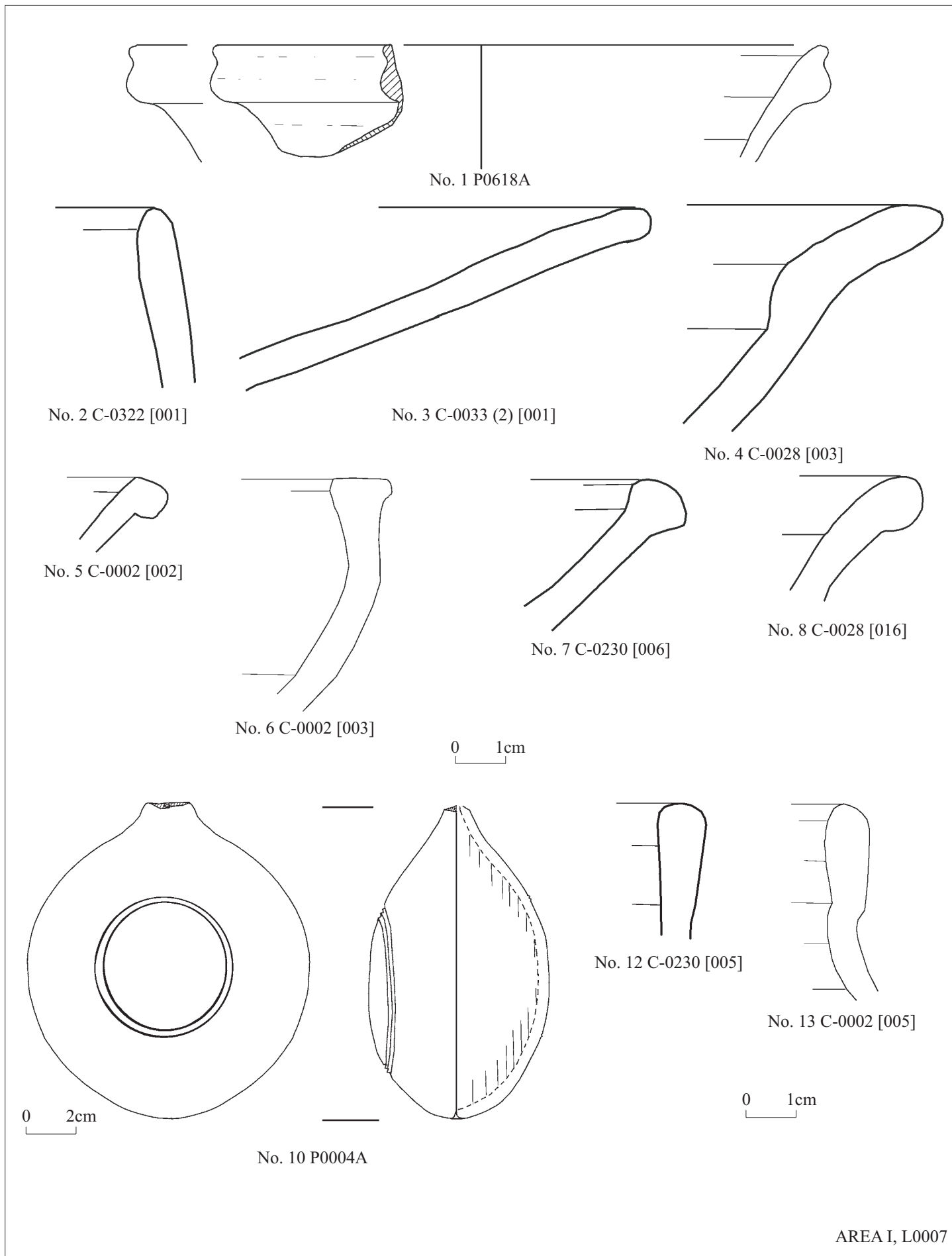


Fig. 32:1

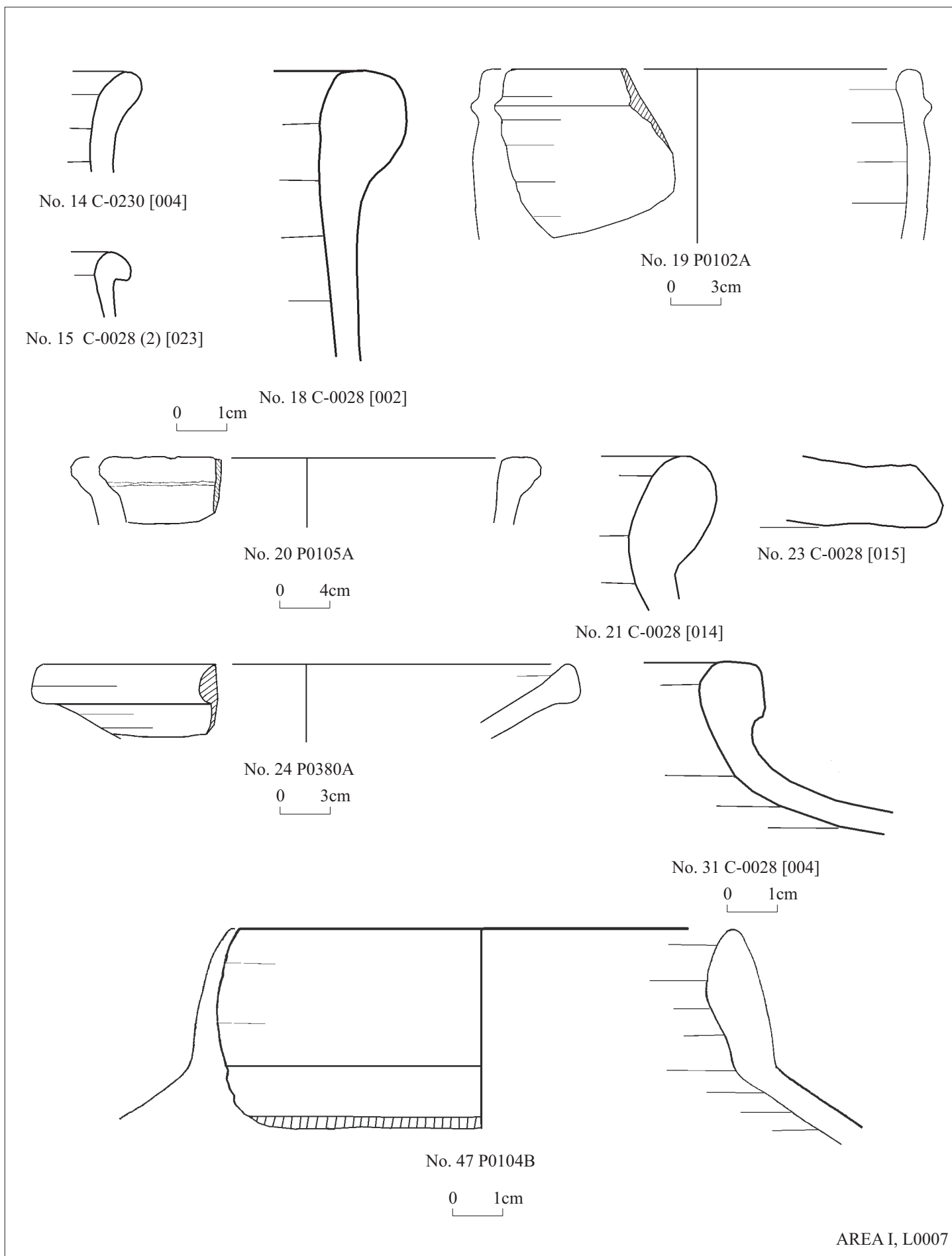


Fig. 32:2



No. 49 F0014A

AREA I, L0007

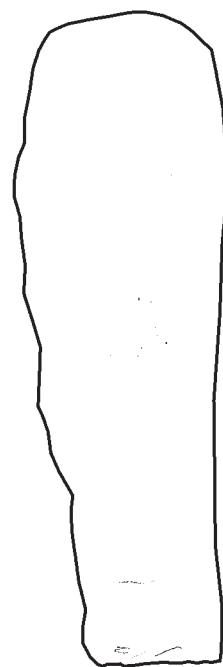
Plate 12



No. 50 F1003A



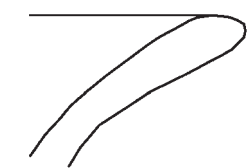
No. 51 F0426A



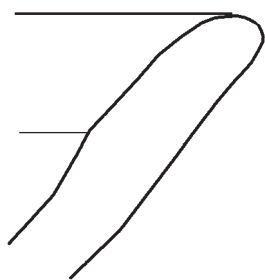
0 1cm

AREA I, L0007

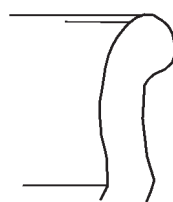
Fig. 32:3



No. 1 C-0637 [014]



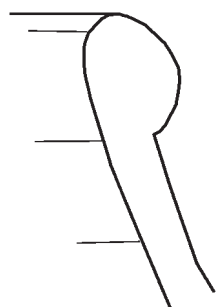
No. 2 C-0637 [012]



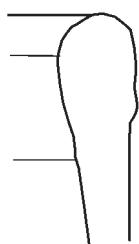
No. 3 C-0637 [011]



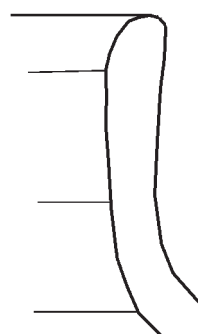
No. 4 C-0637 [013]



No. 5 C-0637 [004]



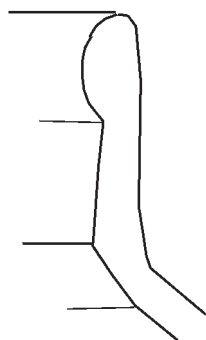
No. 6 C-0637 [002]



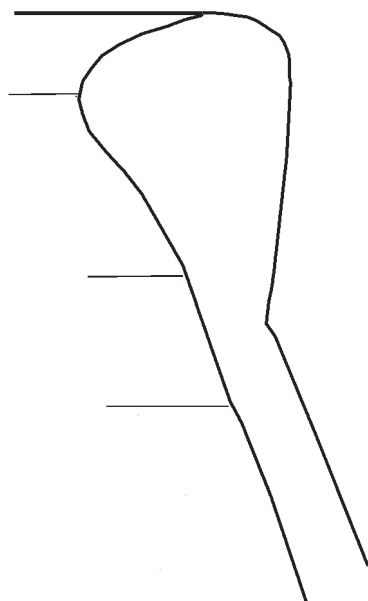
No. 7 C-0637 [007]



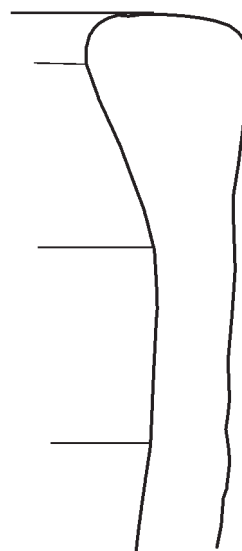
No. 8 C-0637 [010]



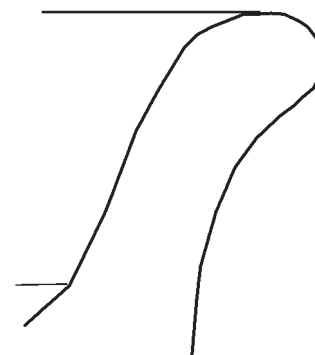
No. 9 C-0637 [001]



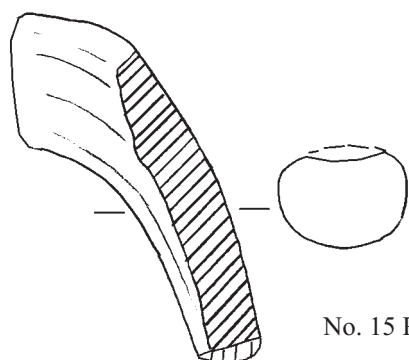
No. 11 C-0637 [016]



No. 12 C-0637 [015]



No. 13 C-0637 [017]



No. 15 P2031A



No. 22F0874A



No. 20 C-0637 [003]

AREA I, L0067

Fig. 33

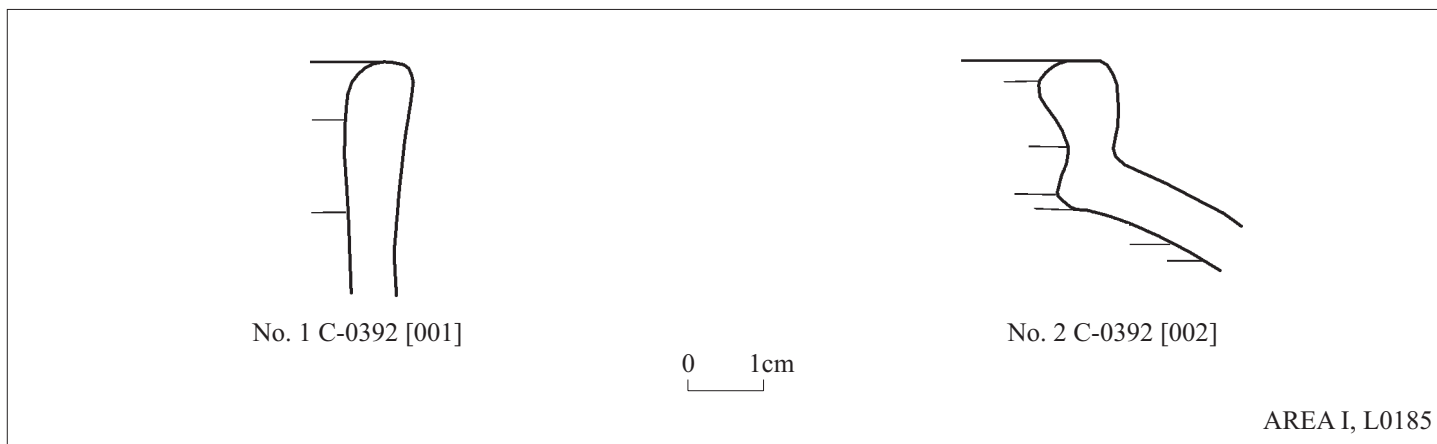


Fig. 34

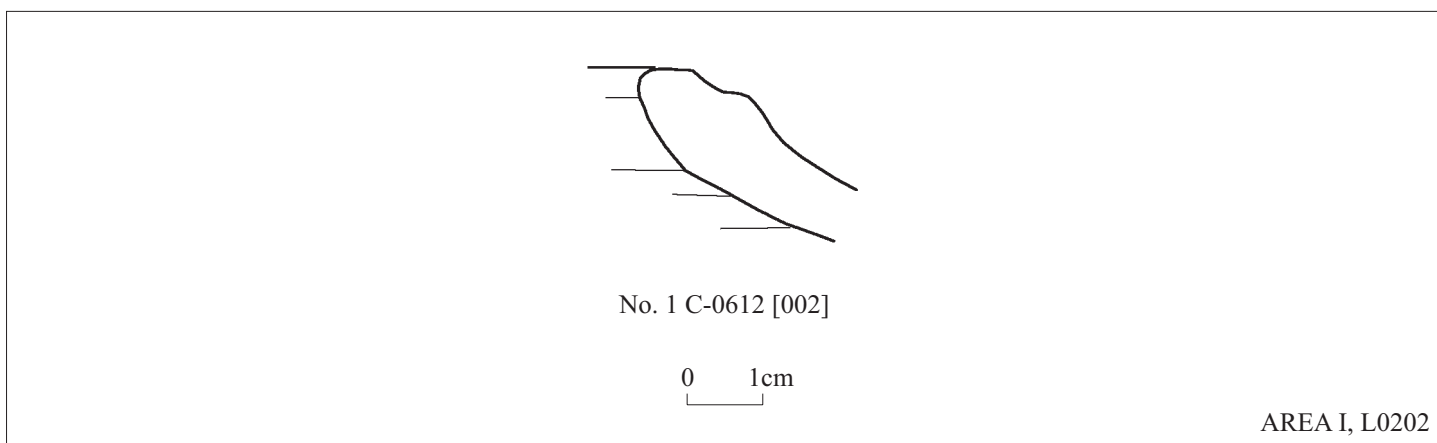


Fig. 35

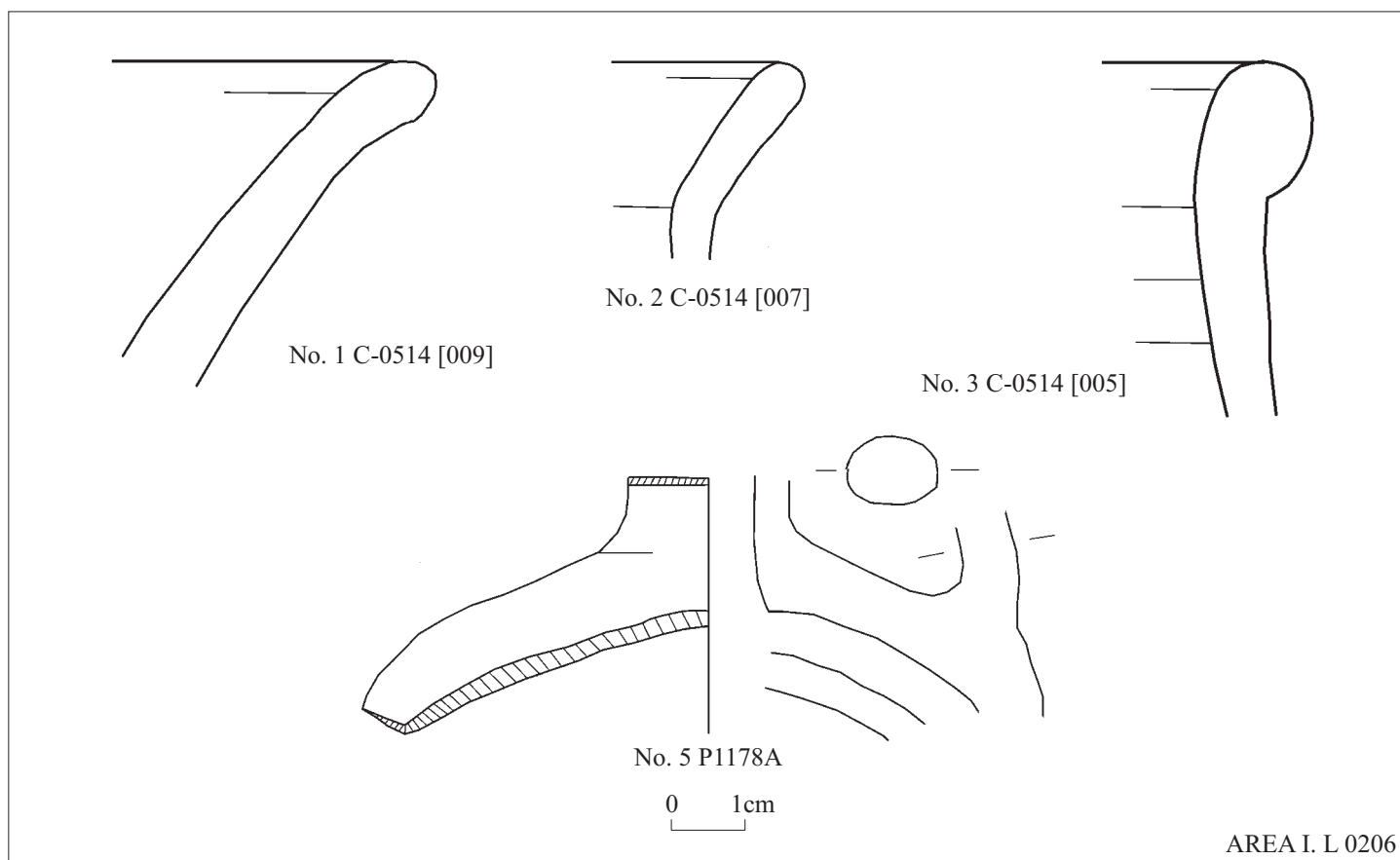
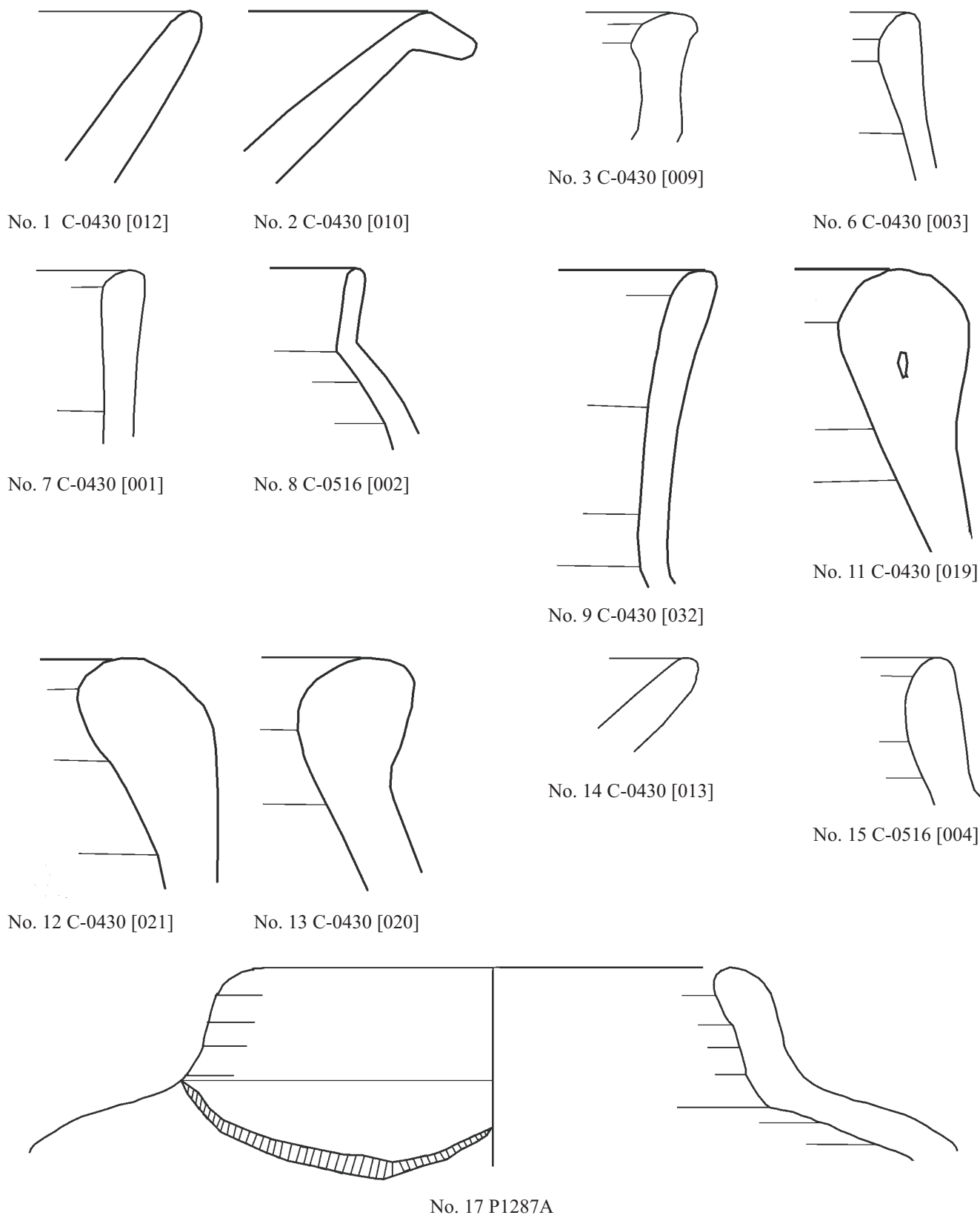
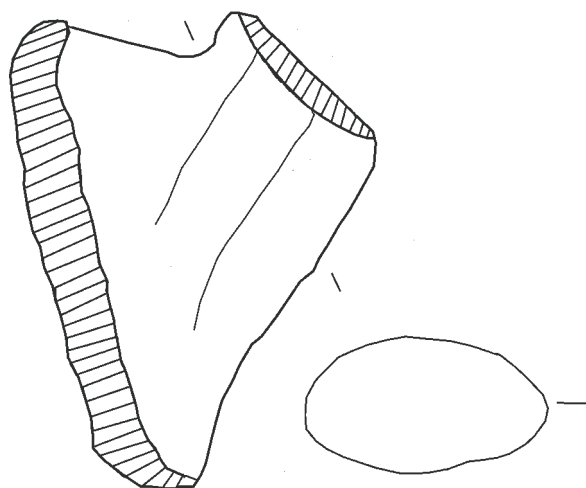


Fig. 36

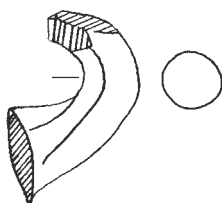


AREA I, L0244

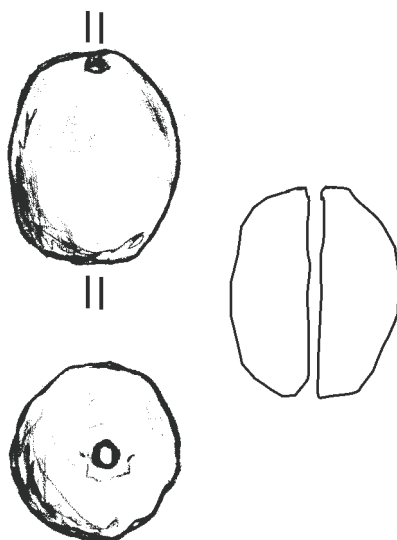
Fig. 37:1



No. 18 P1286A



No. 20 P0870A



No. 21 F0498

0 1cm

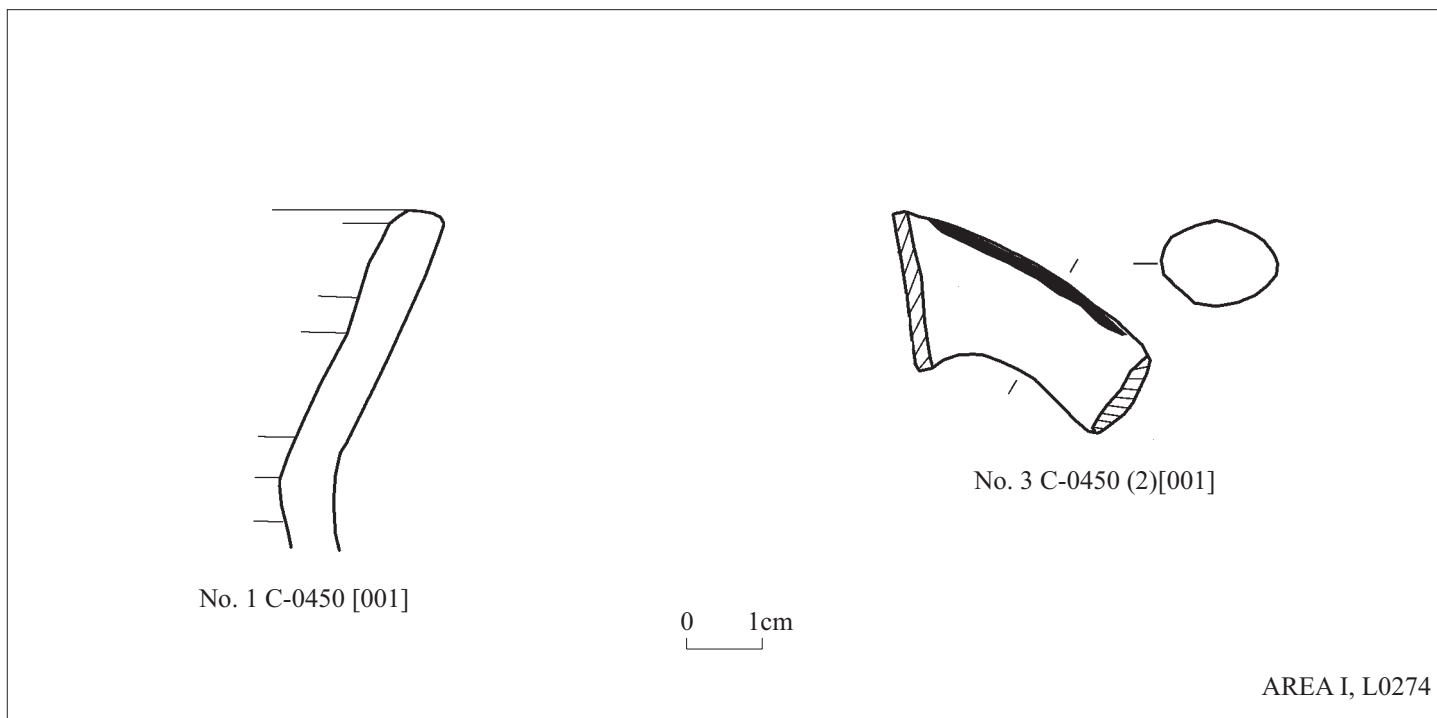


Fig. 38

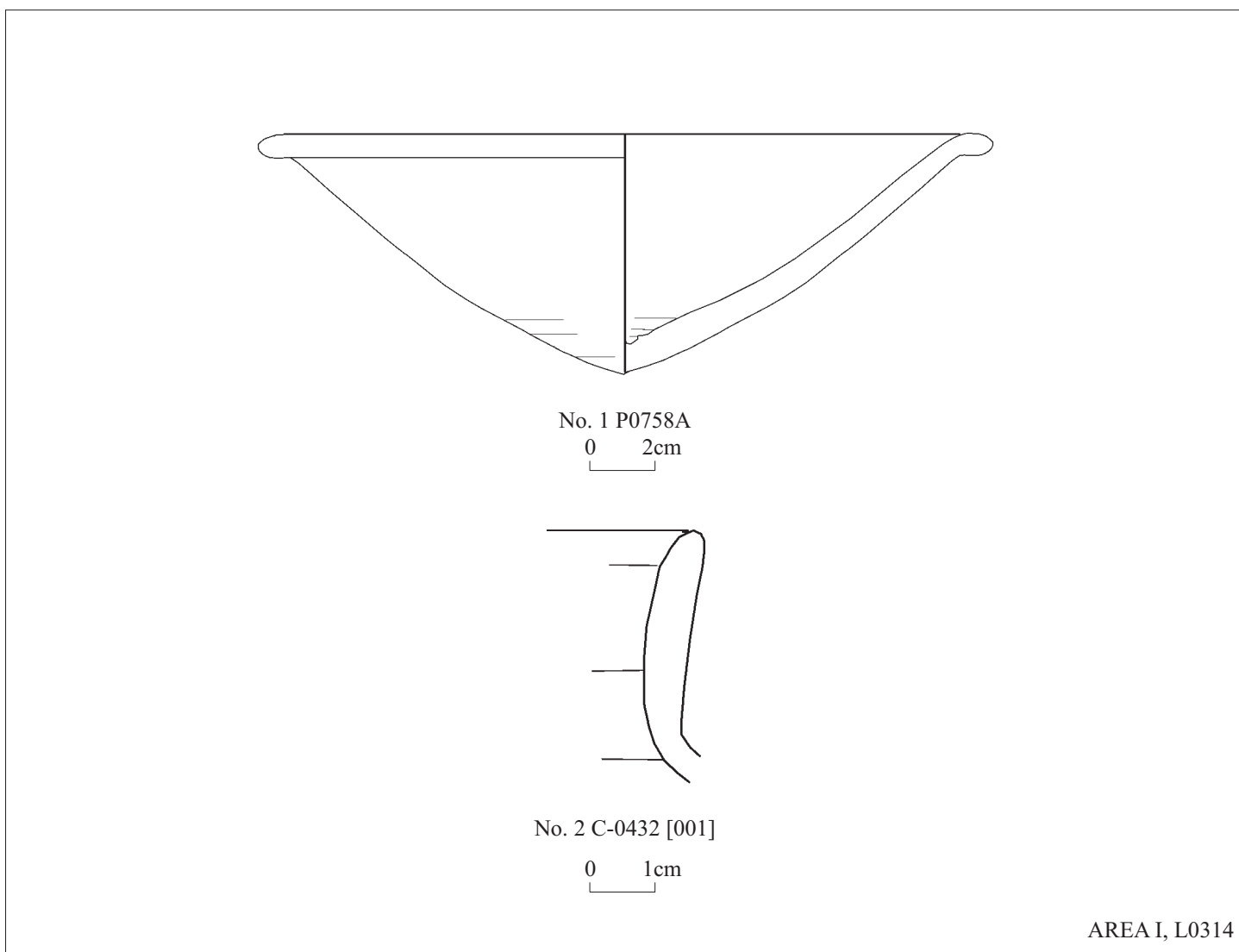
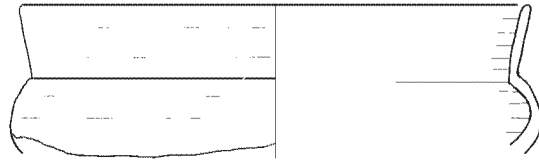
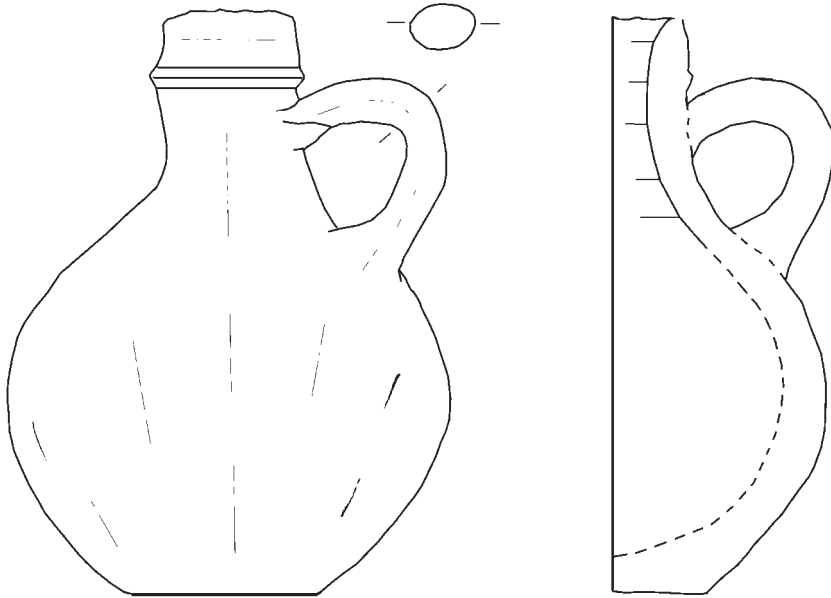


Fig. 39

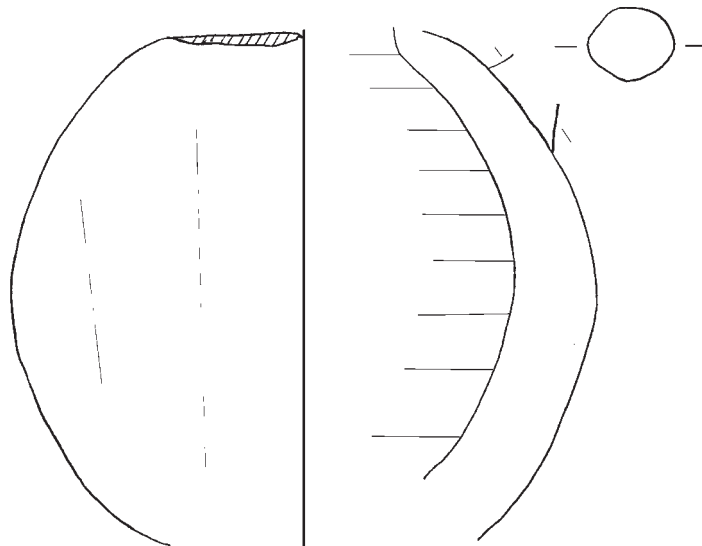


No. 1 P1062A

0 2cm

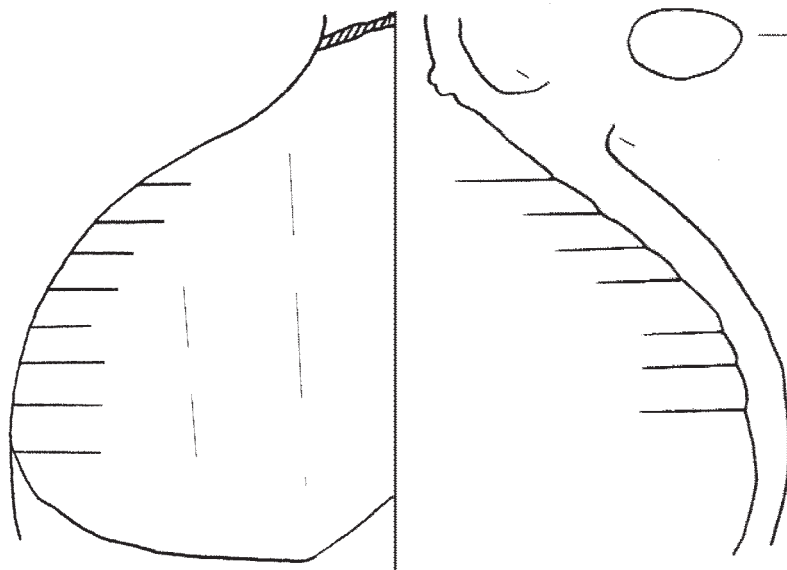


No. 2 P0624

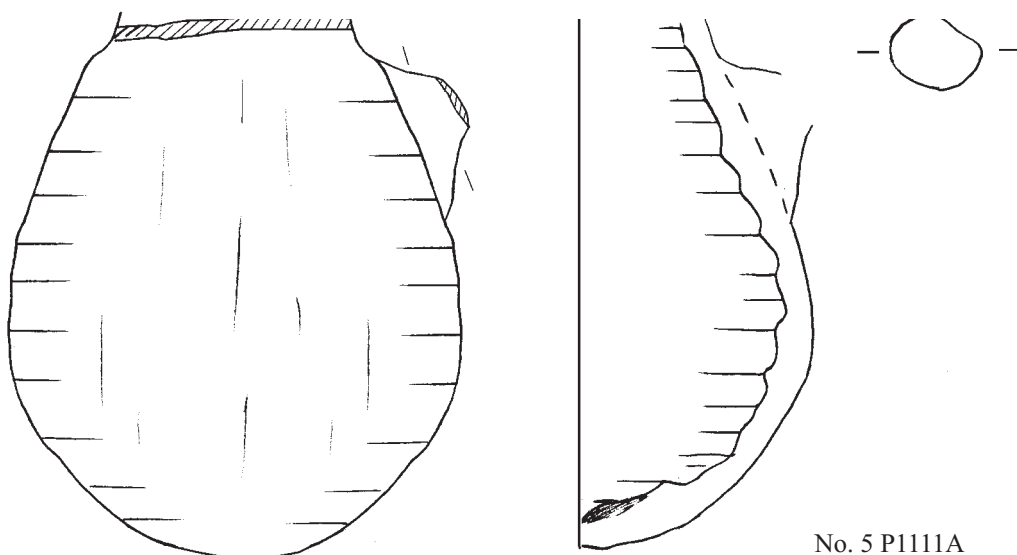


No. 3 P1237A

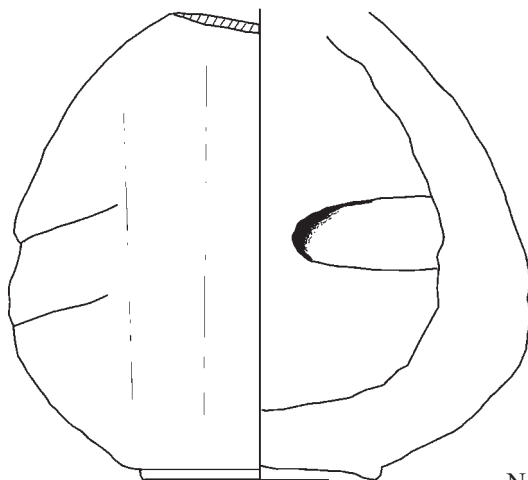
0 1cm



No. 4 P1155A



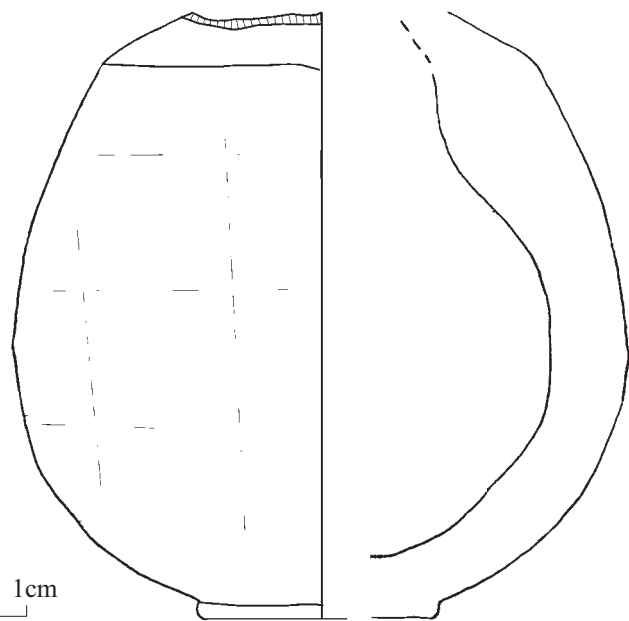
No. 5 P1111A



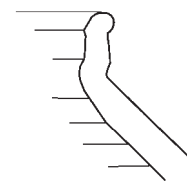
No. 6 P0077A

0 1cm

Fig. 40:2



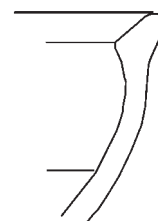
No. 7 P1057A



No. 9 C-0014 (2) [001]



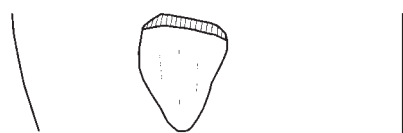
No. 11 C-0380 [027]



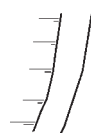
No. 13 C-0084 [005]

0 1cm

0 2cm

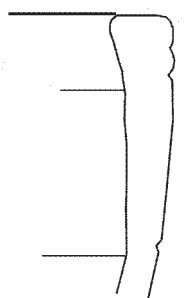


No. 10 P0876A



No. 14 C-0020 [003]

0 1cm



No. 18 C-0135 [005]

0 2cm



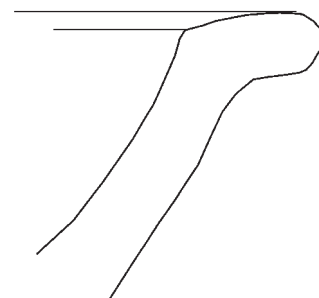
No. 19 C-0380 [088]

0 1cm



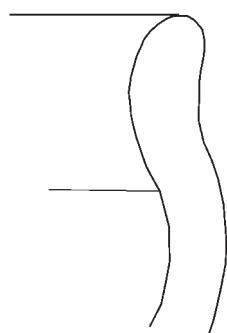
No. 22 C-0521 [167]

0 2cm



No. 23 C-0521 [052]

0 1cm



No. 24 C-0521 [056]

0 1cm

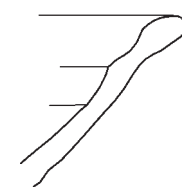


No. 25 C-0521 [054]



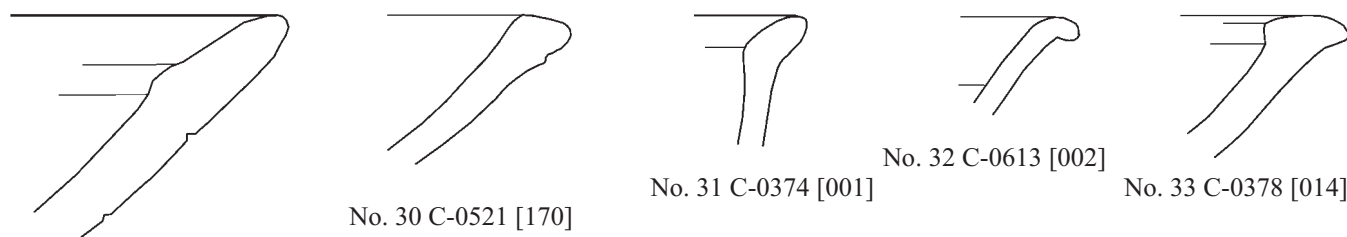
No. 26 C-0378 [009]

0 2cm

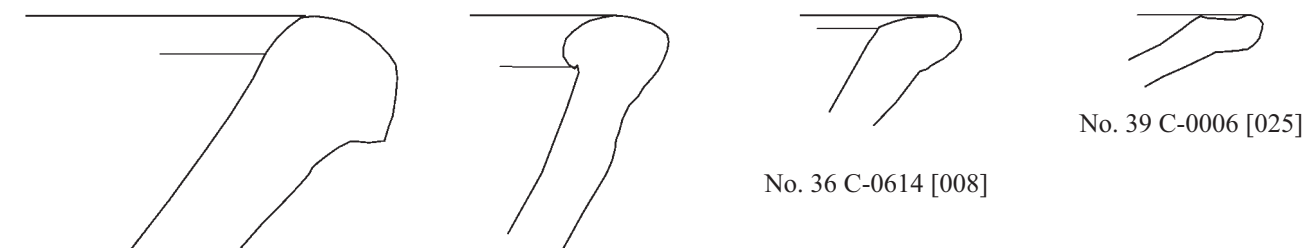


No. 28 C-0020 [002]

Fig. 40:3

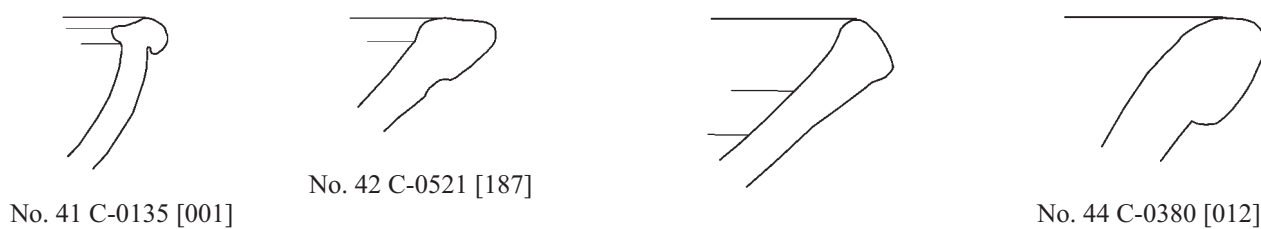


0 2cm



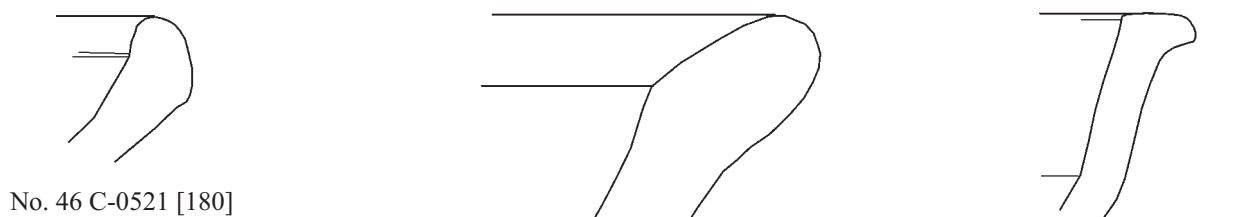
0 2cm

0 1cm



0 2cm

0 1cm

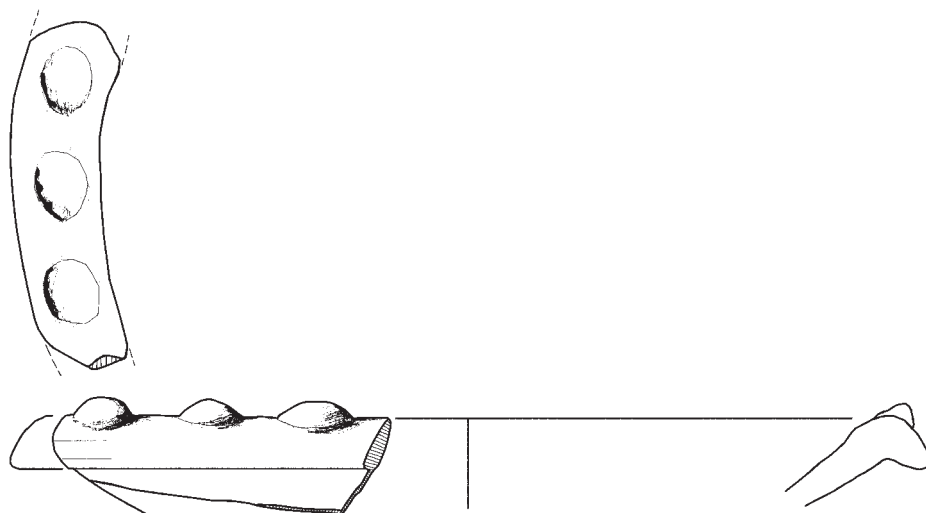


0 2cm

0 1cm

0 2cm

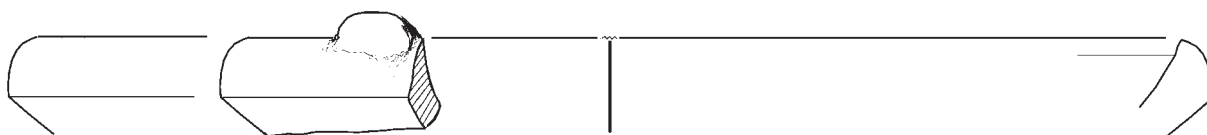
Fig. 40:4



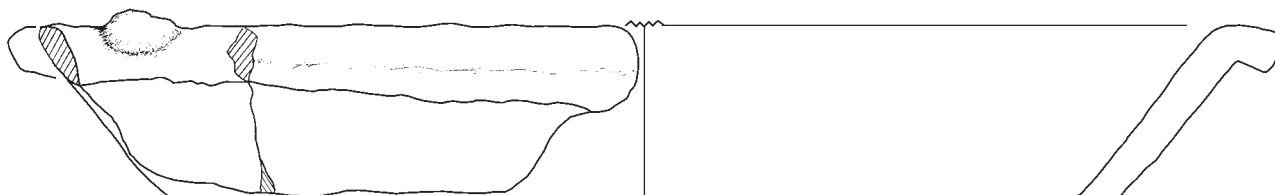
No. 49 P7060A



No. 50 C-0521 [019]

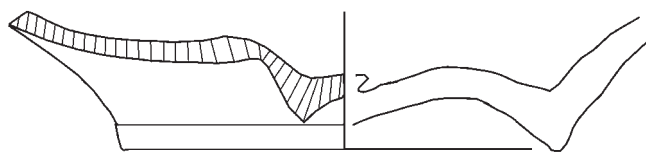


No. 51 P0841A



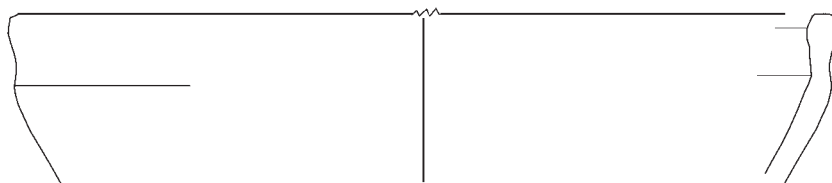
No. 52 P1012A

0 2cm



No. 54 P0634A

0 1cm



No. 58 C-0380 [046]

0 2cm

Fig. 40:5

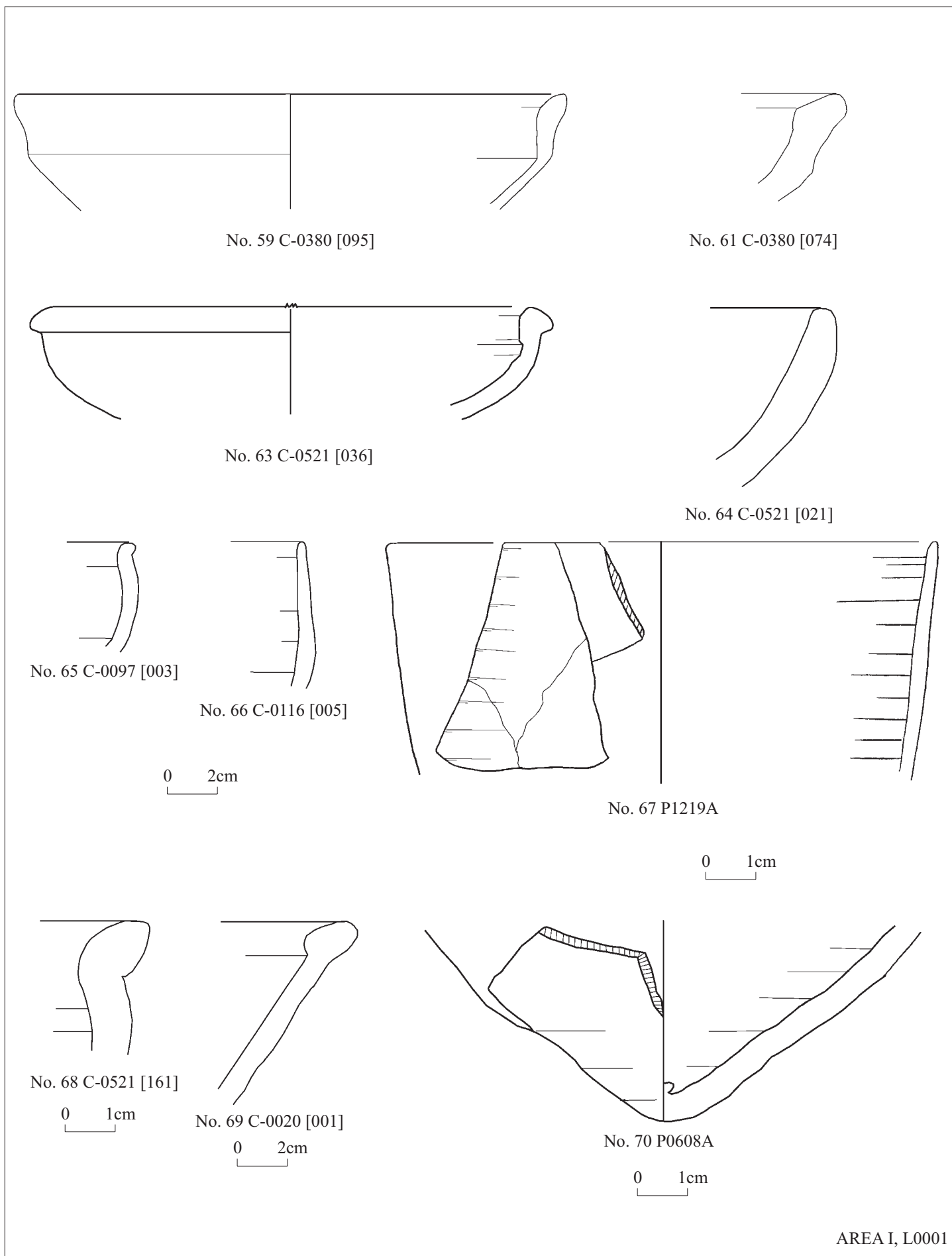


Fig. 40:6

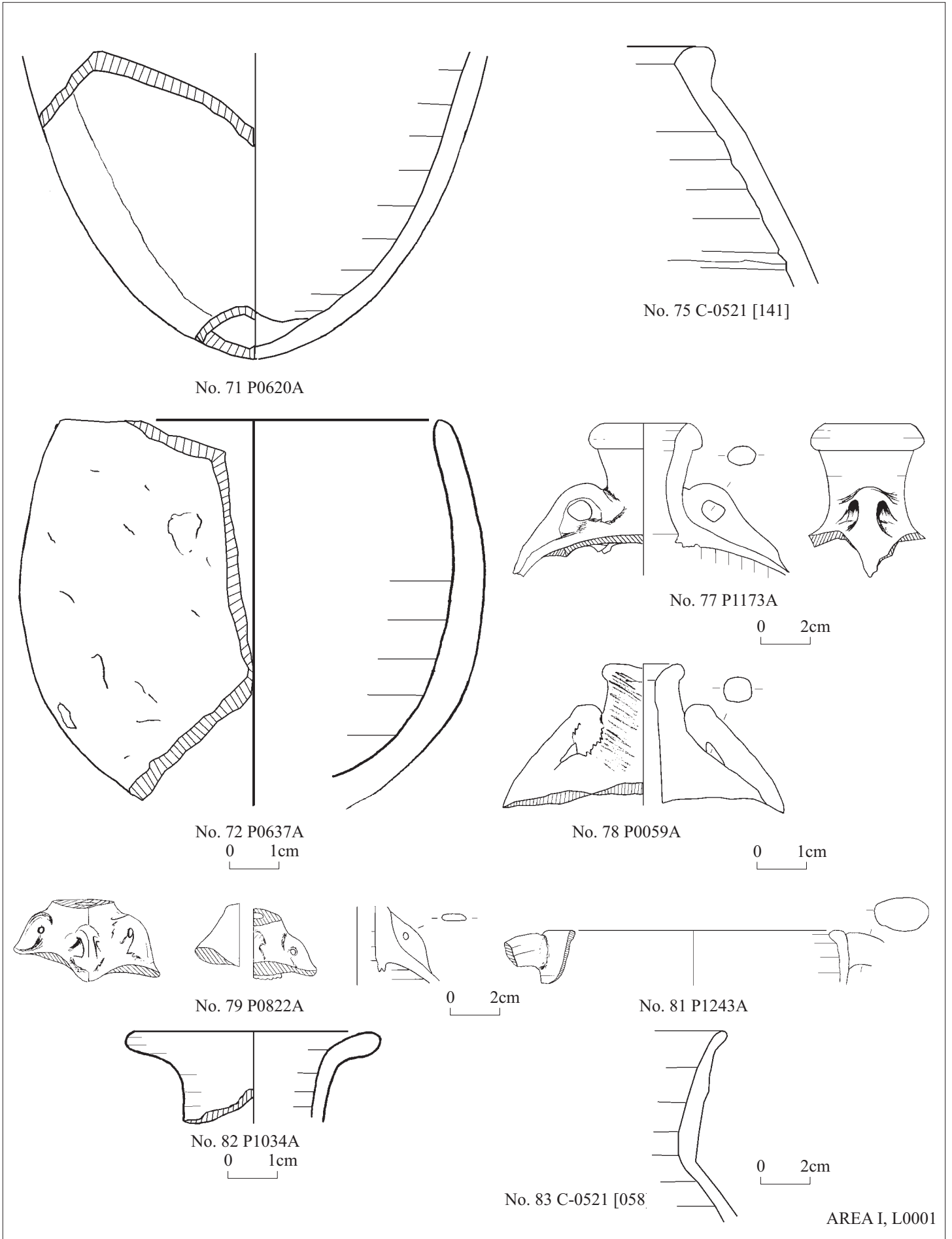
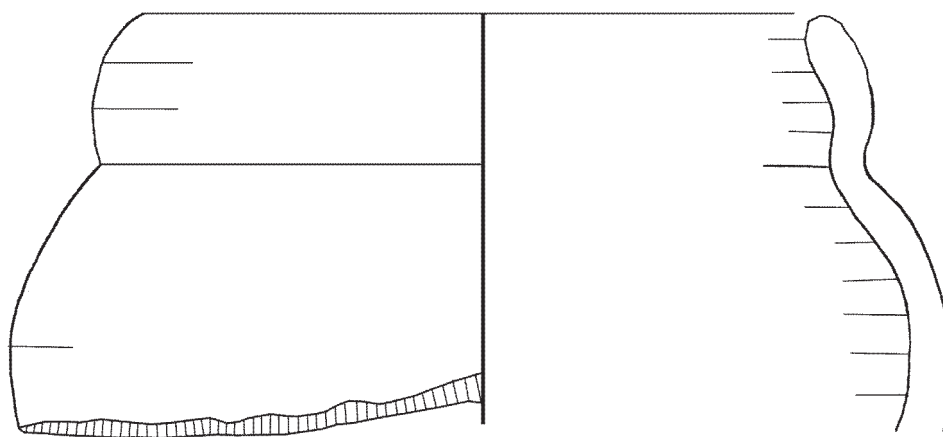
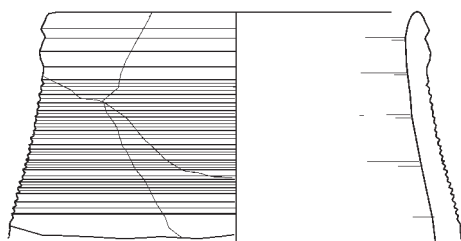


Fig. 40:7

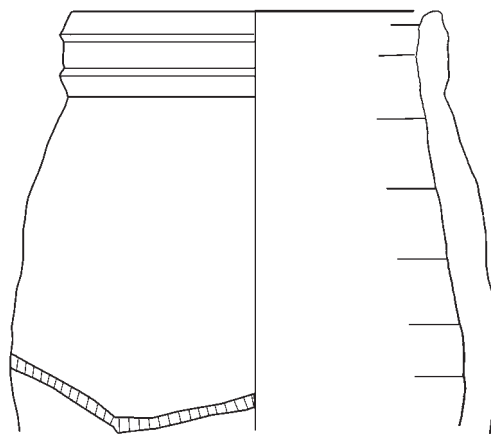


No. 84 P0164A

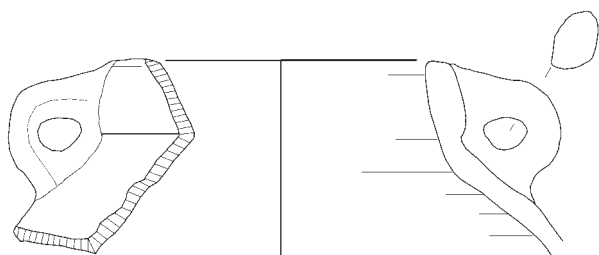
0 1cm



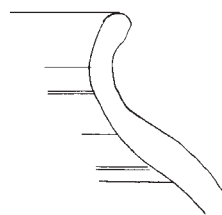
No. 85 P0223A



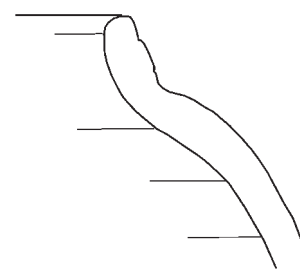
No. 86 P0614A



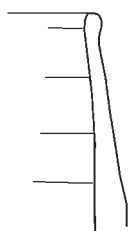
No. 87 P0615A



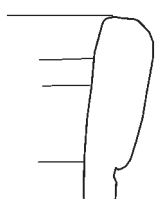
No. 91 C-0376 [004]



No. 92 C-0378 [002]



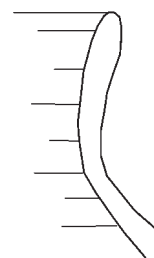
No. 93 C-0380 [014]



No. 94 C-0040 [001]



No. 95 C-0015 [006]

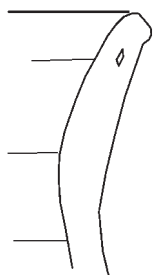


No. 96 C-0396 [002]

0 2cm

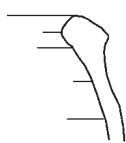
AREA I, L0001

Fig. 40:8



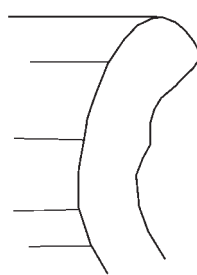
No. 97 C-0521 [070]

0 1cm

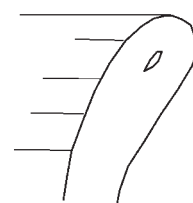


No. 98 C-0378 [001]

0 2cm

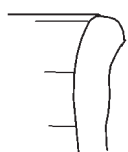


No. 99 C-0521 [045]

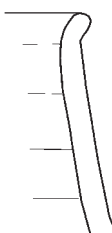


No. 100 C-0521 [074]

0 1cm

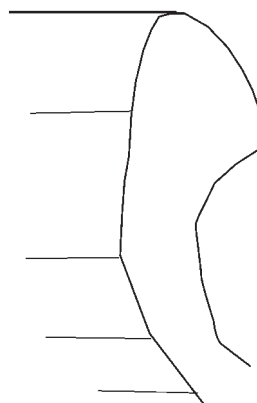


No. 101 C-0613 [006]



No. 102 C-0380 [033]

0 2cm



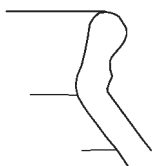
No. 103 C-0521 [013]

0 1cm



No. 105 C-0521 [162]

0 2cm



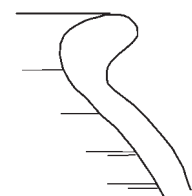
No. 106 C-0003 [001]



No. 108 C-0116 [011]

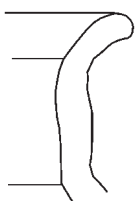


No. 109 C-0003 [011]

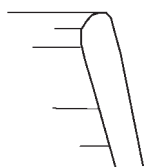


No. 110 C-0521 [174]

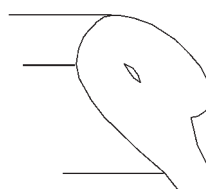
0 2cm



No. 111 C-0521 [178]

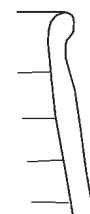


No. 112 C-0396 [008]



No. 113 C-0380 [076]

0 1cm

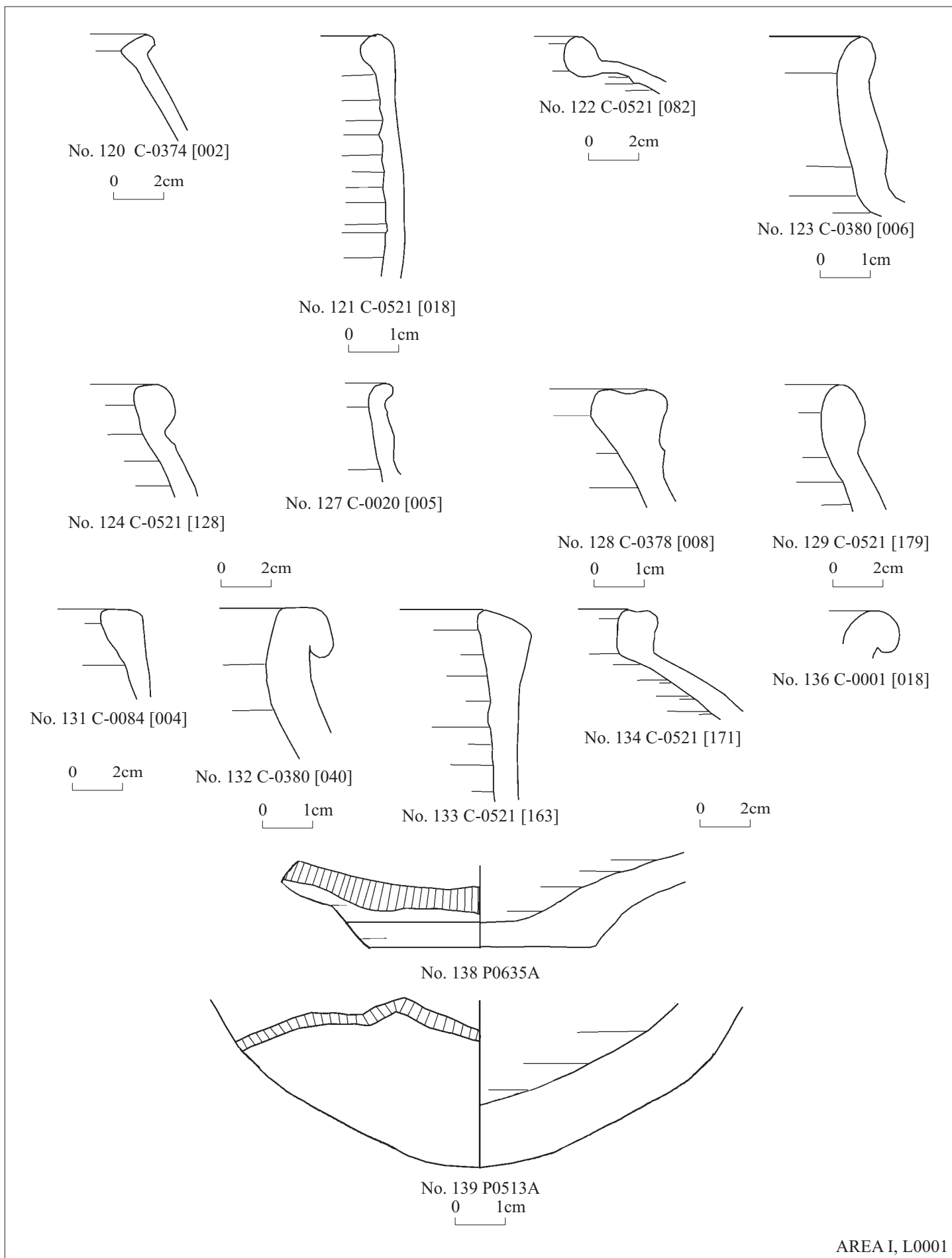


No. 118 C-0521 [008]

0 2cm

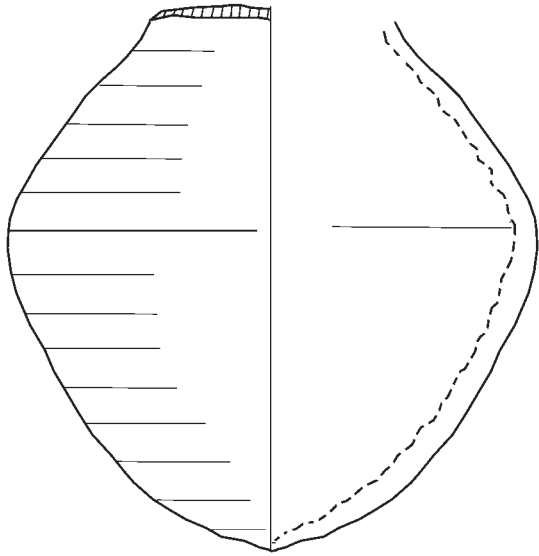
0 2cm

AREA I, L0001

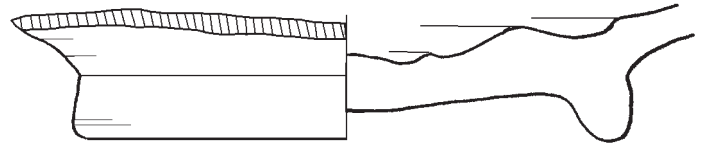


AREA I, L0001

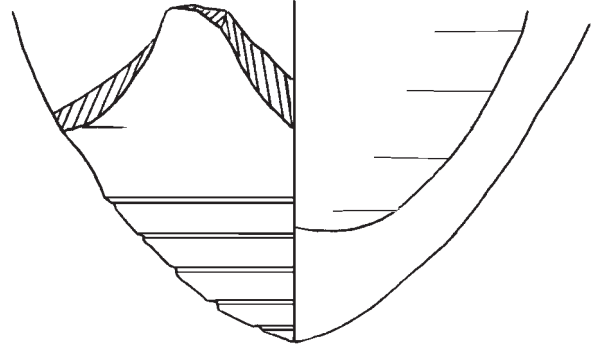
Fig. 40:10



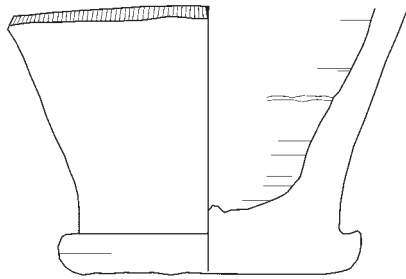
No. 140 P0214A



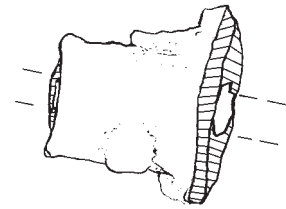
No. 141 P0009A



No. 142 P1216A



No.142bis C-0521 [600]

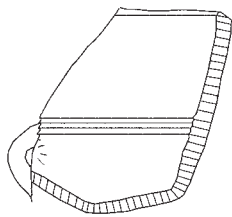


No. 144 P0221A

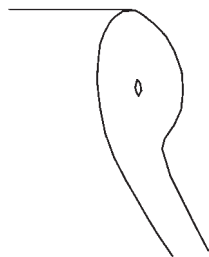


0 2cm

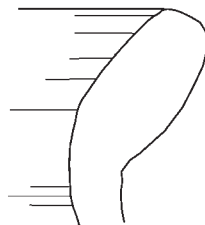
0 1cm



No. 143 P0161A

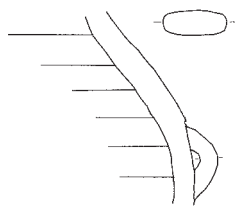


No. 145 C-0380 [044]



No. 146 C-0521 [005]

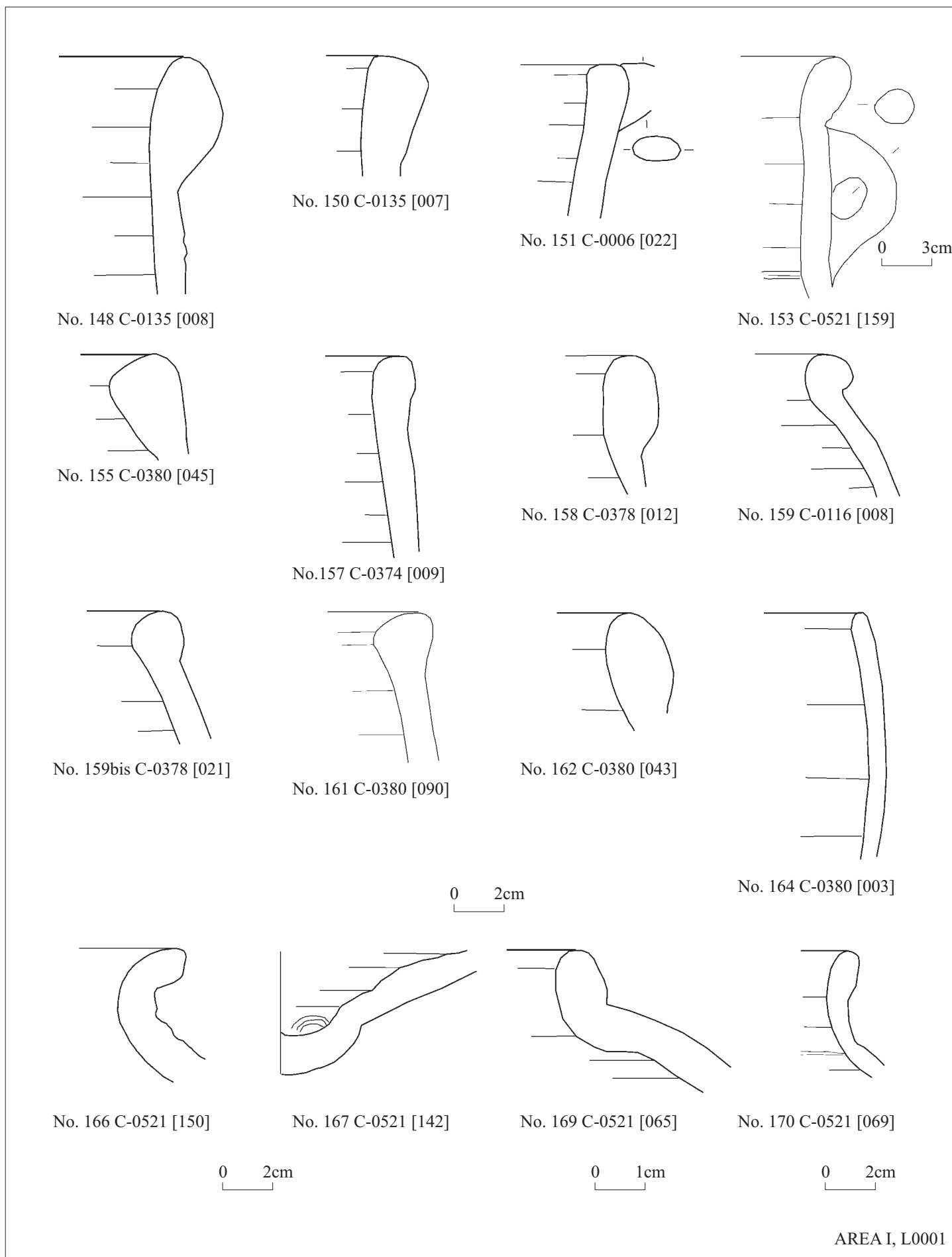
0 2cm



No. 147 C-0614[001]

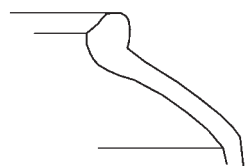
AREA I, L0001

Fig. 40:11

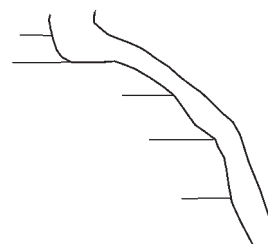


AREA I, L0001

Fig. 40:12

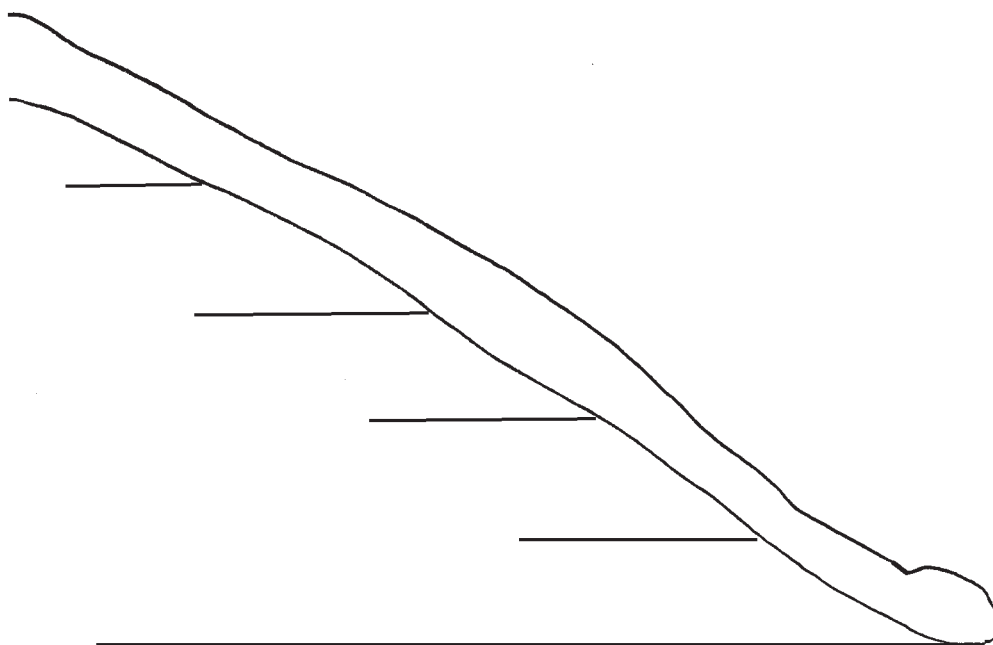


No. 172 C-0374 [013]



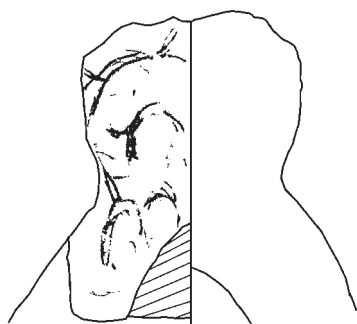
No. 174 C-0521 [134]

0 2cm



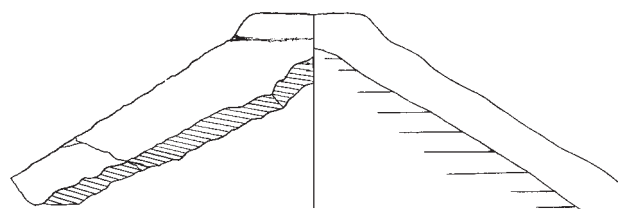
No. 179 C-0521 [029]

0 1cm



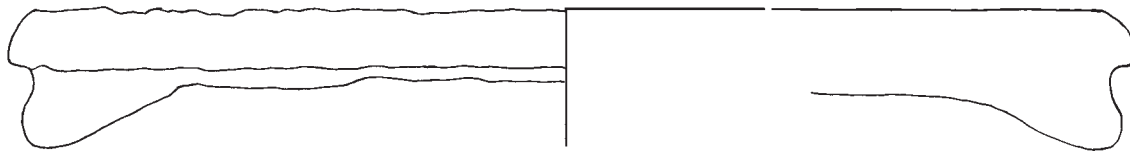
No. 180 P7049A

0 1cm



No. 181 P0032A

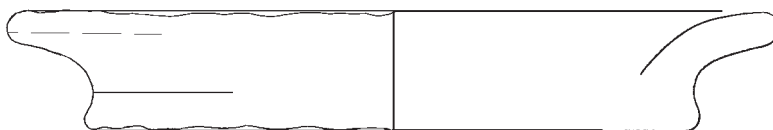
0 2cm



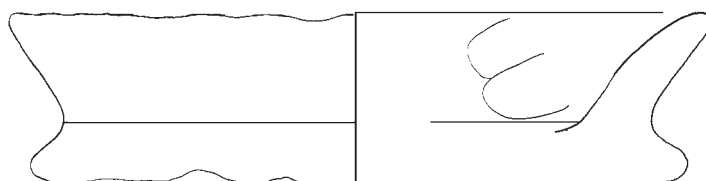
No. 182 P0098A



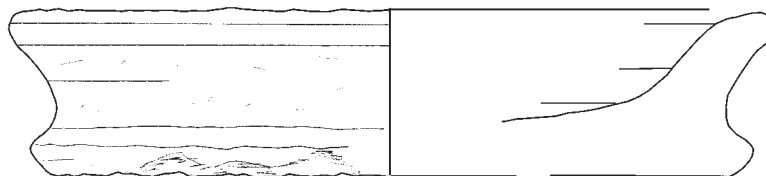
No. 183 P0571A



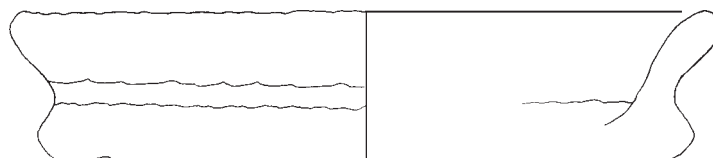
No. 184 P0632A



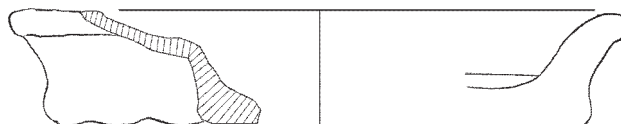
No. 185 P0631A



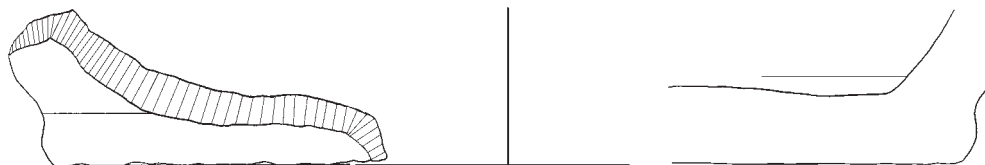
No. 186 P1003A



No. 187 P0585A



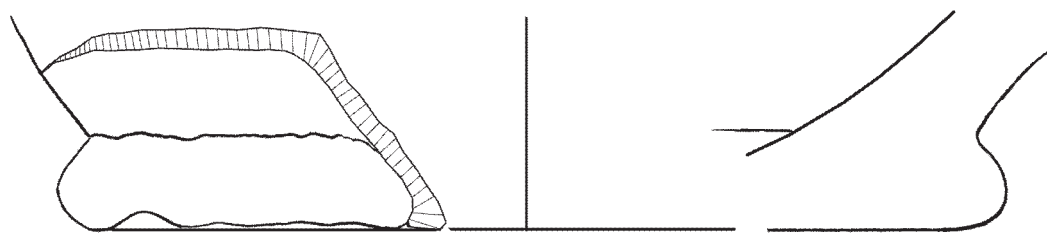
No. 188 P0633A



No. 189 P0630A

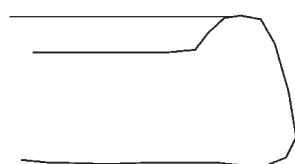
0 2cm

Fig. 40:14

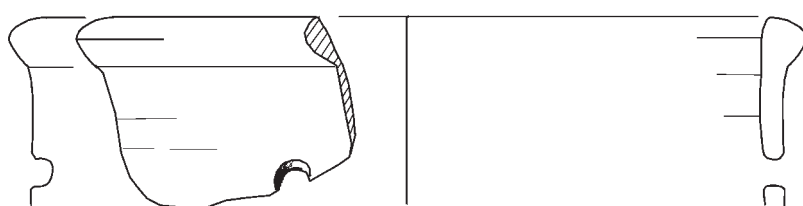


No. 191 P0600A

0 1cm



No. 192 C-0521 [014]



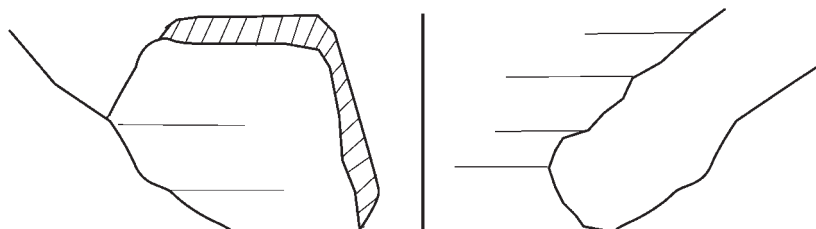
No. 193 P7062A

0 3cm



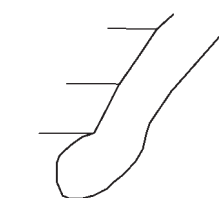
No. 194 C-0521 [146]

0 2cm



No. 195 P0017A

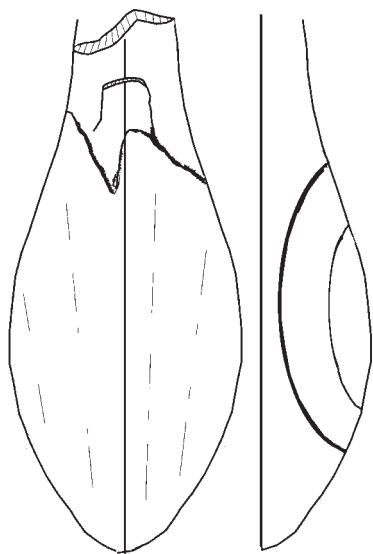
0 1cm



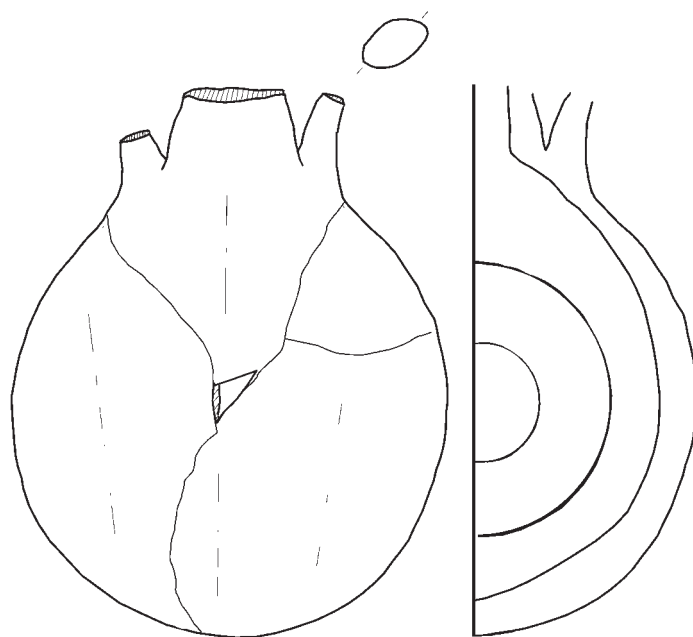
No. 196 C-0117 [016]

0 2cm

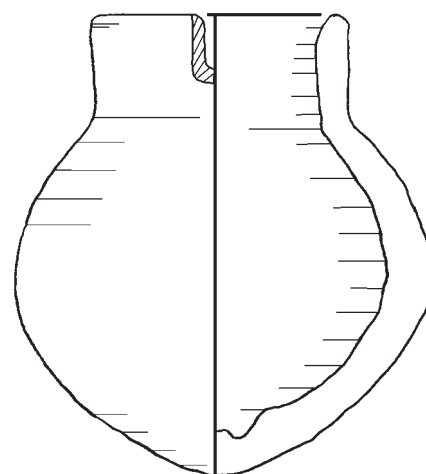
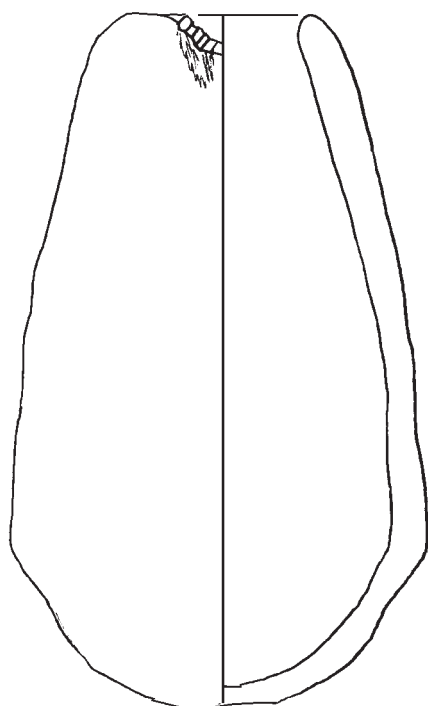
Fig. 40:15



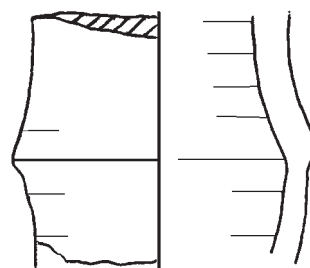
No. 199 P0638A



No. 197 P0623A

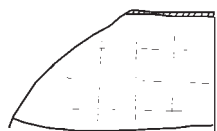


No. 200 P0013A



No. 201 P7019A

0 1cm



No. 203 P7099A

0 2cm



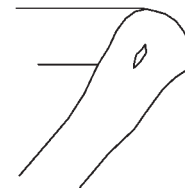
No. 204 C-0521 [139]

0 1cm

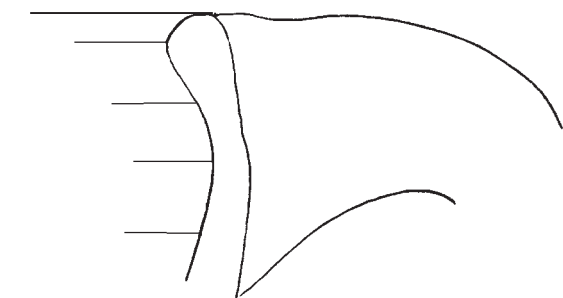


No. 205 C-0521 [157]

0 2cm



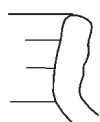
No. 206 C-0521 [050]



No. 208 P7048A

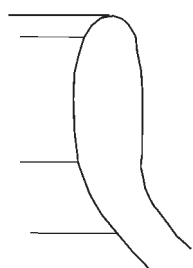


0 1cm



No. 209 C-0521 [025]

0 2cm

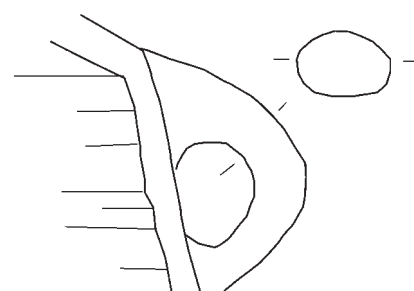


No. 211 C-0521 [138]

0 1cm

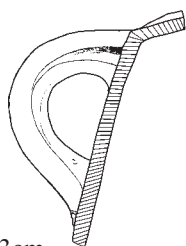


No. 212 C-0521 [133]



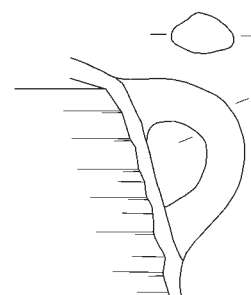
No. 216 C-0521 [153]

0 2cm



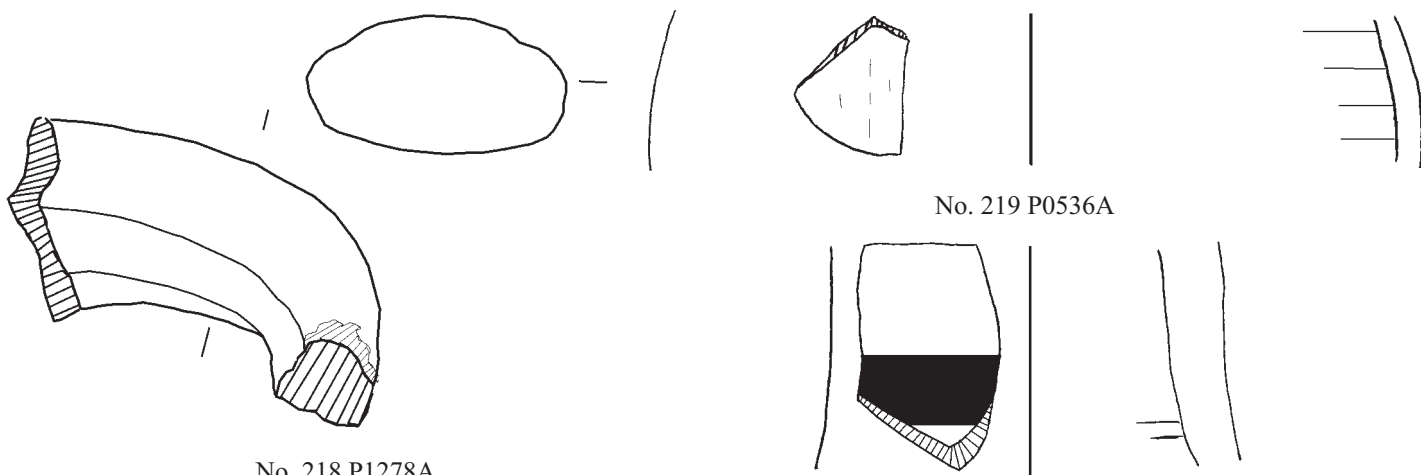
0 3cm

No. 217 C-0521 [135]



AREA I, L0001

Fig. 40:17

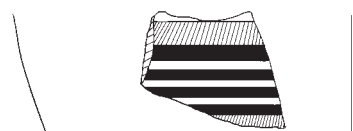


No. 218 P1278A

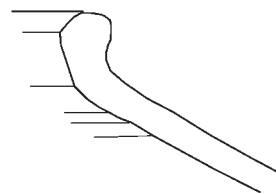
No. 219 P0536A

No. 220 P1282A

0 1cm

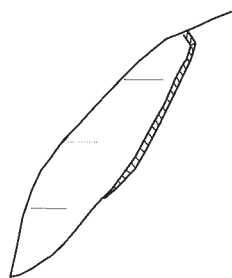


No. 221 P0016A

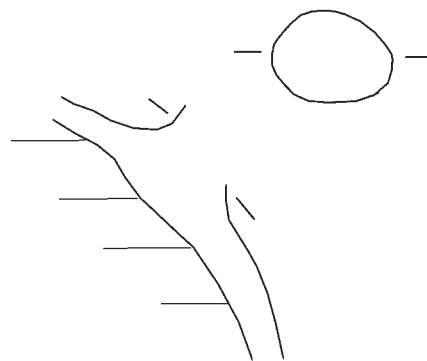


No. 224 C-0521 [105]

0 2cm

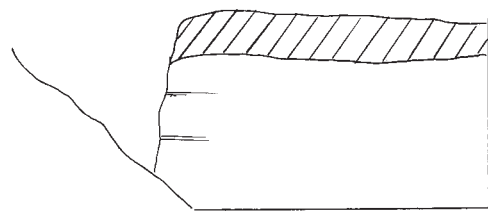


No. 222 P0843A



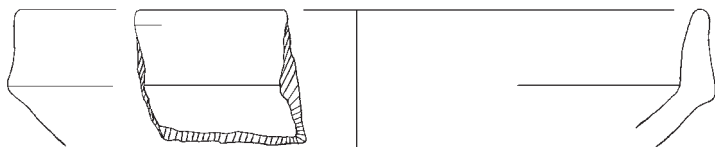
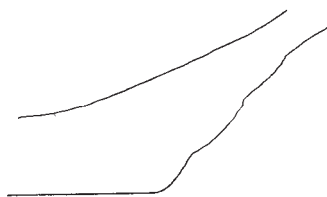
No. 225 C-0521 [104]

0 1cm



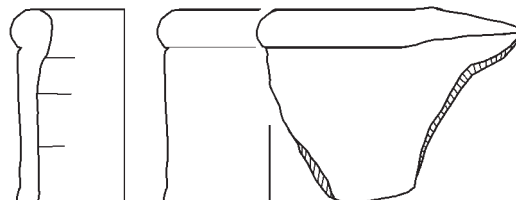
No. 233 P7090A

0 2cm



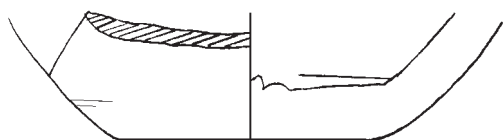
No. 234 P1279A

0 2cm

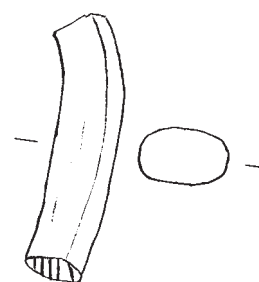


No. 235 P0139A

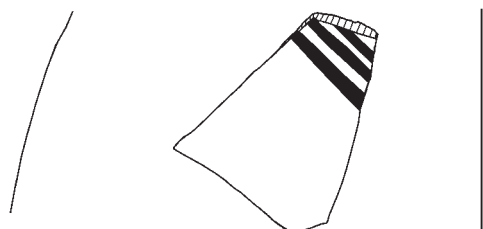
0 1cm



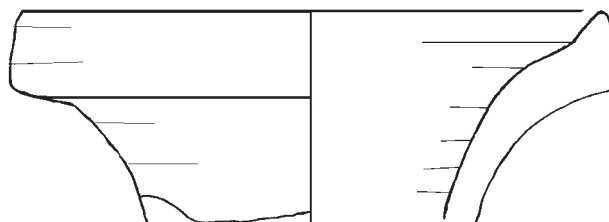
No. 237 P1052A



No. 238 P0777A

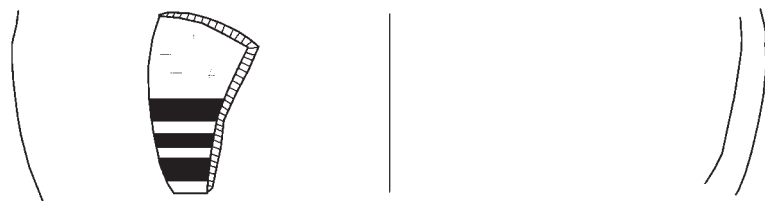


No. 239 P1177A



No. 240 P0799A

0 1cm



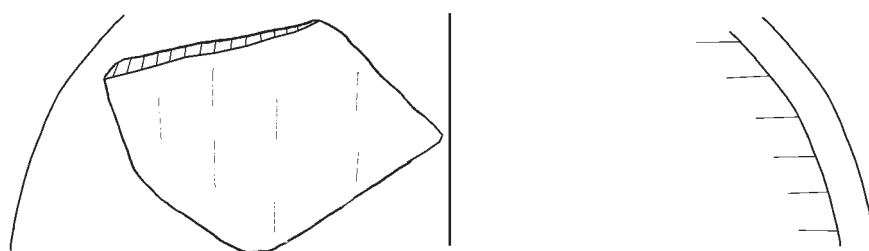
No. 241 P0805A

0 2cm



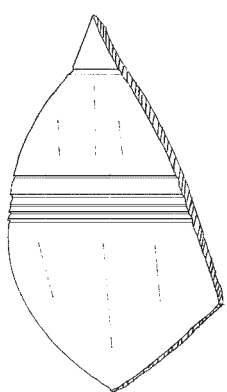
No. 242 P0227A

0 1cm

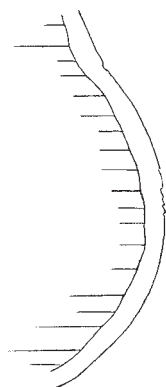


No. 243 P0839A

0 2cm

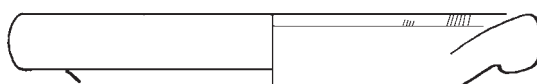


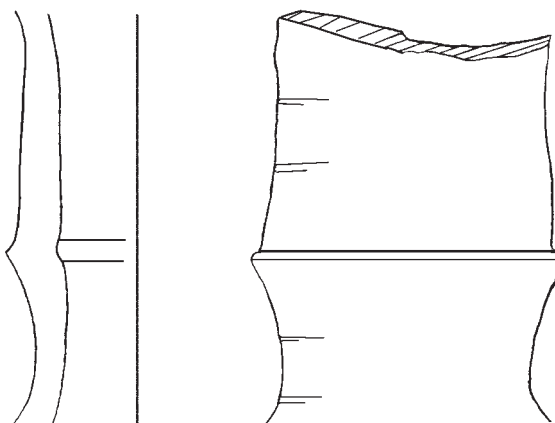
No. 244 P1268A



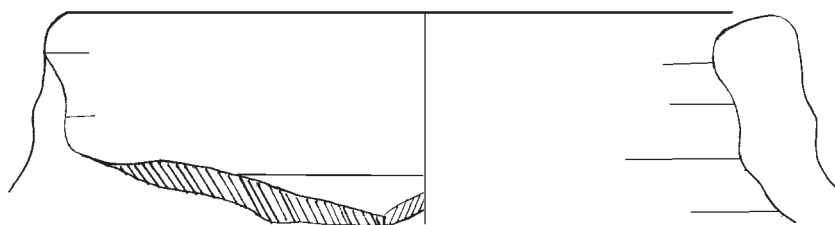
No. 245 P0518A

0 1cm



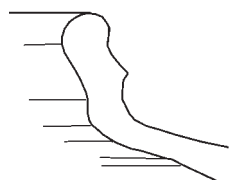


No. 246 P1065A



No. 247 P0850A

0 1cm

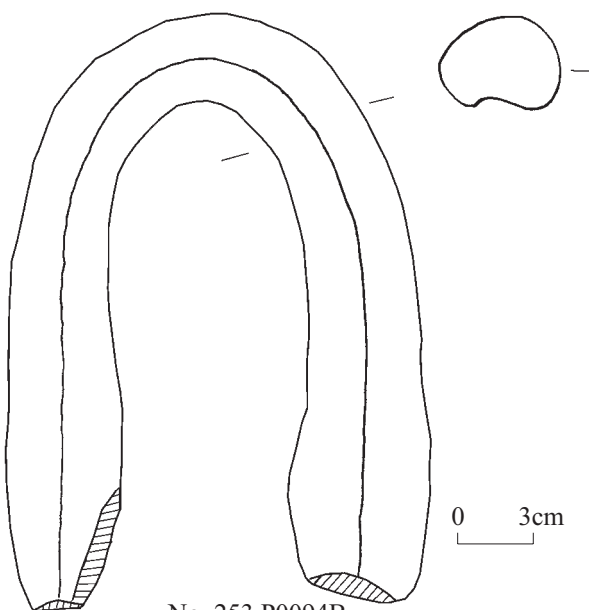


No. 248 C-0521 [090]



No. 250 P1070A

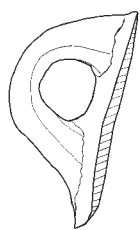
0 2cm



No. 253 P0094B

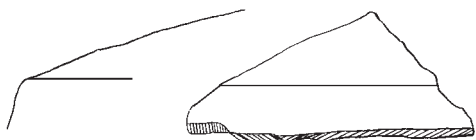
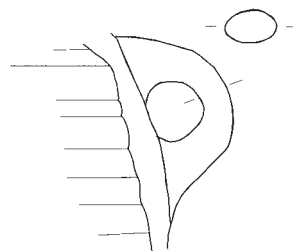
0 3cm

AREA I, L0001

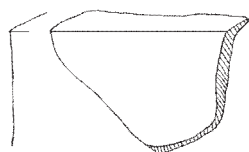
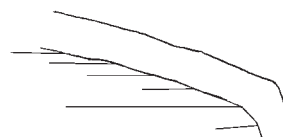


No. 254 P0115A

0 3cm

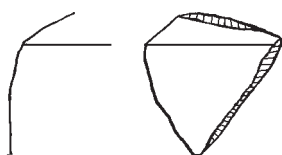


No. 259 P1069A



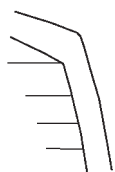
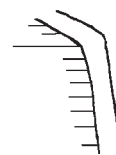
No. 260 P1049A

0 2cm

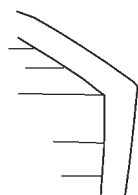


No. 261 P0163A

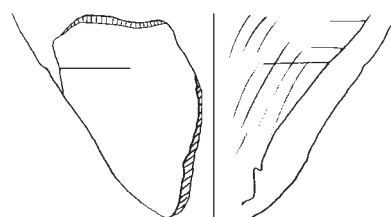
0 3cm



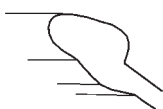
No. 262 C-0521 [100]



No. 263 C-0380 [091]



No. 265 P0162A



No. 267 C-0521 [102]



No. 268 C-0521 [099]



No. 274 C-0521 [122]

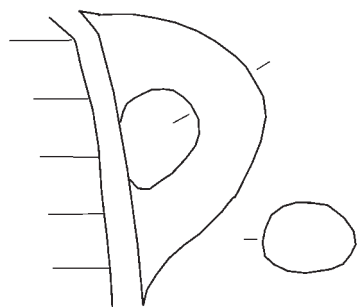


No. 275 C-0521 [124]

0 2cm

AREA I, L0001

Fig. 40:22

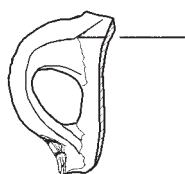


No. 276 C-0521 [125]



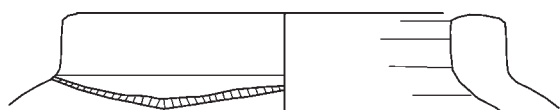
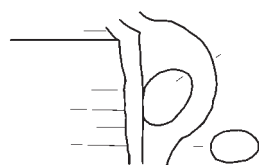
No. 277 C-0379 (2) [001]

0 2cm

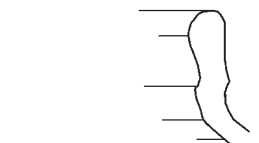


No. 278 P1289A

0 3cm



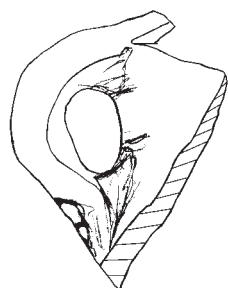
No. 282 P7037A



No. 284 C-0521 [120]



No. 286 P0071A



No. 287 P1288A

0 2cm

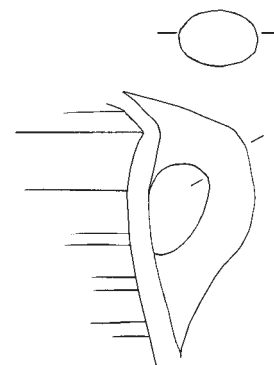
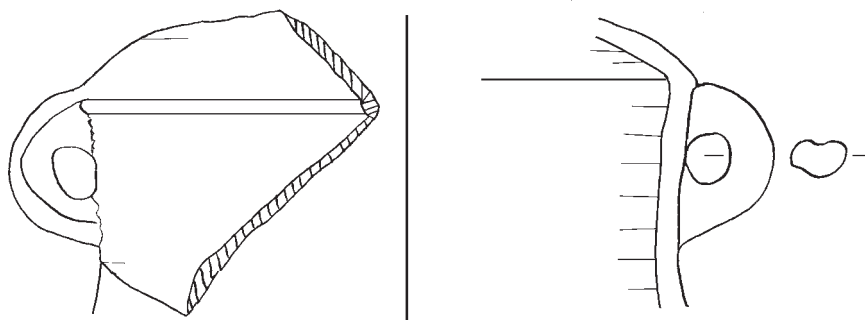
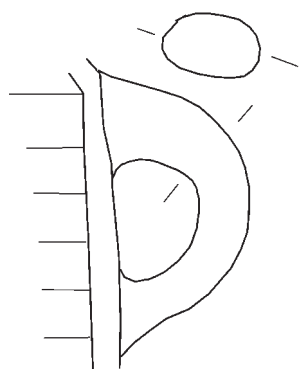


Fig. 40:23

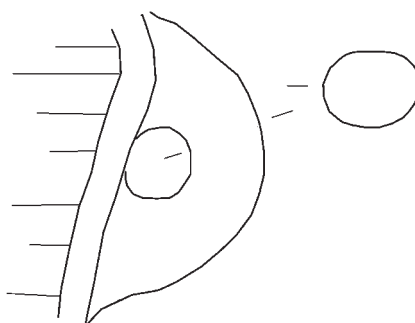


No. 288 P0095B

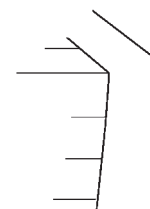
0 3cm



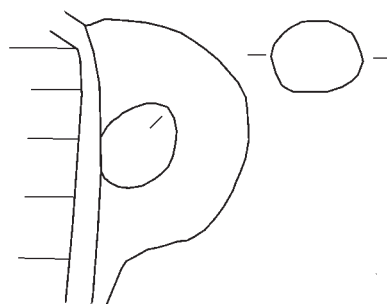
No. 289 C-0521 [119]



No. 290 C-0380 (2) [001]



No. 291 C-0135 [024]

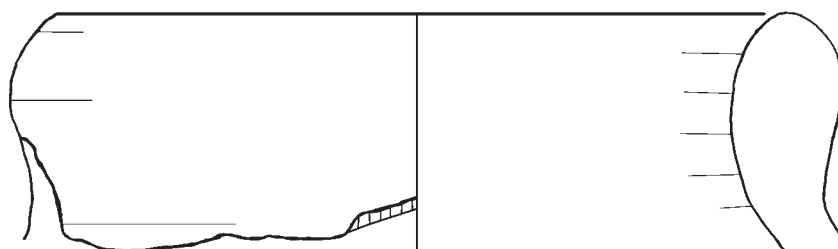


No. 292 C-0521 [013]



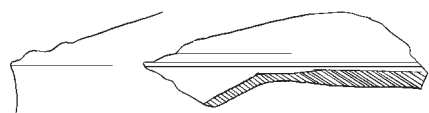
No. 296 C-0006 [019]

0 2cm

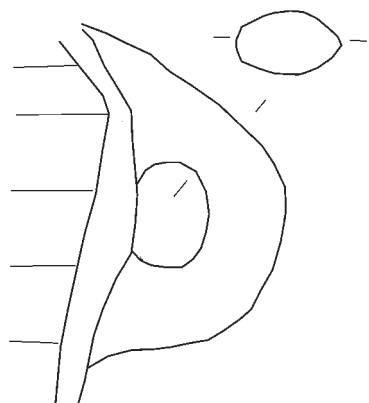


No. 303 P0381A

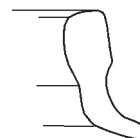
0 1cm



No. 304 P1048A

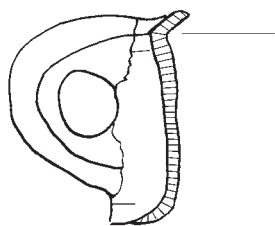


No. 305 C-0521 [097]



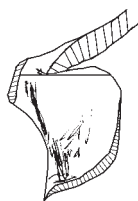
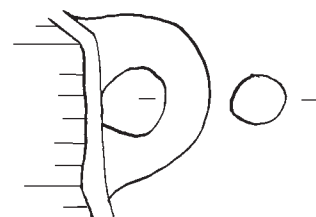
No. 310 C-0135 [004]

0 2cm



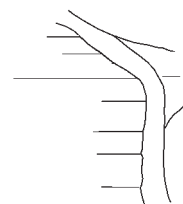
No. 311 P0353A

0 3cm



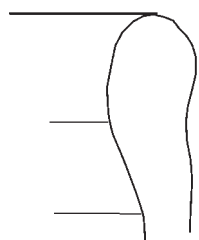
No. 312 P1295A

0 2cm



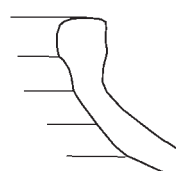
No. 317 C-0055 [007]

0 2cm



No. 318 C-0039 [002]

0 1cm



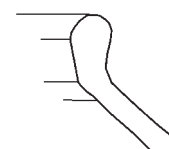
No. 319 C-0521 [106]

0 2cm



No. 325 C-0521 [126]

0 1cm

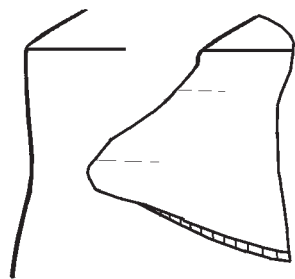


No. 326 C-009 (2) [002]

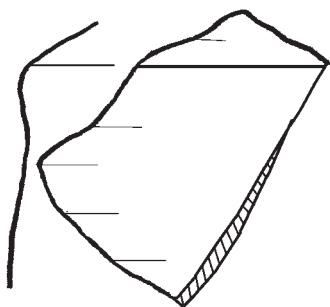
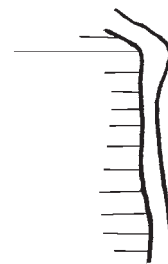
0 2cm

AREA I, L0001

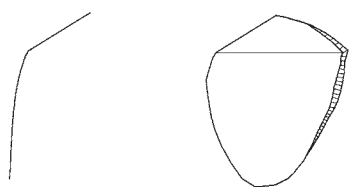
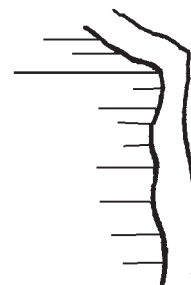
Fig. 40:25



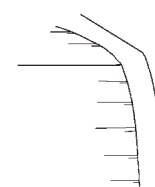
No. 329 P0174A



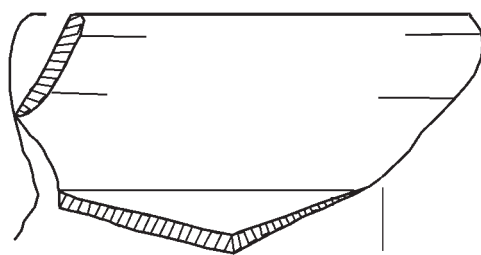
No. 330 P0884A



No. 331 P0089A

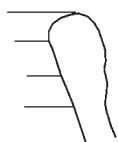


0 2cm



No. 333 P1294A

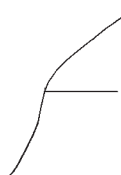
0 1cm



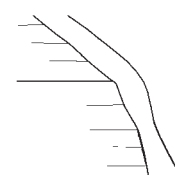
No. 334 C-0521 [116]



No. 335 C-0521 [114]



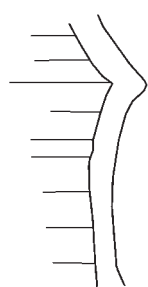
No. 337 P1146A



0 2cm

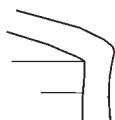
AREA I, L0001

Fig. 40:26

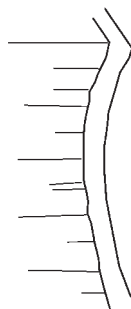


No. 339 C-0521 [112]

0 2cm

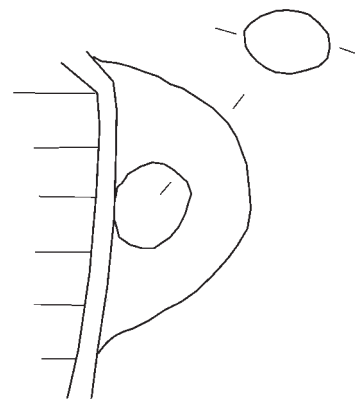


No. 340 C-0521 [113]



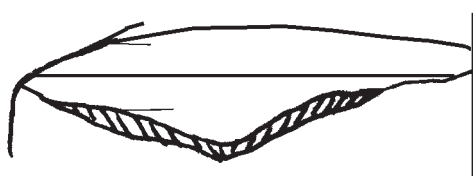
No. 341 C-0521 [165]

0 3cm



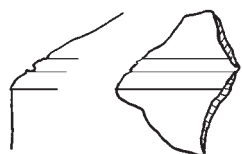
No. 343 C-0521 [111]

0 2cm



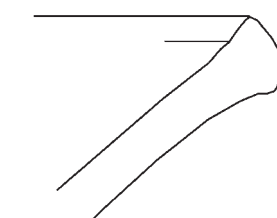
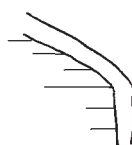
No. 346 P0883A

0 2cm



No. 347 P0099A

0 3cm



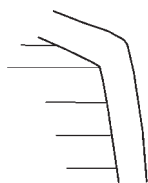
No. 348 C-0028 [001]

0 2cm

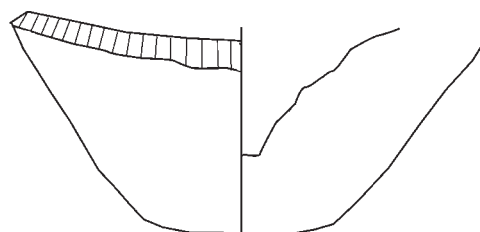


No. 349 C-0117 [003]

0 1cm



No. 350 C-0521 [089]



No. 352 P0078A

0 2cm

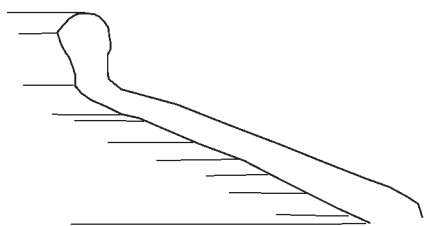


No. 354 C-0378 [004]

Fig. 40:27



No. 362 C-0015 [009]

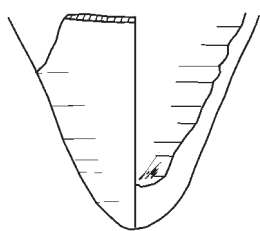


No. 364 C-0521 [080]

0 2cm

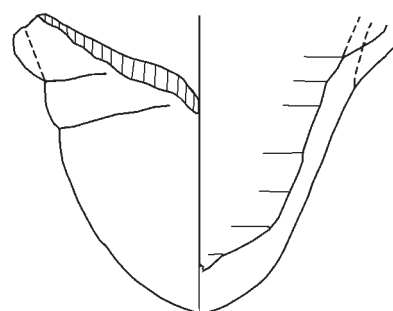


No. 365 C-0003 [010]



No. 369 P7020A

0 2cm



No. 370 P0525A

0 1cm



No. 371 P0517A



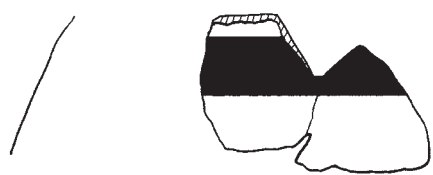
No. 372 P1031A



No. 373 P1176A

0 2cm

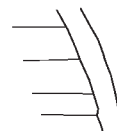
Fig. 40:28



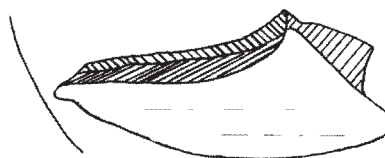
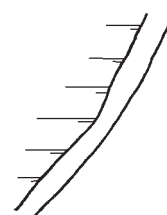
No. 375 P0220A



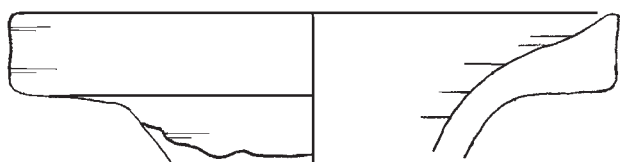
No. 376 P0807A



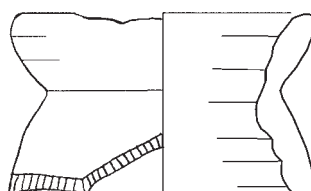
No. 378 P0200A



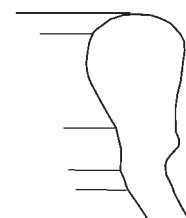
No. 379 P0394A



No. 380 P0842A



No. 381 P1068A



No. 385 C-0521 [087]

0 1cm



No. 391 P0392A



No. 392 P0712A

0 2cm

Fig. 40:29

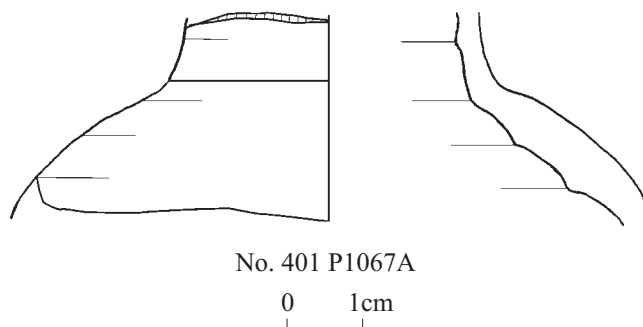
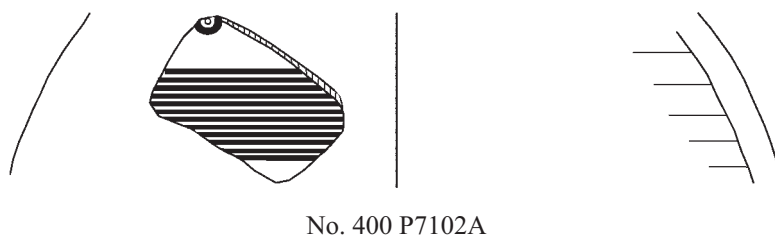
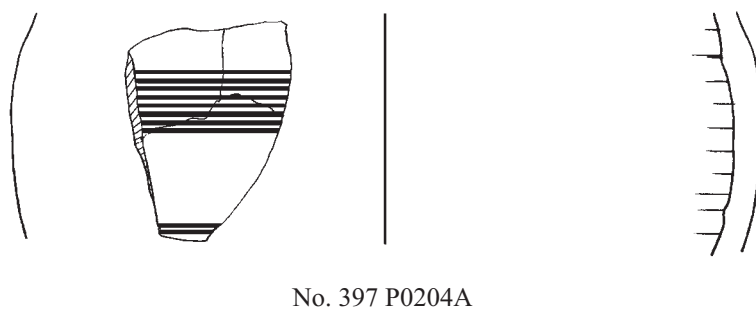
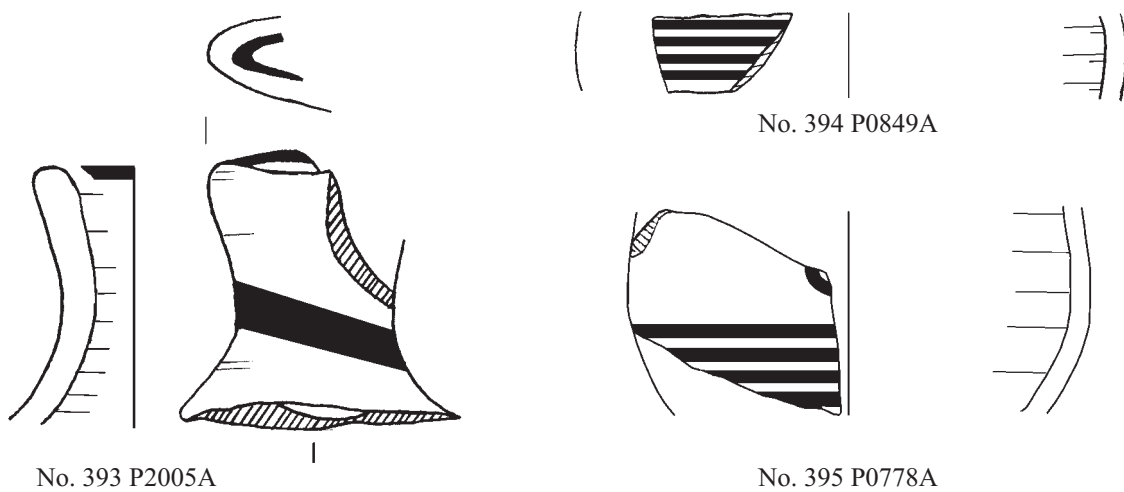
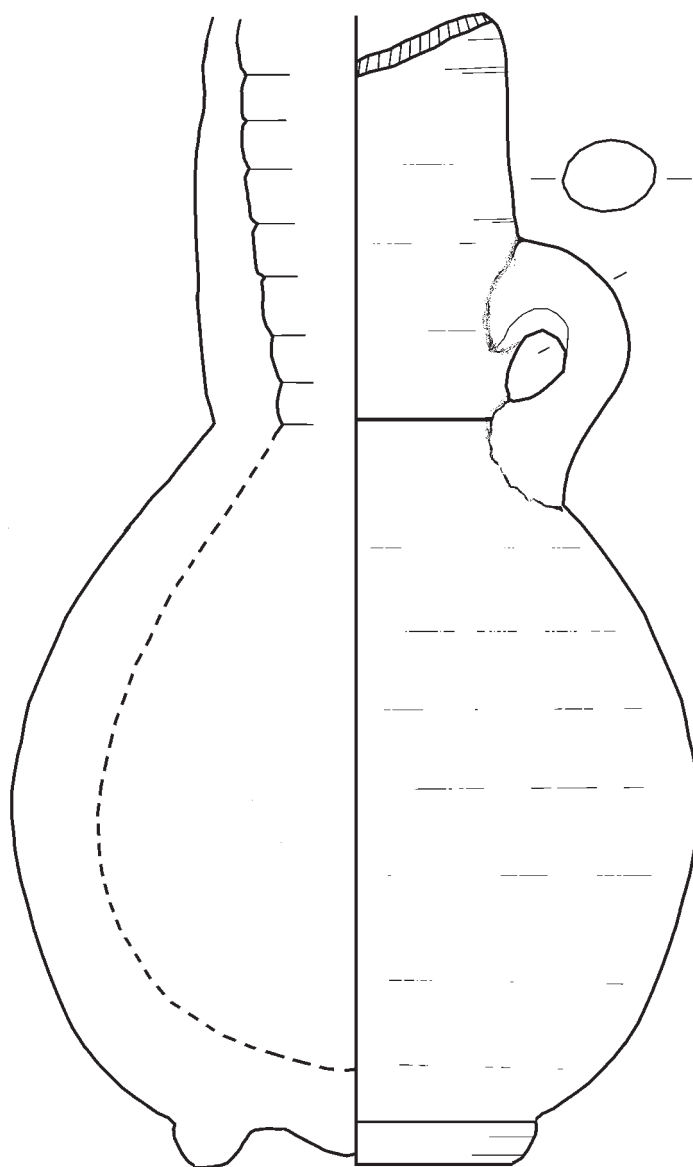
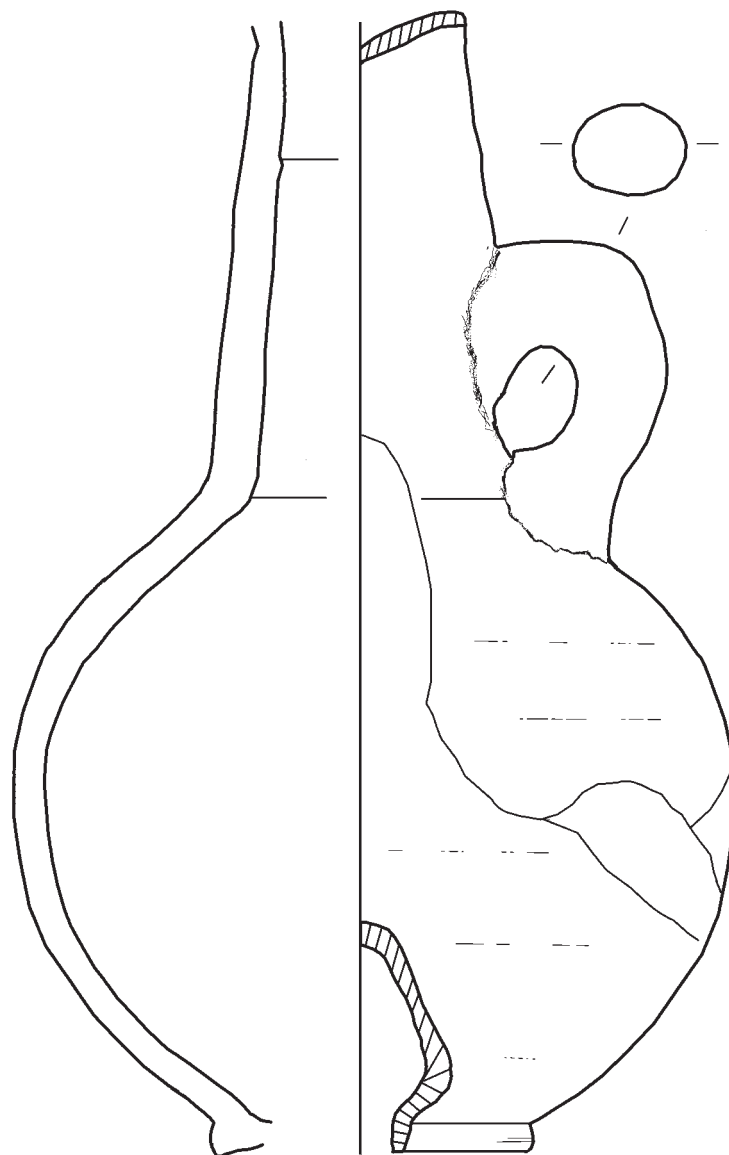


Fig. 40:30



No. 402 P0692A

0 1cm



No. 403 P0691A

0 1cm

AREA I, L0001

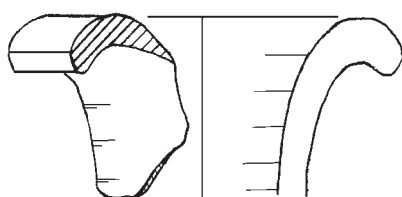
Fig. 40:32



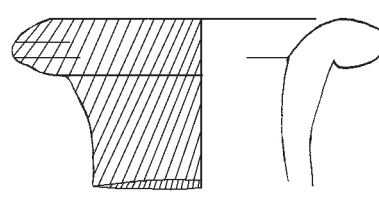
No. 404 P0067A



No. 405 P2003A



No. 406 P0732A



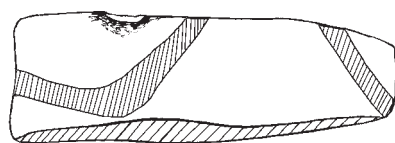
No. 407 P0207A₁₋₂



0 1cm



No. 411 P0527A



No. 413 P0048A



No. 414 C-0521 [121]

0 2cm

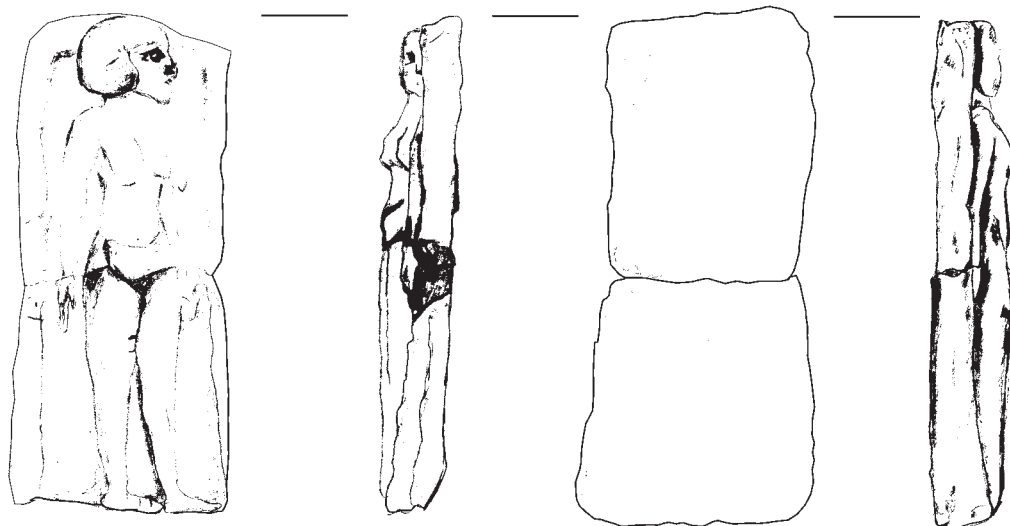
Fig. 40:33



No. 416 F0179 + F0475

AREA I, L0001

Plate 13

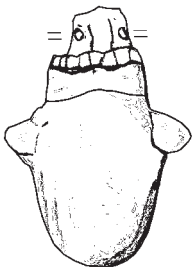


No. 416 F0179 + F0475

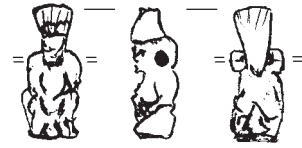
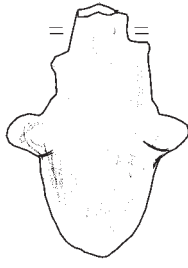
0 2cm

AREA I, L0001

Fig. 40:34



No. 417 F0494



No. 419 F0004



No. 423 F0064



No. 418 F0614



Plate 14



No. 420 F0158



Plate 15



No. 421 F0515A



Plate 16



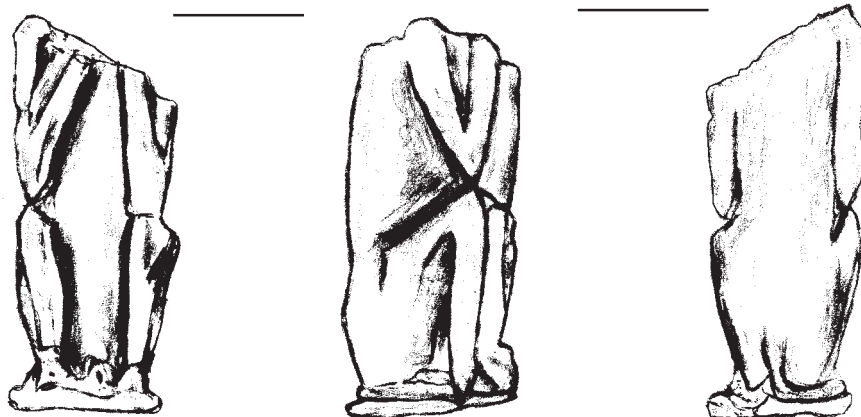
No. 422 F0034

0 1cm



Plate 17

Fig. 40:35



No. 424 F0499

0 1cm



Plate 18

AREA I, L0001

Fig. 40:36



No. 425 F0006A
19



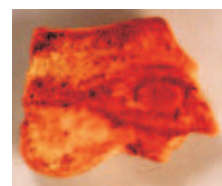
No. 426 F0007A
20



No. 427 F0066A
21



No. 428 F0125A
22



No. 429 F0151
23

AREA I, L0001

Plate 19 - 23



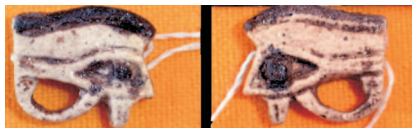
No. 431 F0154A
24



No. 432 F0174
25



No. 433 F0295A
26



No. 435 F0483
27



No. 439 F0650
28



No. 441 F0491
29

AREA I, L0001

Plates 24 -29



No. 438 F0658



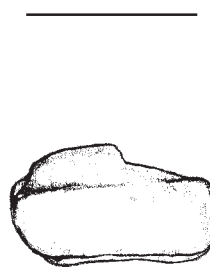
No. 440 F0655



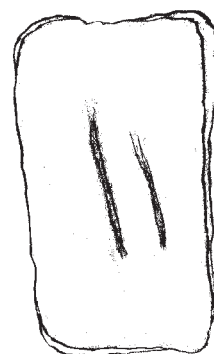
No. 442 F0492A



0 1cm

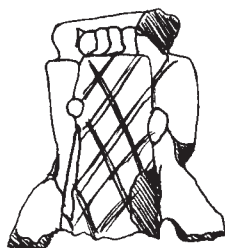


No. 444 F0436



AREA I, L0001

Fig. 40:37



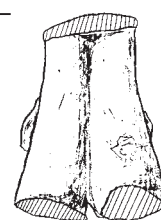
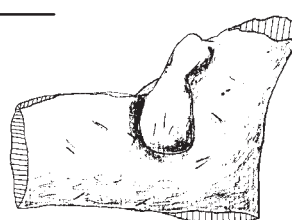
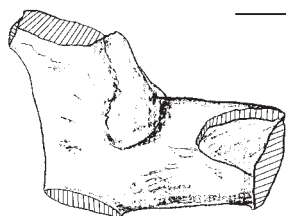
No. 445 F0150

Plate 30

0 1cm

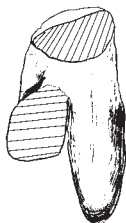
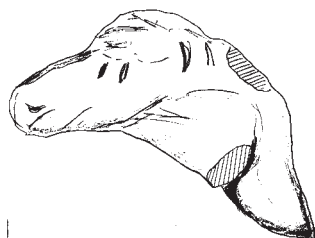


No. 446 F0292
Plate 31



No. 447 F0001

0 2cm



No. 449 F0181

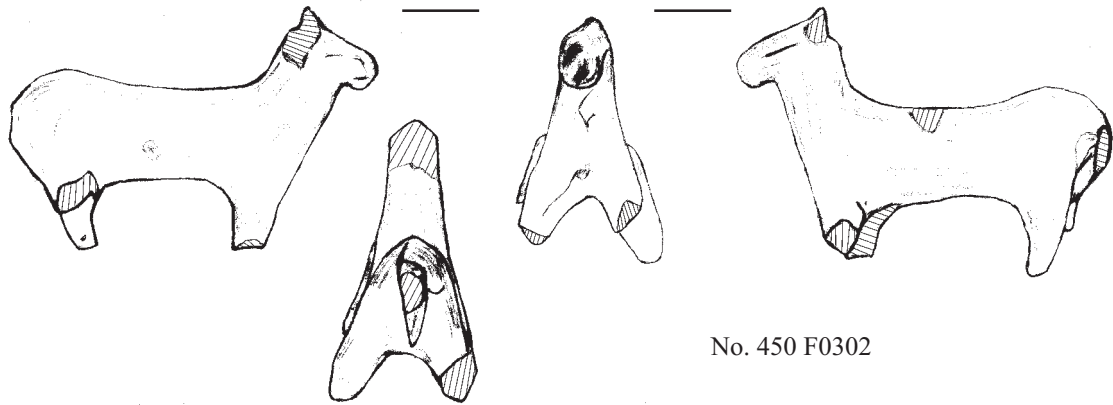
0 1cm



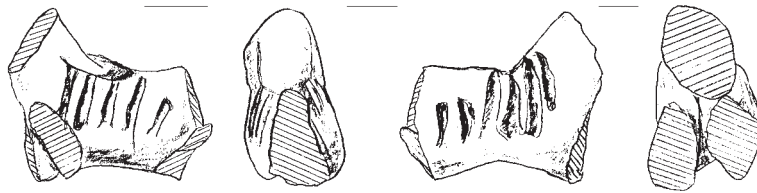
No. 448 F0840A

AREA I, L0001

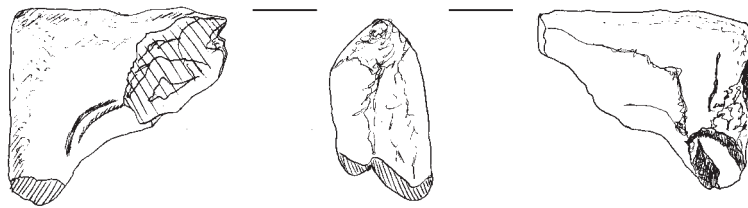
Fig. 40:38



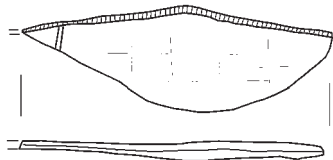
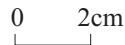
No. 450 F0302



No. 451 F0018



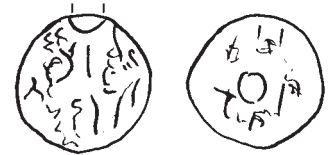
No. 452 F0170



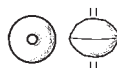
No. 453 F0177A



No. 455 F0003A



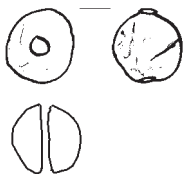
No. 457 F0037



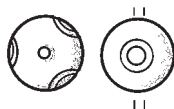
No. 458 F0038A



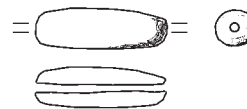
No. 456 F0005A



No. 459 F0155A



No. 460 F0171



No. 464 F0482



No. 468 F0600A



No. 469 F0609A

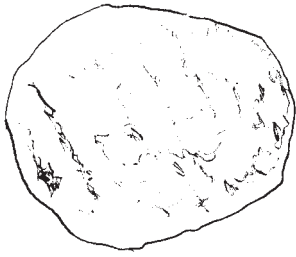


No. 470 F0172A



AREA I, L0001

Fig. 40:39



No. 471 F0062A



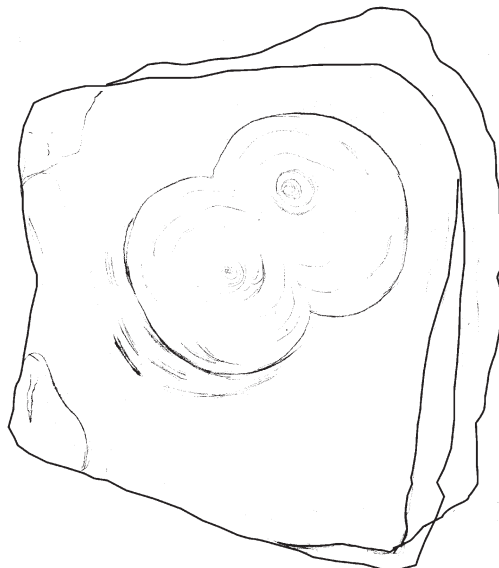
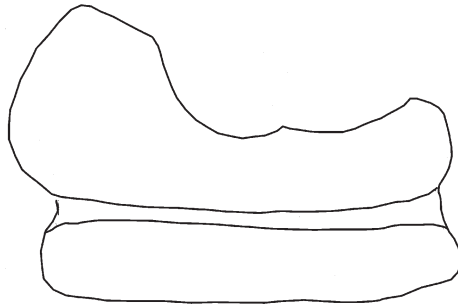
No. 474 F0134A



No. 475 F0059A



No. 476 F0060A

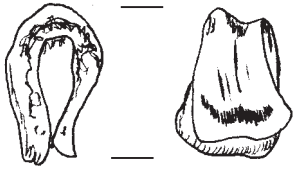


No. 480 F0539A

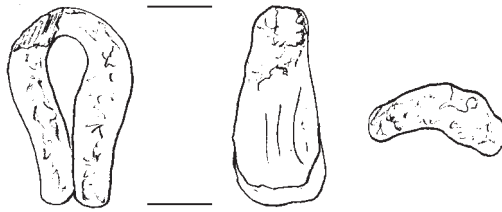
0 1cm

AREA I, L0001

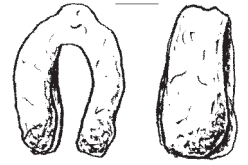
Fig. 40:40



No. 481 F0176A



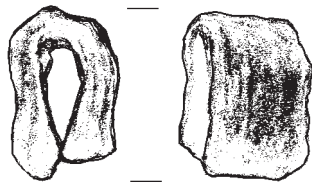
No. 482 F0188A



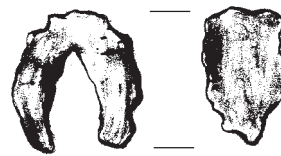
No. 484 F0467A



No. 485 F0468A



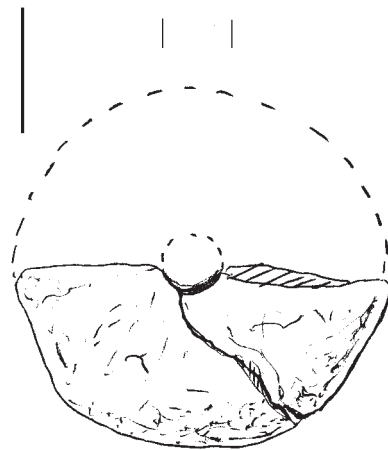
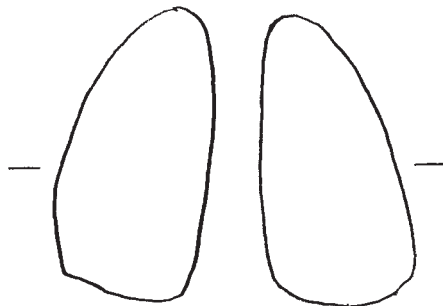
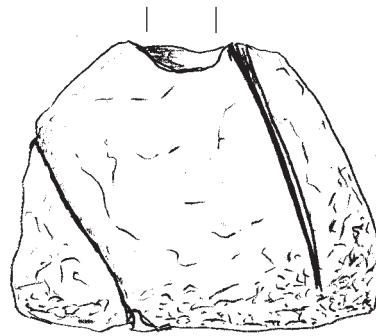
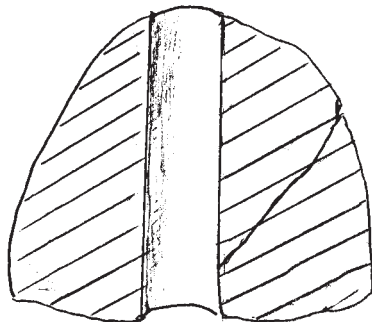
No. 488 F0737A



No. 489 F0746A



No. 491 F1021A

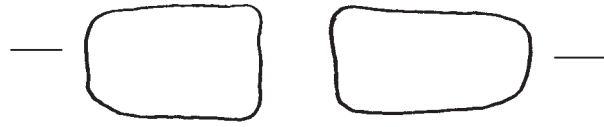
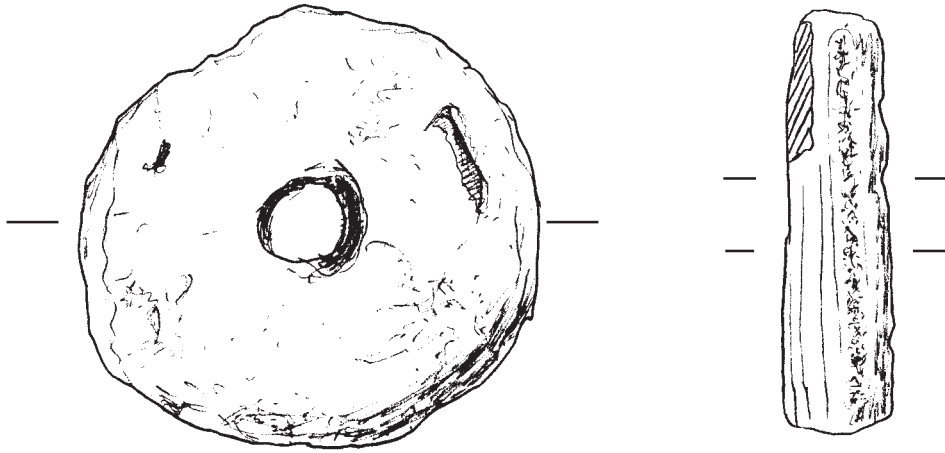


No. 492 F0157A

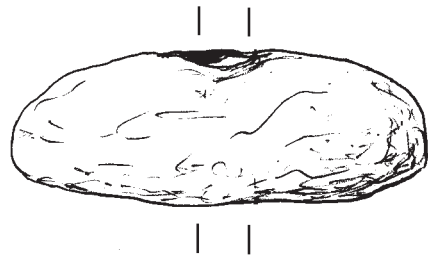
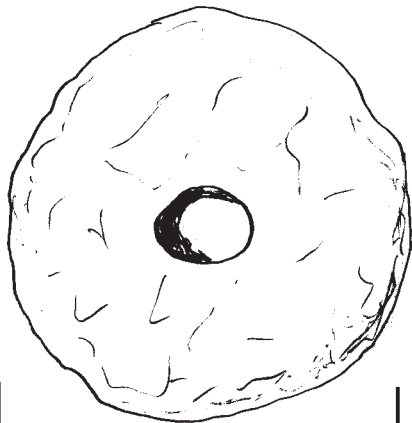
0 1cm

AREA I, L0001

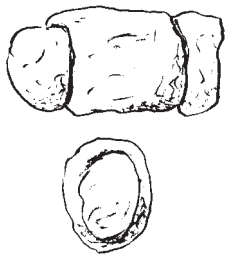
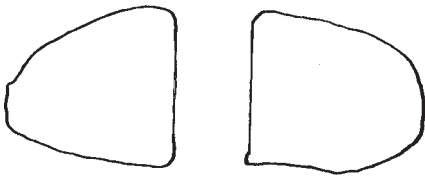
Fig. 40:41



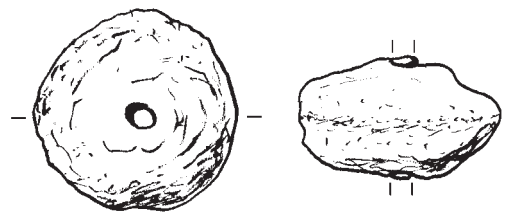
No. 493 F0162



No. 494 F0496A



No. 496 F1078A

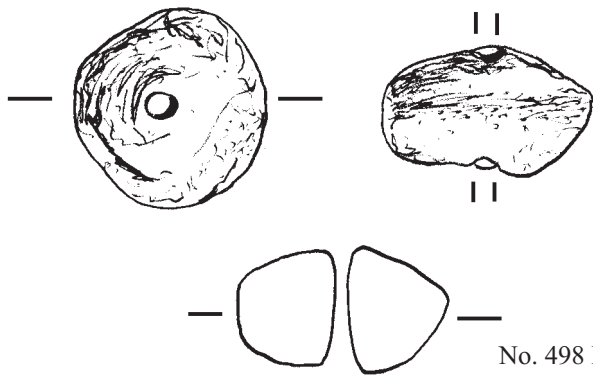


No. 497 F0035A

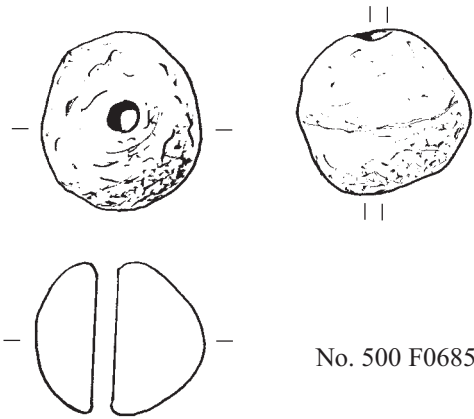
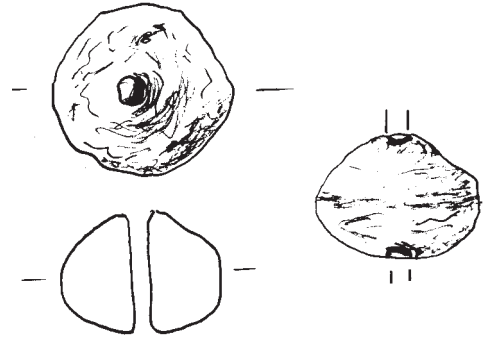
0 1cm

AREA I, L0001

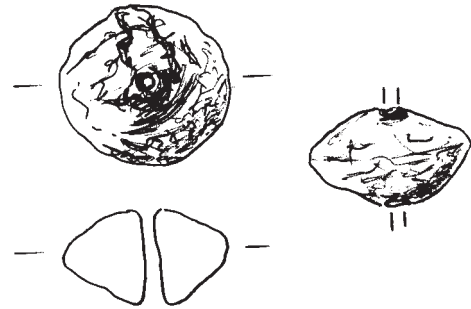
Fig. 40:42



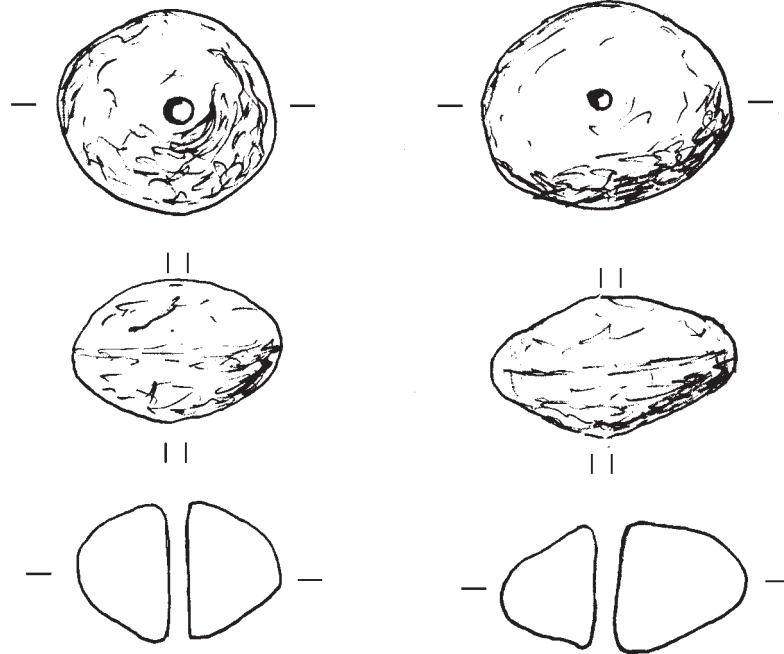
No. 498 F0169



No. 500 F0685



No. 499 F0495A_{1,2}



No. 501 F0770_{1,2}

0 1cm

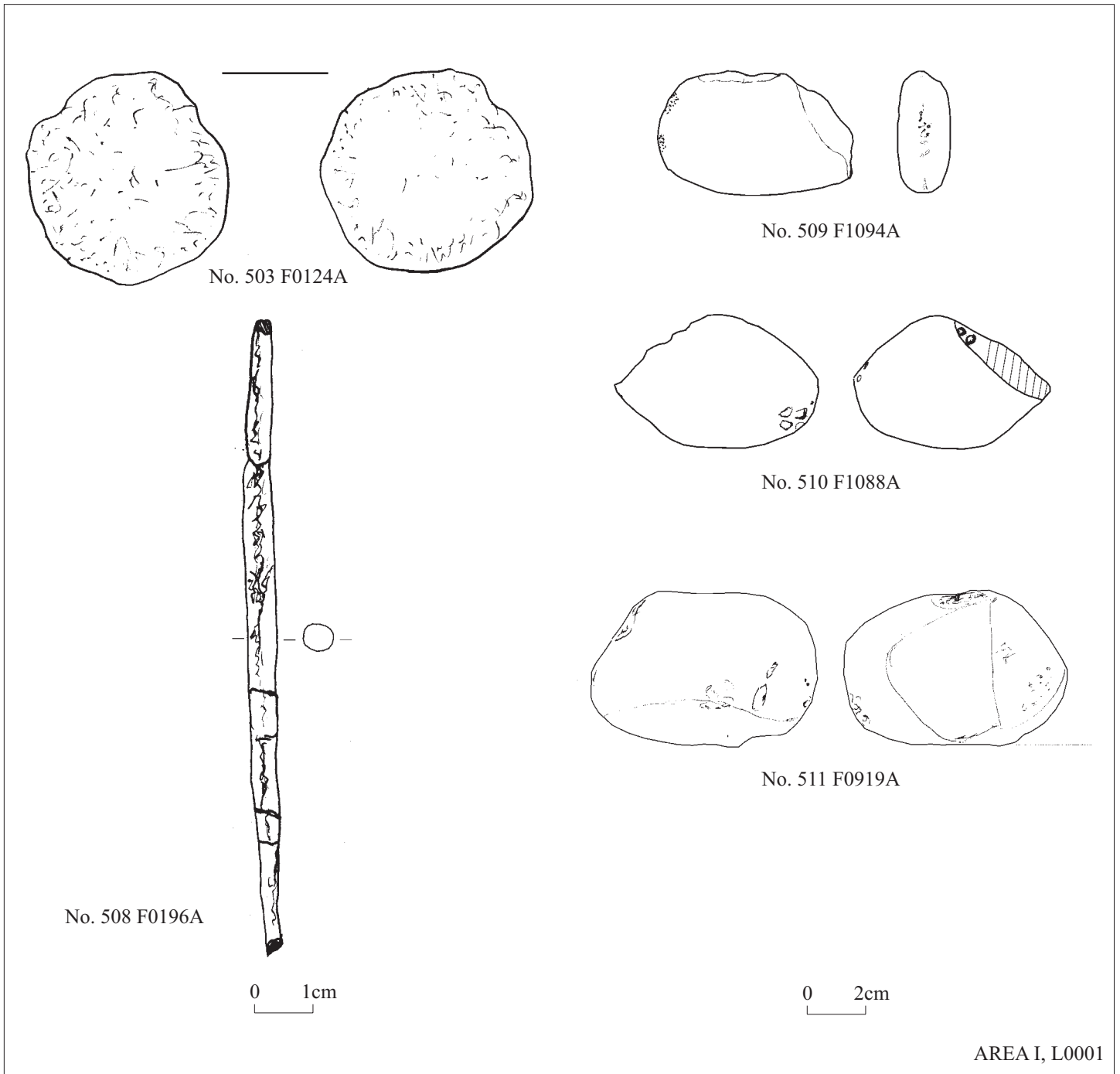
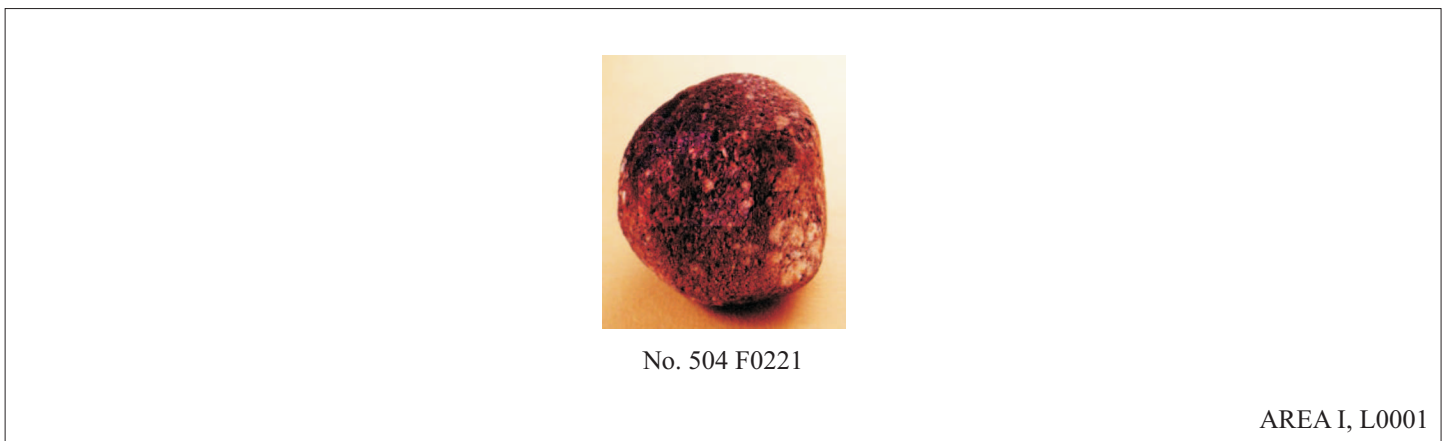


Fig. 40:44



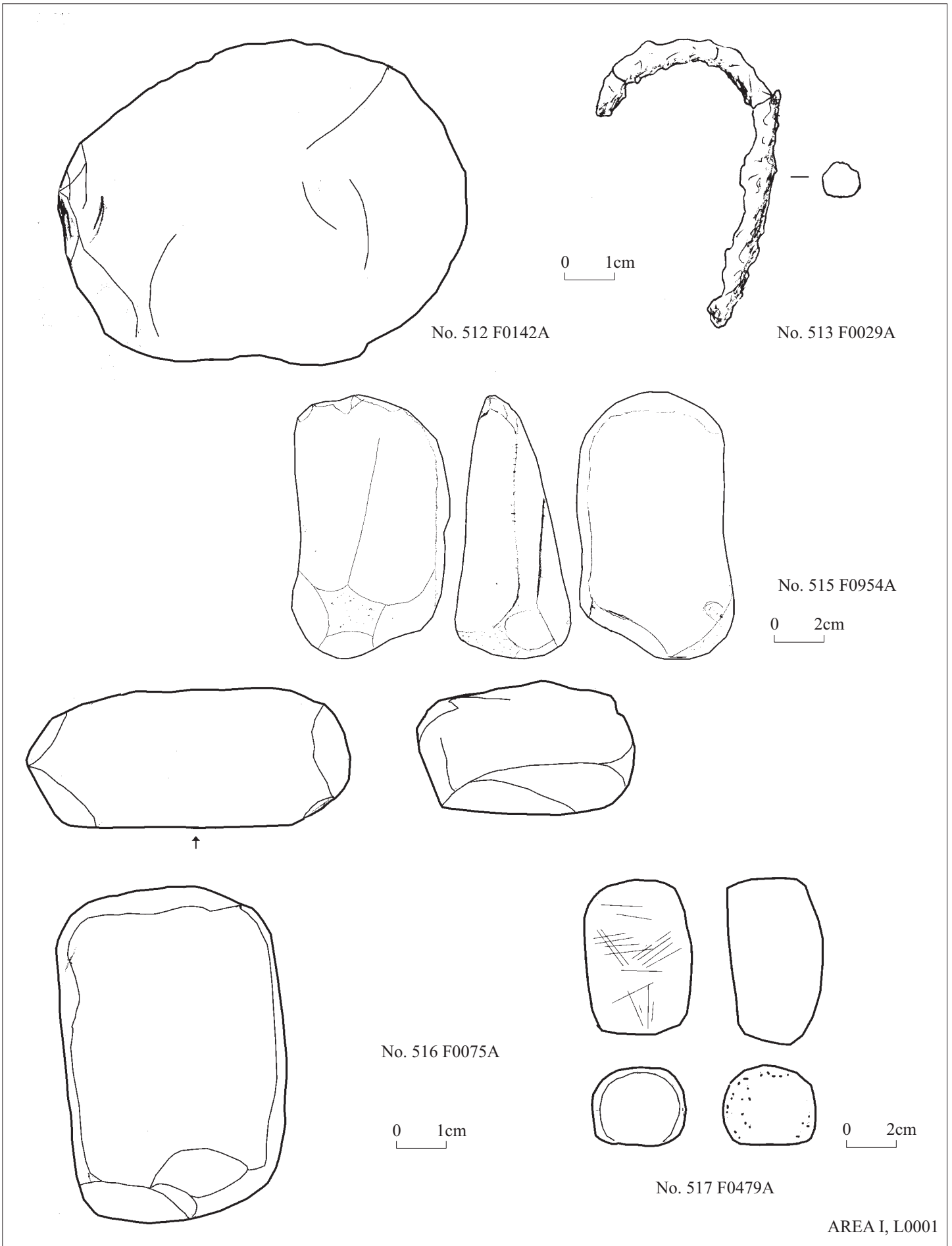
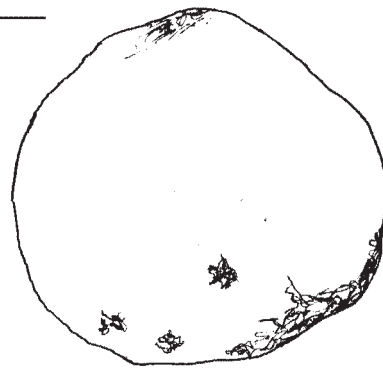
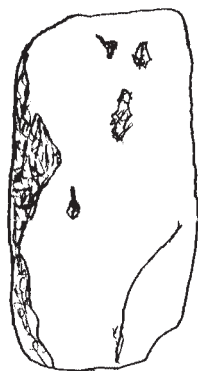
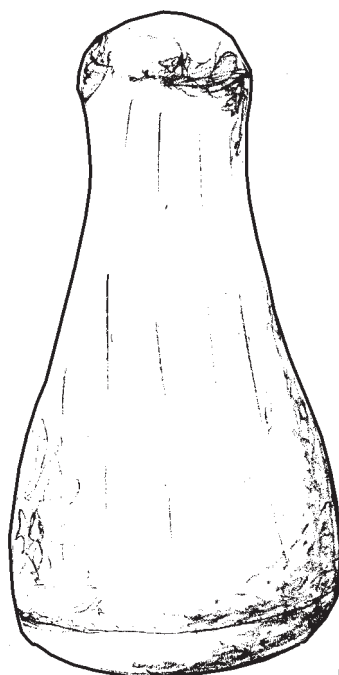


Fig. 40:45

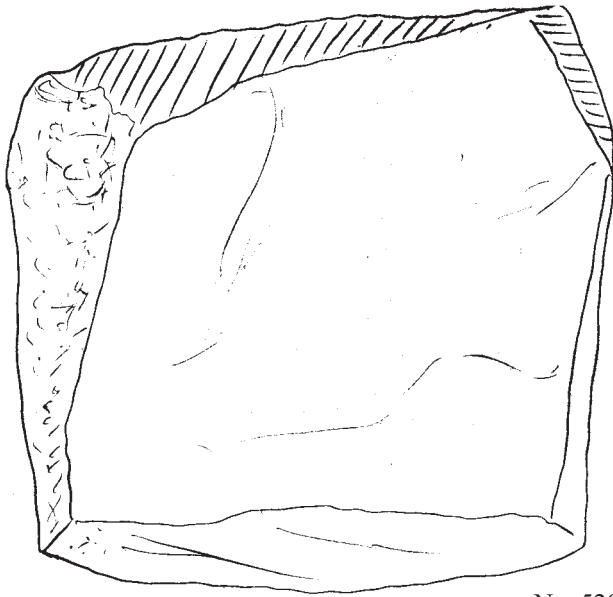


No. 518 F0180B

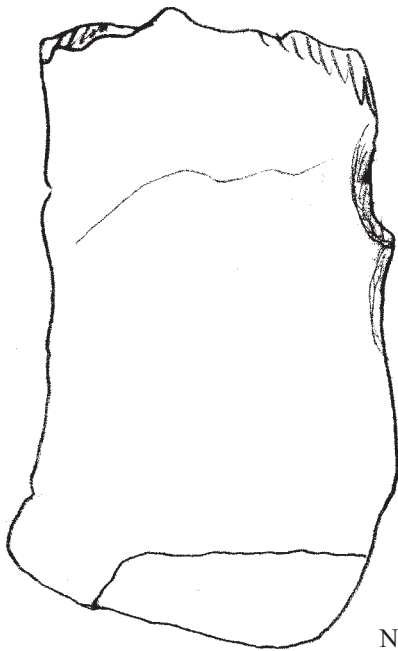
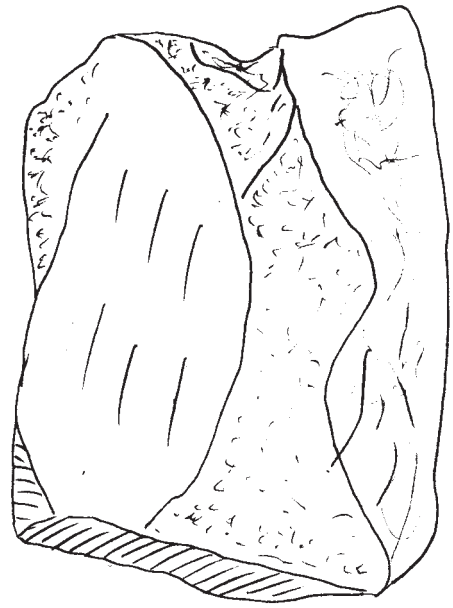


No. 519 F0040

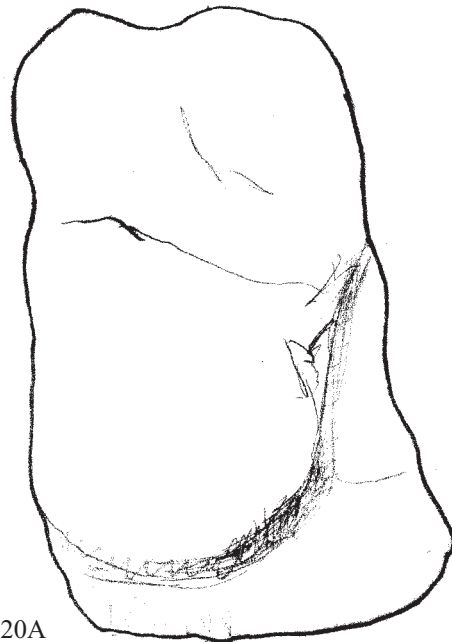
0 1cm



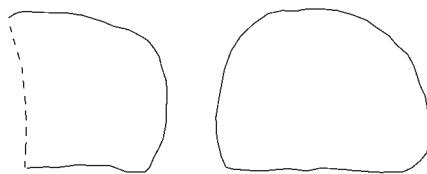
No. 520 F0168A



No. 521 F0220A

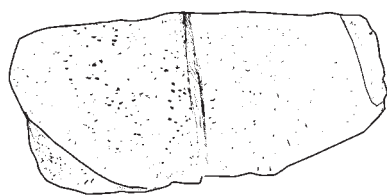
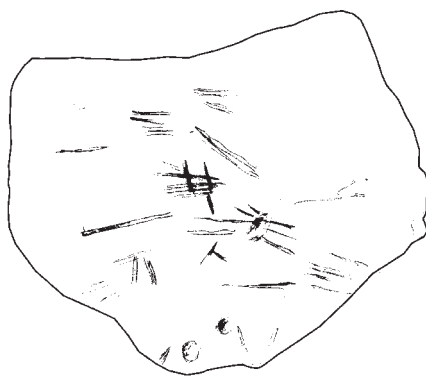


0 1cm

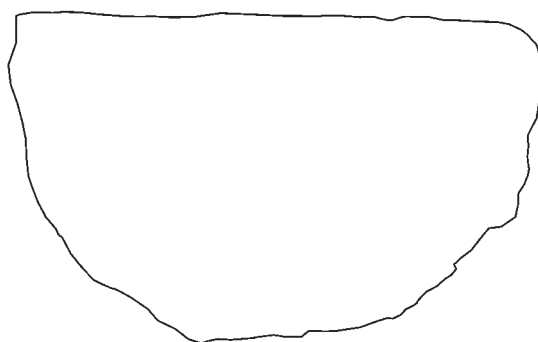
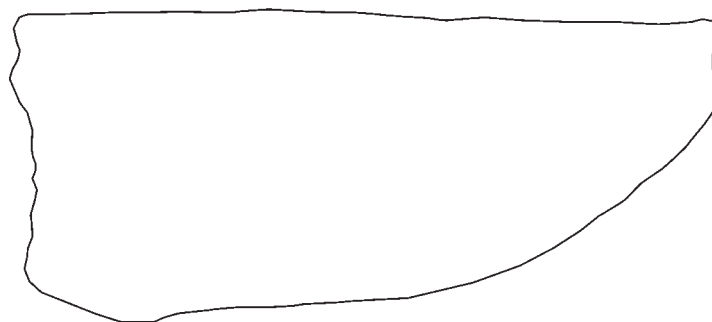


No. 522 F0984A

0 2cm

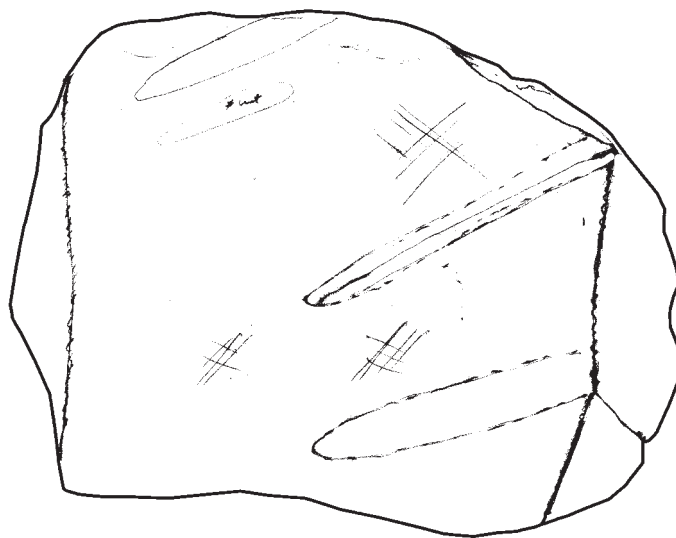


No. 523 F0501A



No. 525 F1098A

0 2cm



No. 526 F0149A

0 2cm

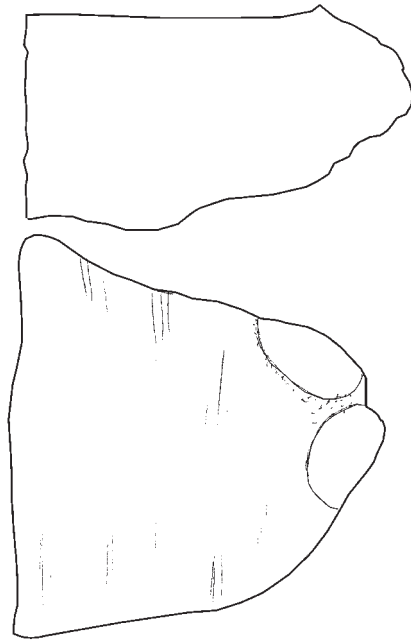


No. 528 F0167A

0 4cm

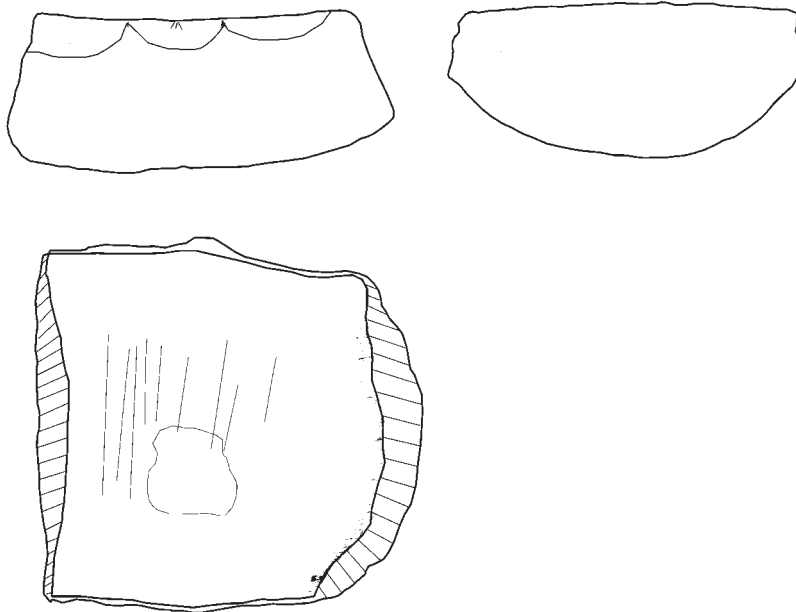
AREA I, L0001

Fig. 40:49



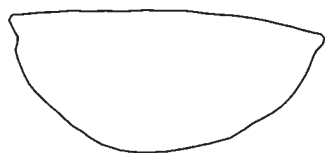
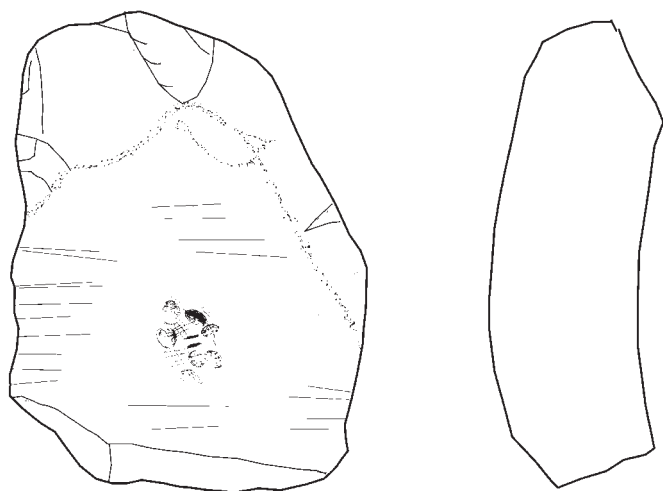
No. 529 F0236A

0 2cm



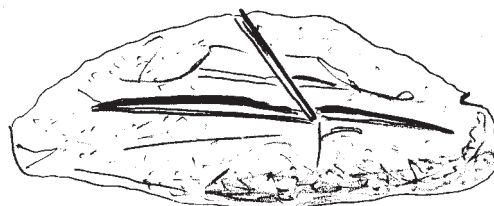
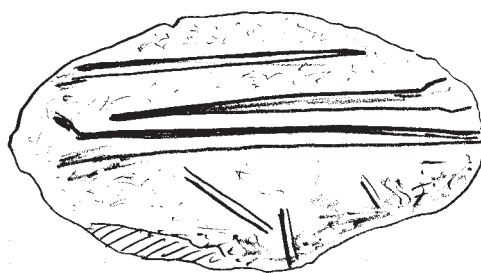
No. 530 F1099A

0 3cm



No. 531 F1076A

0 3cm

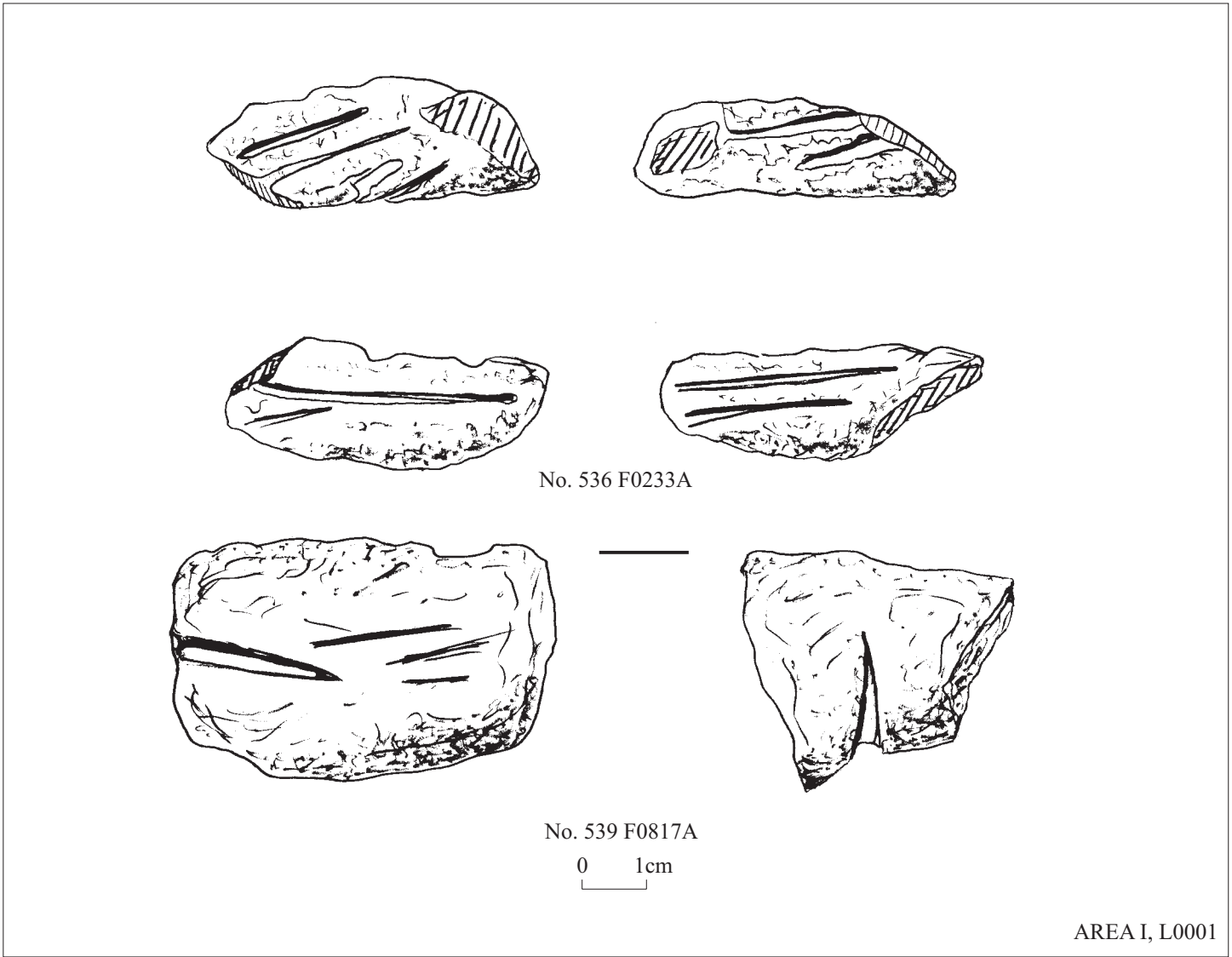


No. 534 F0028B

0 1cm

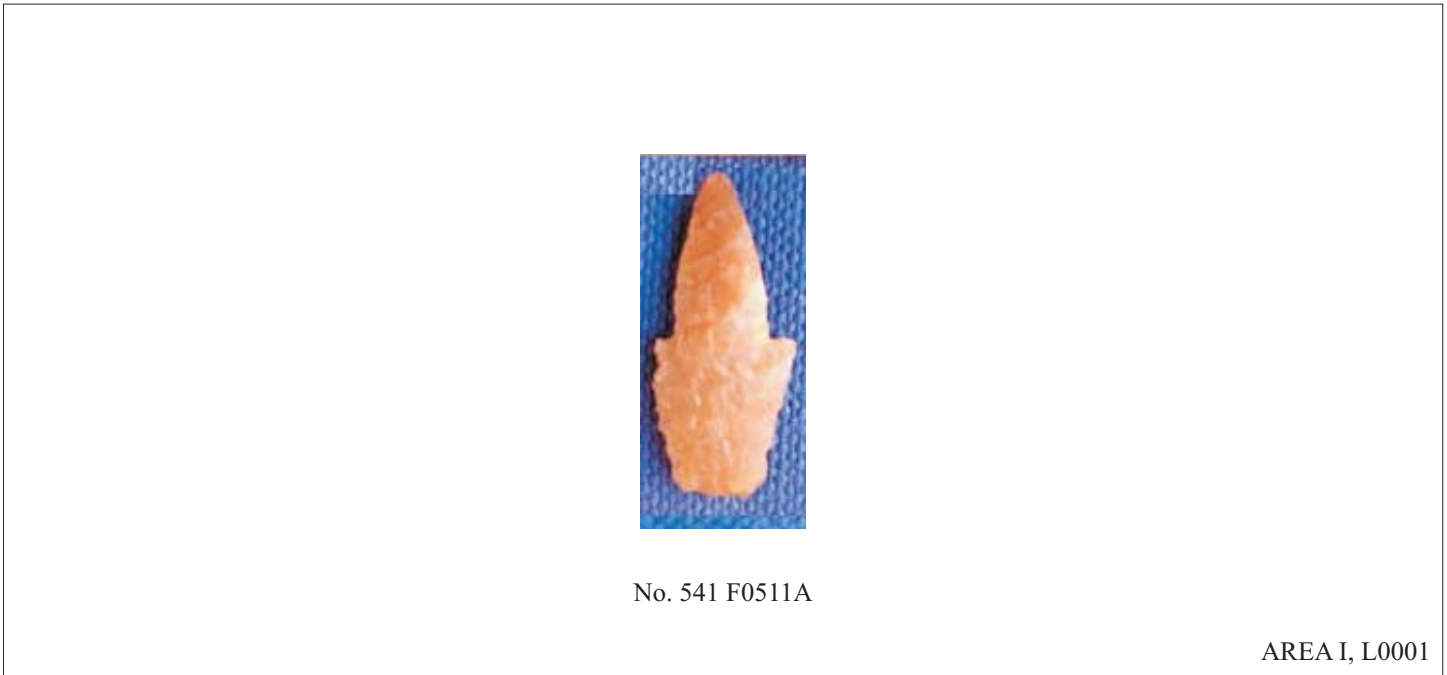
AREA I, L0001

Fig. 40:51

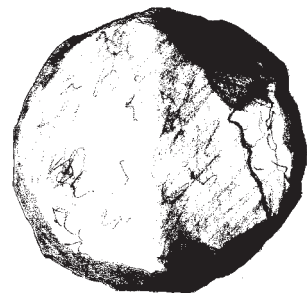
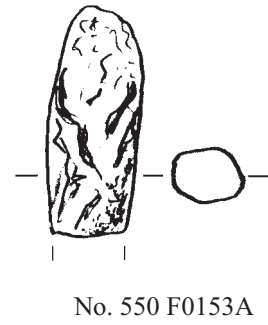
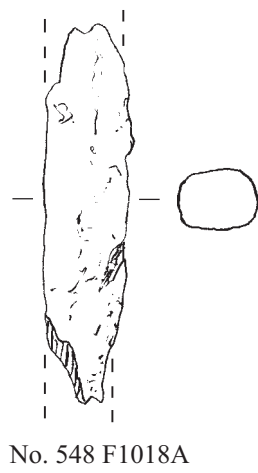
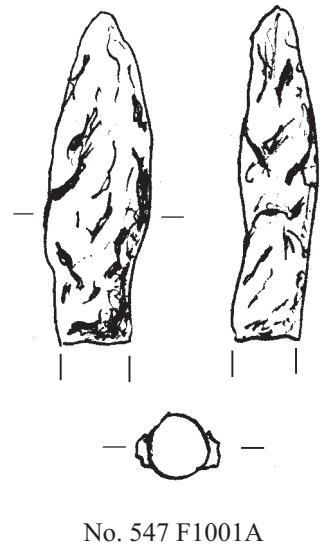
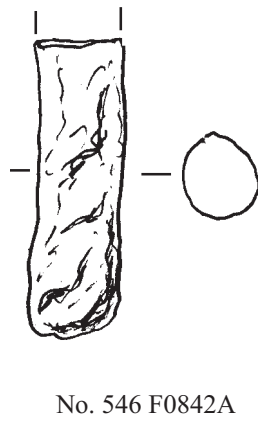
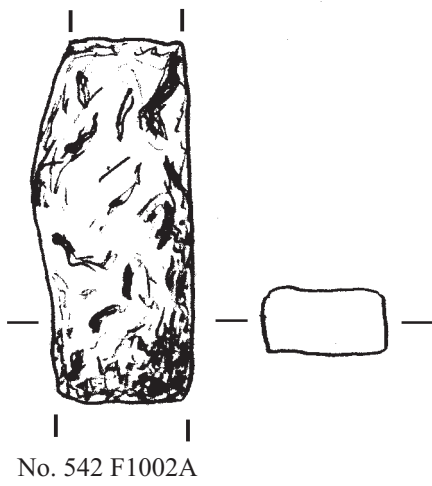


AREA I, L0001

Fig. 40:52



AREA I, L0001



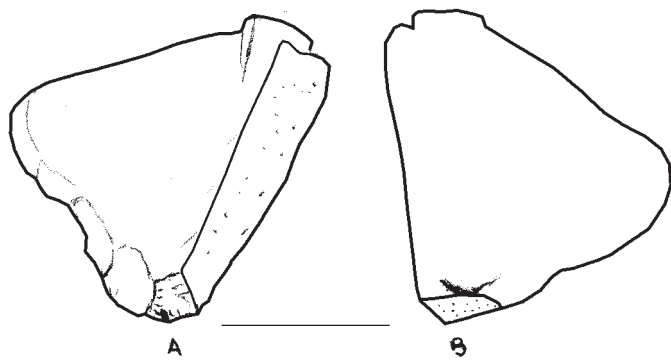
No. 554 F0518A



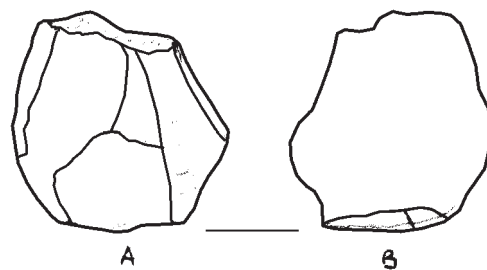
0 1cm

AREA I, L0001

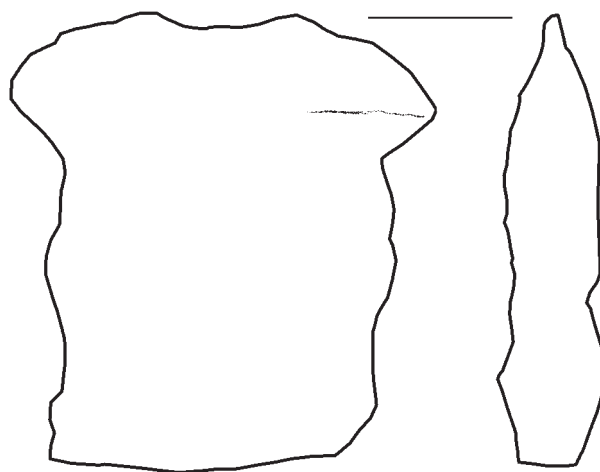
Fig. 40:53



No. 574 F0964A



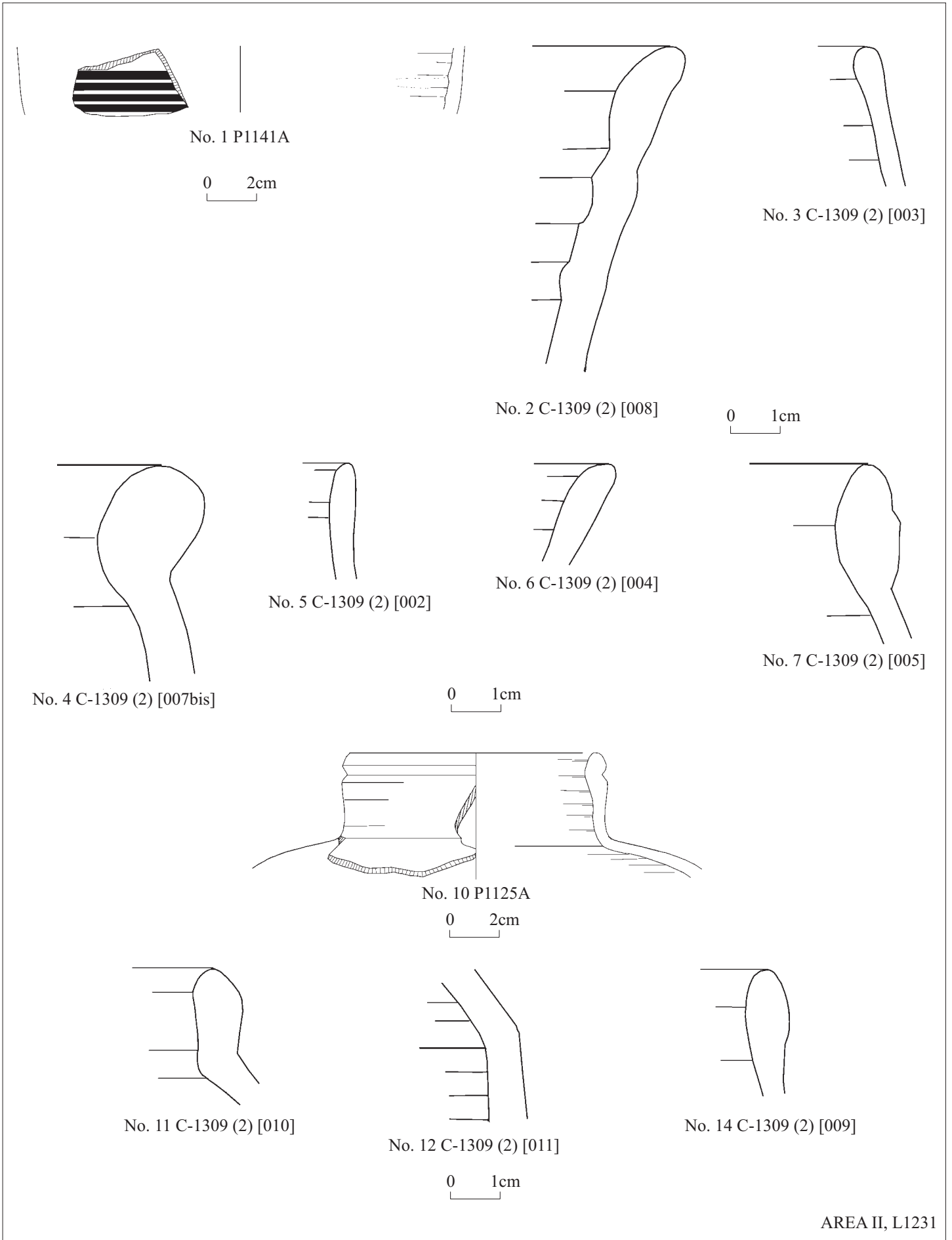
No. 575 F0965A



No. 576 F0979A

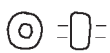
0 1cm

AREA I, L0001



AREA II, L1231

Fig. 1

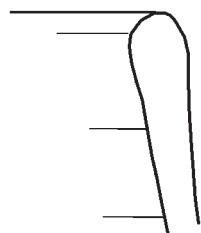


No. 1 F0667A

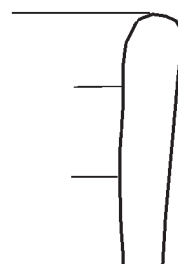


AREA II L1233

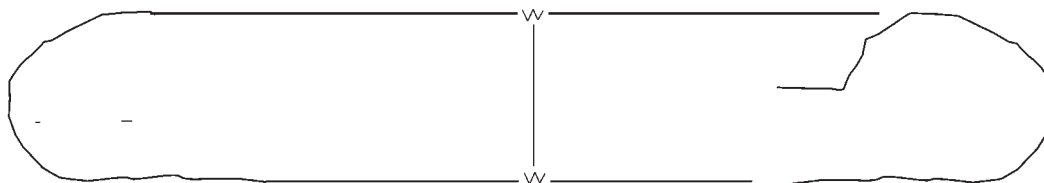
Fig. 2



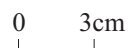
No. 1 C-1327 (2) [003]



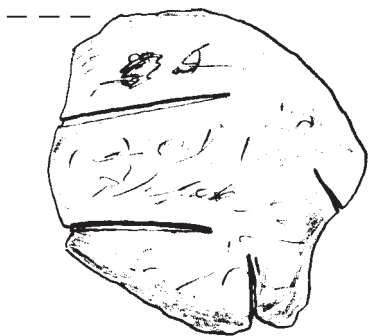
No. 2 C-1327 (2) [001]



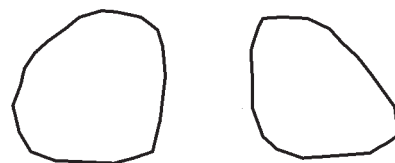
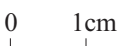
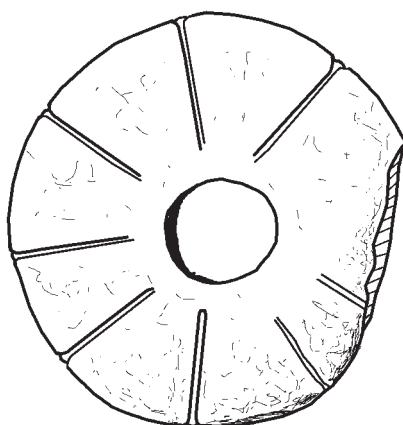
No. 3 P1115A



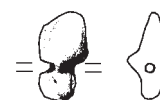
D: ca. 50 cm



No. 6 F0828A



No. 7 F0913A



No. 8 F0651A

AREA II, L1234

Fig. 3

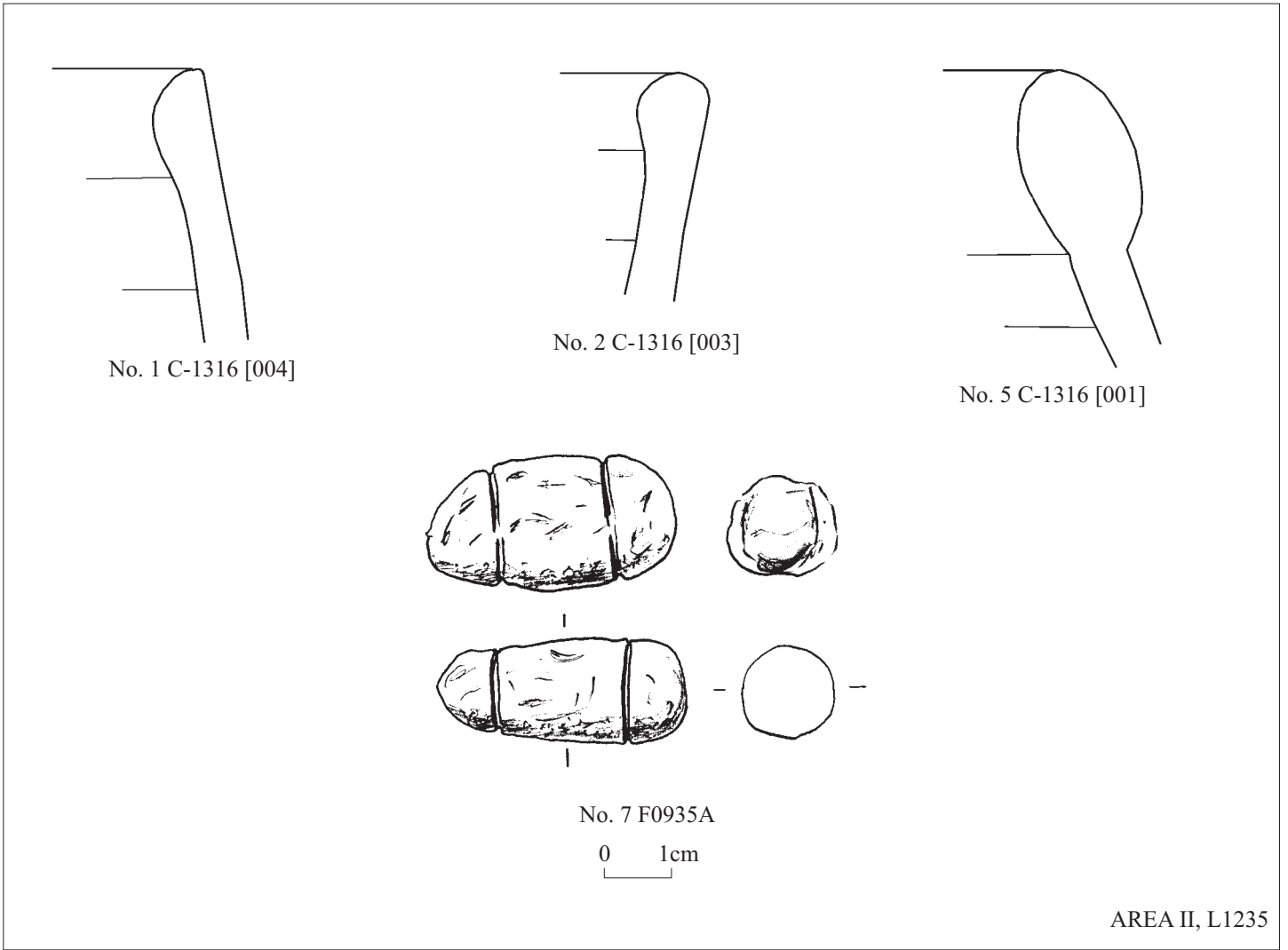


Fig. 4

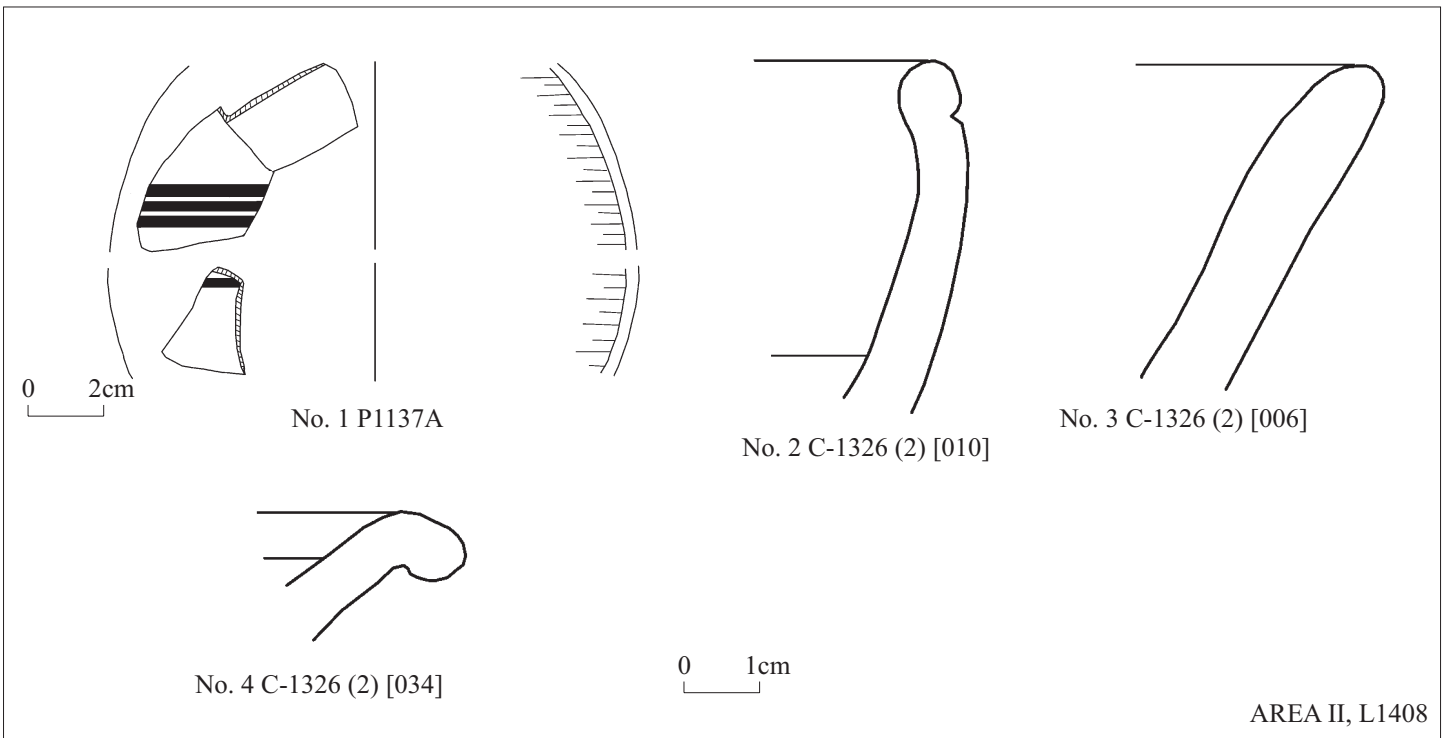
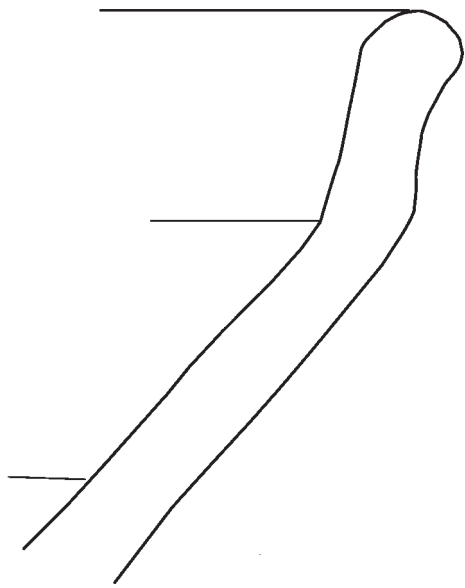
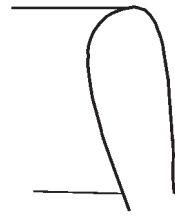


Fig. 5:1



No. 5 C-1326 (2) [005]



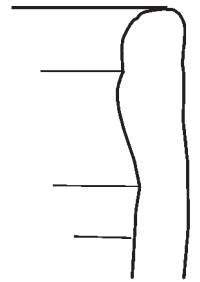
No. 6 C-1326 (2) [024]



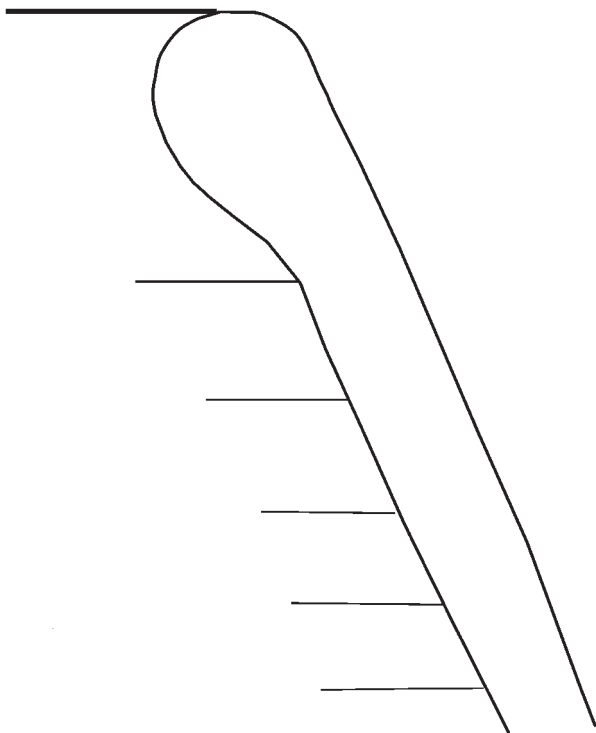
No. 7 C-1326 (2) [022]



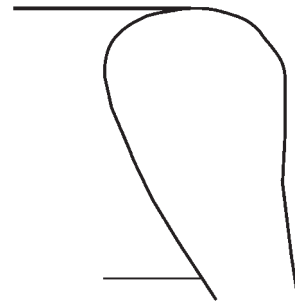
No. 8 C-1326 (2) [026bis]



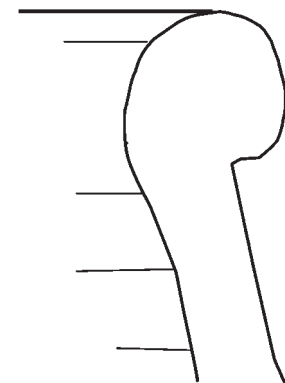
No. 9 C-1326 (2) [020]



No. 11 C-1326 (2) [008]



No. 13 C-1326 (2) [013]

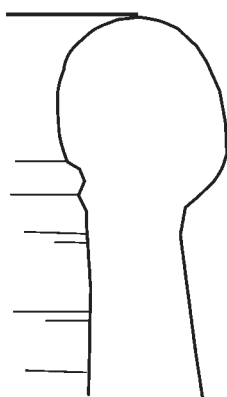


No. 14 C-1236 (2) [001]

0 1cm

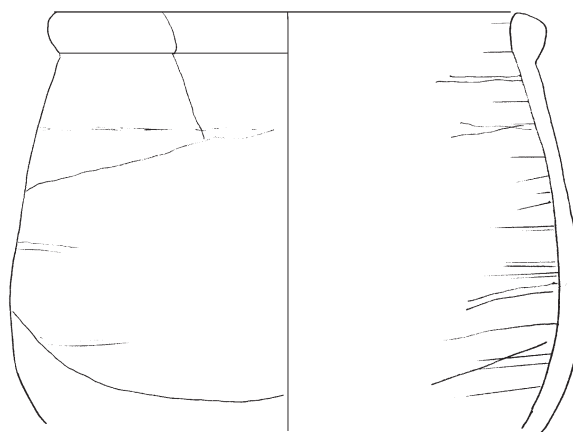
AREA II, L1408

Fig. 5:2



No. 15 C-1326 (2) [015]

0 1cm

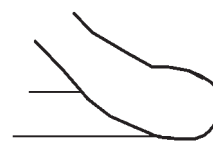


No. 16 P1172A

0 4cm



No. 17 C-1326 (2) [011]



No. 18 C-1326 (2) [012]

0 1cm

Fig. 5:3

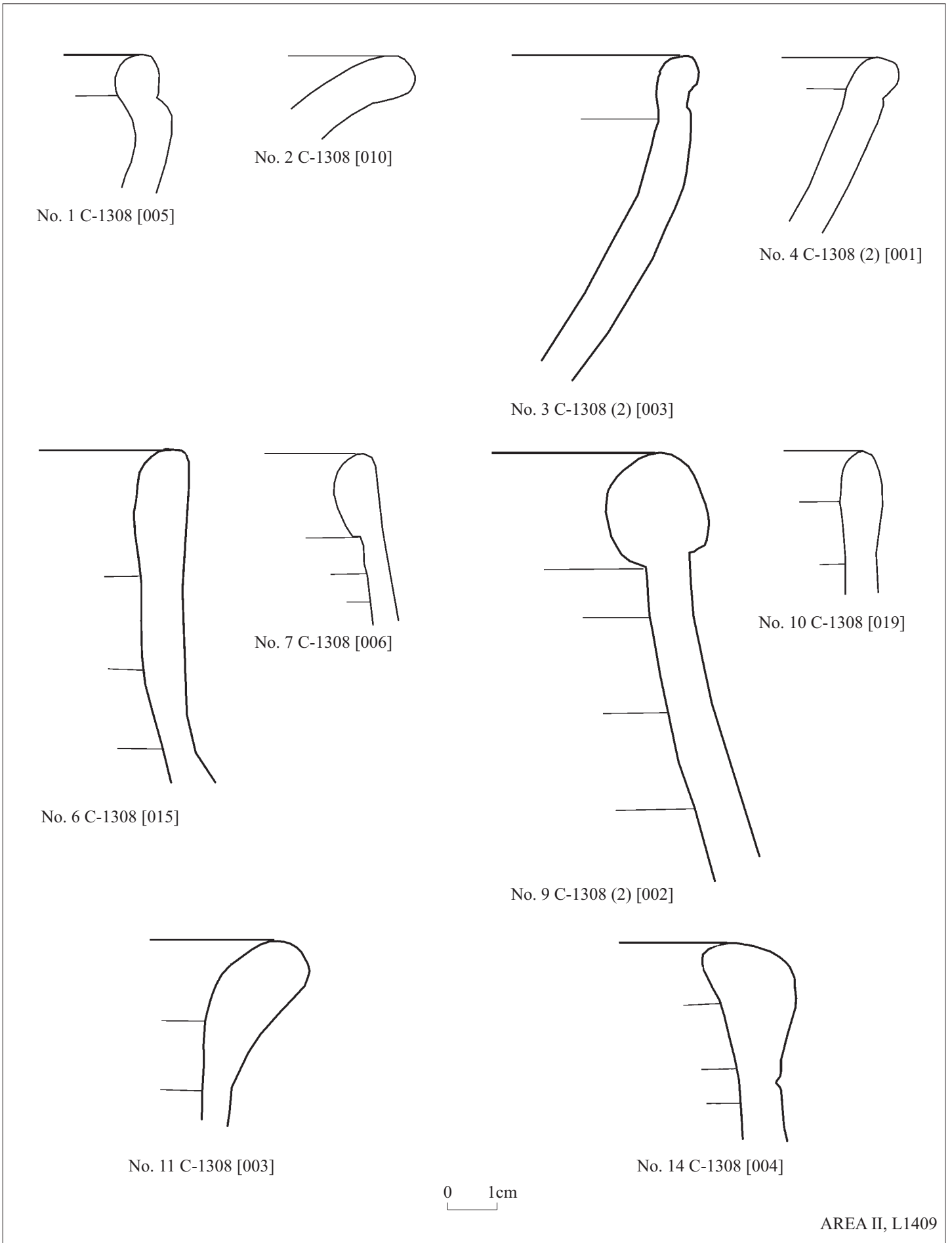


Fig. 6:1

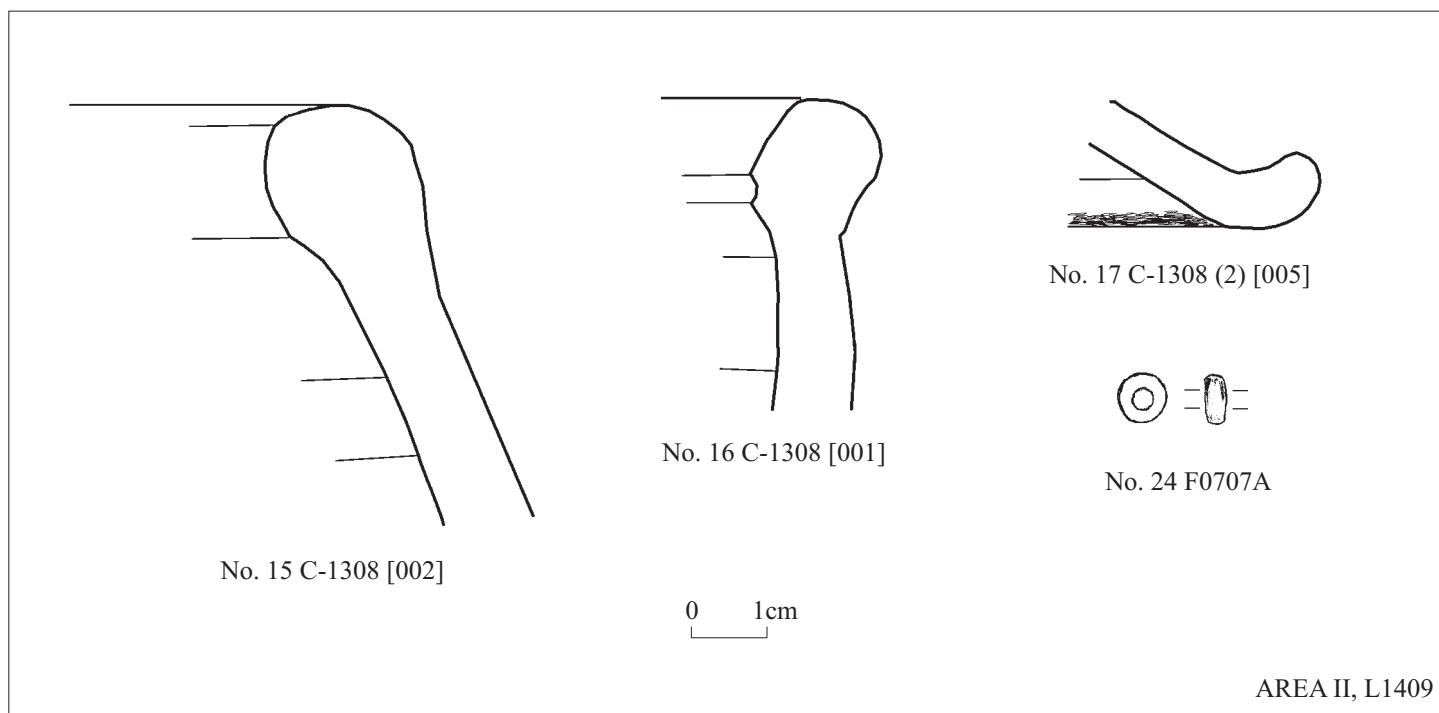


Fig. 6:2

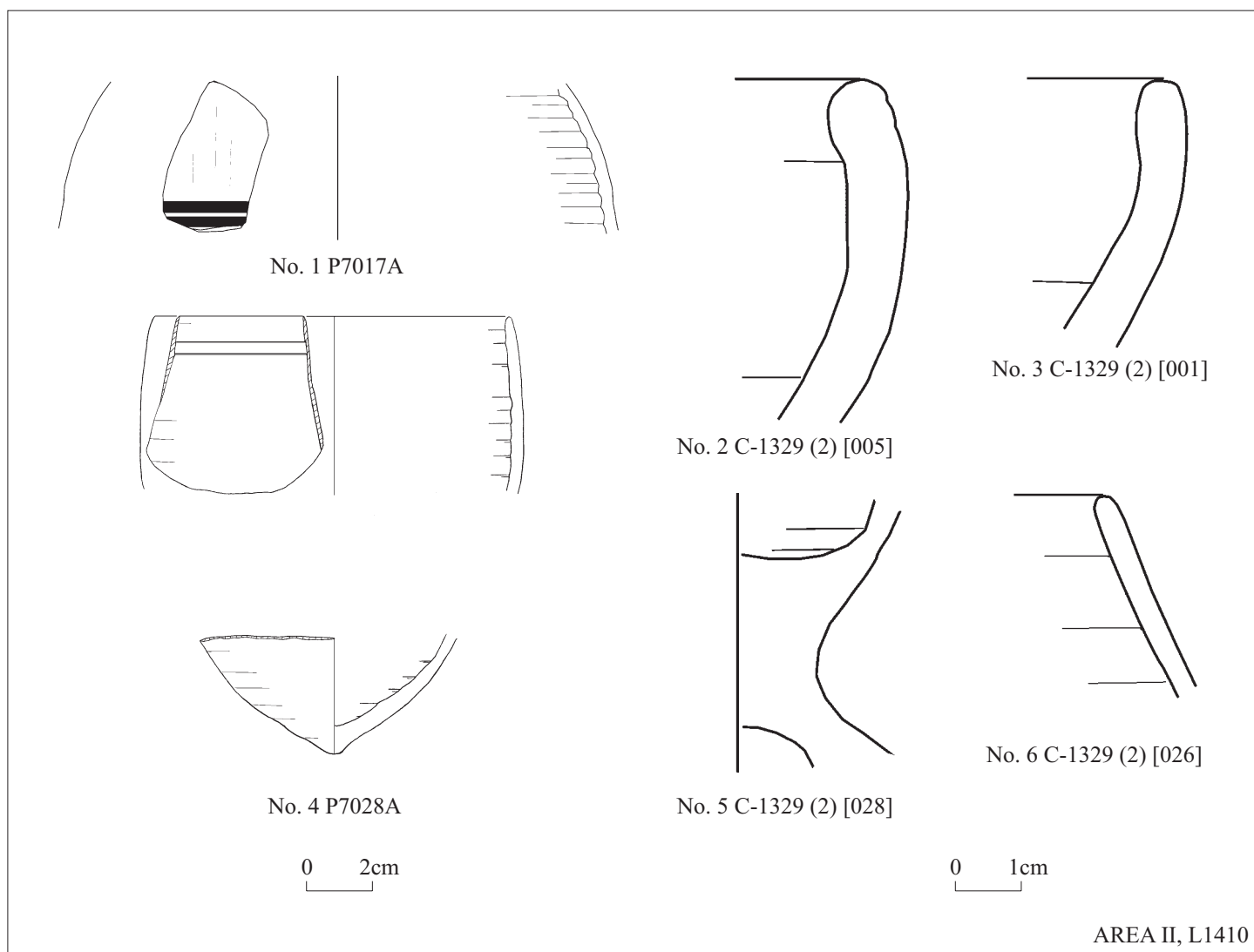
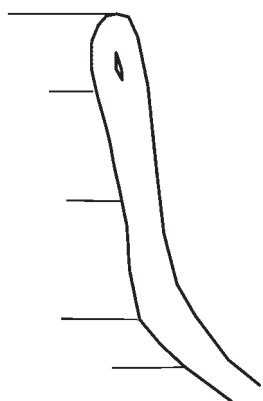


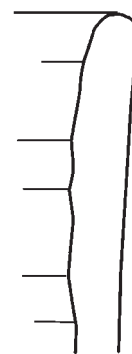
Fig. 7:1



No. 8 C-1329 (2) [006]

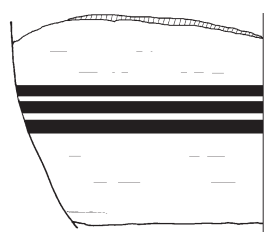


No. 9 C-1329 (2) [011]



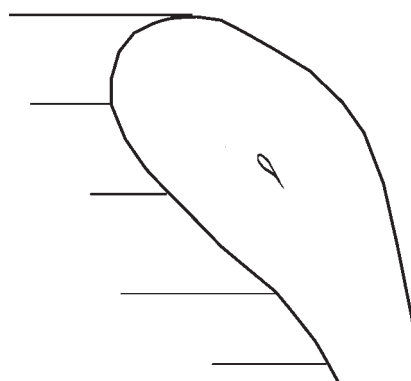
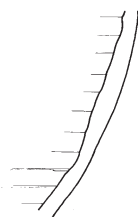
No. 10 C-1329 [004]

0 1cm

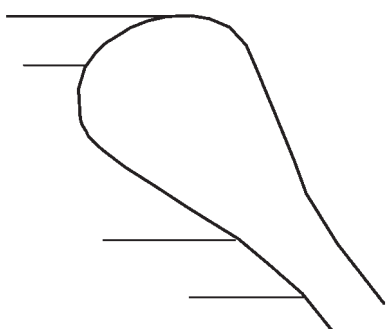


0 3cm

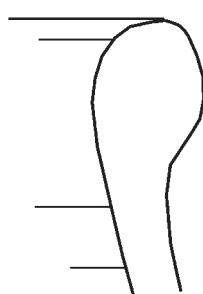
No. 11 P7038A



No. 13 C-1329 [002]

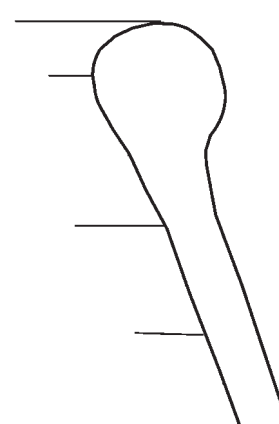


No. 14 C-1329 (2) [020]



No. 15 C-1329 [003]

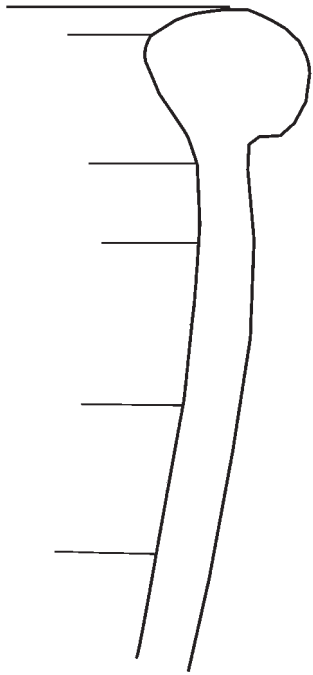
0 1cm



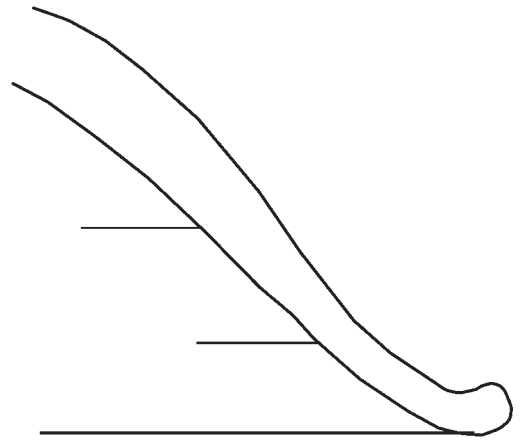
No. 16 C-1329 (2) [013]

AREA II, L1410

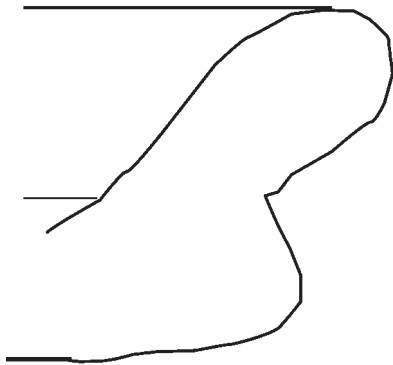
Fig. 7:2



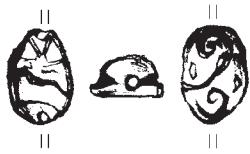
No. 17 C-1329 (2) [009]



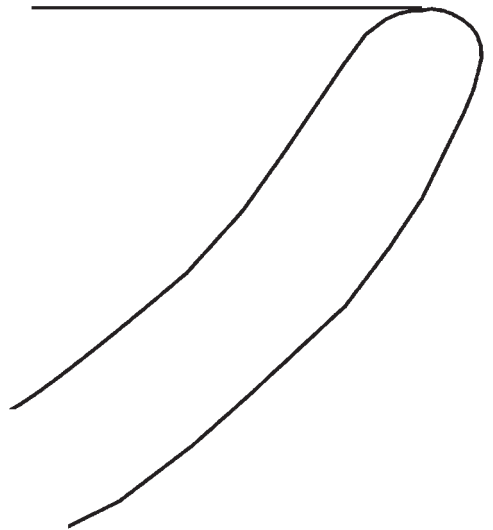
No. 20 C-1329 (2) [016]



No. 21 C-1329 [001]

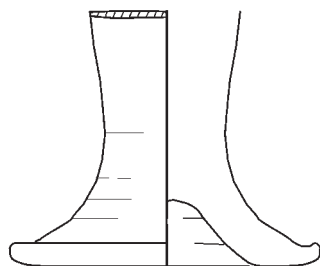


No. 27 F0640A



No. 29 F1083A

0 1cm

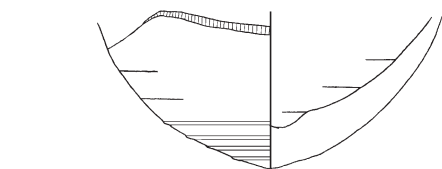


No. 1 P1124A

0 1cm

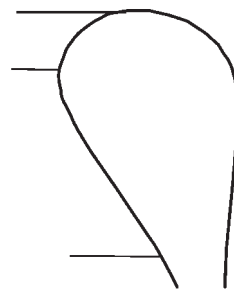
AREA II, L1413

Fig. 8



0 2cm

No. 1 P1235A



No. 2 C-1325 (2) [001]

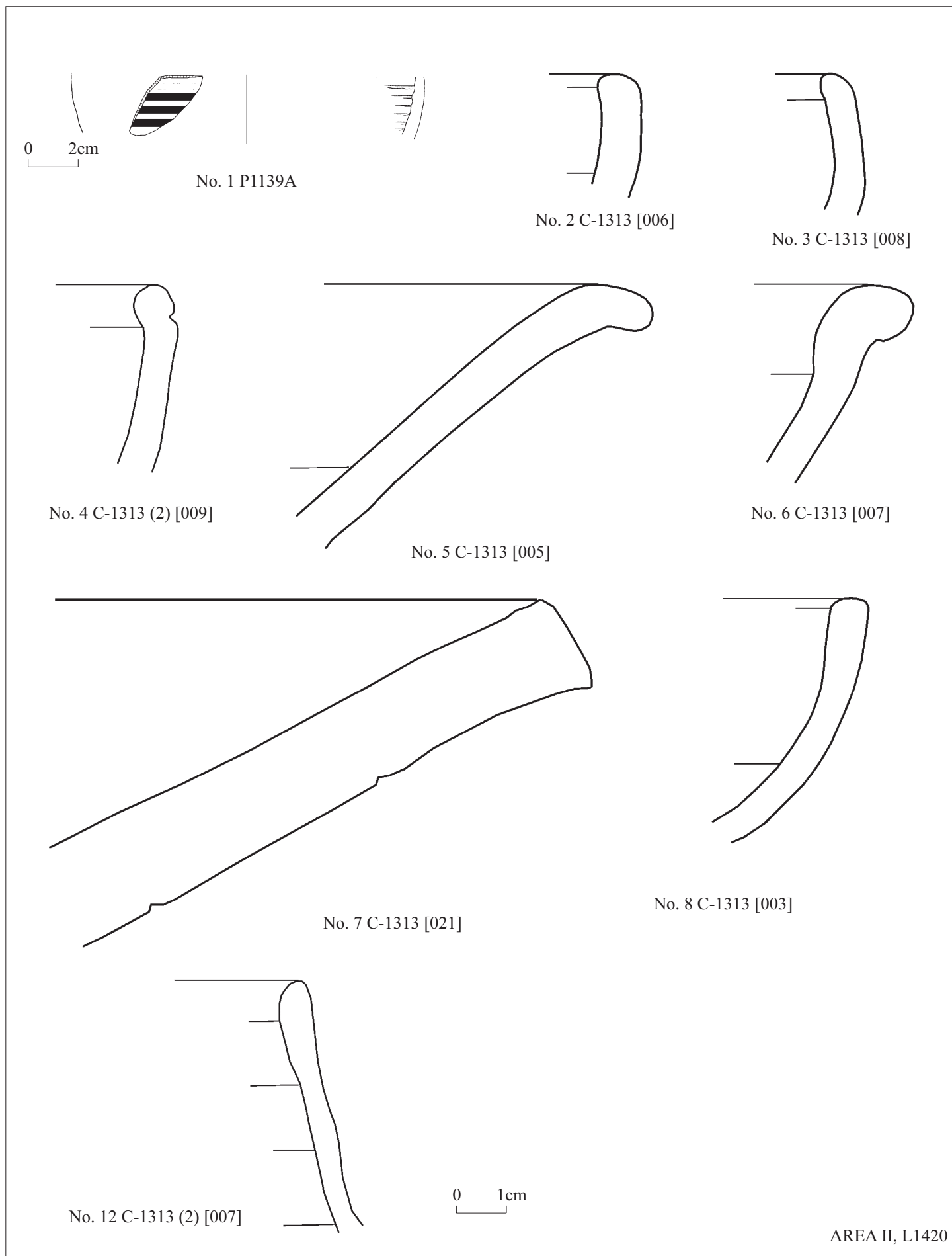


No. 3 F0677A

0 1cm

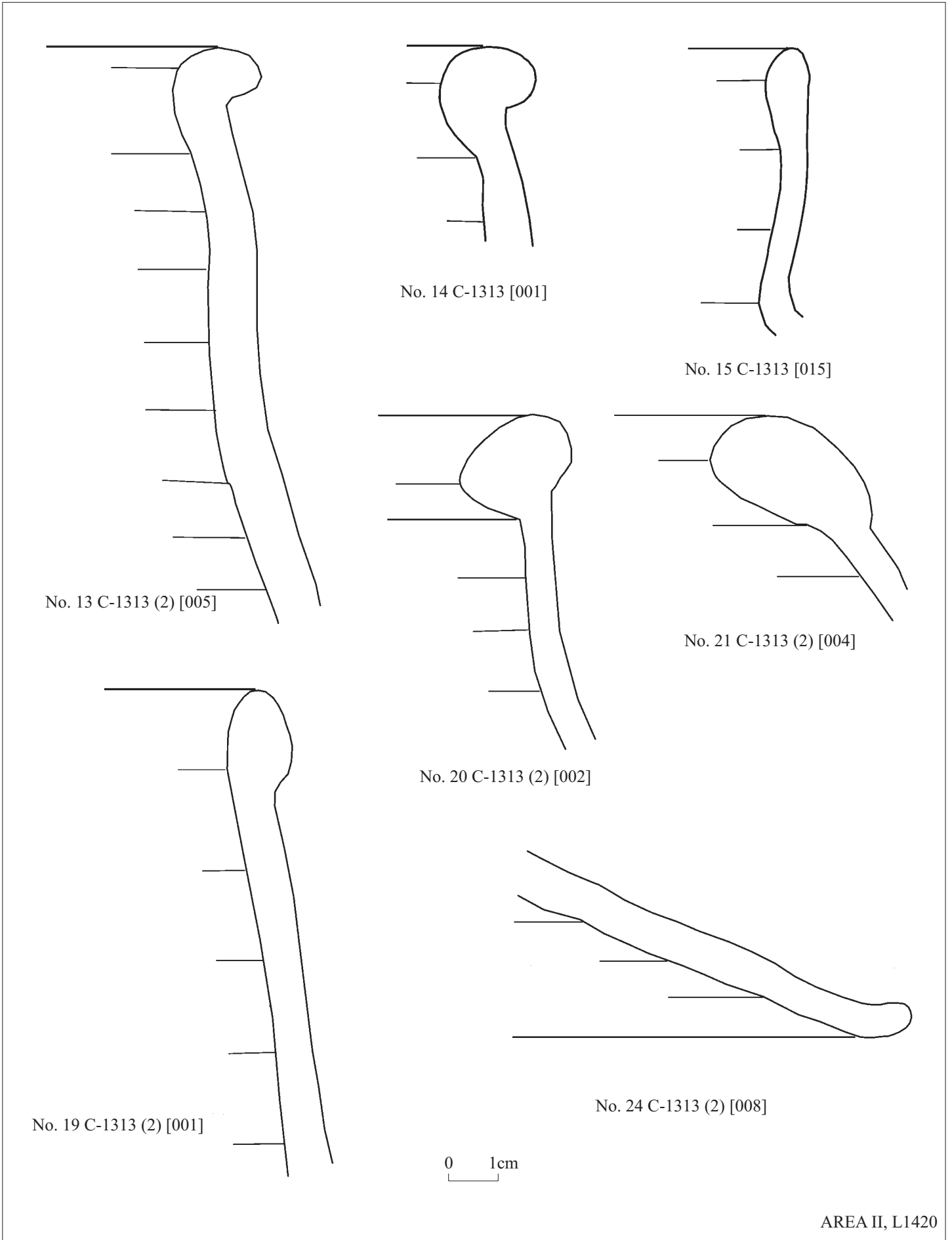
AREA II, L1419

Fig. 9



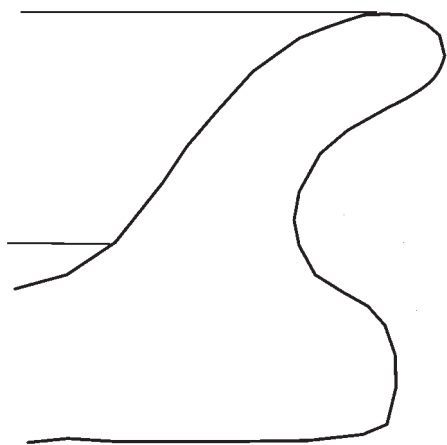
AREA II, L1420

Fig. 10:1

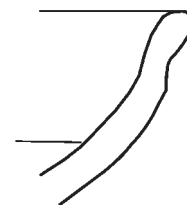


AREA II, L1420

Fig. 10:2

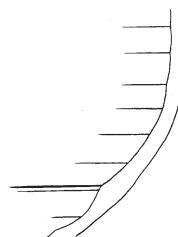
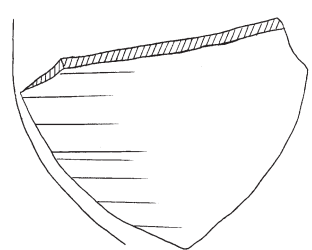


No. 25 C-1313 (2) [012]



No. 26 C-1313 [009]

0 1cm



No. 27 P1167A

0 2cm



No. 33 F0684



No. 34 F0637A



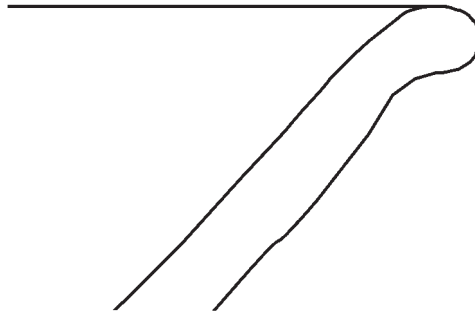
No. 35 F0639A

0 1cm

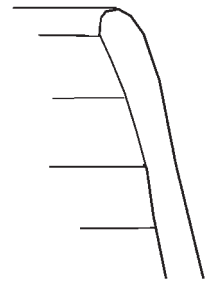
Fig. 10:3



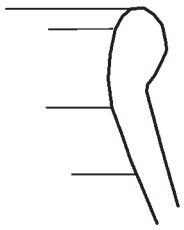
No. 1 C-1075 (2) [001]



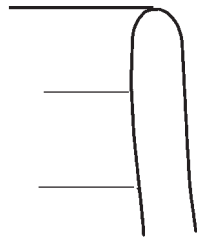
No. 2 C-1305 bis (2) [003]



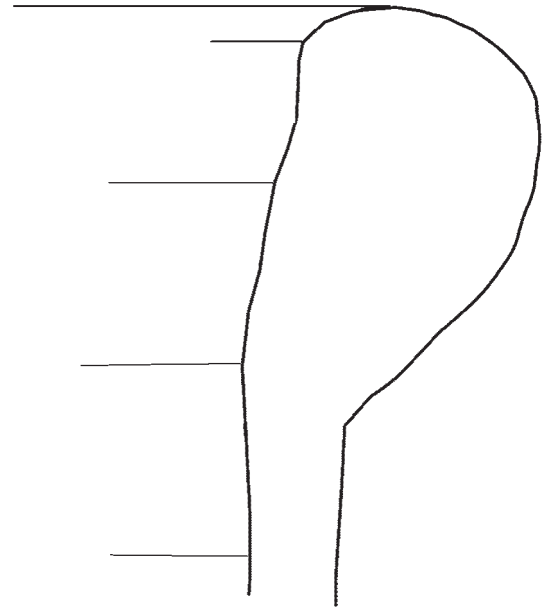
No. 4 C-1303 (2) [002]



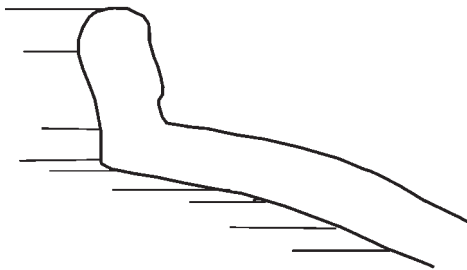
No. 5 C-1305 bis (2) [006]



No. 6 C-1305 bis (2) [002]

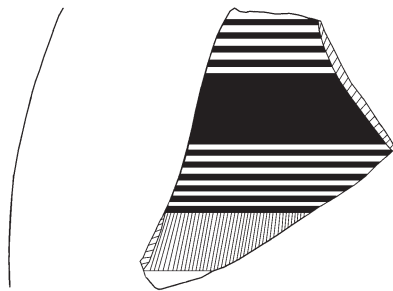


No. 13 C-1043 [001]



No. 17 C-1043 [003]

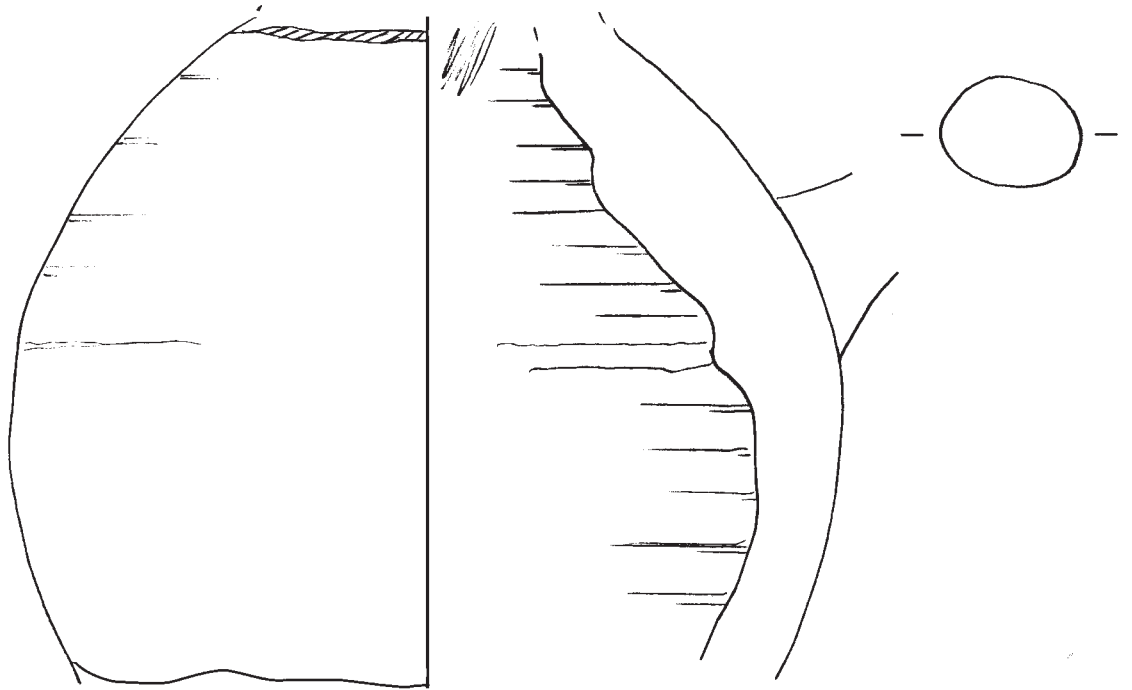
0 1cm



No. 19 P1189A

0 2cm

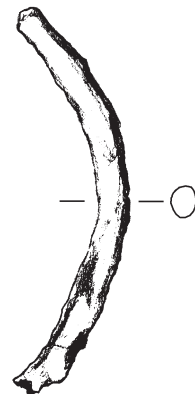




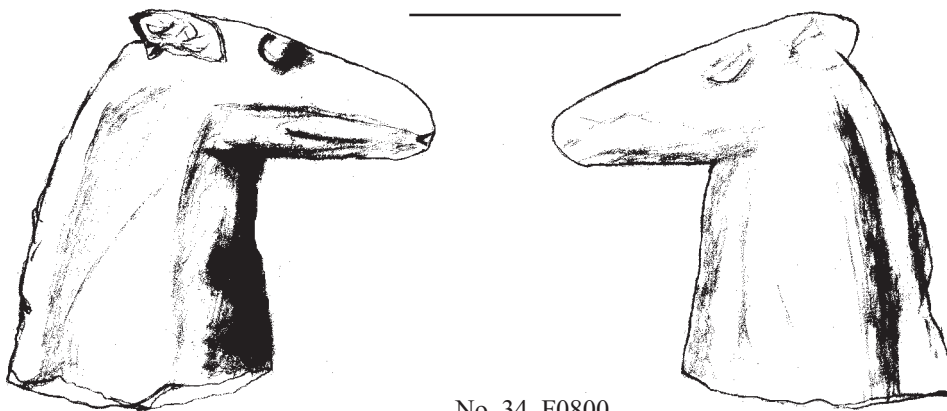
No. 20 P7043A



No. 29 P2032A



No. 35 F0696A

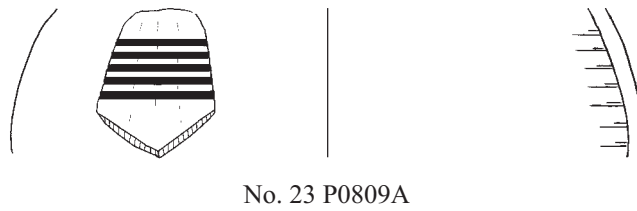
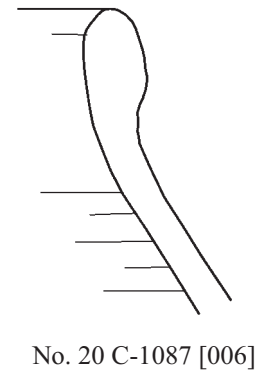
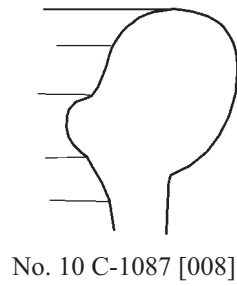
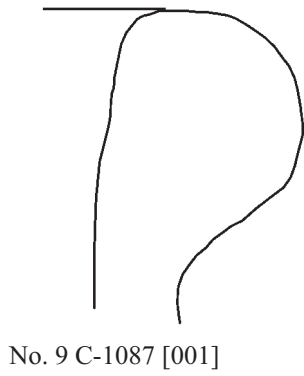
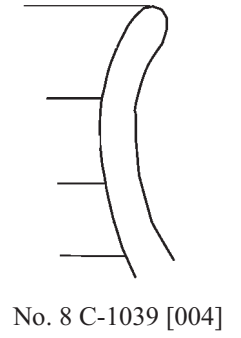
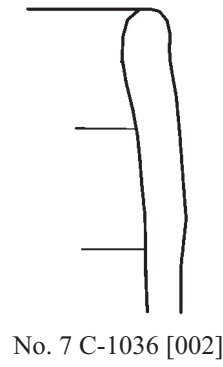
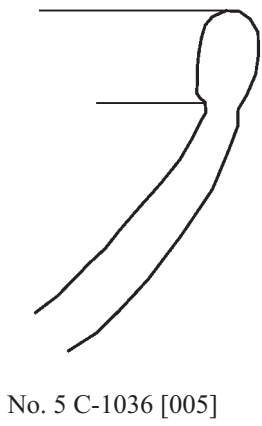
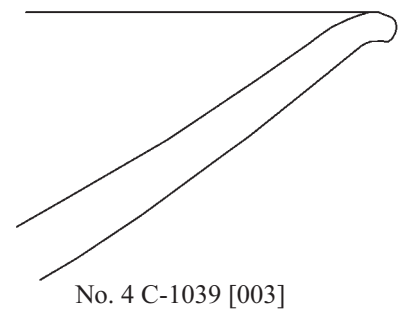
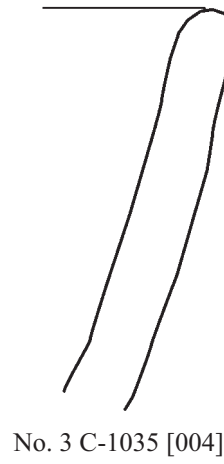
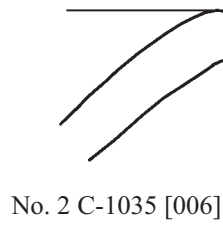
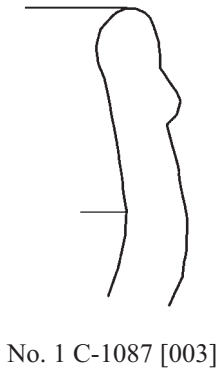


No. 34 F0800

0 1cm

AREA II, L1102

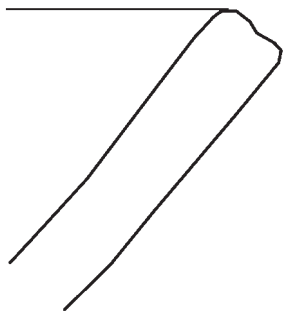
Fig. 11:2



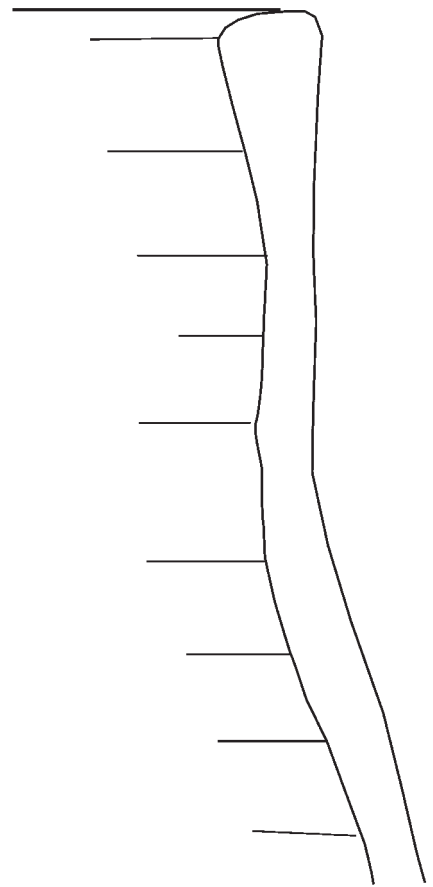
0 1cm

AREA II, L1104

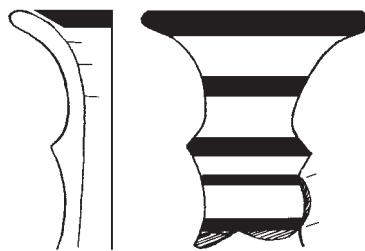
Fig. 12



No. 1 C-1076 [001]

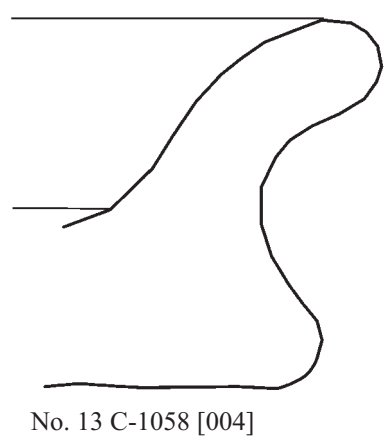
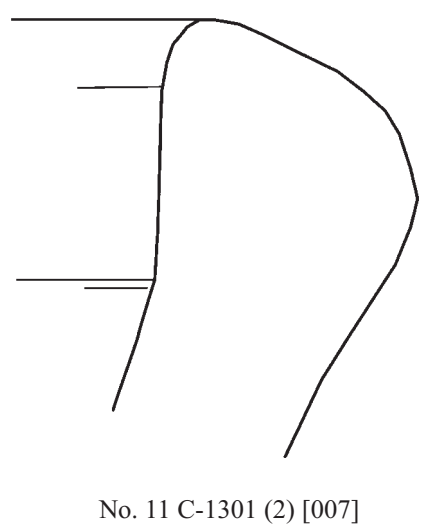
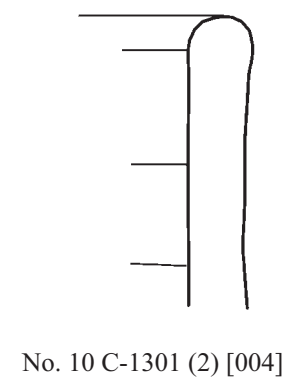
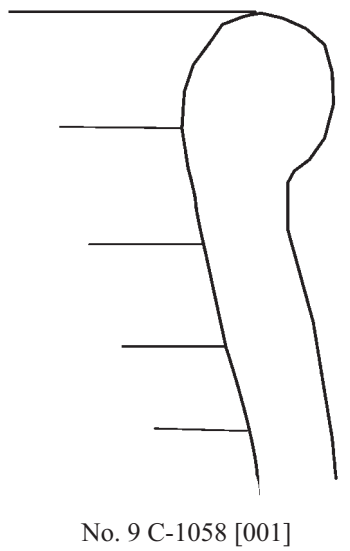
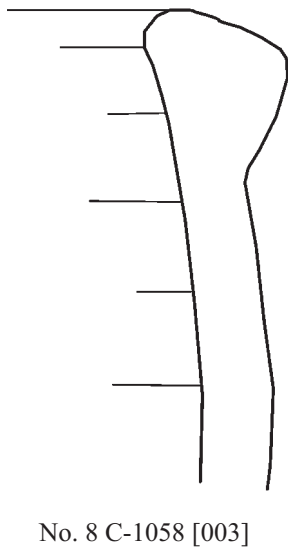
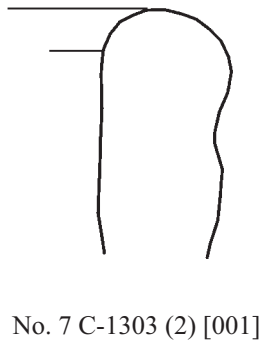
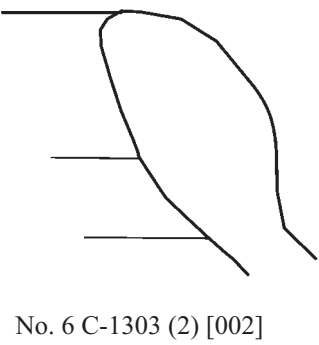
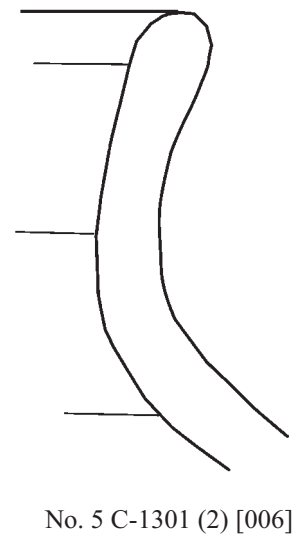
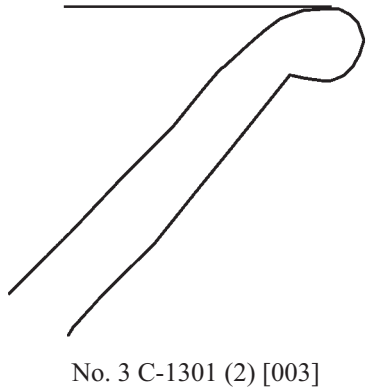
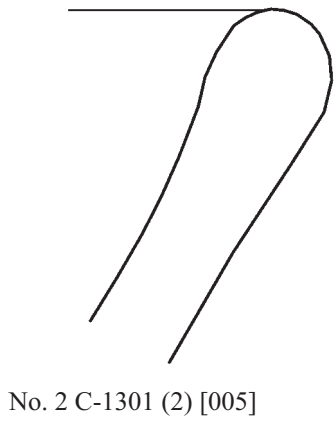
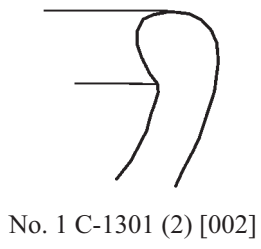


No. 2 C-1071 [001]



No. 6 P2007A

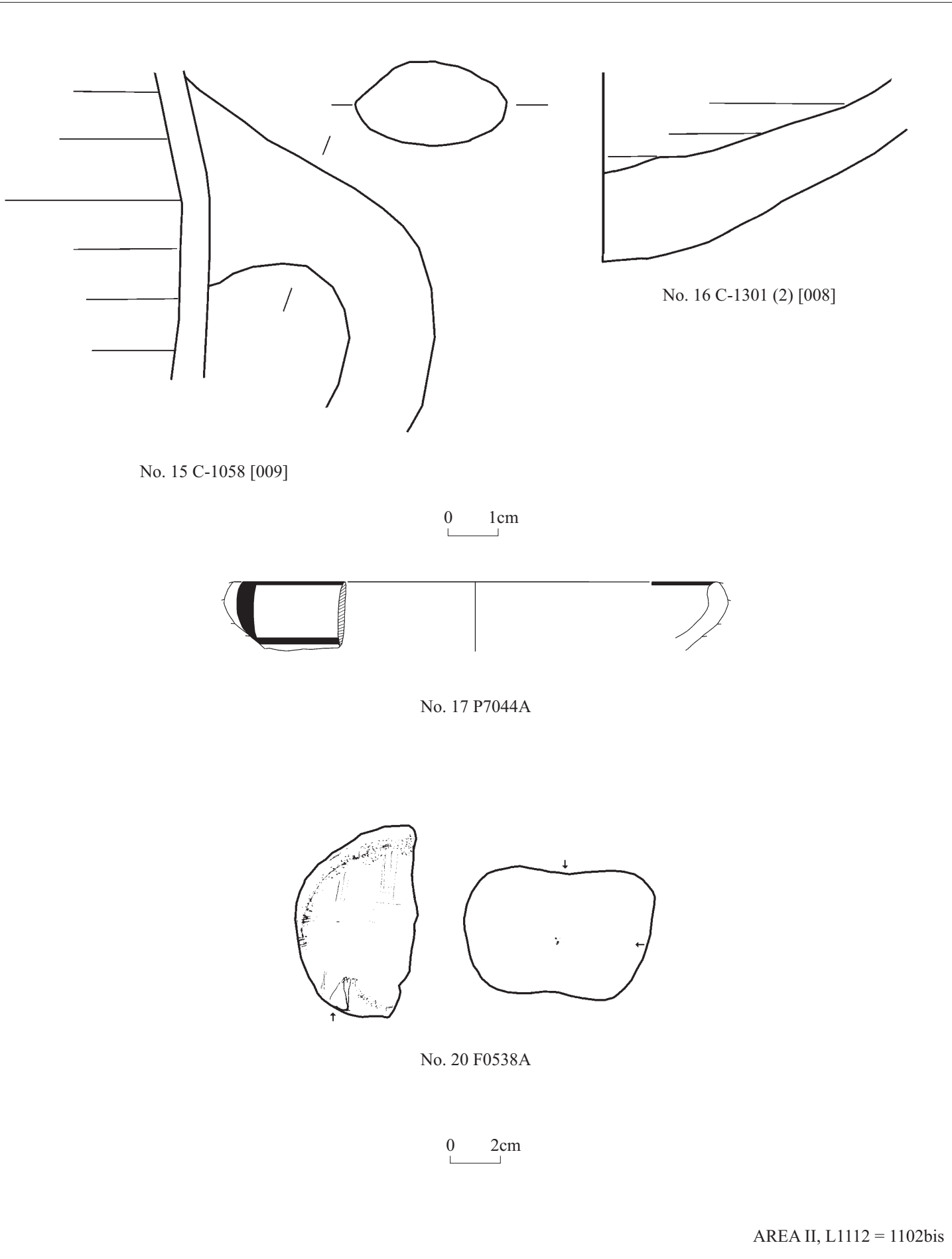
0 1cm



0 1cm

AREA II, L1112 = 1102bis

Fig. 14:1



No. 15 C-1058 [009]

No. 16 C-1301 (2) [008]

0 1cm

No. 17 P7044A

No. 20 F0538A

0 2cm

AREA II, L1112 = 1102bis

Fig. 14:2

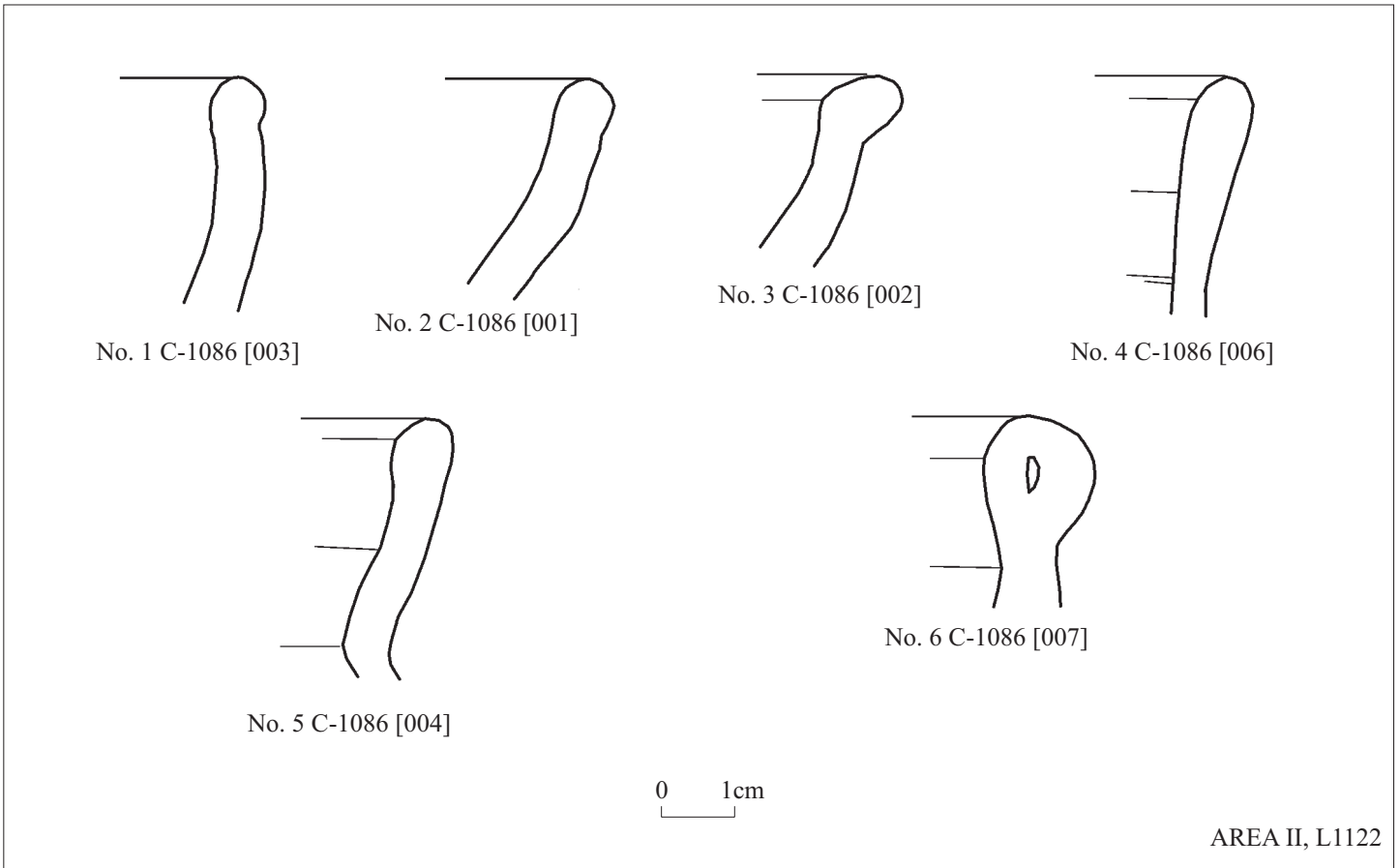


Fig. 15

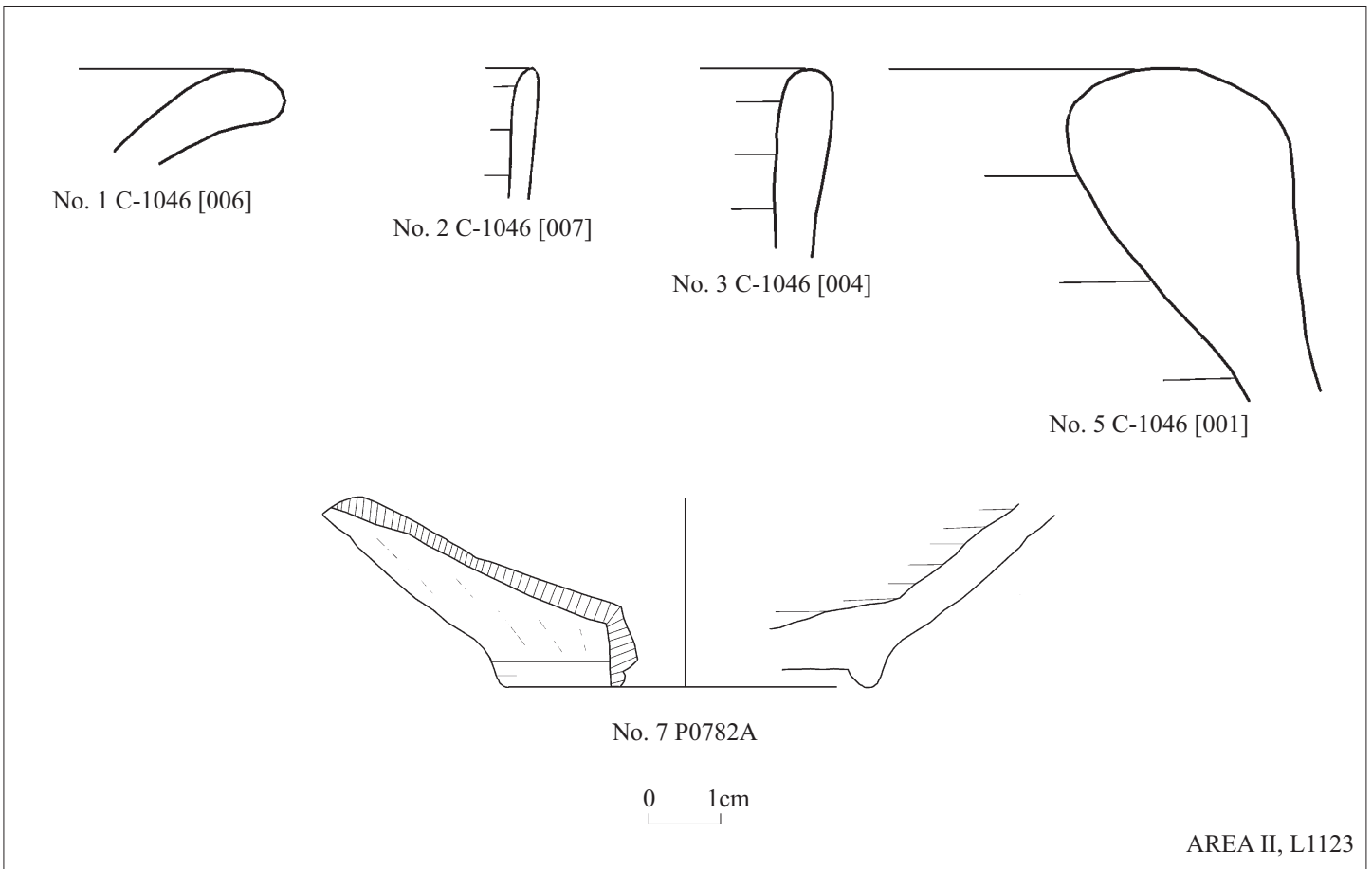
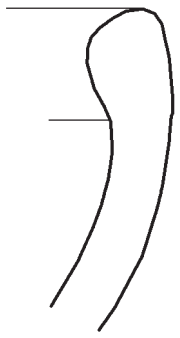
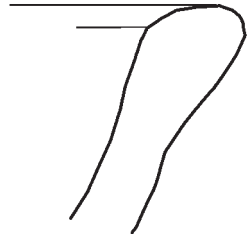


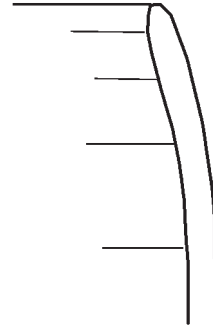
Fig. 16



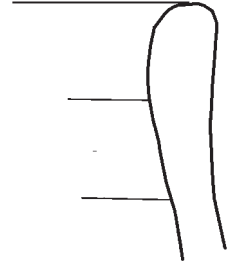
No. 1 C-1304 (2) [007]



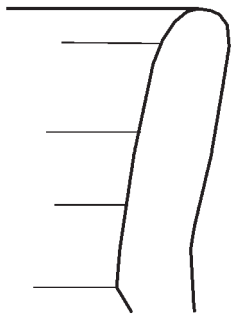
No. 2 C-1304 (2) [008]



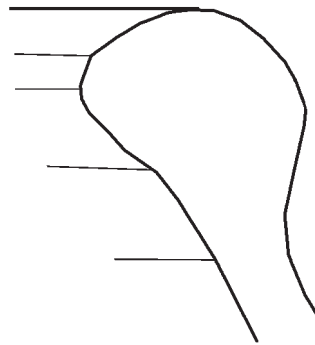
No. 3 C-1304 (2) [001]



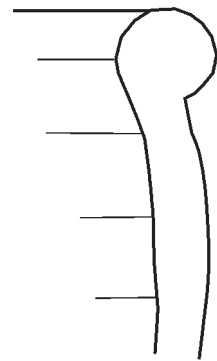
No. 4 C-1304 (2) [004]



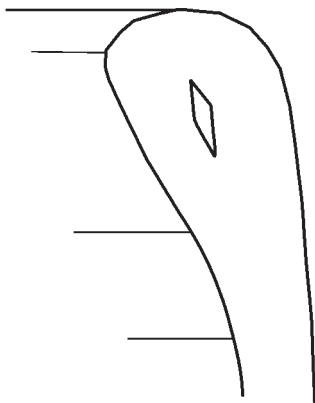
No. 5 C-1304 (2) [002]



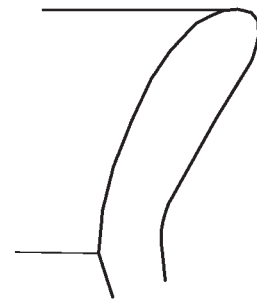
No. 10 C-1304 (2) [013]



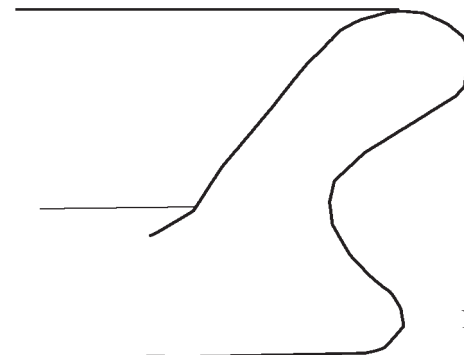
No. 11 C-1304 (2) [006]



No. 12 C-1304 (2) [010]



No. 13 C-1304 (2) [009]

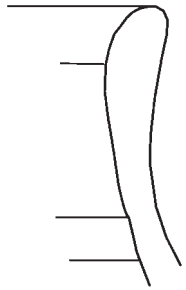


No. 15 C-9079 [001]

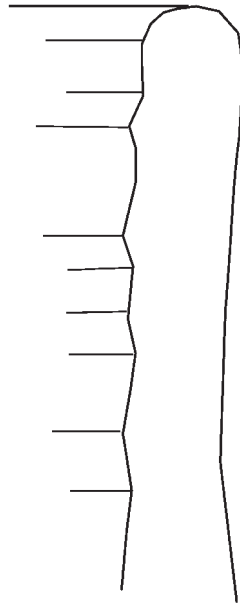
0 1cm

AREA II, L1124

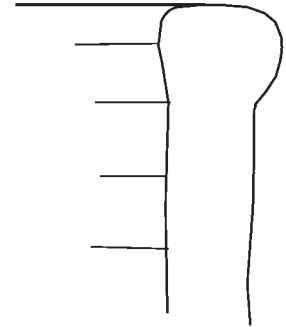
Fig. 17



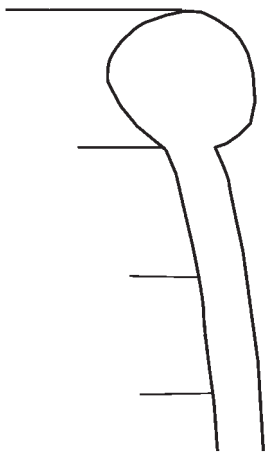
No. 1 C-1085 (2) [001]



No. 2 C-1338 (2) [005]



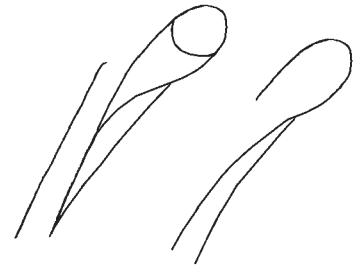
No. 3 C-1338 (2) [006]



No. 5 C-1338 (2) [002]

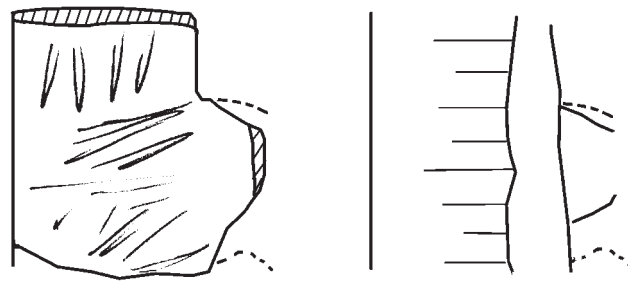


No. 6 P2037A



0 1cm

Fig. 18

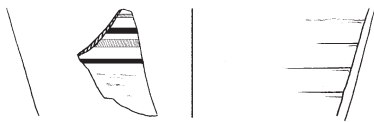


No. 1 P7057A

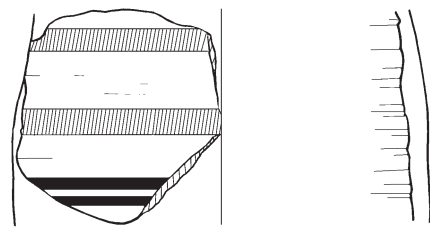


No. 2 P7010A

0 1cm

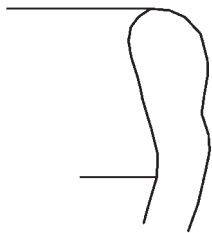


No. 3 P1123A

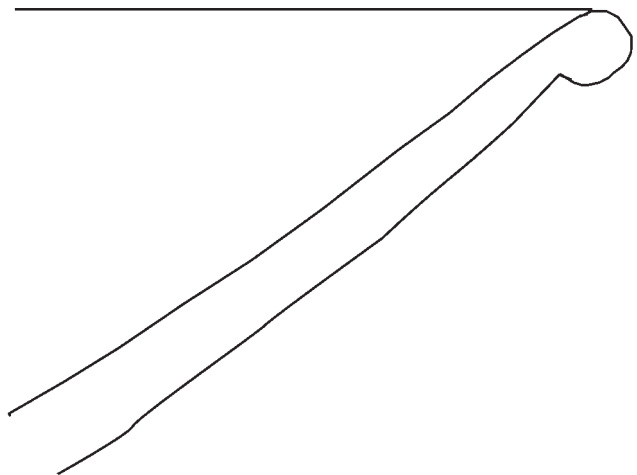


No. 4 P1127A

0 2cm



No. 5 C-1031 (2) [013]

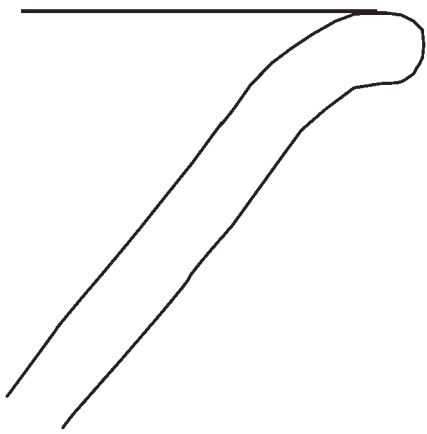


No. 6 C-1031 (2) [003]

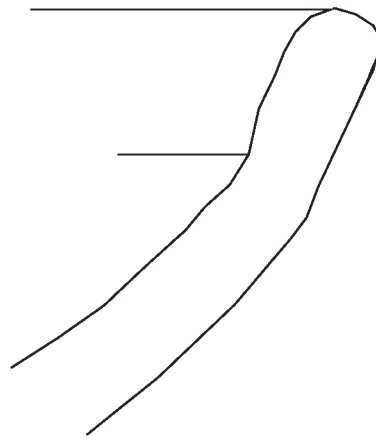
0 1cm

AREA II, L1126

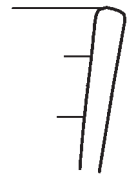
Fig. 19:1



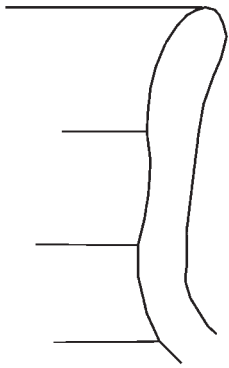
No. 7 C-1300 [033]



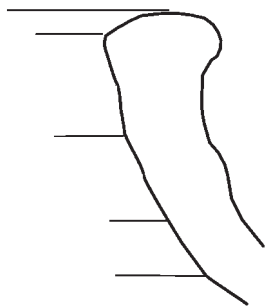
No. 8 C-1031 (2) [005]



No. 9 C-1300 [027]



No. 10 C-1031 (2) [009]



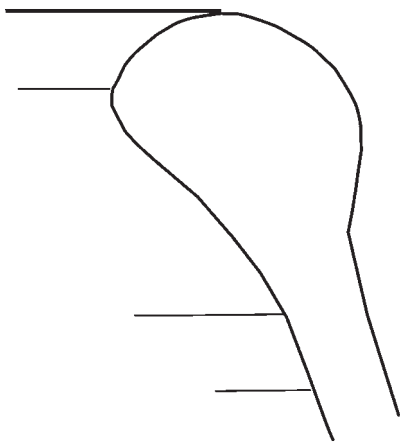
No. 11 C-1300 [029]



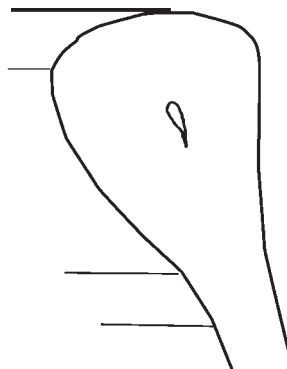
No. 12 C-1300 [046]



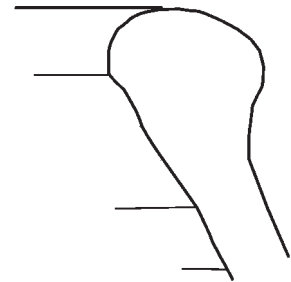
No. 13 C-1300 [015]



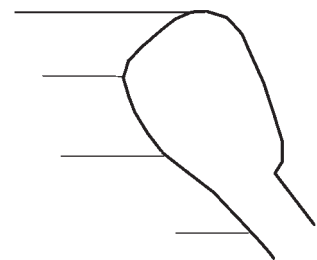
No. 19 C-1300 [039]



No. 20 C-1300 [043]



No. 21 C-1300 [045]

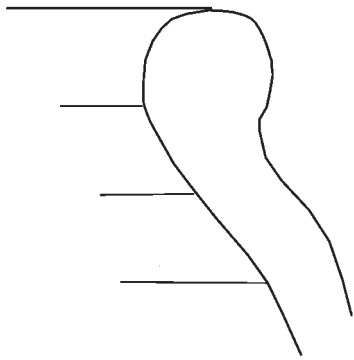


No. 22 C-1300 [047]

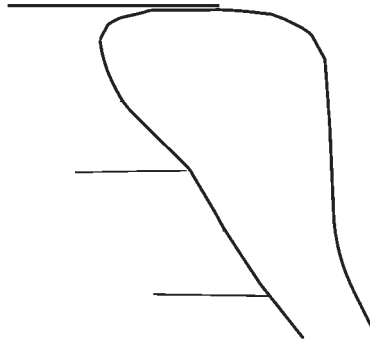
0 1cm

AREA II, L1126

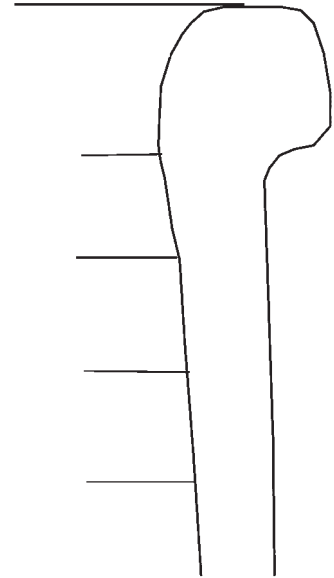
Fig. 19:2



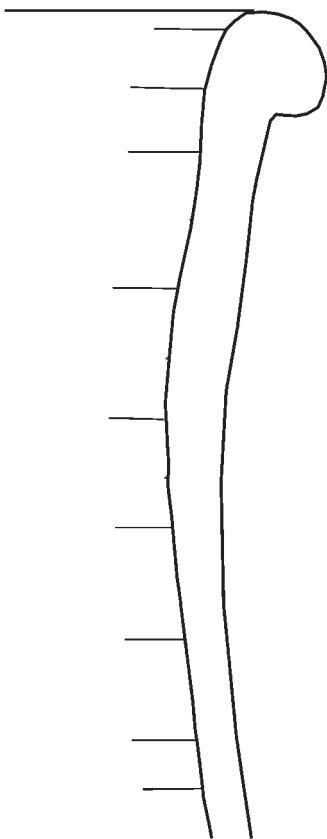
No. 23 C-1031 (2) [006]



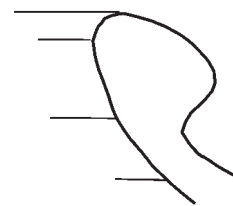
No. 24 C-1300 [042]



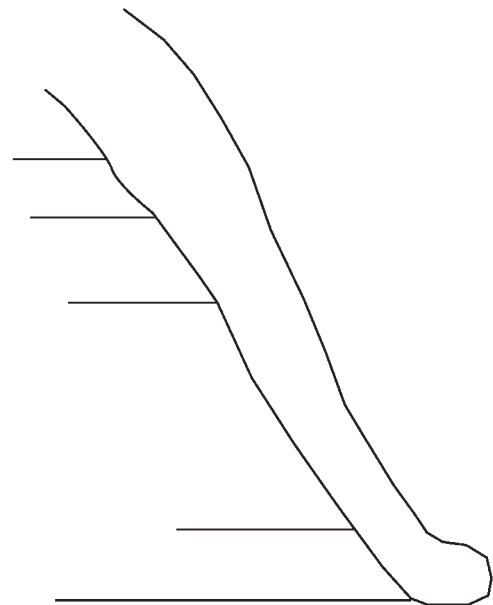
No. 25 C-1031 (2) [002]



No. 26 C-1300 [026]



No. 28 C-1300 [030]

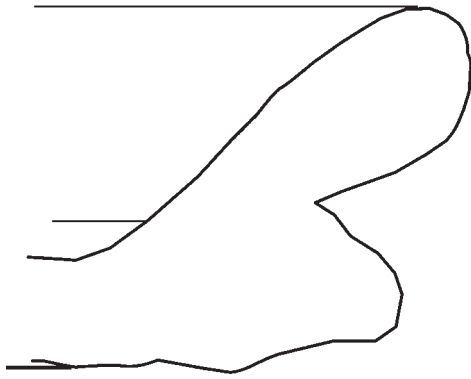


No. 29 C-1300 (3) [006]

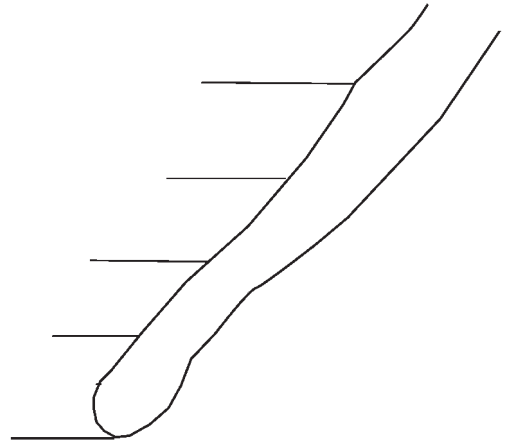
0 1cm

AREA II, L1126

Fig. 19:3

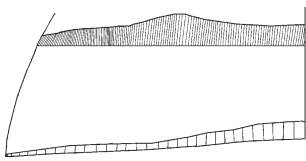


No. 30 C-1300 [048]



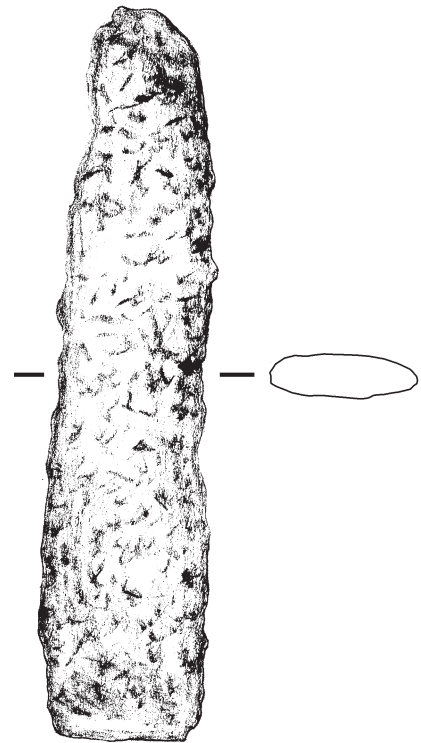
No. 31 C-1300 [050]

0 1cm



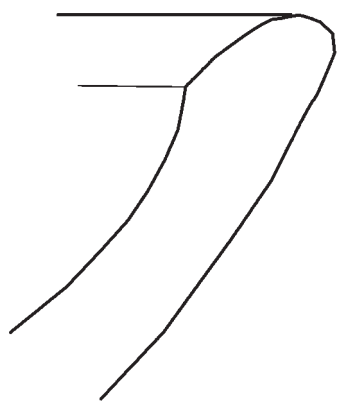
No. 36 P7009A

0 2cm

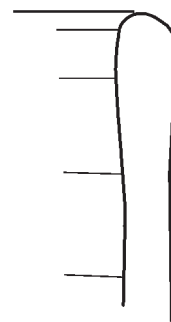


No. 54 F0446A

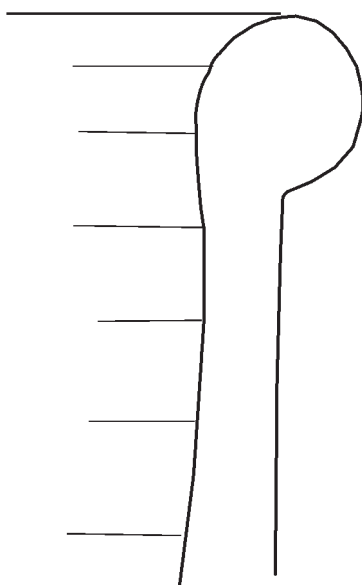
0 1cm



No. 1 C-1092 [002]



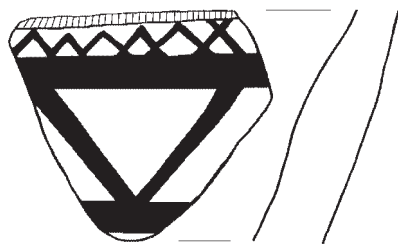
No. 2 C-1092 [001]



No. 3 C-1092 [003]

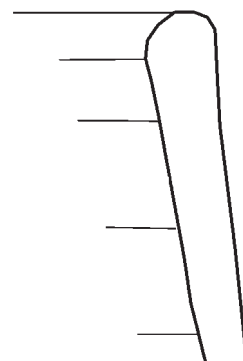
0 1cm

Fig. 20



No. 1 P1171A

0 2cm

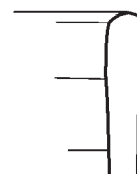


No. 4 C-1339 (2) [003]

0 1cm

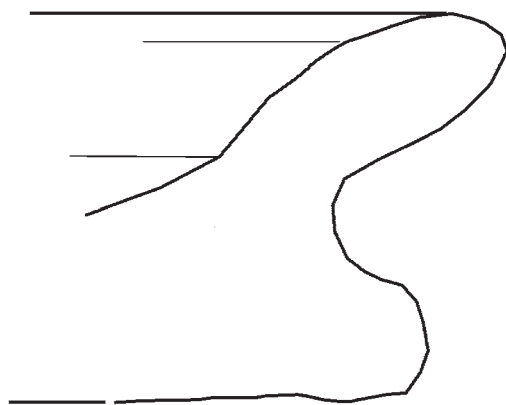


No. 5 C-1339 (2) [007]



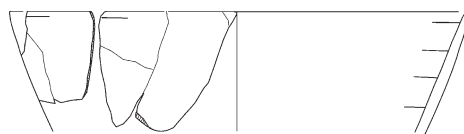
No. 6 C-1339 (2) [005]

0 1cm



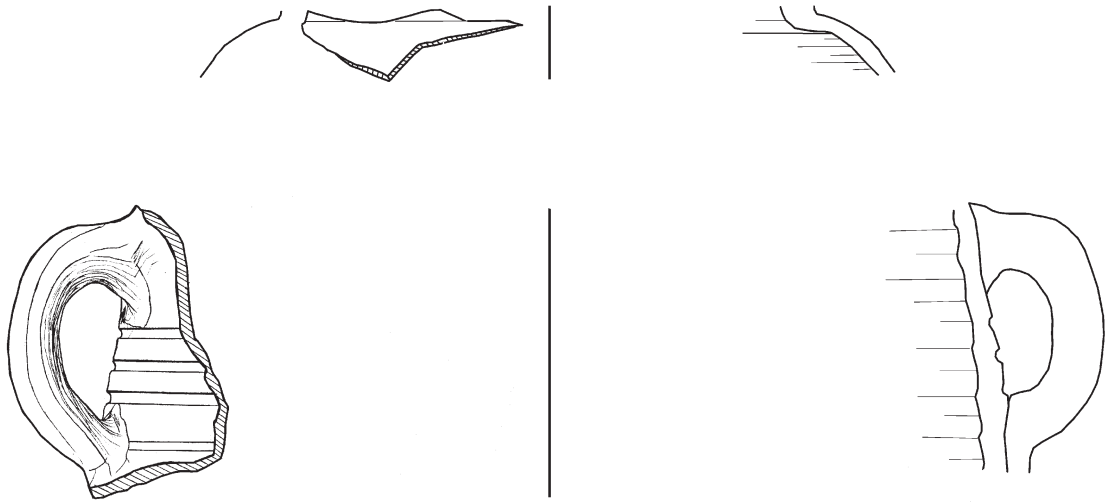
No. 8 C-1339 (2) [012]

0 1cm



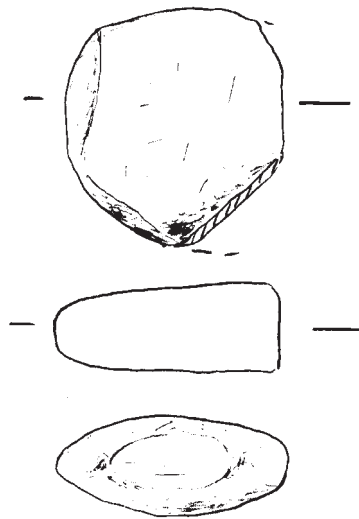
No. 9 P1170A

0 2cm



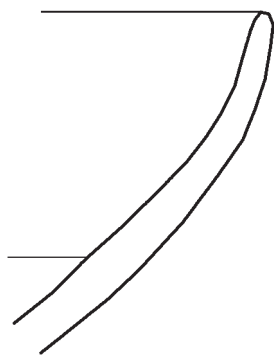
No. 11 P1169A

0 2cm



No. 20 F0946A

0 1cm



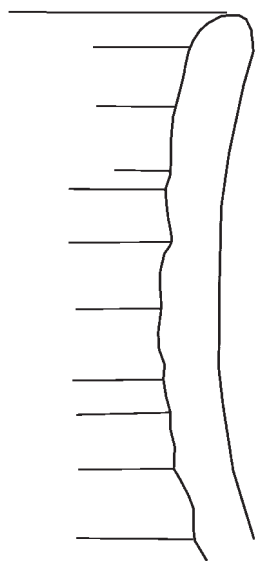
No. 1 C-1337 (2) [005]



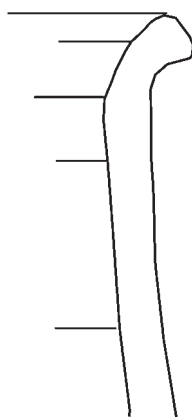
No. 2 C-1337 (2) [006]



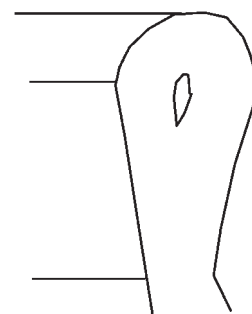
No. 3 C-1337 (2) [007]



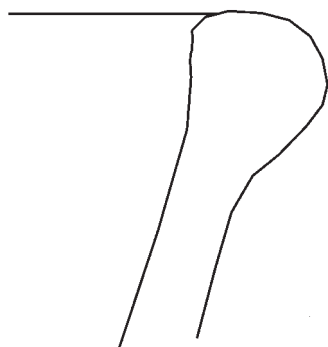
No. 4 C-1337 (2) [003]



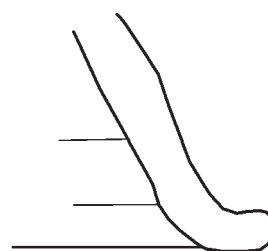
No. 5 C-1337 (2) [004]



No. 7 C-1337 (2) [008]



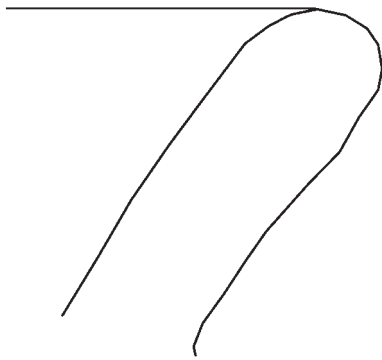
No. 8 C-1337 (2) [009]



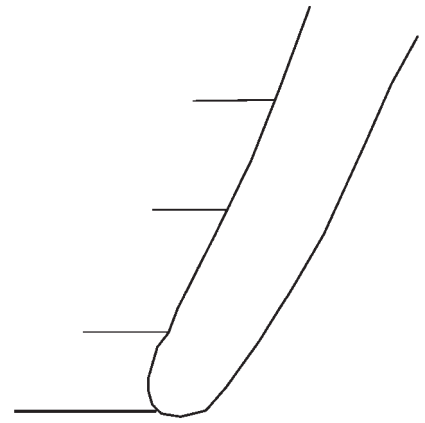
No. 10 C-1337 (2) [014]

0 1cm

Fig. 22:1



No. 11 C-1337 (2) [011]



No. 12 C-1337 (2) [012bis]

=∞= ⊙

No. 19 F0647

0 1cm

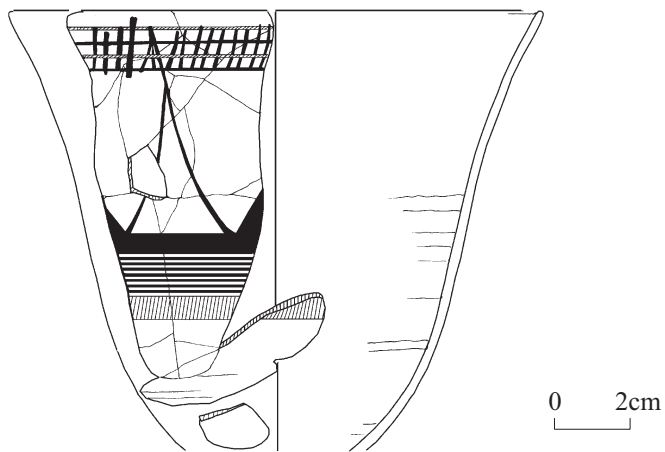
AREA II, L1225

Fig. 22:2

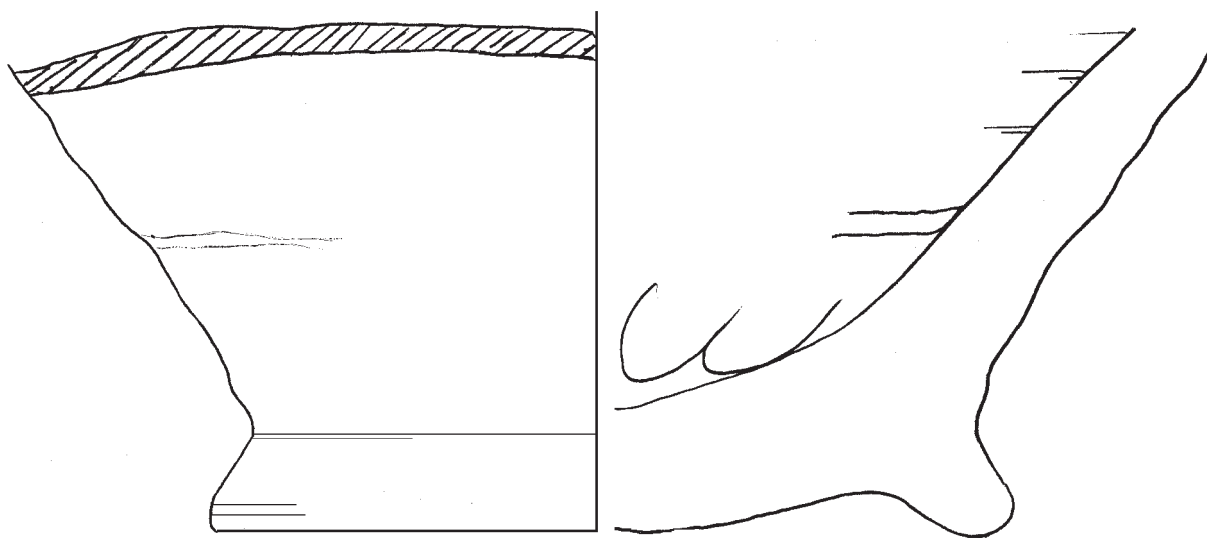


No. 18 F0661

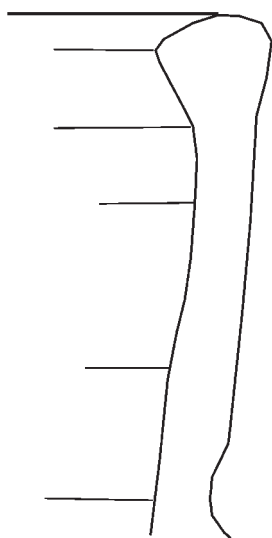
AREA II, L1225



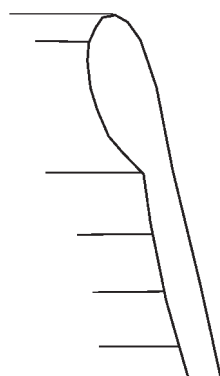
No. 1 P1122A + P1134A



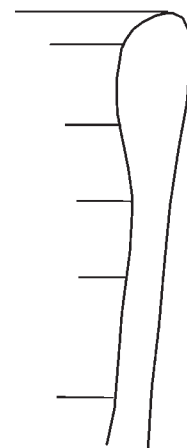
No. 2 P7040A



No. 4 C-1323 [001]



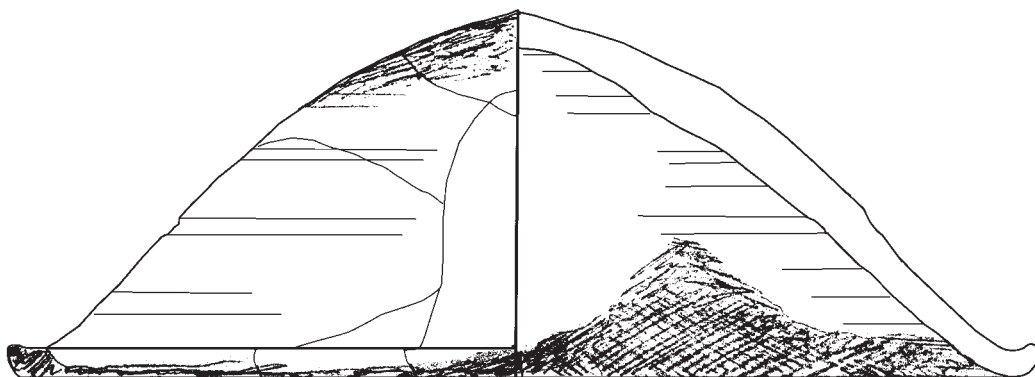
No. 3 C-1323 [010]



No. 5 C-1323 [009]

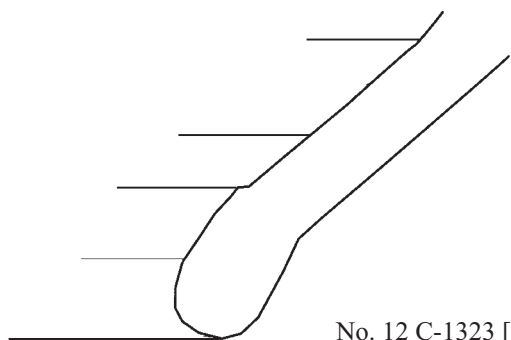
AREA II, L1228 = L1237

Fig. 23:1

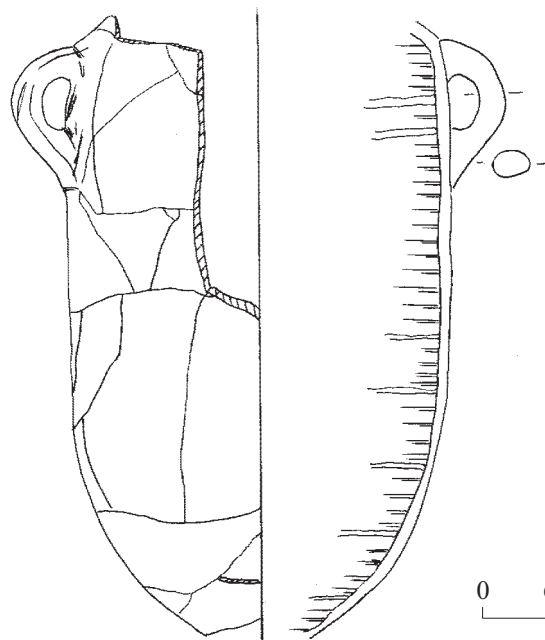


No. 10 P1257A

0 2cm

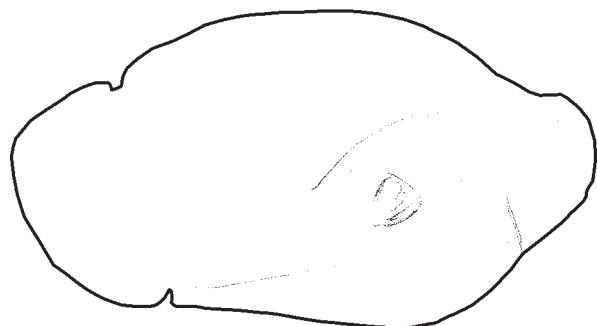
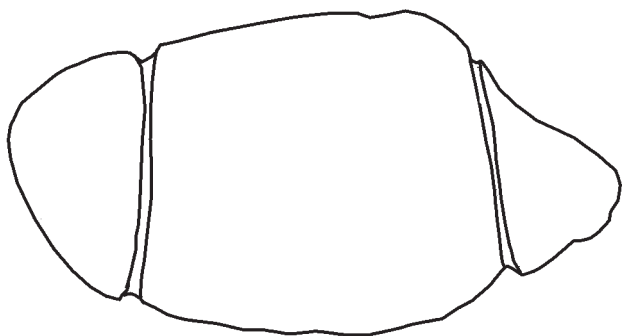


No. 12 C-1323 [016]



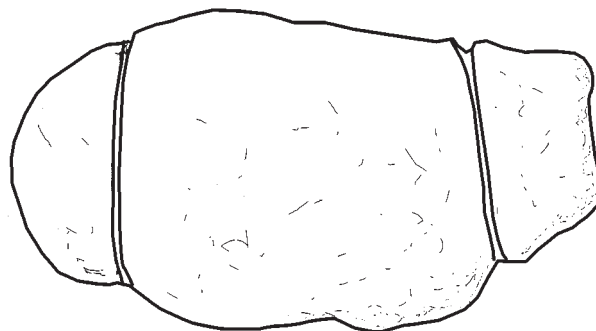
0 6cm

No. 13 P7046A



No. 17 F0538A

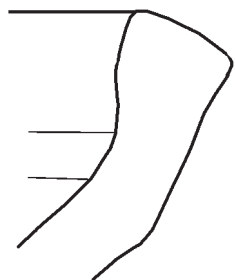
0 1cm



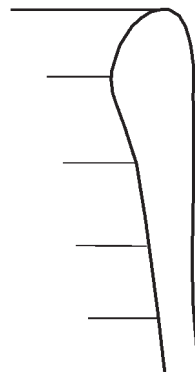
No. 18 F0901A

AREA II, L1228 = L1237

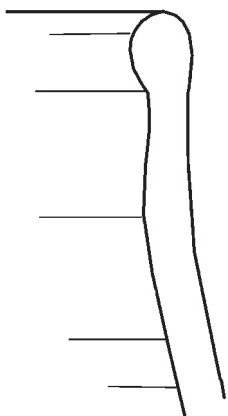
Fig. 23:2



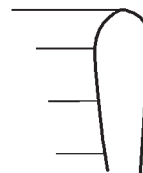
No. 1 C-1328 [001]



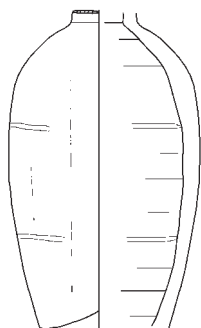
No. 2 C-1328 (2) [002]



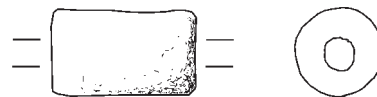
No. 3 C-1328 (2) [001]



No. 4 C-1328 [002]



No. 6 P0010A



No. 7 F0625

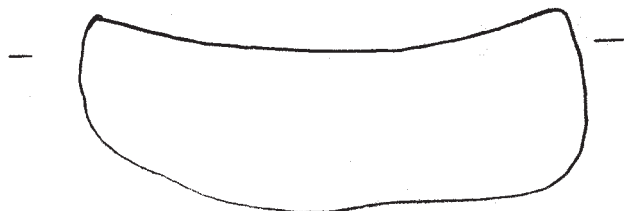
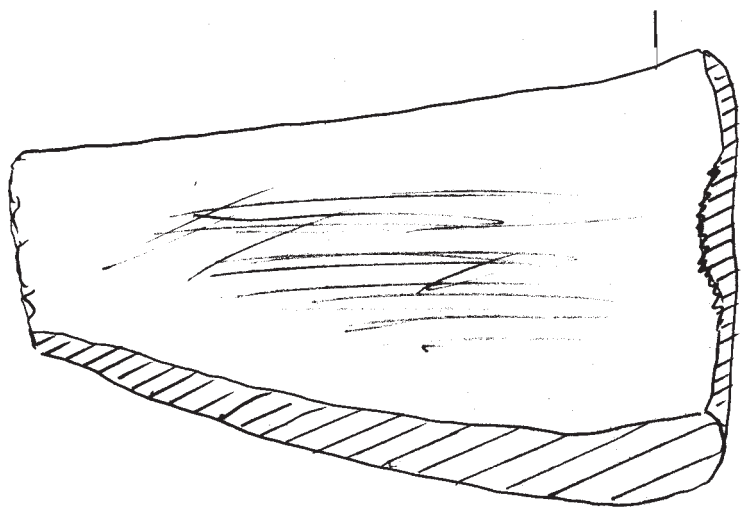
0 1cm

Fig. 24



No. 2 P1128A

0 2cm

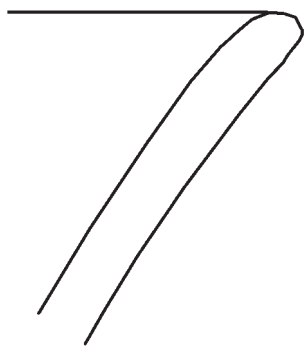


No. 23 F0940A

0 1cm

AREA II, L1230

Fig. 25



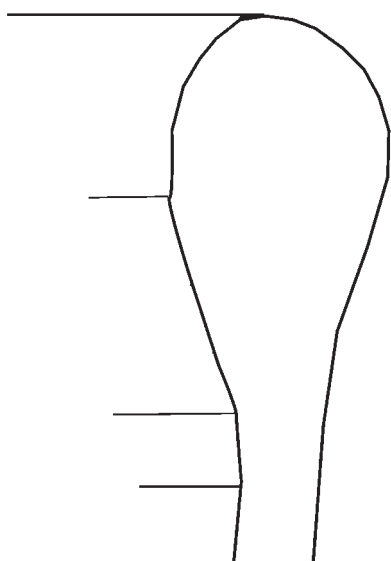
No. 2 C-1317 [010]



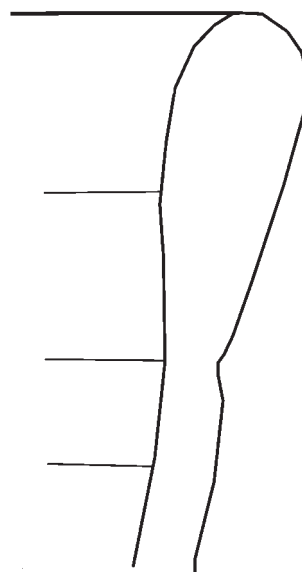
No. 3 C-1317 [006]



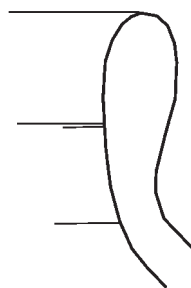
No. 5 C-1317 [009]



No. 8 C-1317 [001]



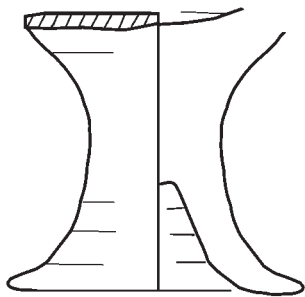
No. 9 C-1317 [004]



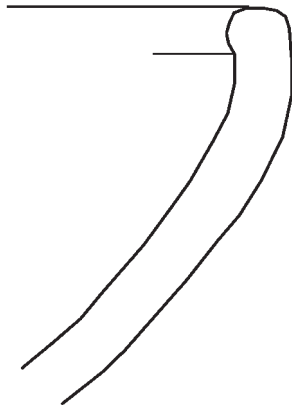
No. 11 C-1317 [005]

0 1cm

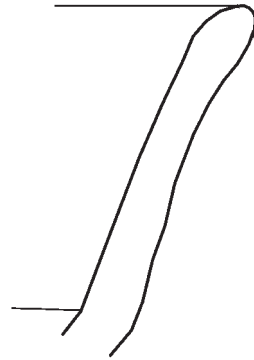
Fig. 26



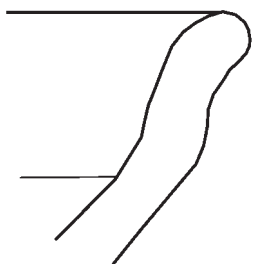
No. 1 P7023A



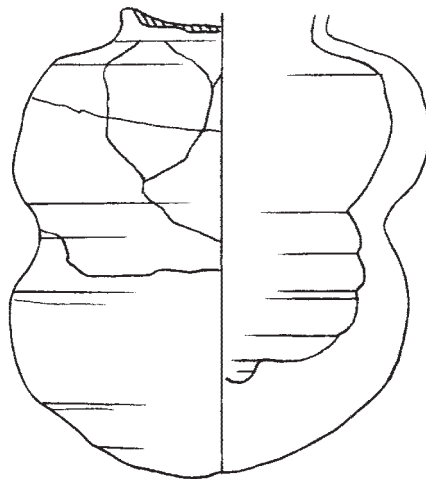
No. 2 C-1301 (3) [001]



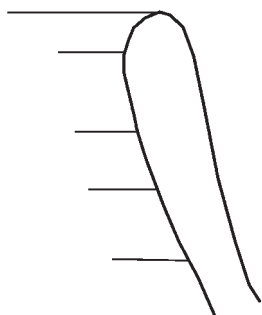
No. 3 C-1301 (3) [003bis]



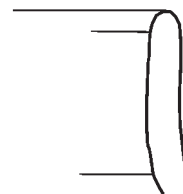
No. 4 C-1301 (3) [004bis]



No. 6 P1154A

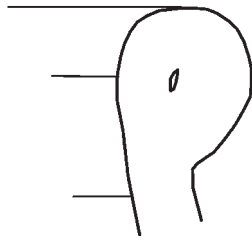


No. 7 C-1301 (3) [003]



No. 8 C-1301 (3) [007]

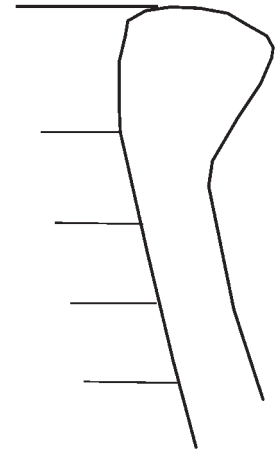
0 1cm



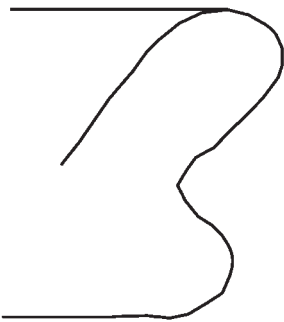
No. 9 C-1301 (1) [005]



No. 10 C-1301 (1) [003]



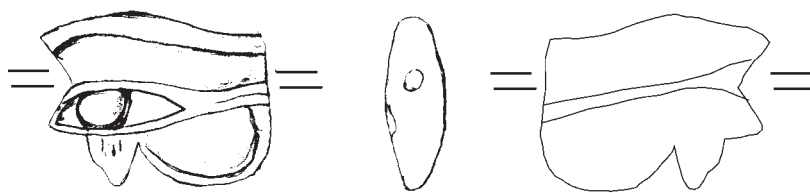
No. 11 C-1301 (1) [001]



No. 13 C-1301 [005]

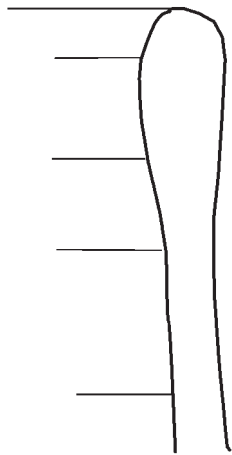


No. 17 P2017A

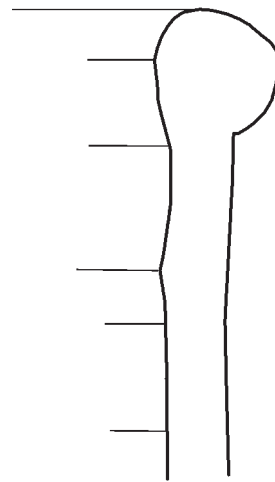


No. 18 F0604

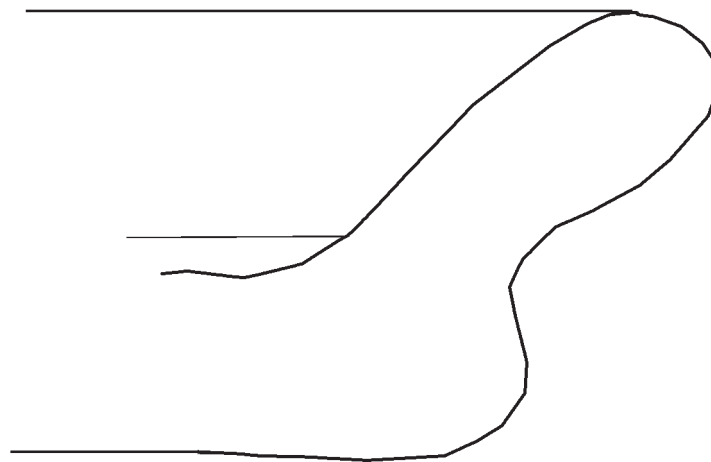
0 1cm



No. 2 C-1335 [002]



No. 4 C-1335 [001]

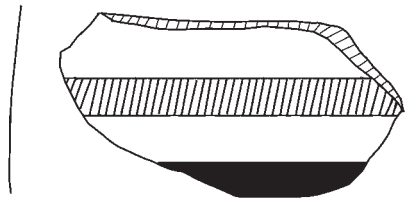


No. 5 C-1335 [006]

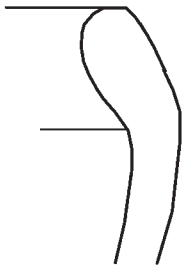
0 1cm

AREA II, L1404

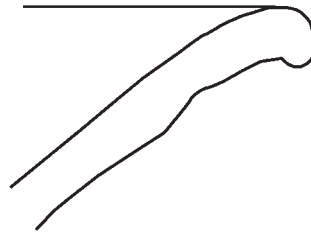
Fig. 28



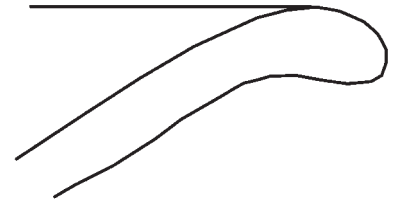
No. 1 P1133A



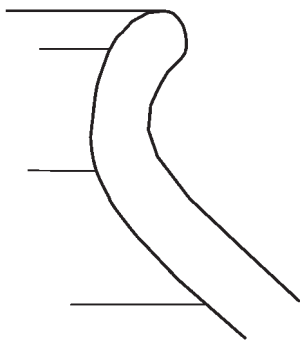
No. 2 C-1302 (2) [008]



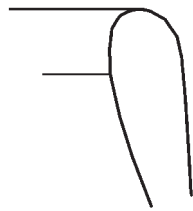
No. 3 C-1302 (2) [012]



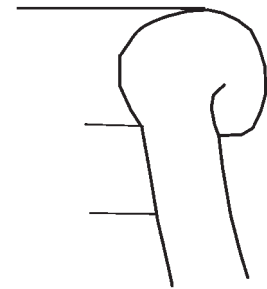
No. 4 C-1302 (2) [011]



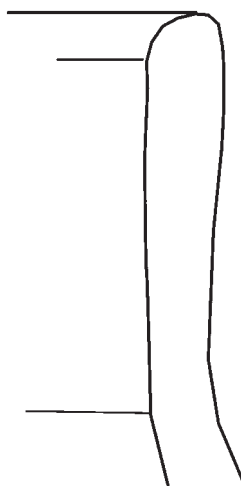
No. 5 C-1302 (2) [004]



No. 6 C-1302 (2) [042]



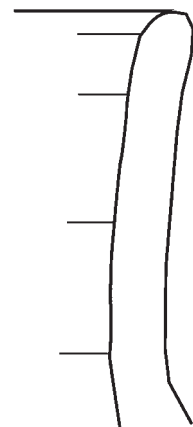
No. 7 C-1302 (2) [034]



No. 8 C-1302 (2) [031]



No. 9 C-1302 (2) [013]

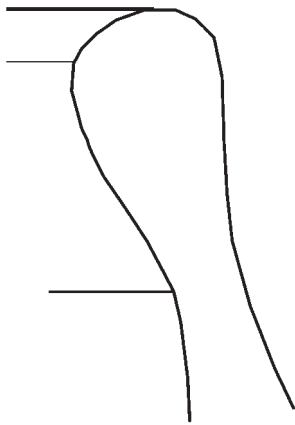


No. 10 C-1302 (2) [006]

0 1cm

AREA II, L1406

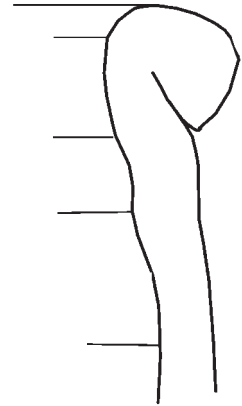
Fig. 29:1



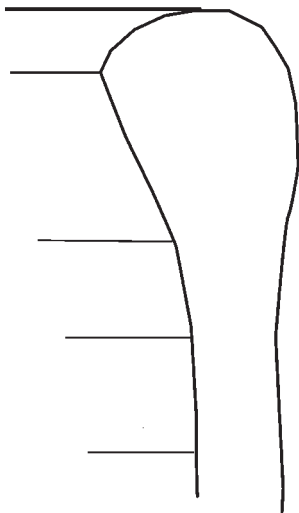
No. 13 C-1302 (2) [001]



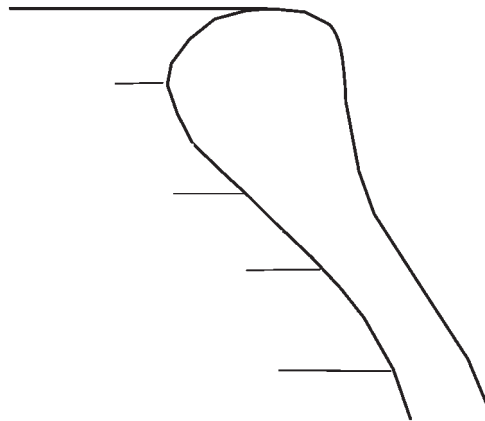
No. 14 C-1302 (2) [007]



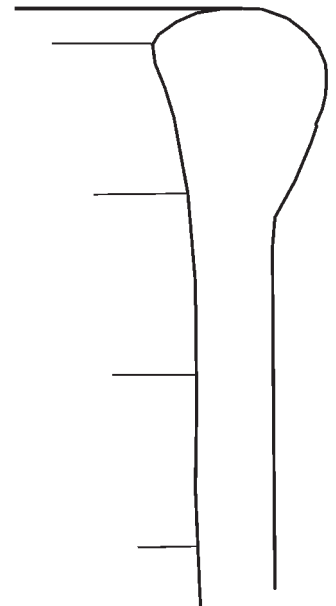
No. 15 C-1302 (2) [026]



No. 16 C-1302 (2) [030]



No. 17 C-1302 (2) [029]

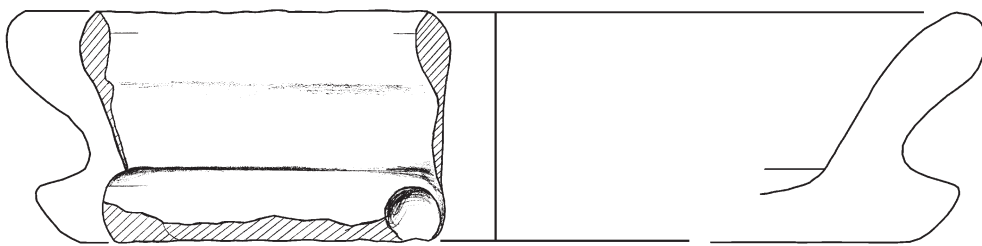


No. 19 C-1302 (2) [059]



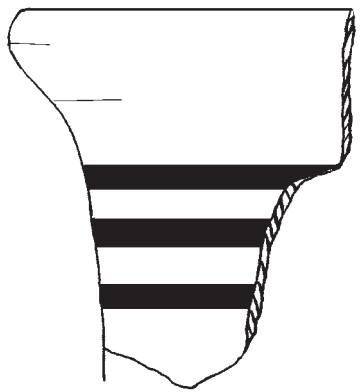
No. 20 C-1302 (2) [010]

0 1cm

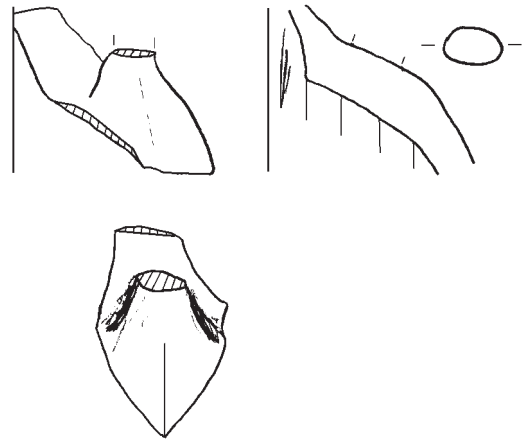
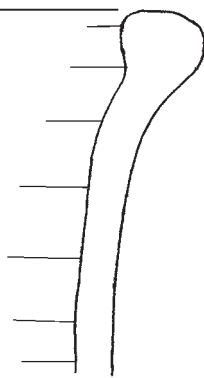


0 2cm

No. 21 P1308A



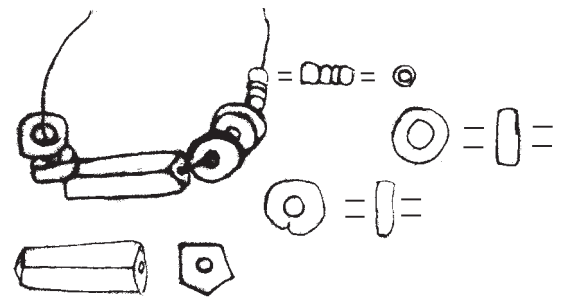
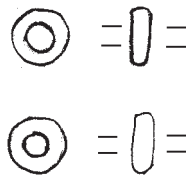
No. 24 P1104A



No. 29 P1105A



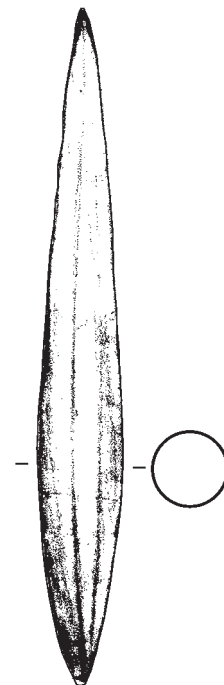
No. 30 F0686



No. 31 F0679



No. 33 F0598A



No. 34 F0632

0 1cm

AREA II, L1406

Fig. 29:3



No. 37 F0934A

0 1cm

AREA II, L1406

Fig. 29:4

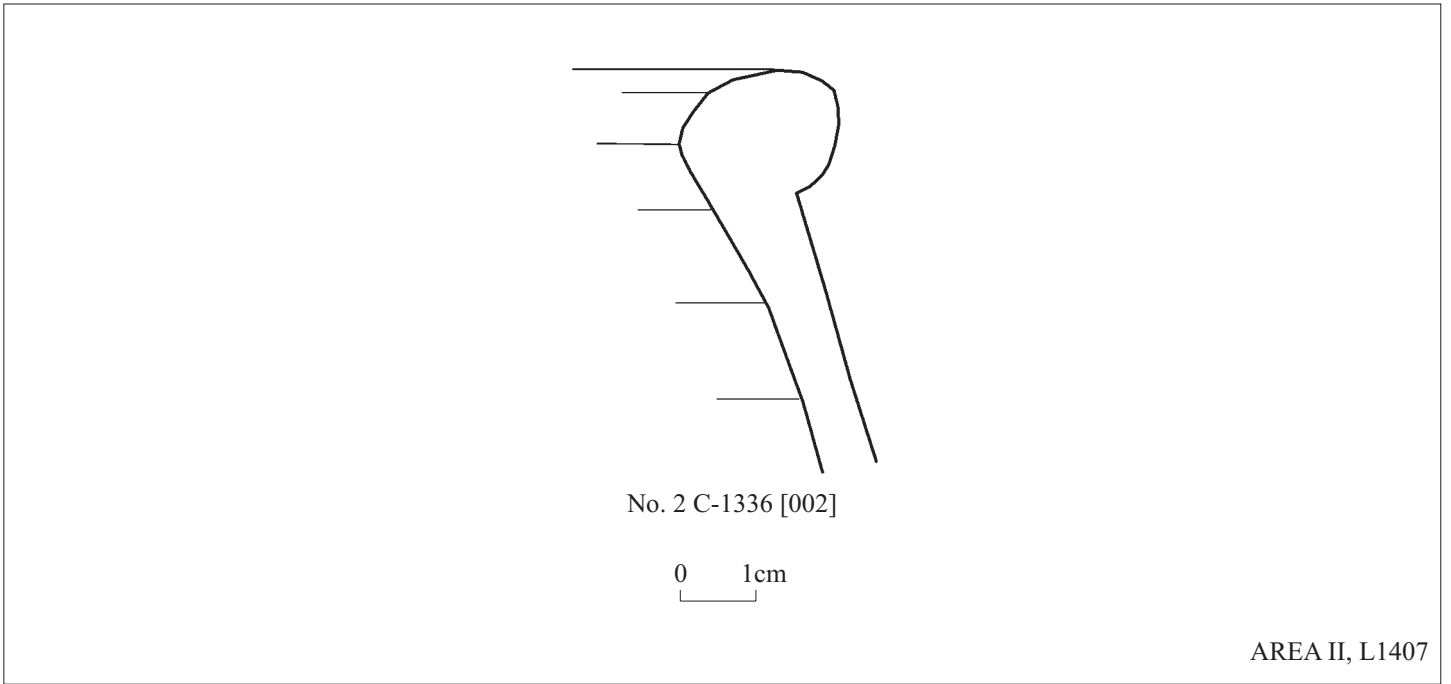


Fig. 30

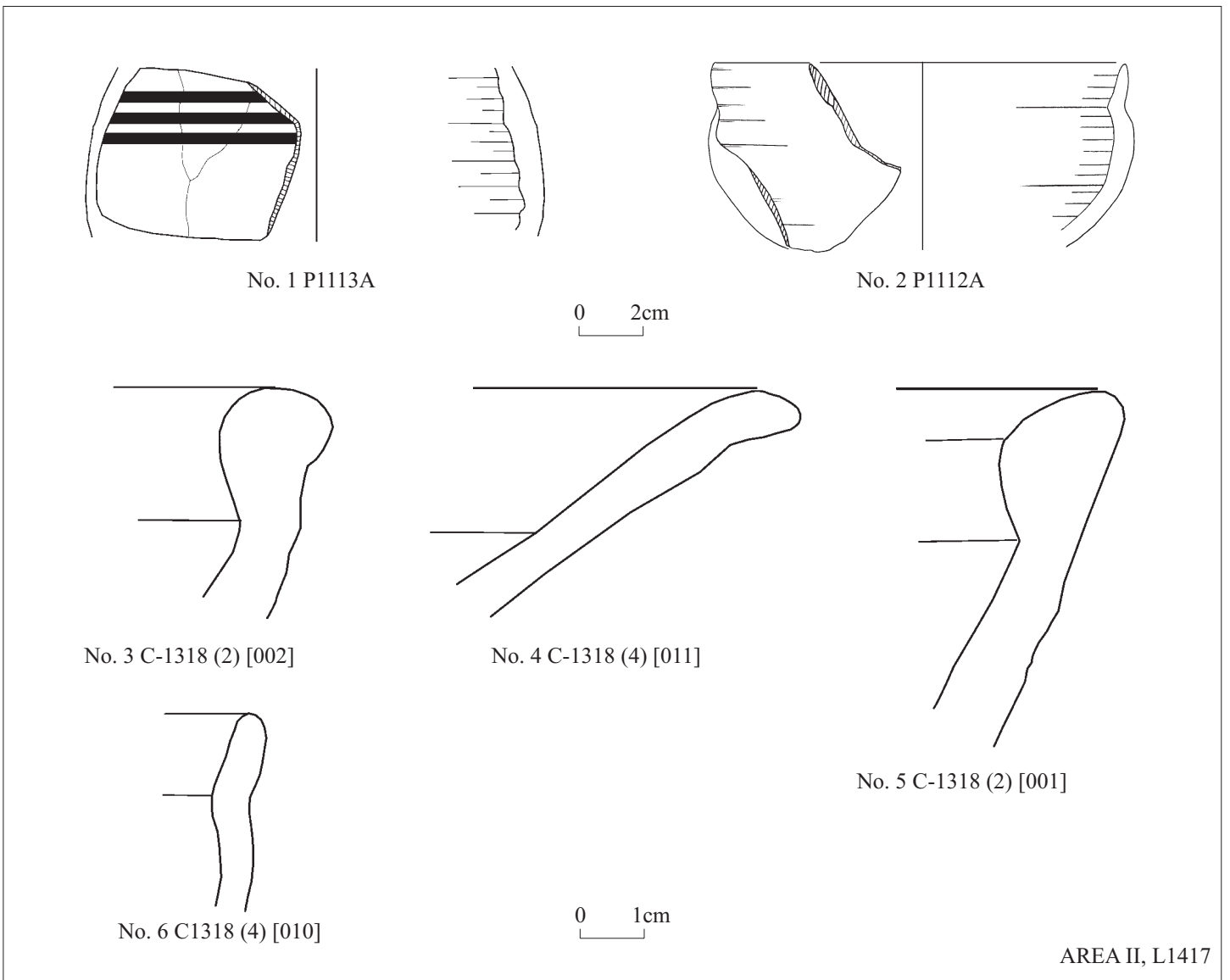
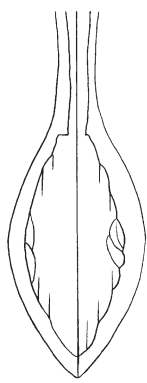
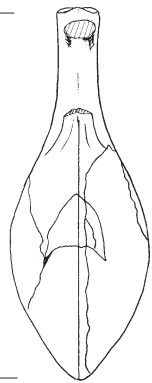
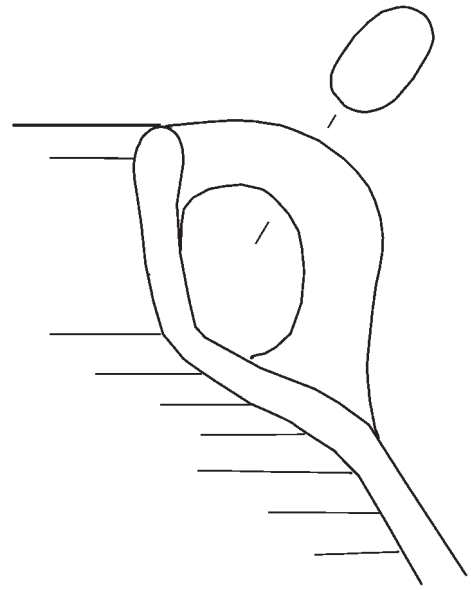


Fig. 31:1

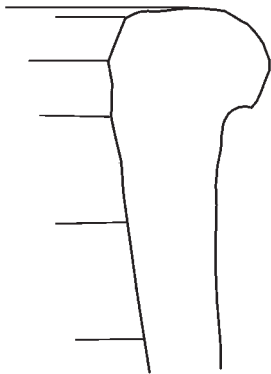


No. 7 P1153A

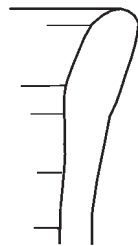
0 2cm



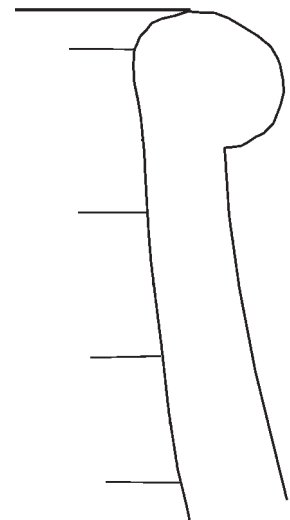
No. 8 C-1318 (4) [020]



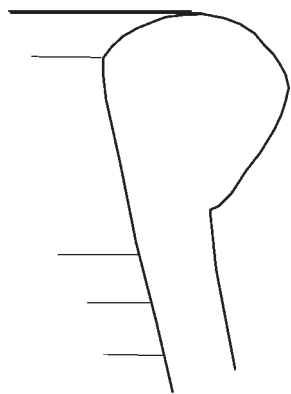
No. 9 C-1318 (2) [005]



No. 10 C-1318 (4) [009]

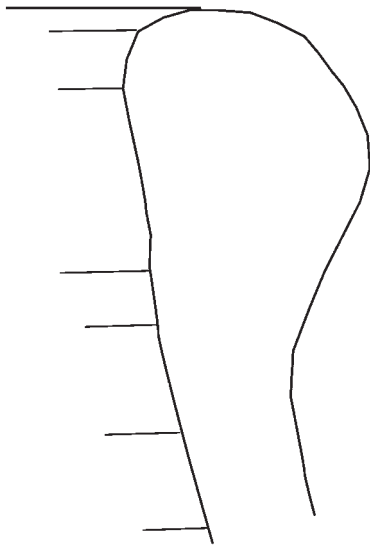


No. 15 C-1318 (2) [003]

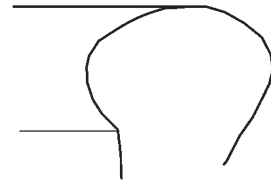


No. 16 C-1318 (4) [001]

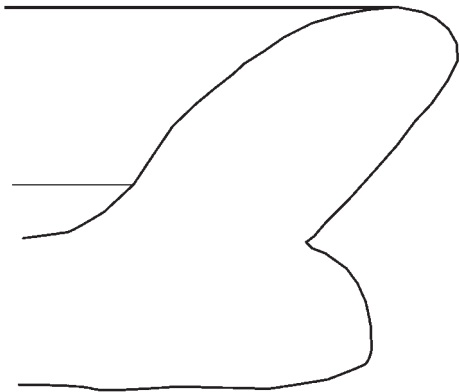
0 1cm



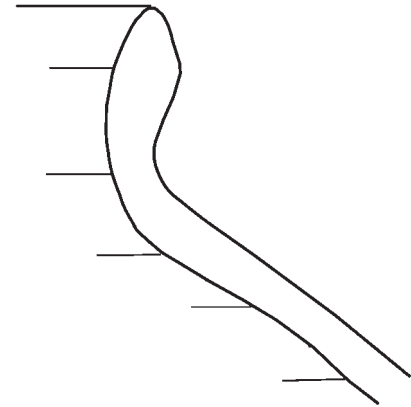
No. 17 C-1318 (4) [003]



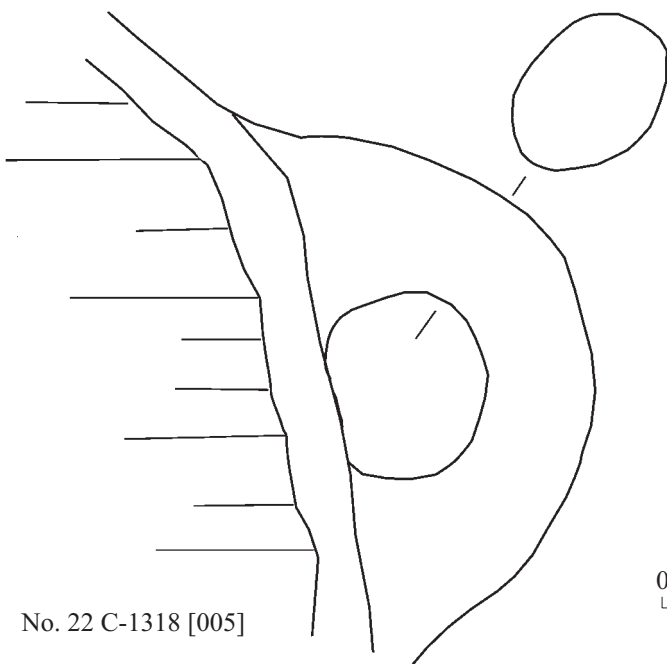
No. 18 C-1318 (4) [005]



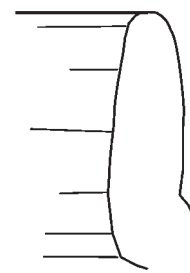
No. 19 C-1318 (4) [004]



No. 21 C-1318 (3) [001]

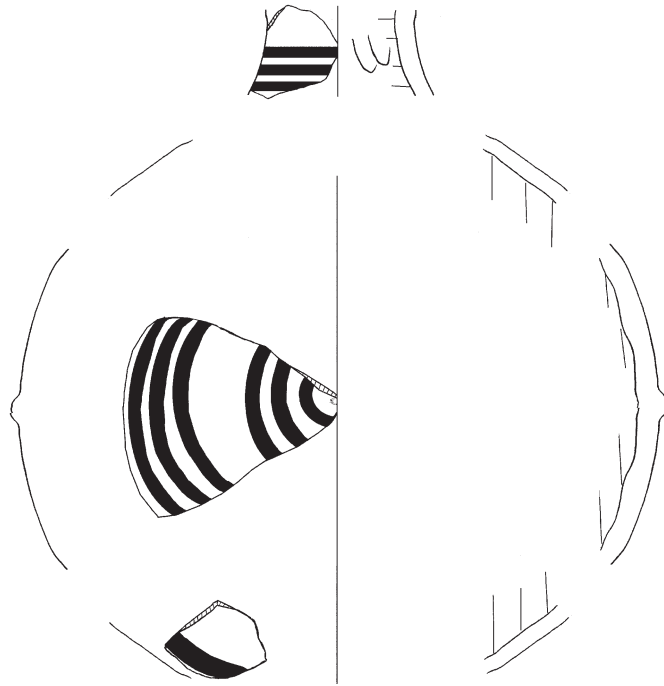


No. 22 C-1318 [005]



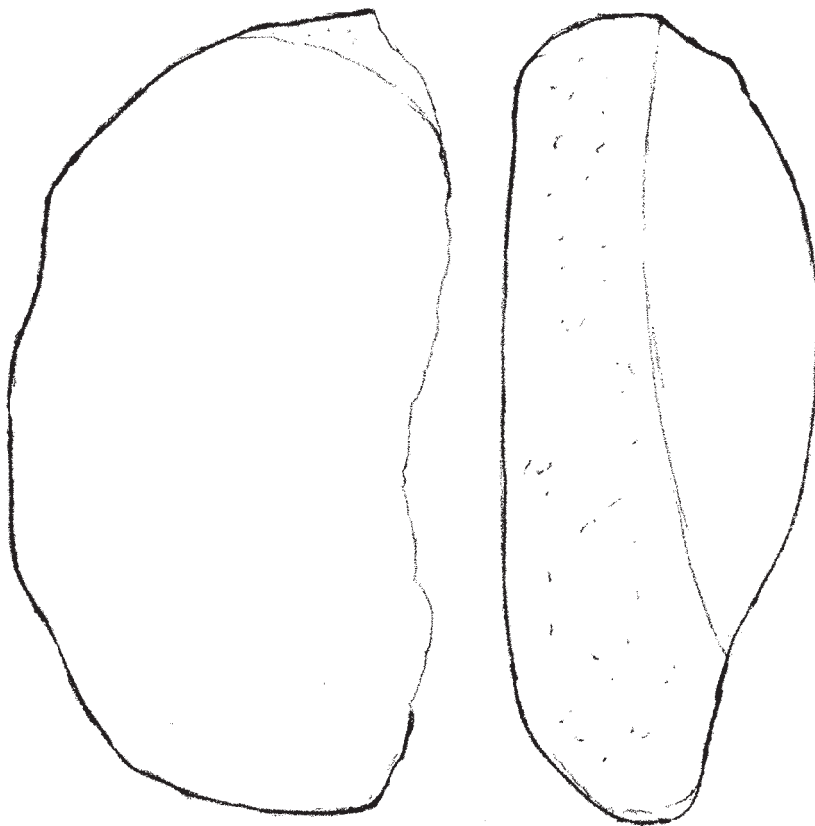
No. 27 C-1318 (2) [009]

0 1cm



No. 28 P1148A

0 2cm



No. 30 F0910A

0 1cm

AREA II, L1417

Fig. 31:4

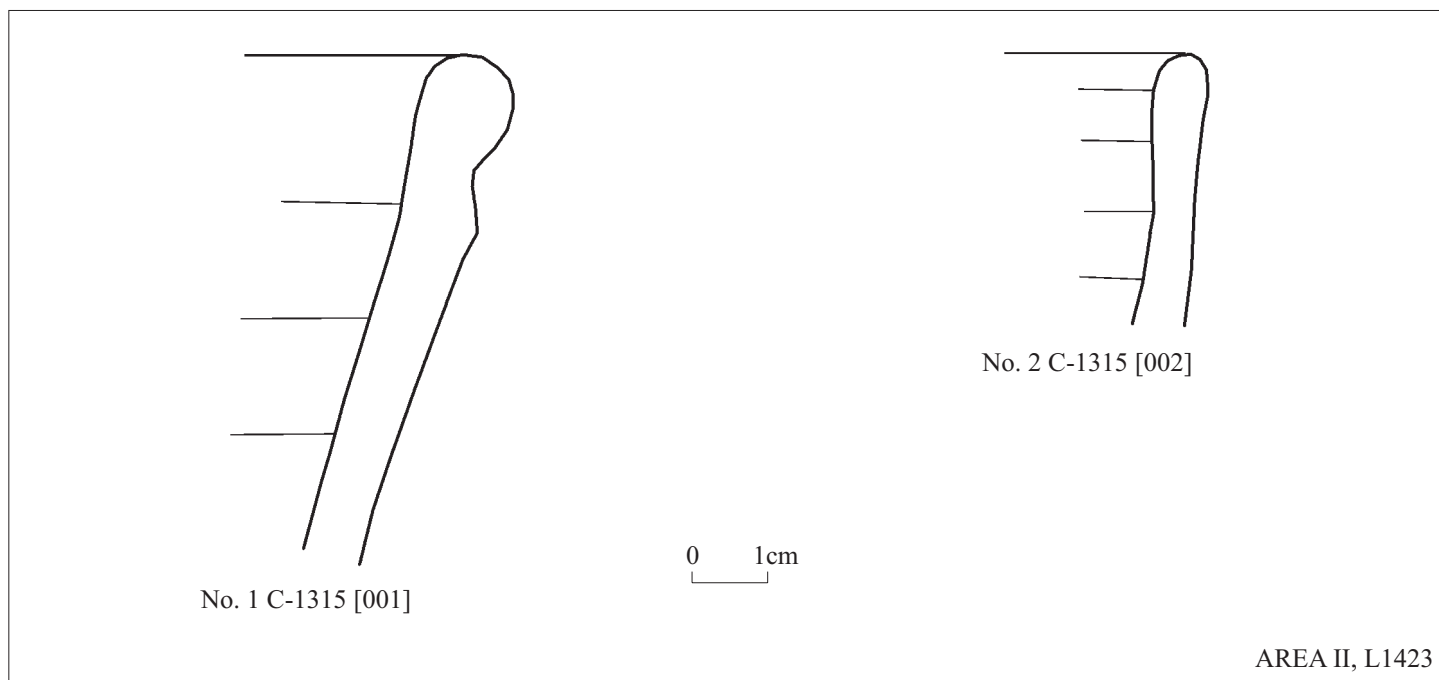


Fig. 32

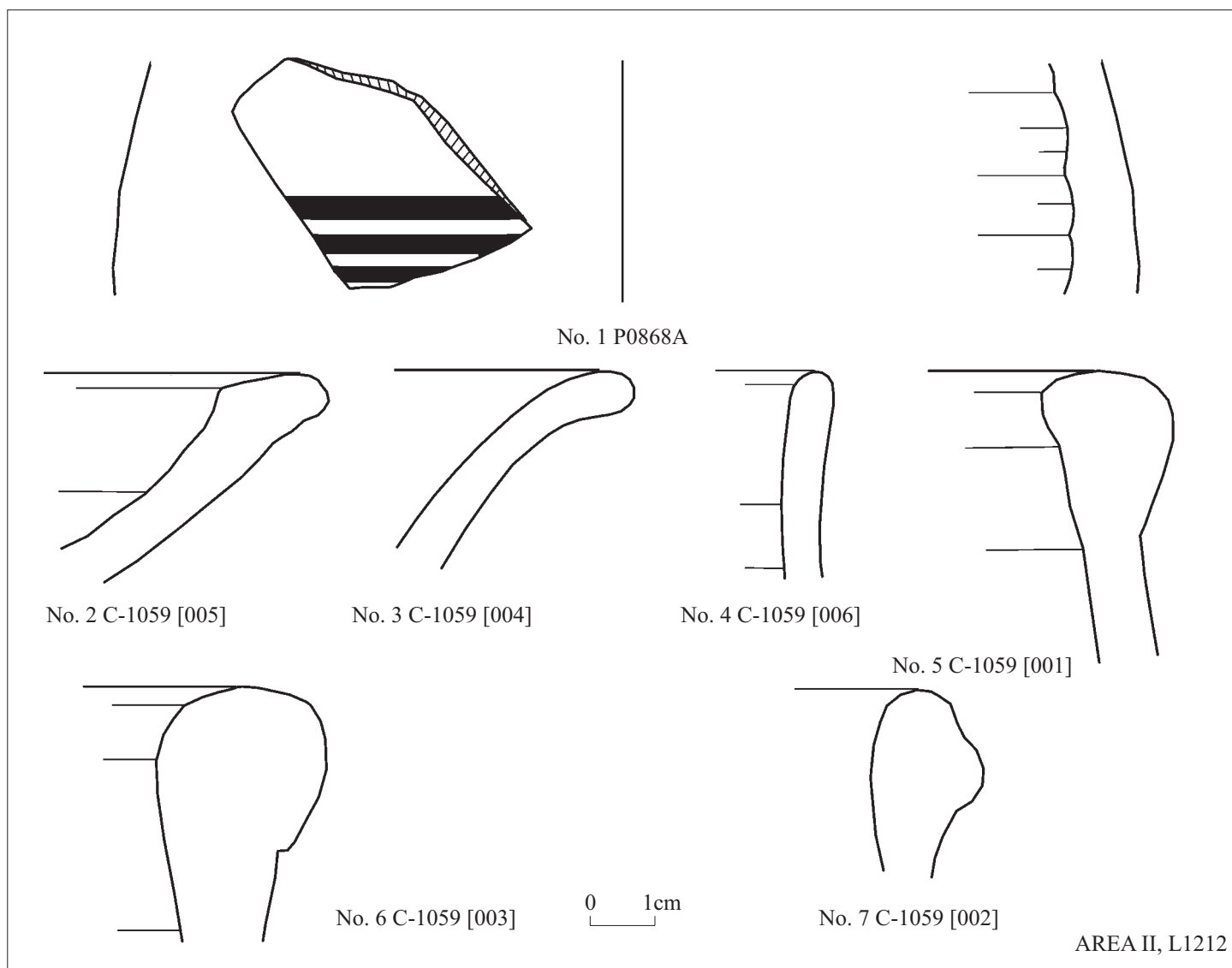


Fig. 33

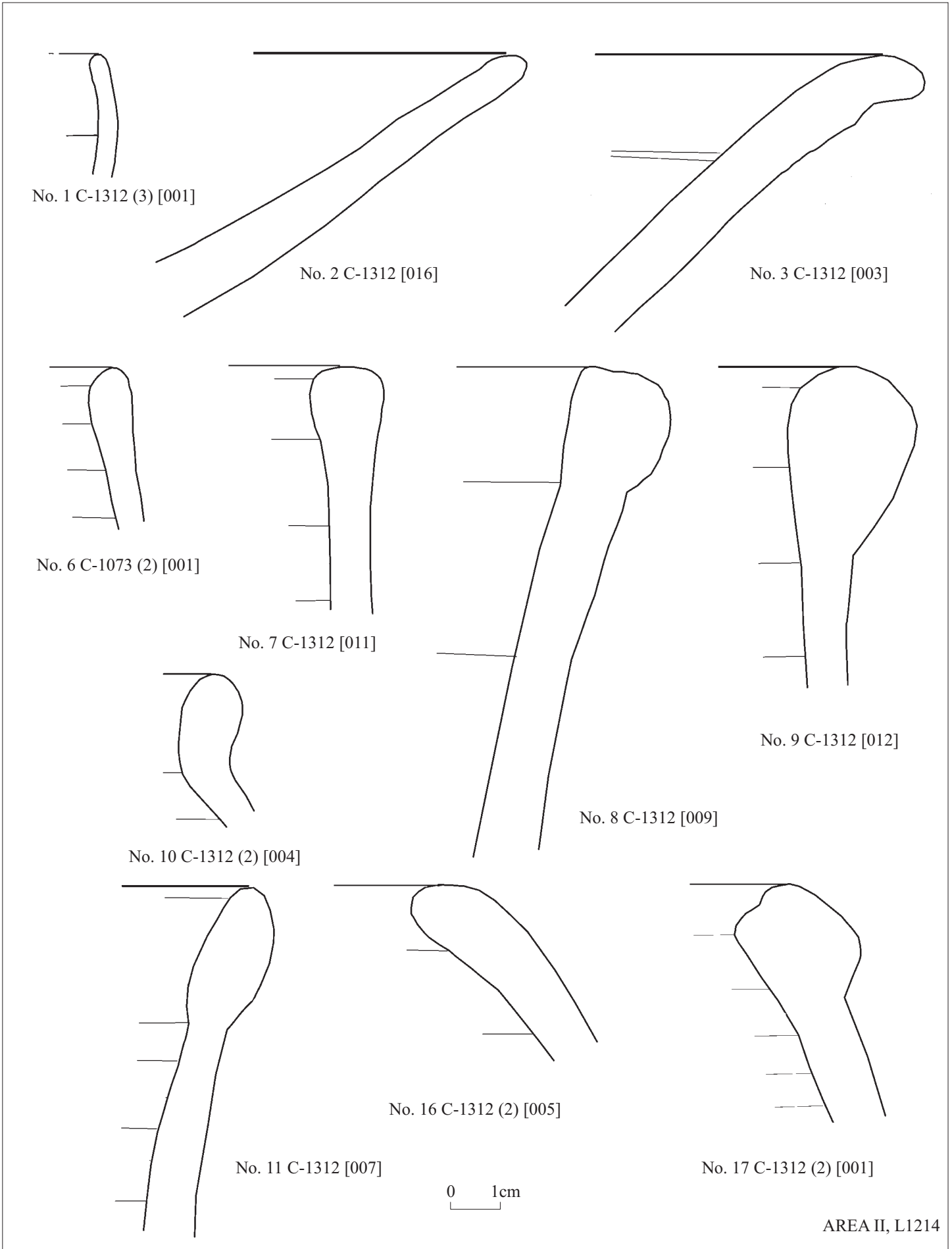
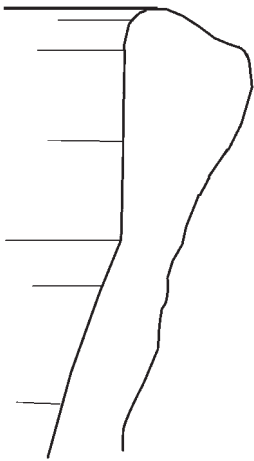
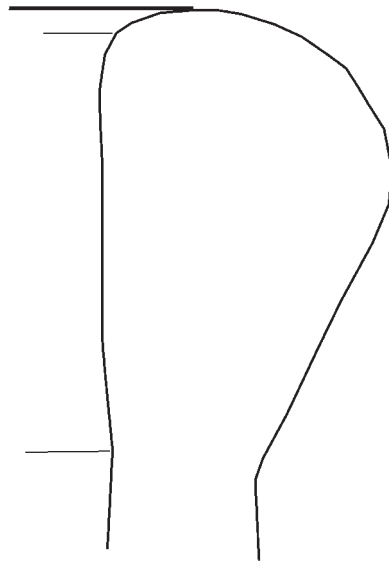


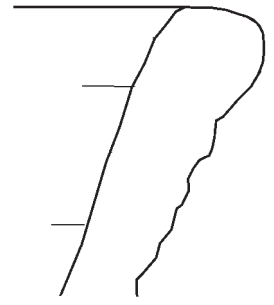
Fig. 34:1



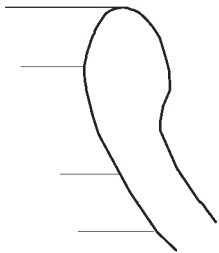
No. 18 C-1312 [002]



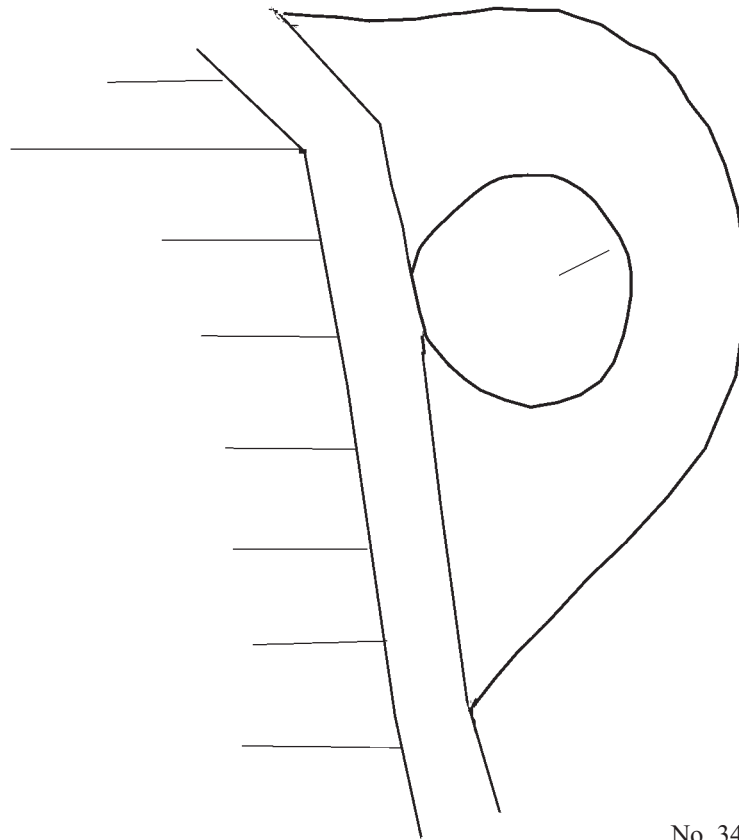
No. 19 C-1312 [008]



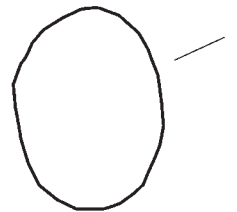
No. 20 C-1312 [001]



No. 33 C-1312 (2) [002]



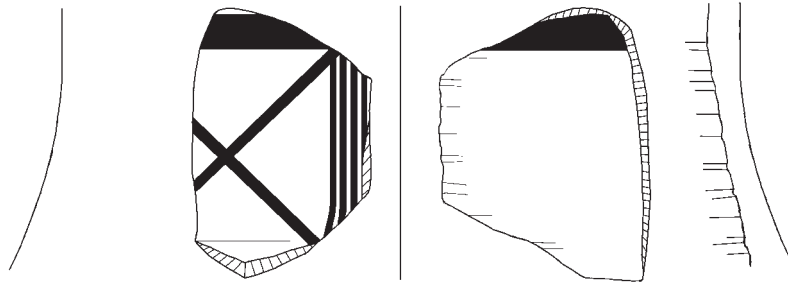
No. 34 C-1312 [018]



0 1cm

AREA II, L1214

Fig. 34:2

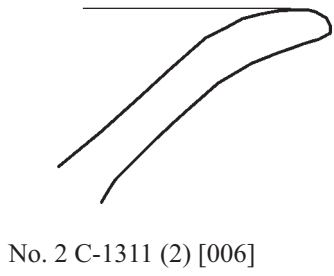


No. 36 P1150A

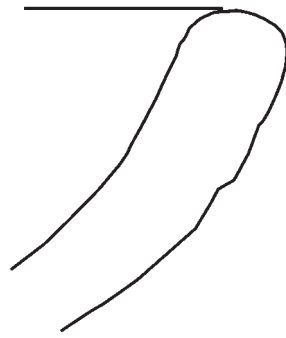


No. 37 P1150Abis

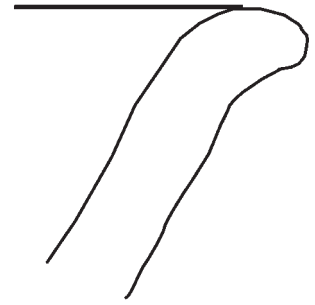
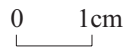
0 2cm



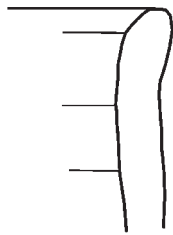
No. 2 C-1311 (2) [006]



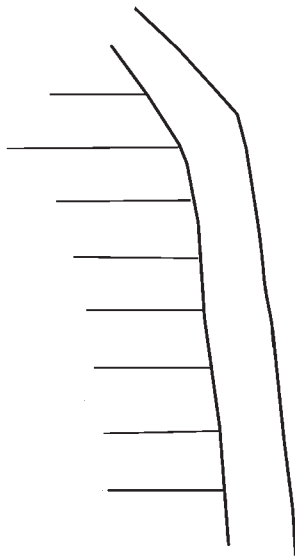
No. 3 C-1311 (2) [005]



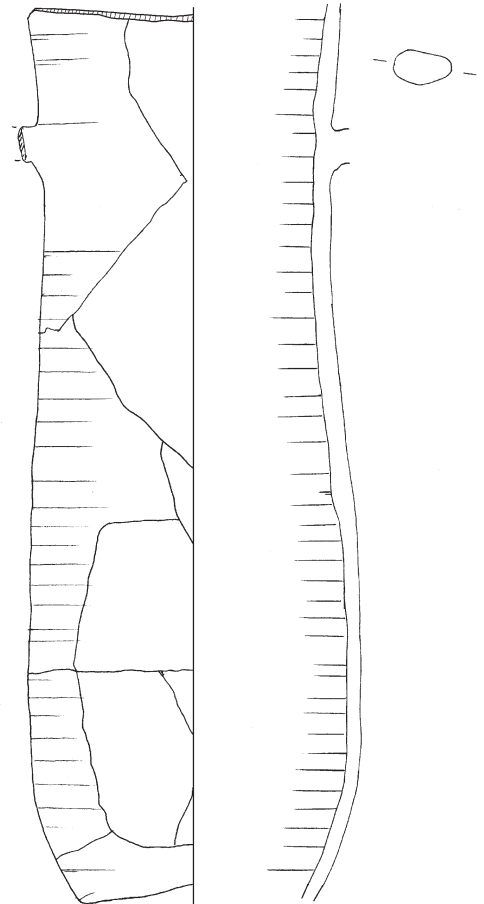
No. 4 C-1311 (2) [002]



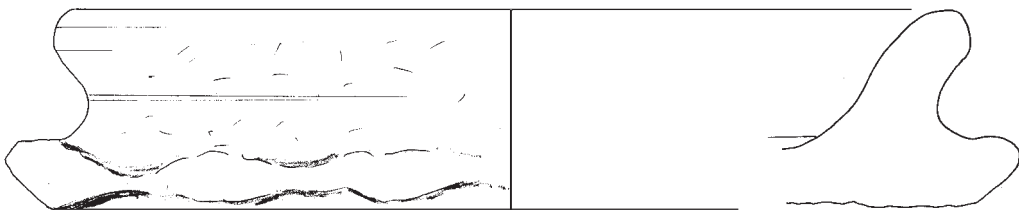
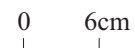
No. 6 C-1311 (2) [012]



No. 10 C-1311 (2) [011]



No. 8 P1206A

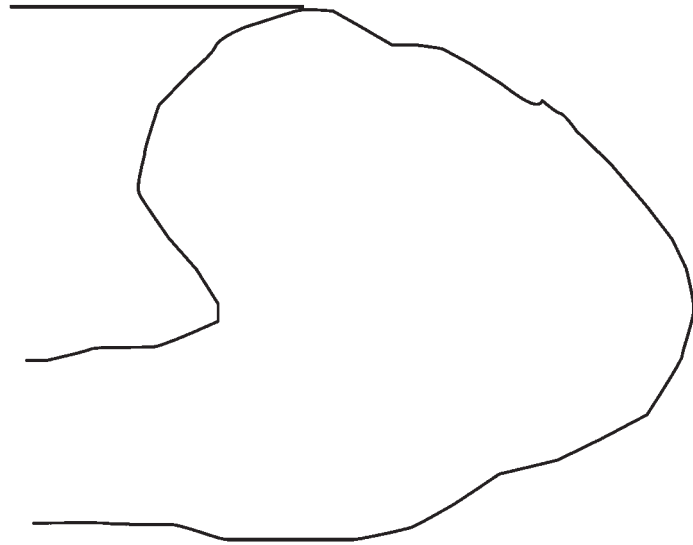


No. 11 P7050A

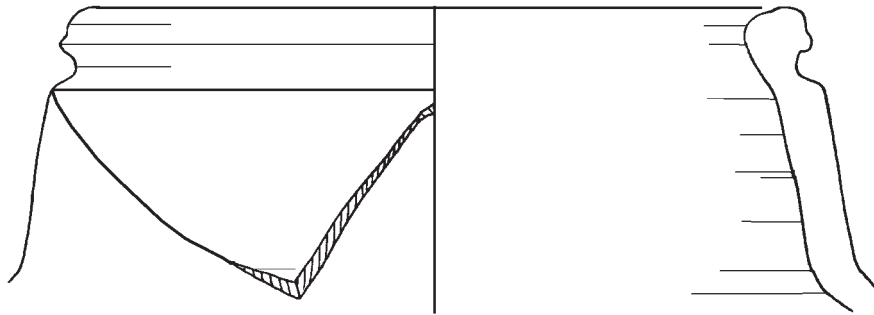


AREA II, L1219

Fig. 35:1

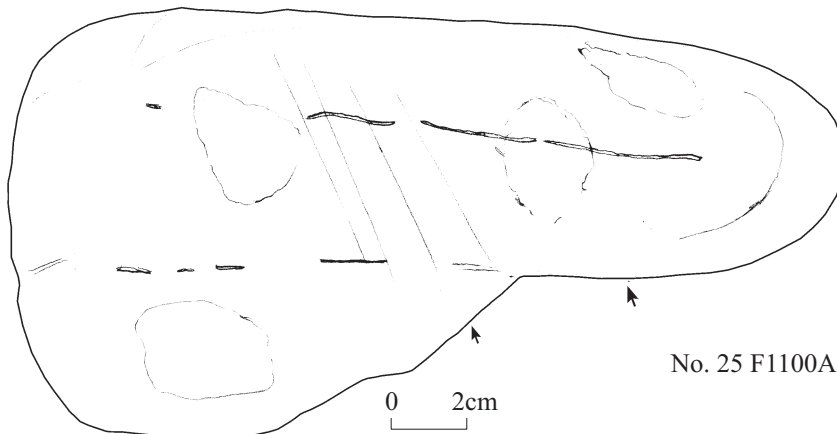
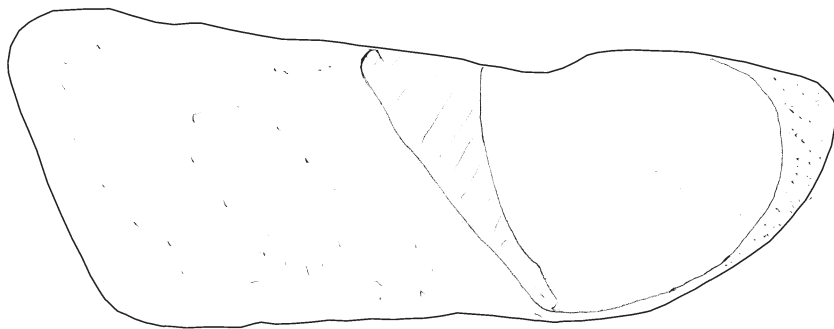


No. 12 C-1311(2) [013]



No. 13 P1208A

0 1cm

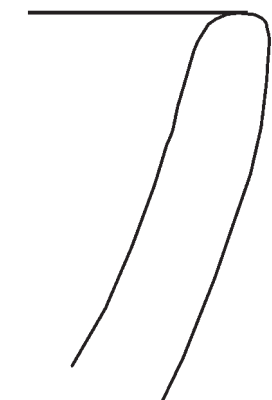


No. 25 F1100A

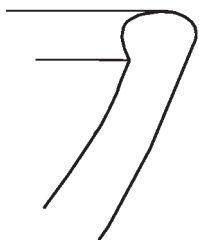
0 2cm

AREA II, L1219

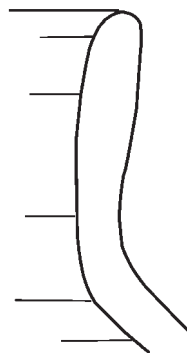
Fig. 35:2



No. 1 C-1330 (3) [002]



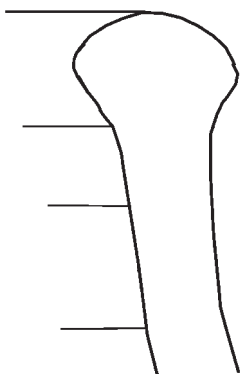
No. 3 C-1330 (3) [006]



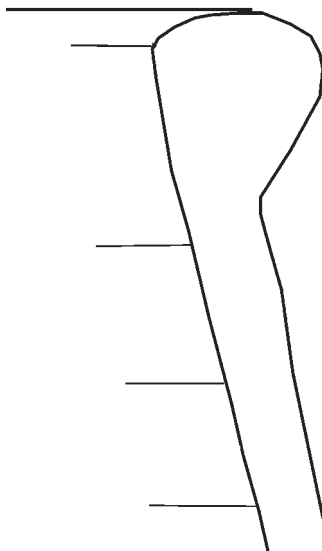
No. 4 C-1330 (2) [003]



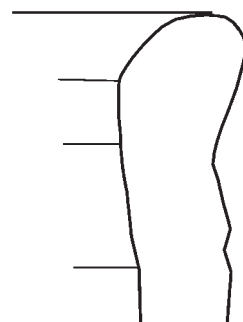
No. 5 C-1330 (2) [017]



No. 10 C-1330 (3) [003]

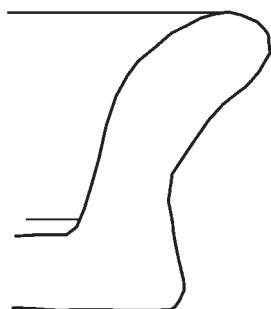


No. 11 C-1330 (3) [001]



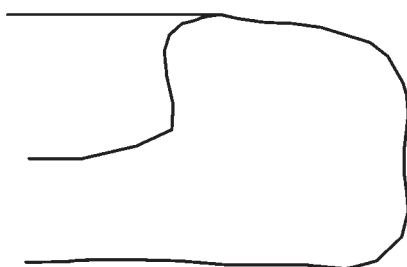
No. 12 C-1330 (2) [016]

0 1cm



No. 15 C-1330 (3) [008]

0 1cm



No. 16 C-1330 (3) [010]

0 2cm



No. 17 C-1311 (2) [005]

0 1cm

Fig. 36

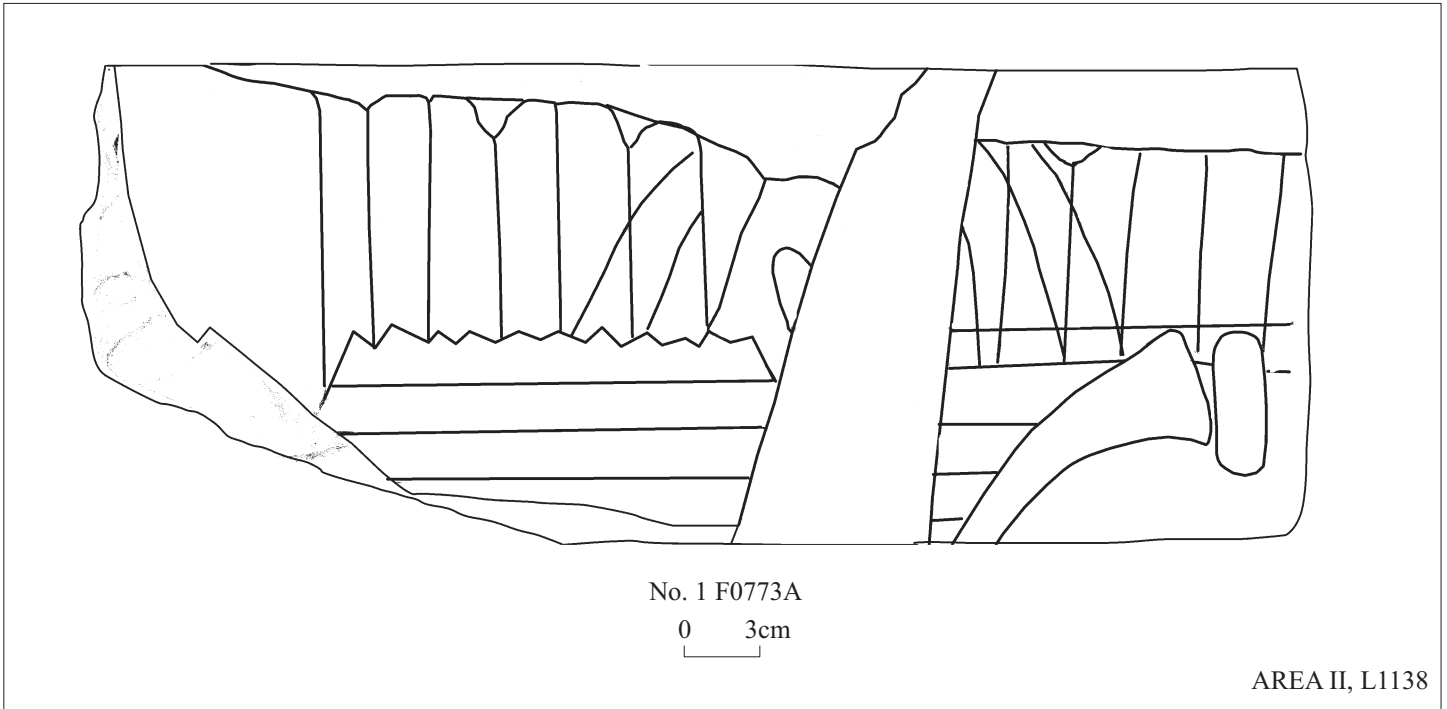


Fig. 37

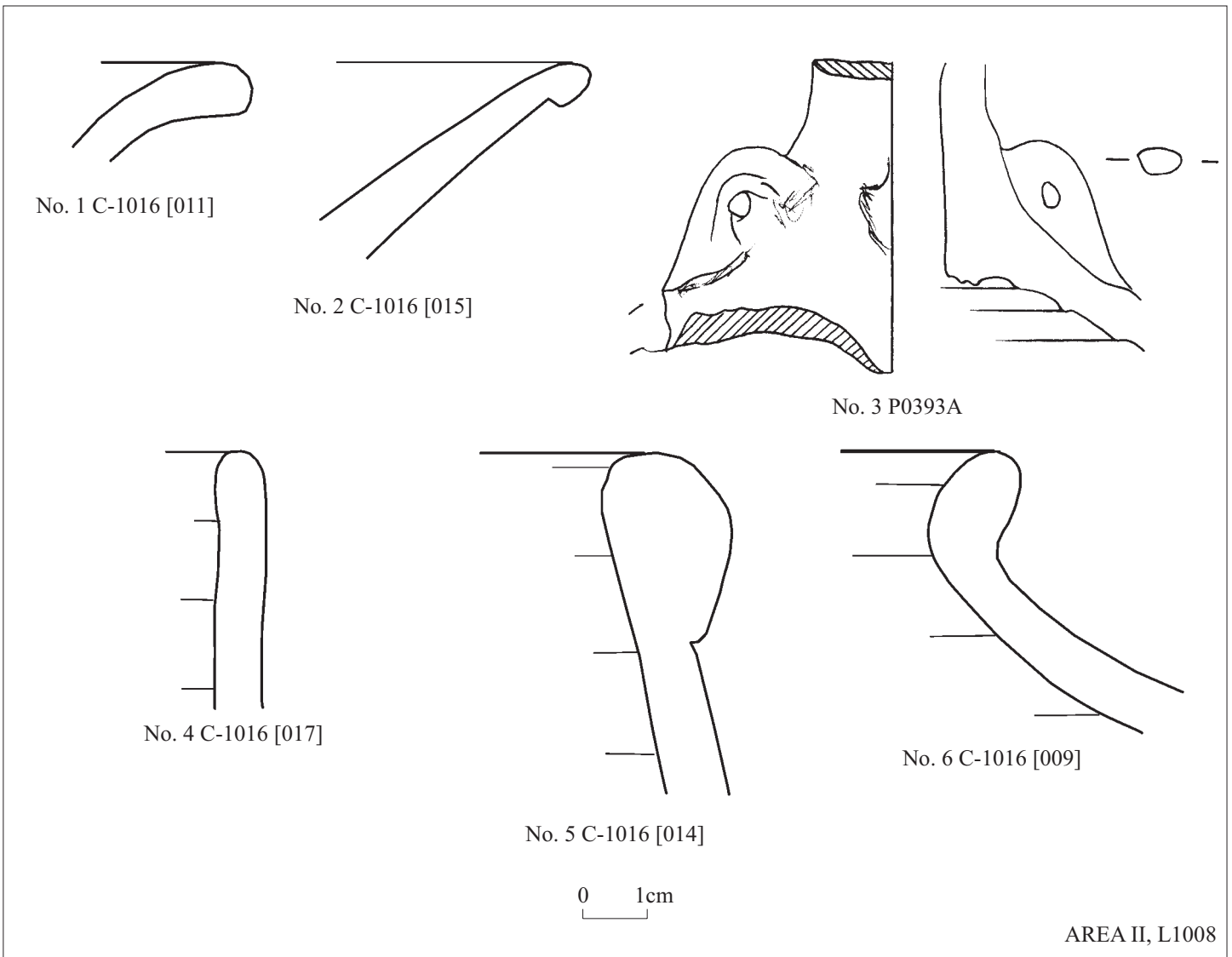
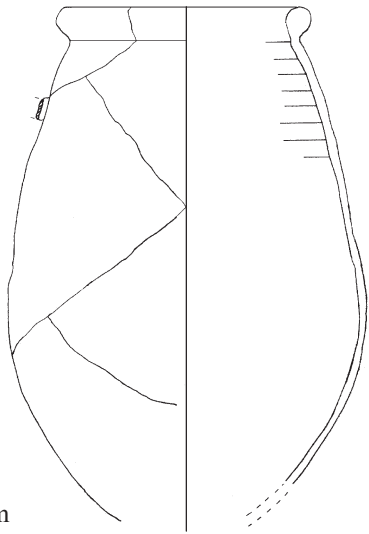
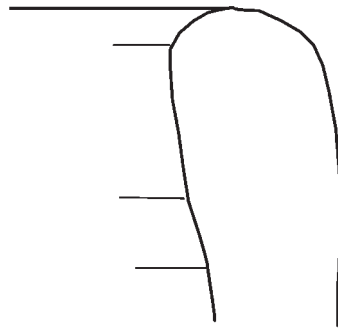


Fig. 38:1

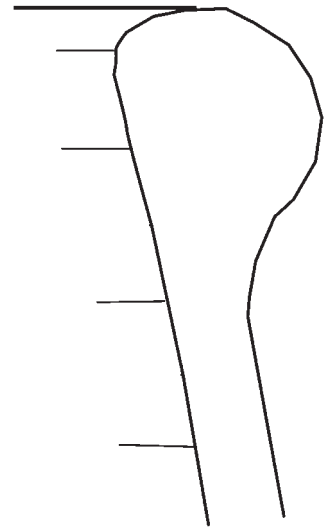


No. 8 P0300A

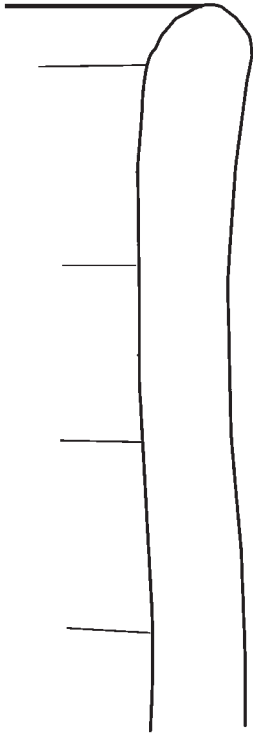
0 9cm



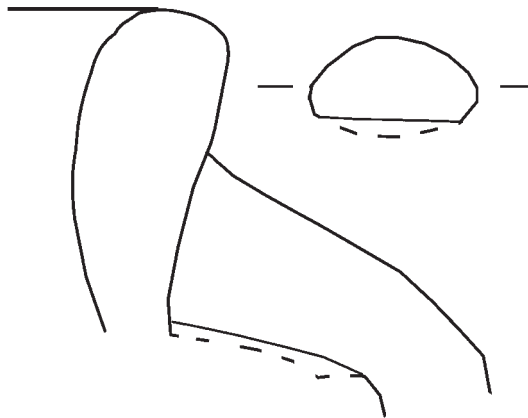
No. 9 C-1016 [013]



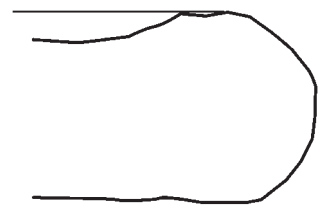
No. 10 C-1016 [003]



No. 11 C-1003 [001]



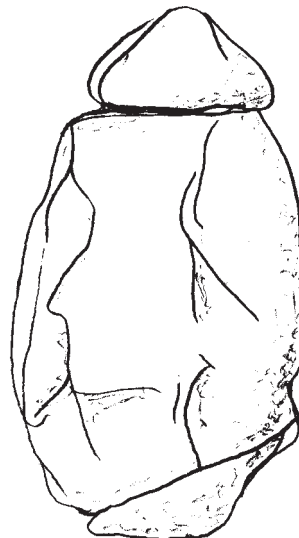
No. 12 C-1016 [020]



No. 15 C-1016 [004]



No. 18 P0382A



No. 19 F0234A

0 1cm

AREA II, L1008

Fig. 38:2

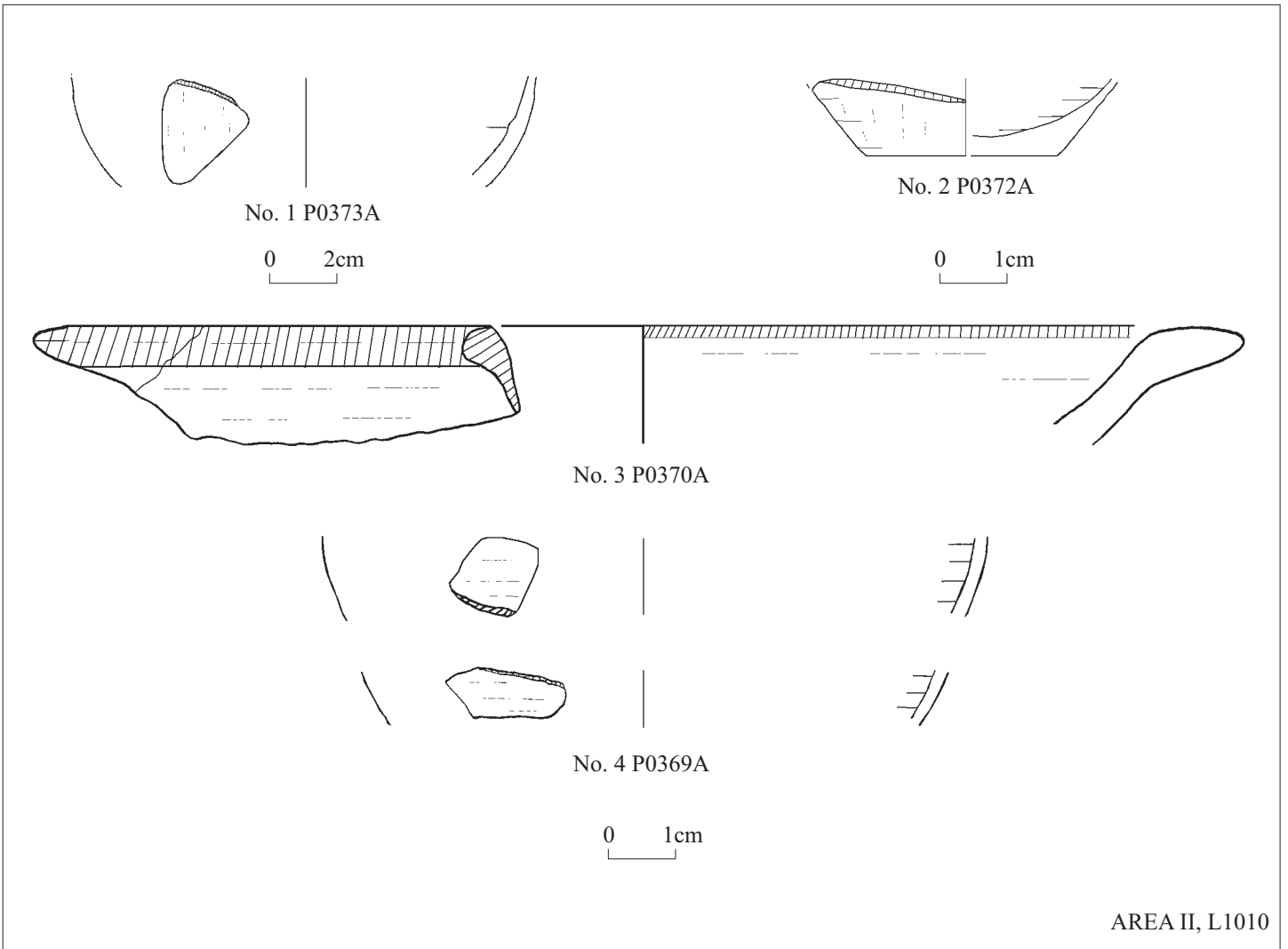


Fig. 39

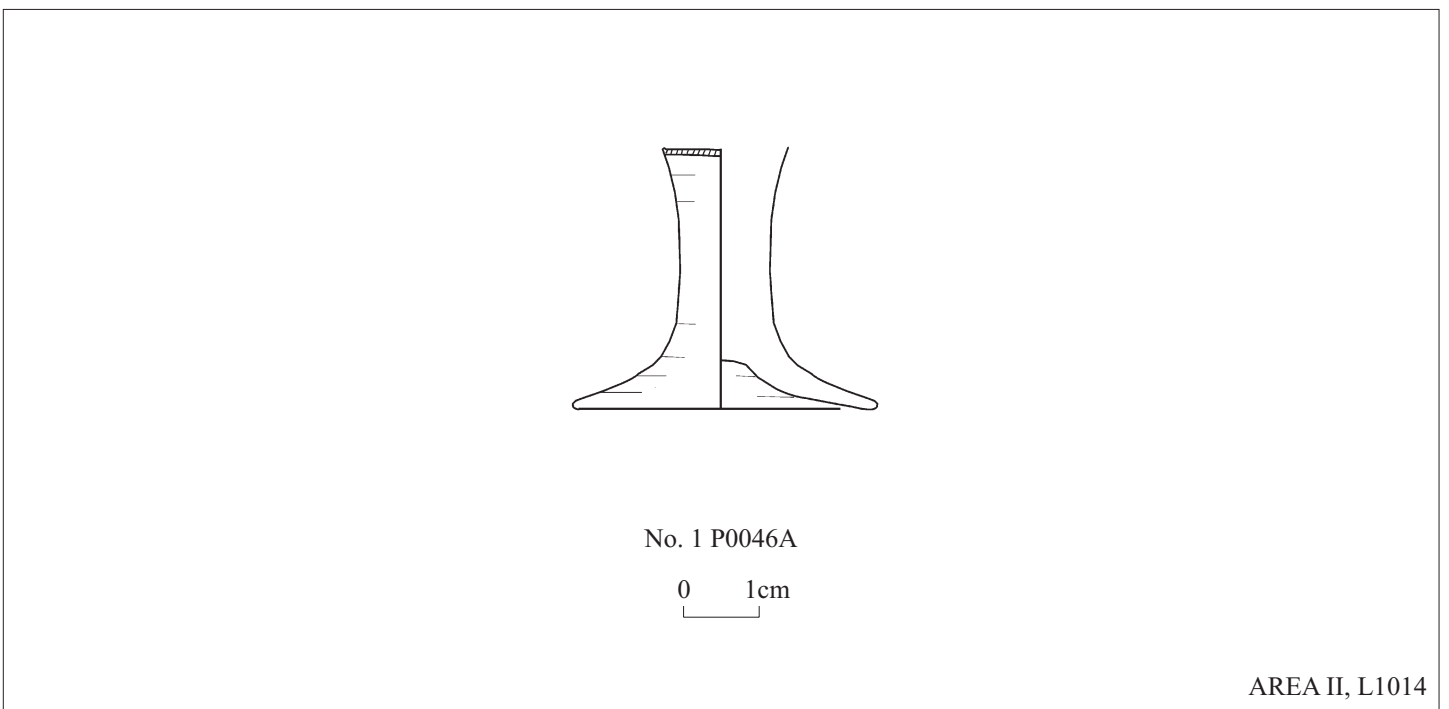


Fig. 40

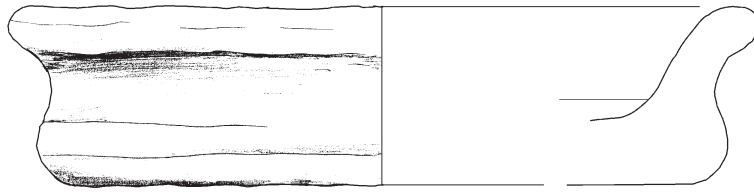


No. 1 P2002A

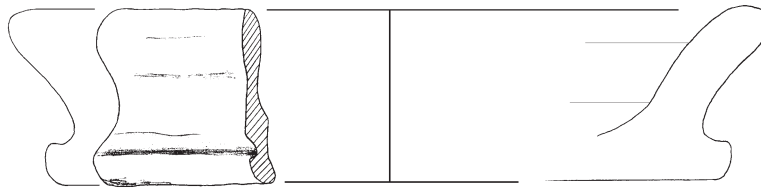
0 1cm

AREA II, L1016

Fig. 41



No. 1 P1059A



No. 2 P1060A

0 2cm

AREA II, L1031

Fig. 42

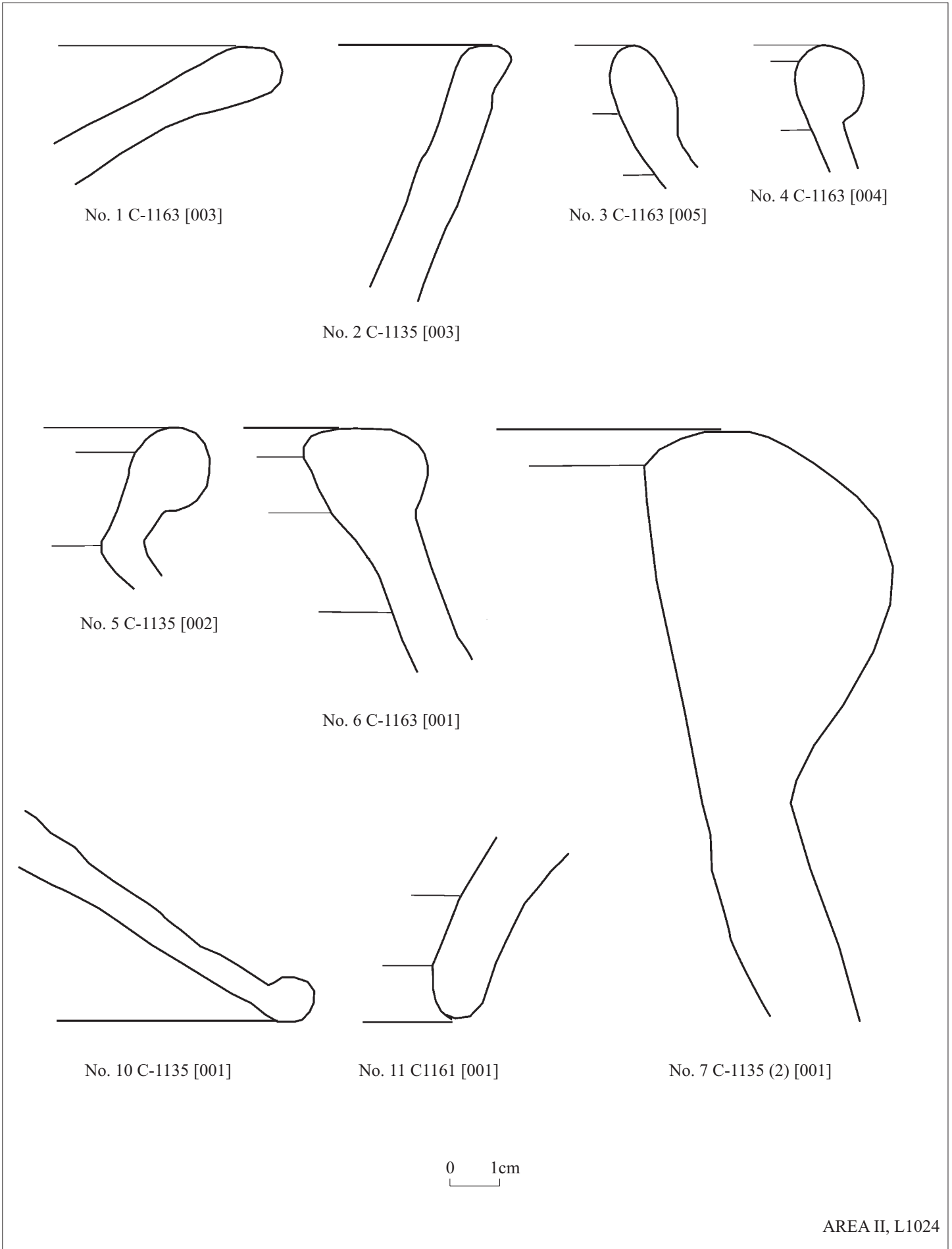
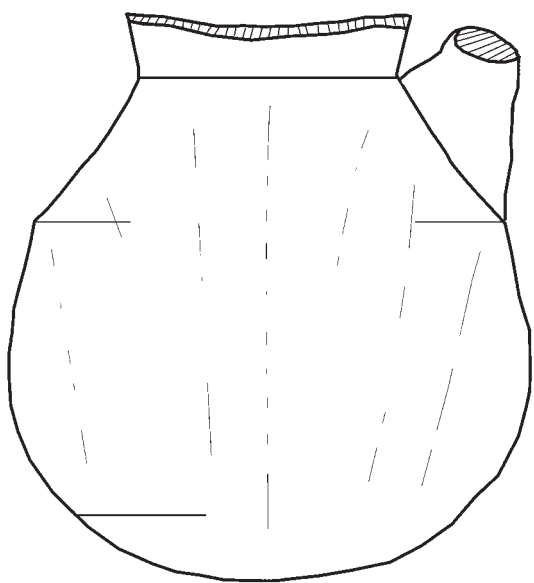
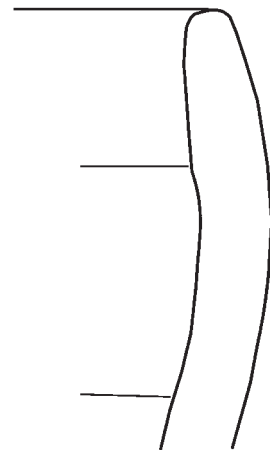
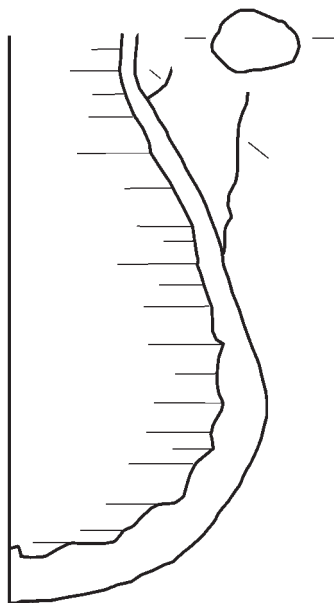


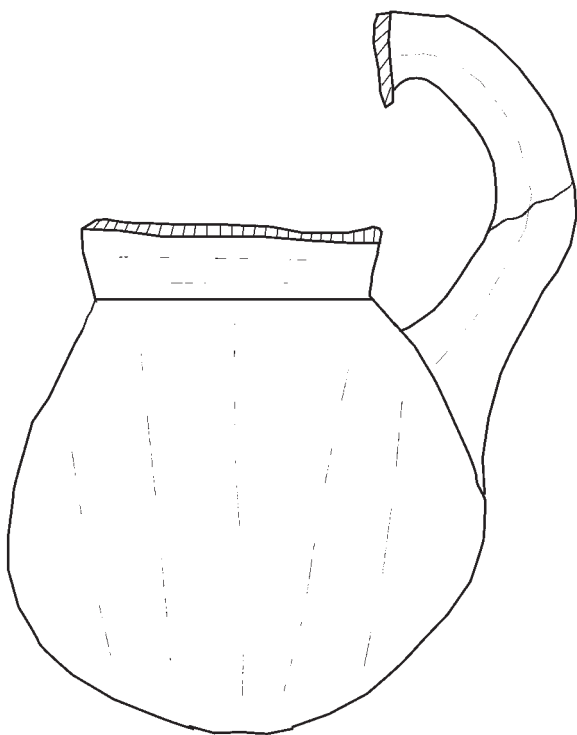
Fig. 43



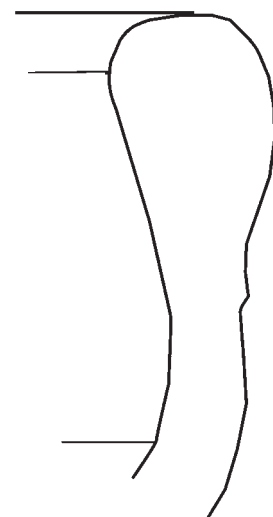
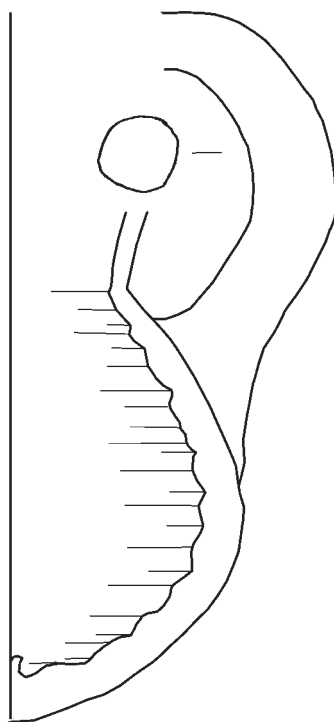
No. 1 P0003A



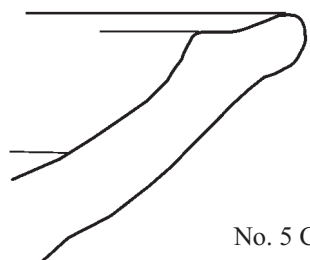
No. 3 C-1108 [004]



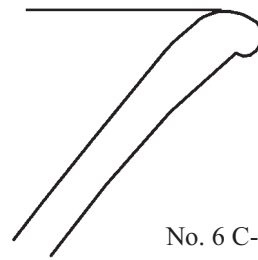
No. 2 P0002A



No. 4 C-1143 [002]



No. 5 C-1143 [005]

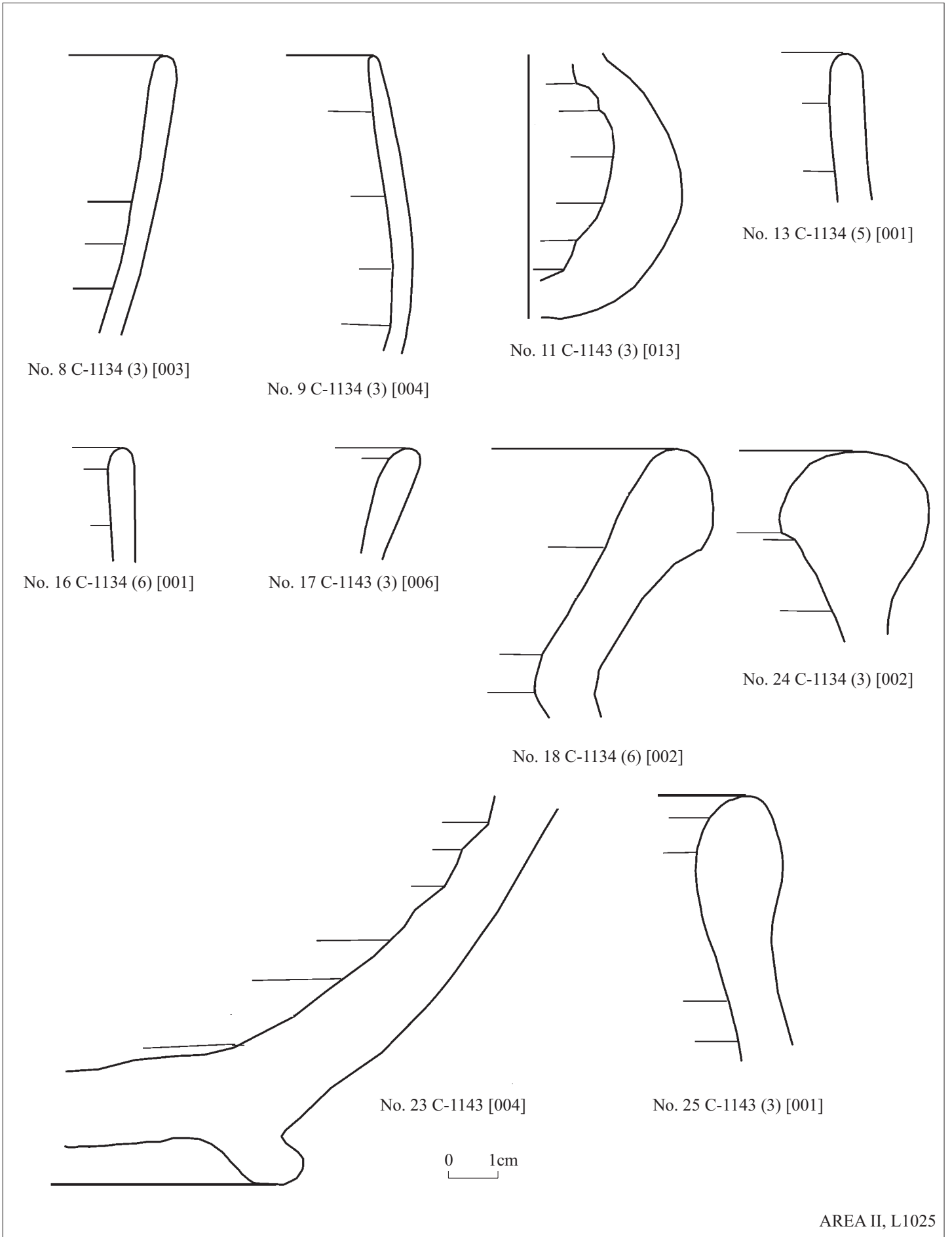


No. 6 C-1134 [002]



AREA II, L1025

Fig. 44:1



AREA II, L1025

Fig. 44:2

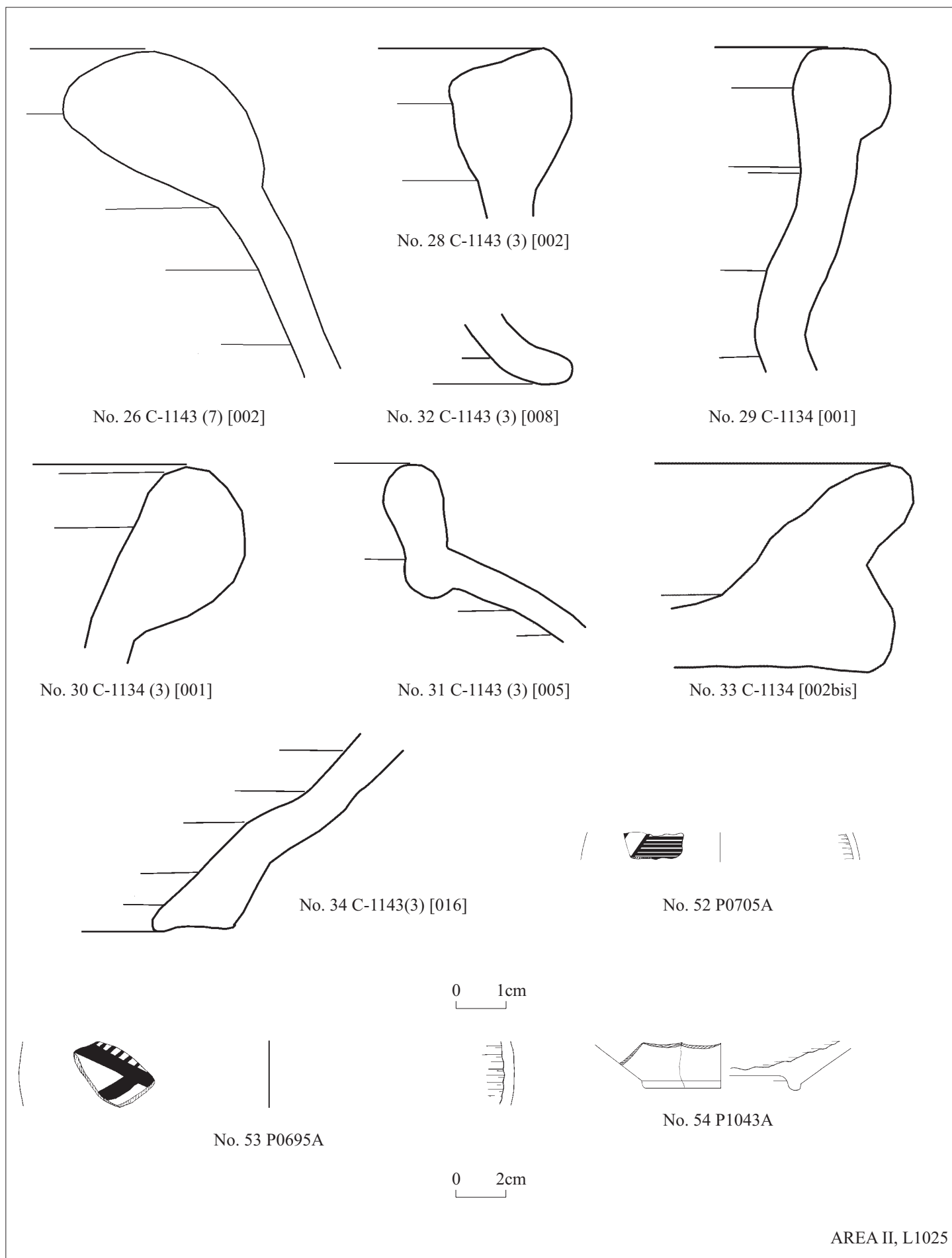


Fig. 44:3



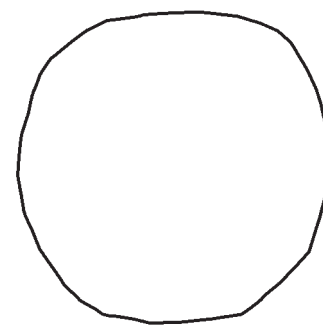
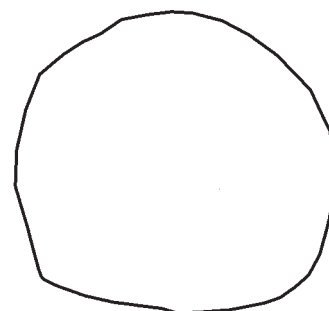
No. 58 P0707A



No. 59 P0694A



No. 60 P0708A



No. 61 F0228A



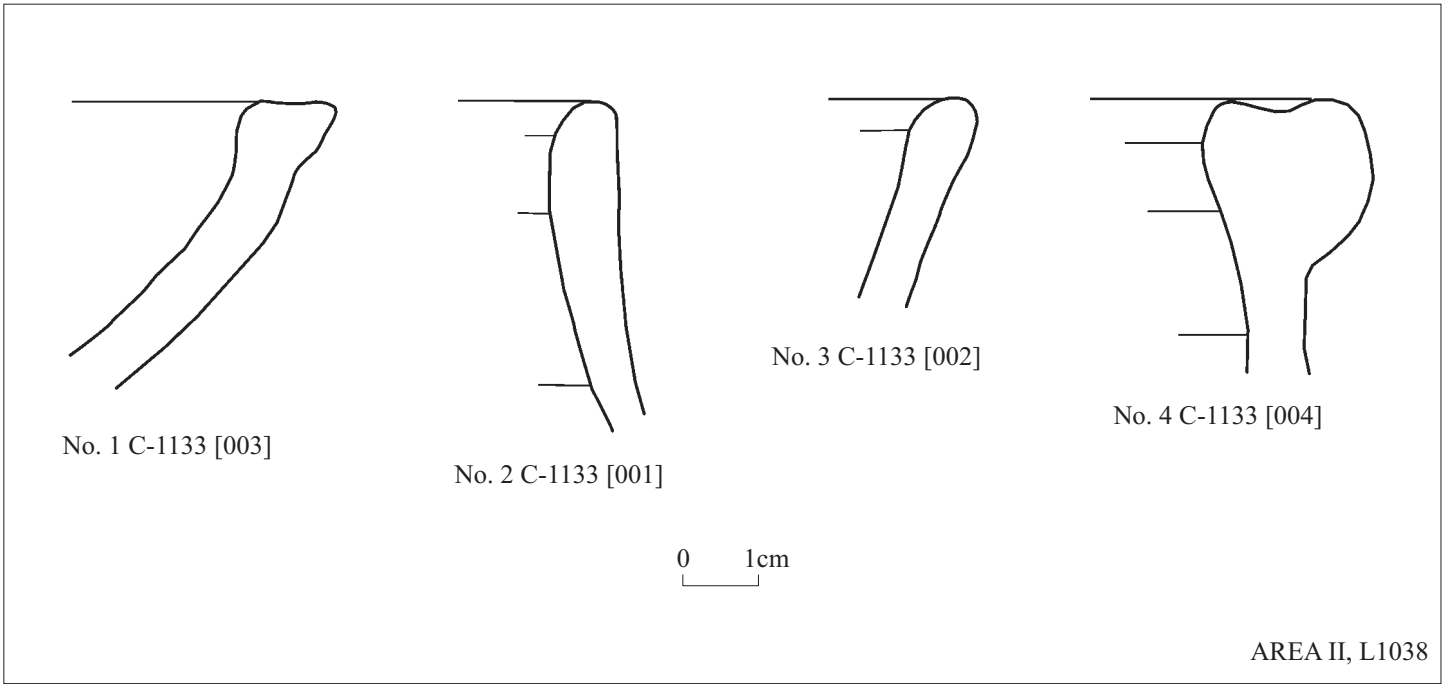


Fig. 45

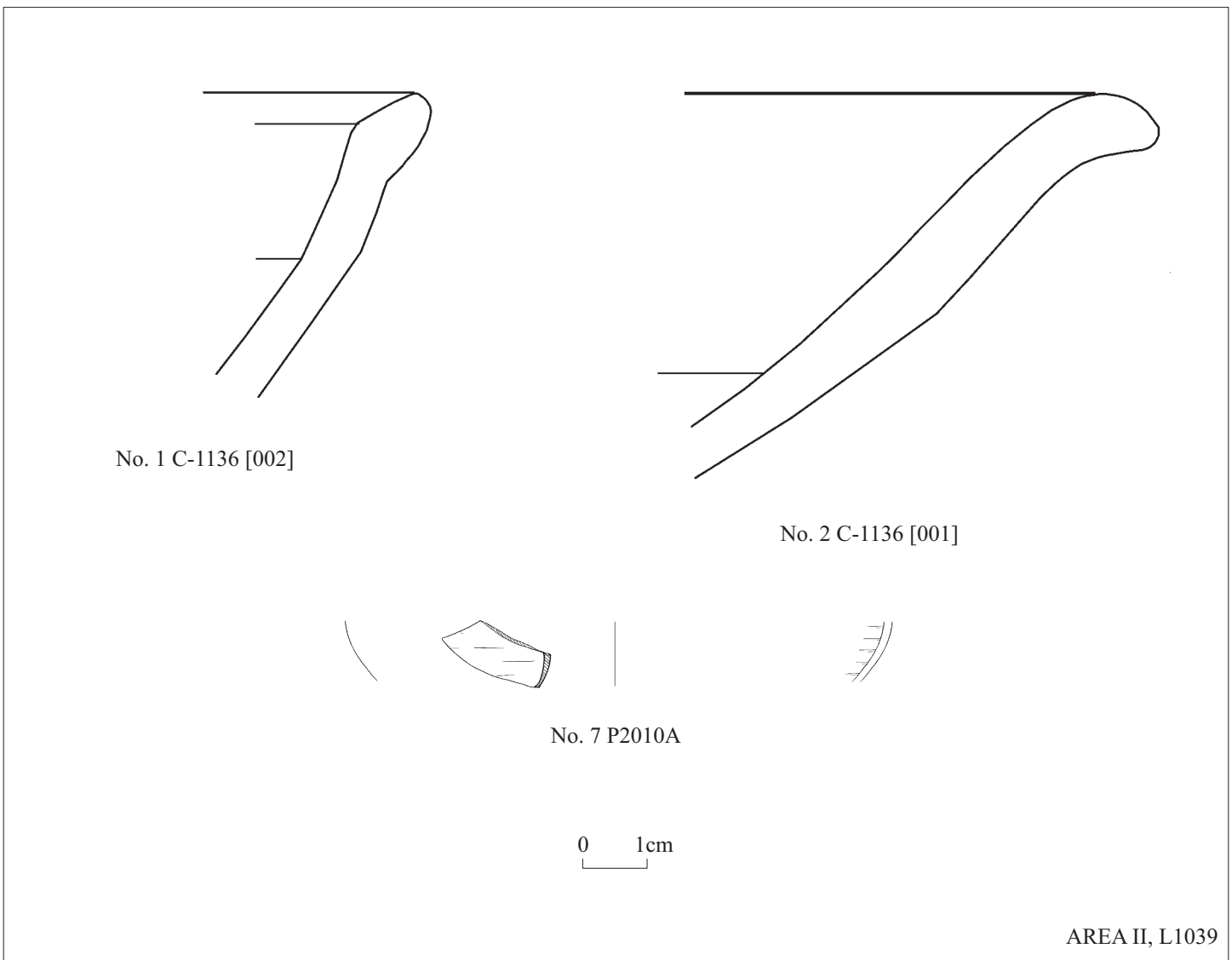


Fig. 46

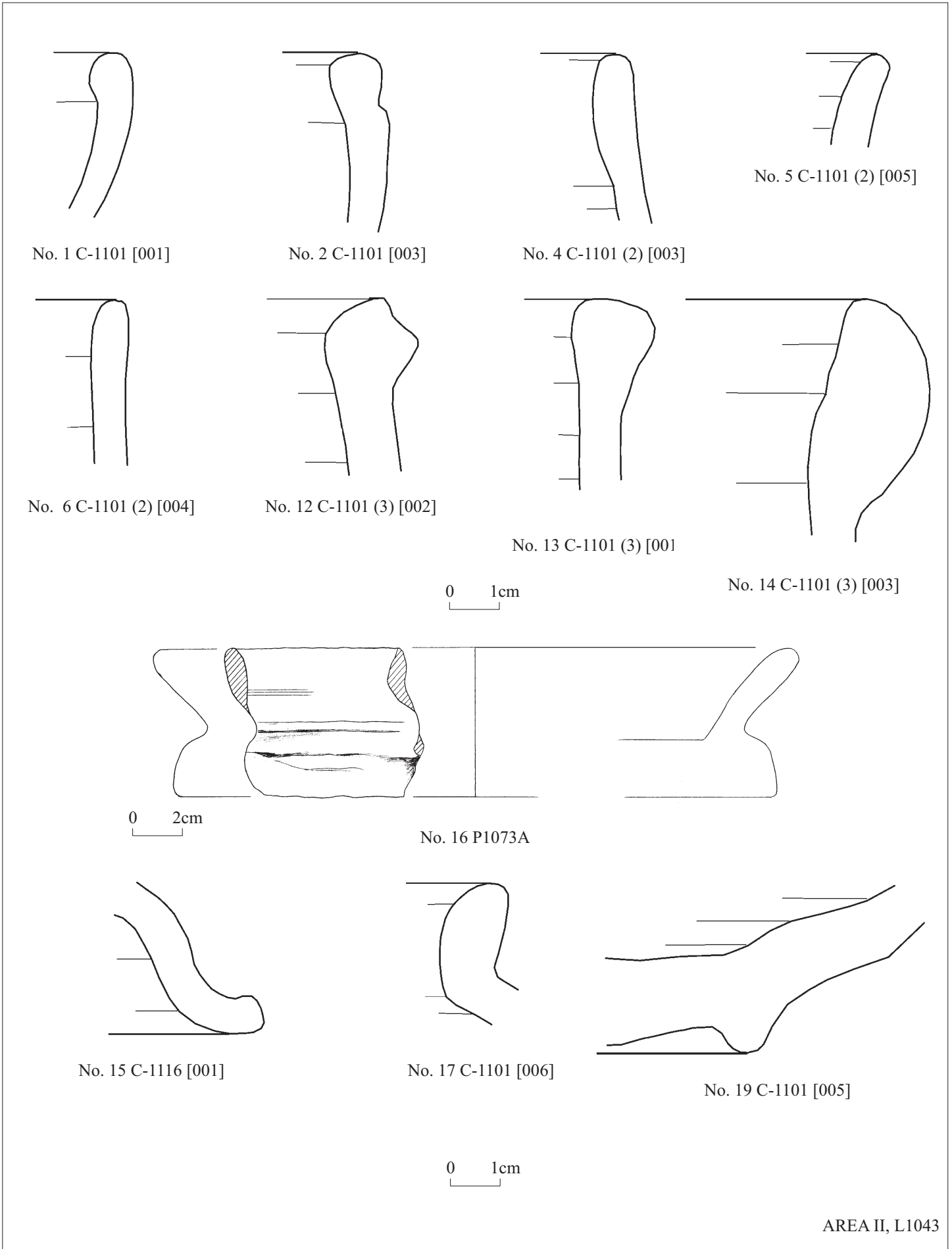
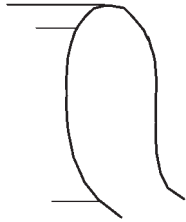
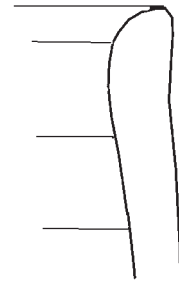


Fig. 47:1



No. 20 C-1101 (3) [004]



No. 24 C-1101 [002]

0 1cm

AREA II, L1043

Fig. 47:2



No. 27 F0251

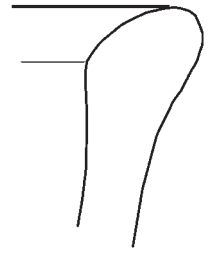
AREA II, L1043



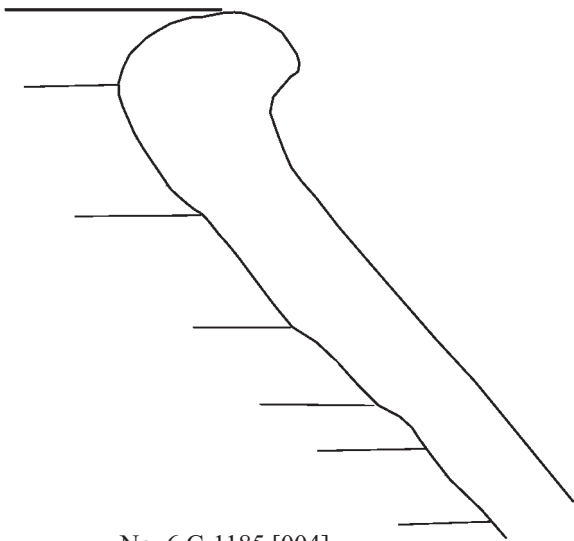
No. 1 C-1185 [007]



No. 2 C-1150 [004]



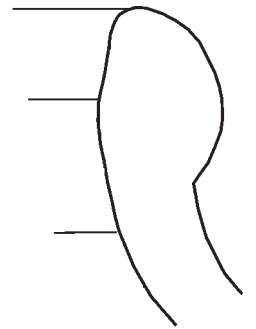
No. 3 C-1150 [003]



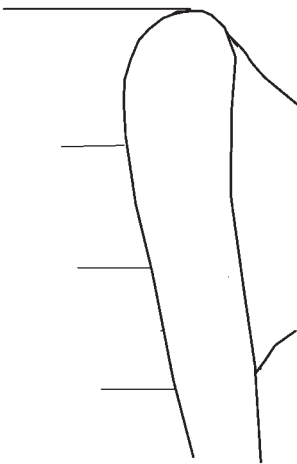
No. 6 C-1185 [004]



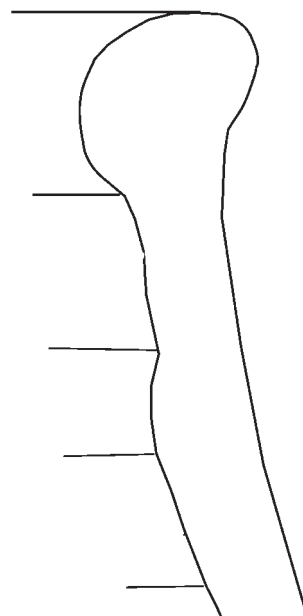
No. 7 C-1185 [001]



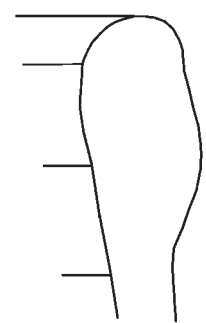
No. 8 C-1160 [009]



No. 13 C-1150 [006]



No. 14 C-1160 [008]



No. 15 C-1185 [003]

0 1cm

Fig. 48:1

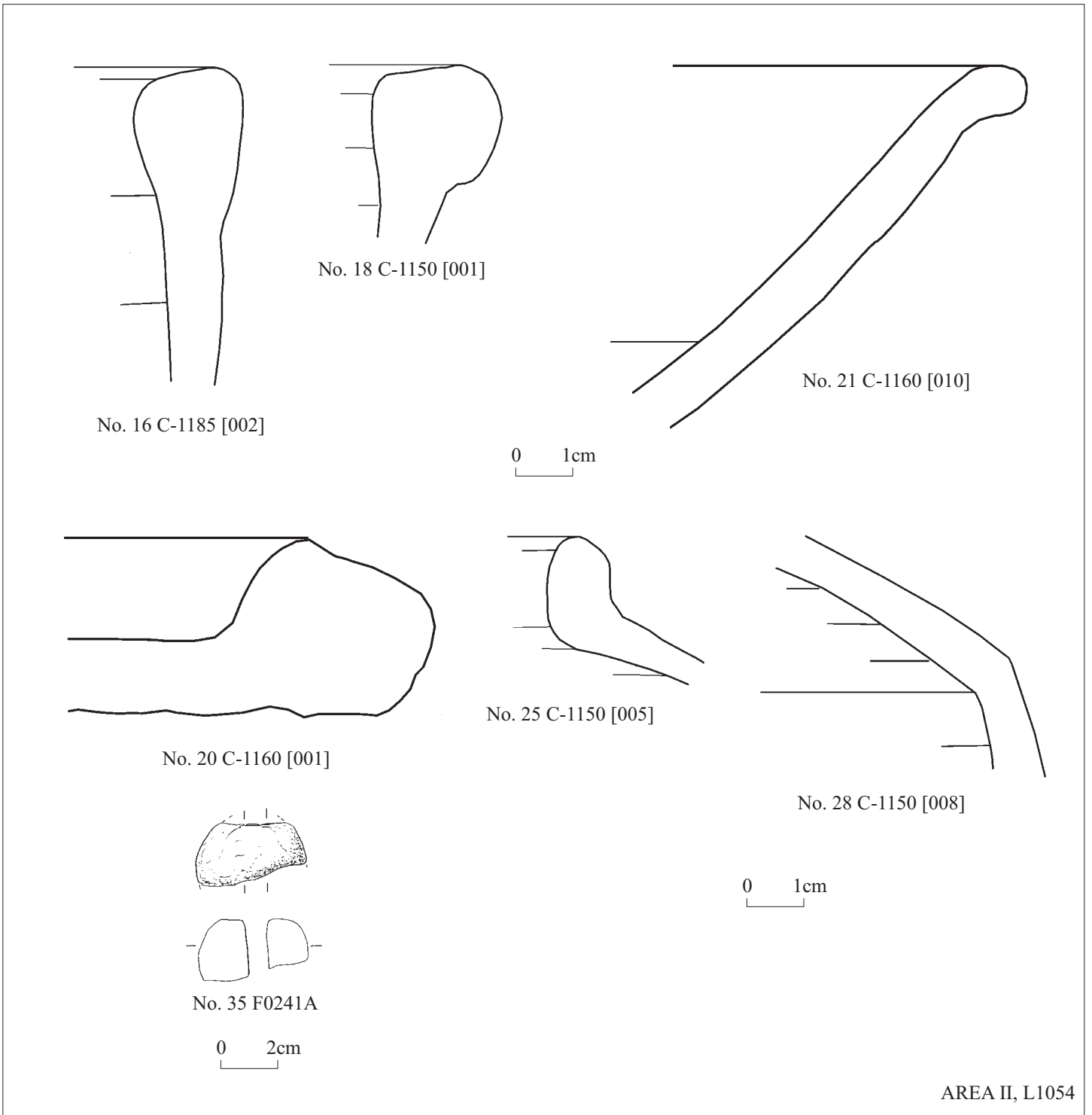


Fig. 48:2

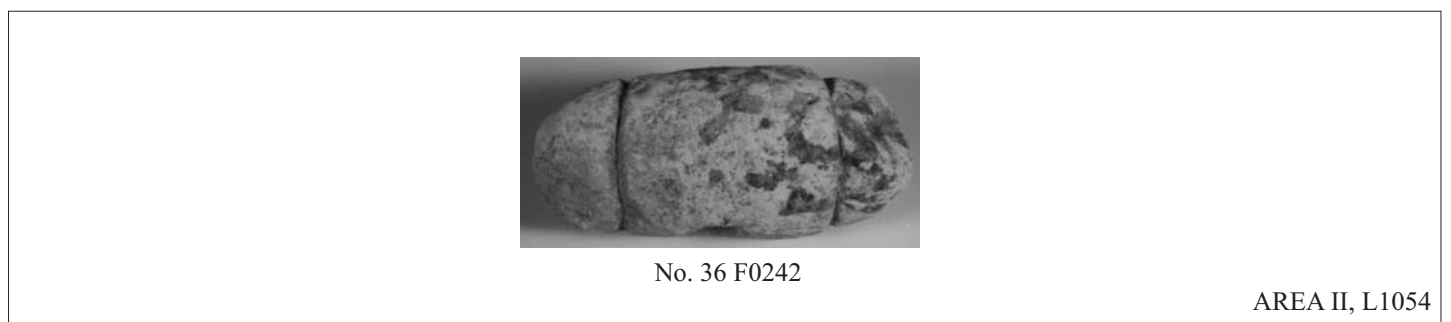
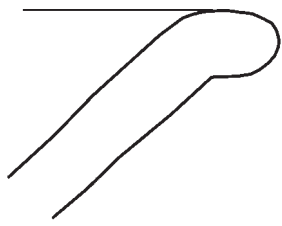


Plate 3



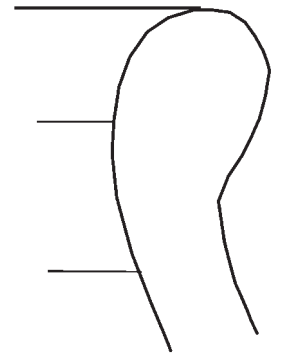
No. 1 C-1183 [001]



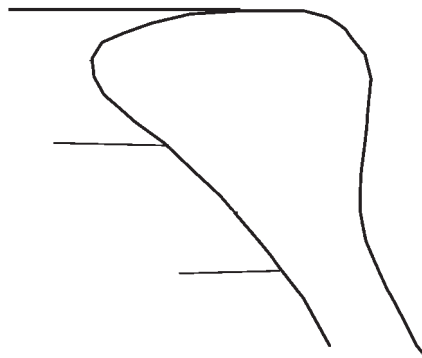
No. 2 C-1183 [002]



No. 3 C-1183 [004]

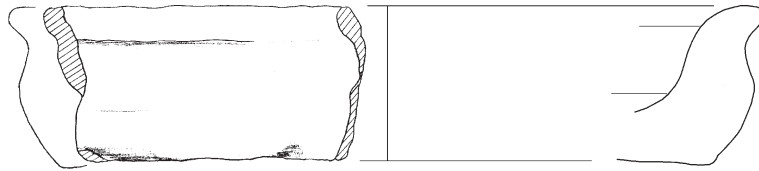


No. 6 C-1183 [005]

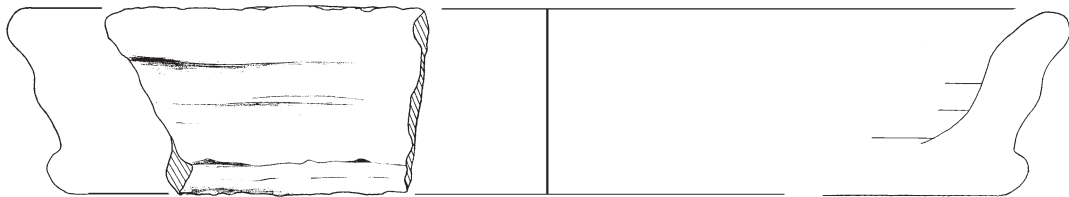


No. 7 C-1183 [006]

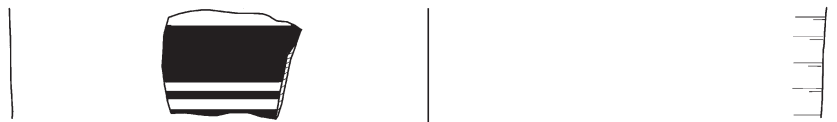
0 1cm



No. 8 P1080A



No. 9 P1087A

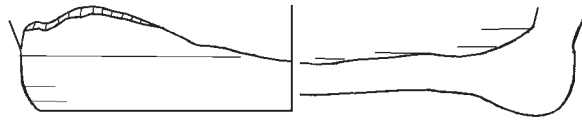


No. 12 P0780A

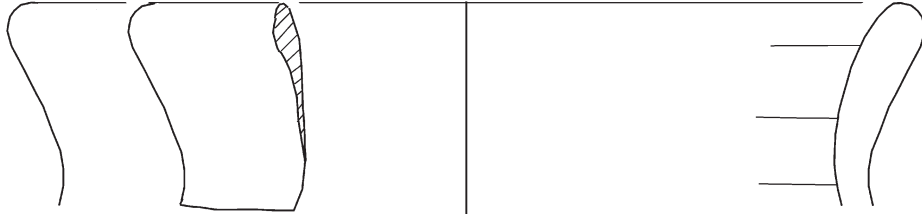
0 2cm

AREA II, L1060

Fig. 49:1



No. 13 P1280A

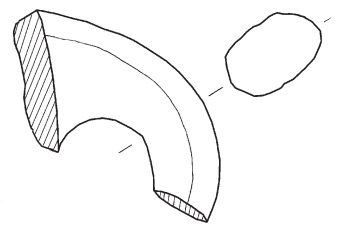
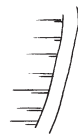


No. 14 P2036A

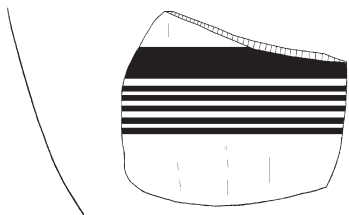
0 1cm



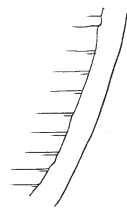
No. 17 P0781A



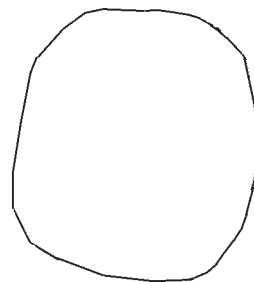
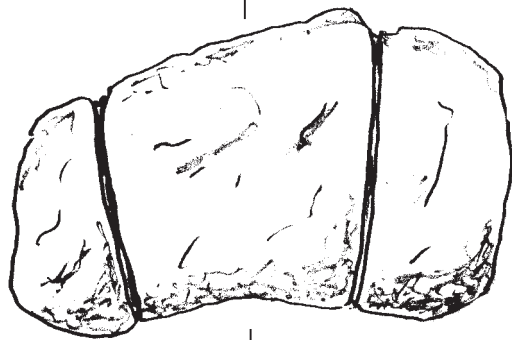
No. 20 P1277A



No. 18 P700A



0 2cm



No. 21 F0183A

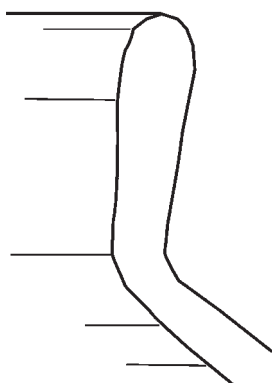
0 1cm

AREA II, L1060

Fig. 49:2



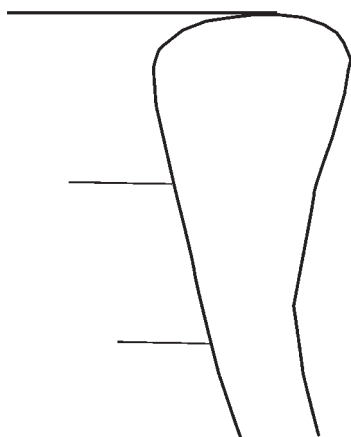
No. 1 C-1217 (2) [003]



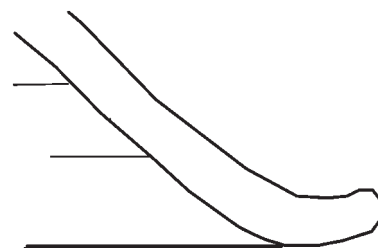
No. 2 C-1217 (2) [001]



No. 3 C-1217 (2) [002]



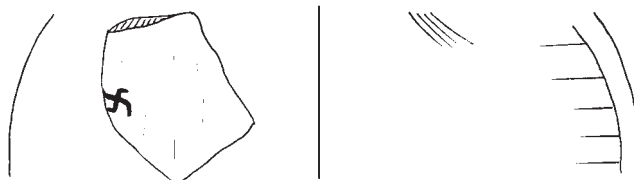
No. 5 C-1217 (2) [007]



No. 6 C-1217 (2) [006]



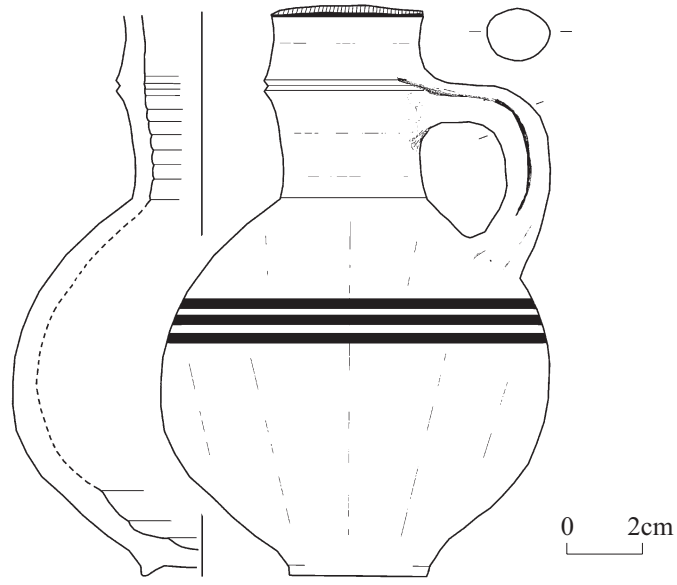
No. 13 P0698A



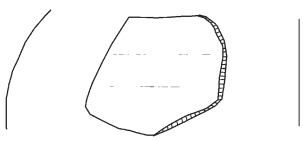
No. 14 P0696A

0 1cm

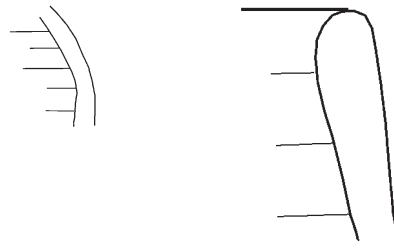
Fig. 50



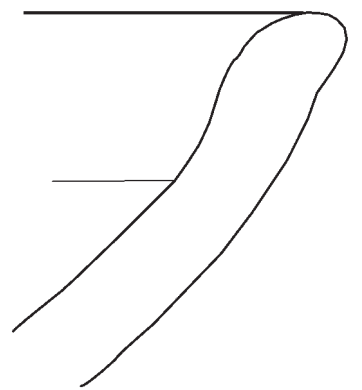
No. 1 P0001



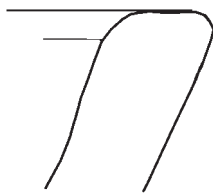
No. 2 P0766A



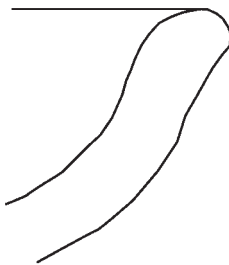
No. 3 C1214 (2bis) [006]



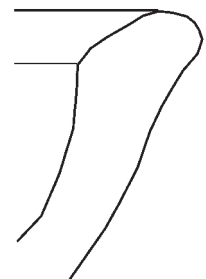
No. 5 C-1112[016]



No. 6 C-1112[019]



No. 8 C-1112 [008]



No. 9 C-1112 [006]



Fig. 51:1

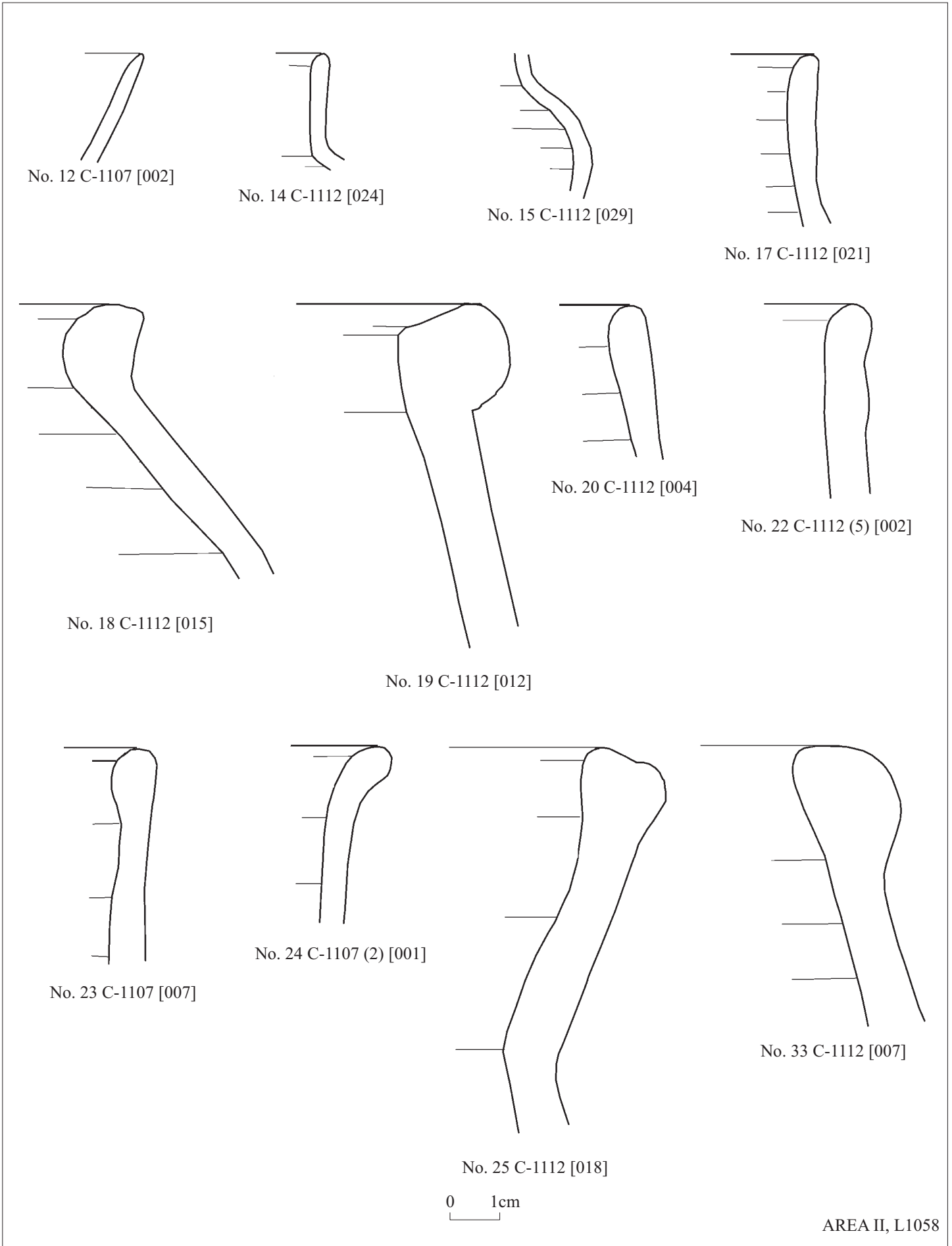
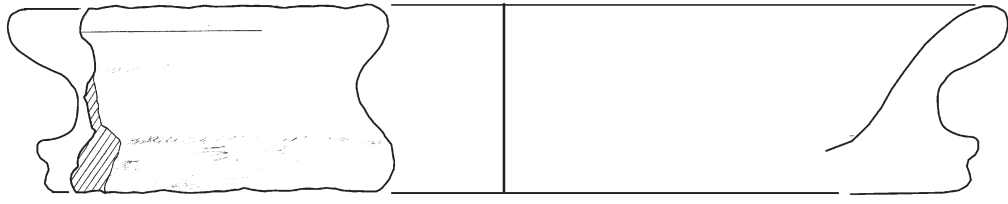
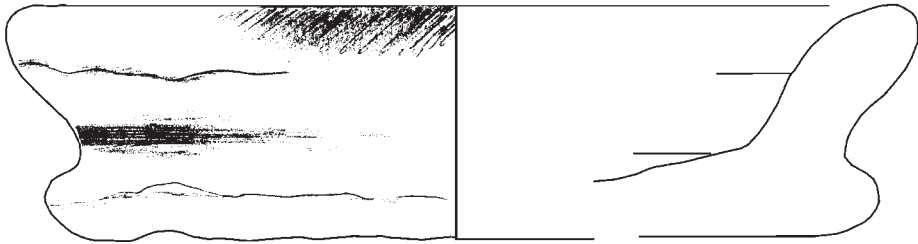


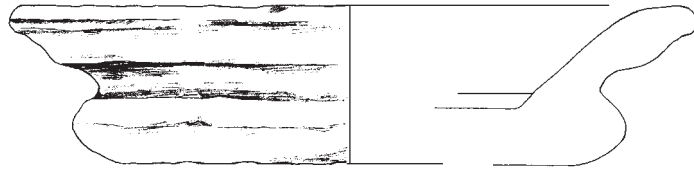
Fig. 51:2



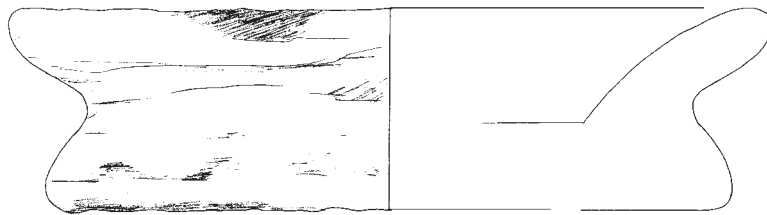
No. 38 P1029A



No. 39 P1027A



No. 40 P1079A



No. 41 P1028A

0 2cm

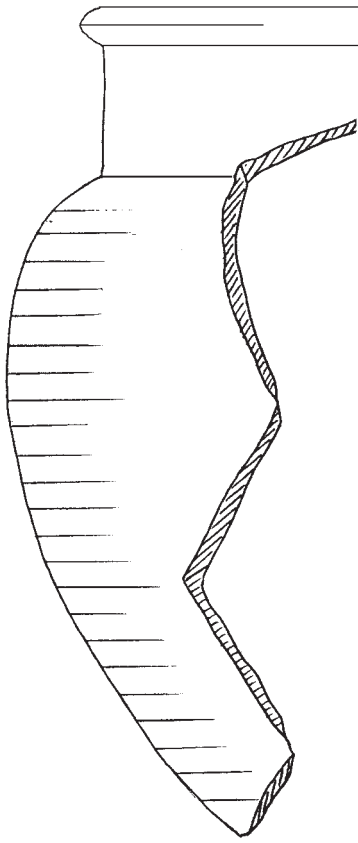


No. 43 C-9067 [001]

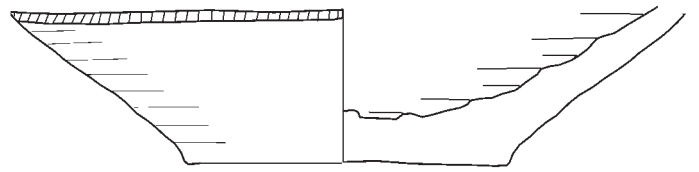
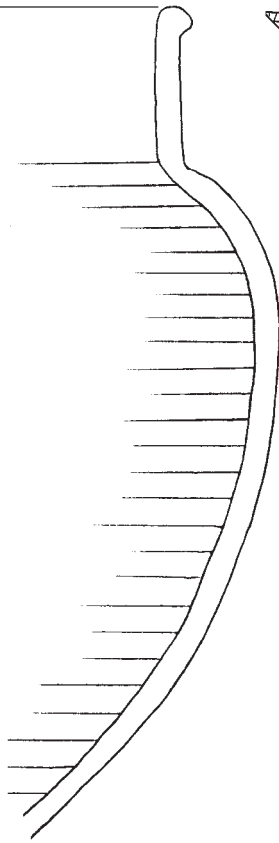


No. 44 C-1112 (5) [009]

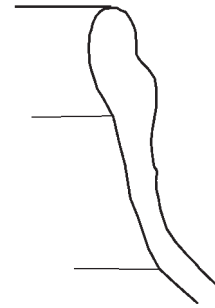
0 1cm



No. 45 P0742A

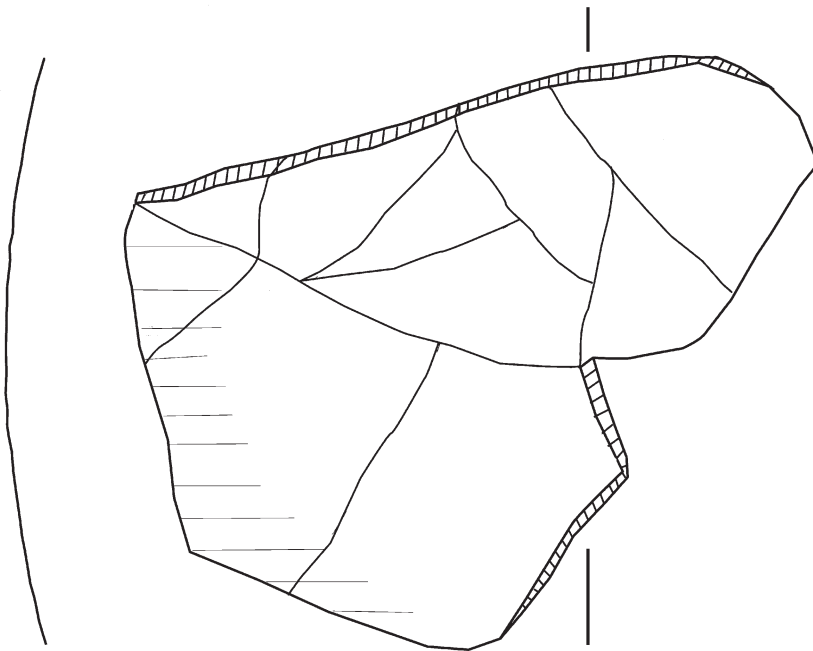


No. 46 P0743A



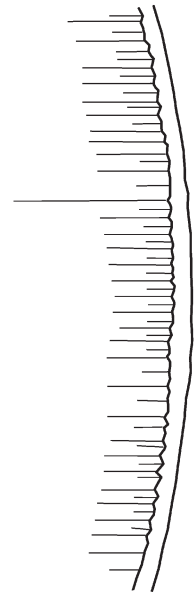
No. 47 C-1112 (7) [001]

0 1cm



No. 51 P1120A

0 2cm



AREA II, L1058

Fig. 51:4

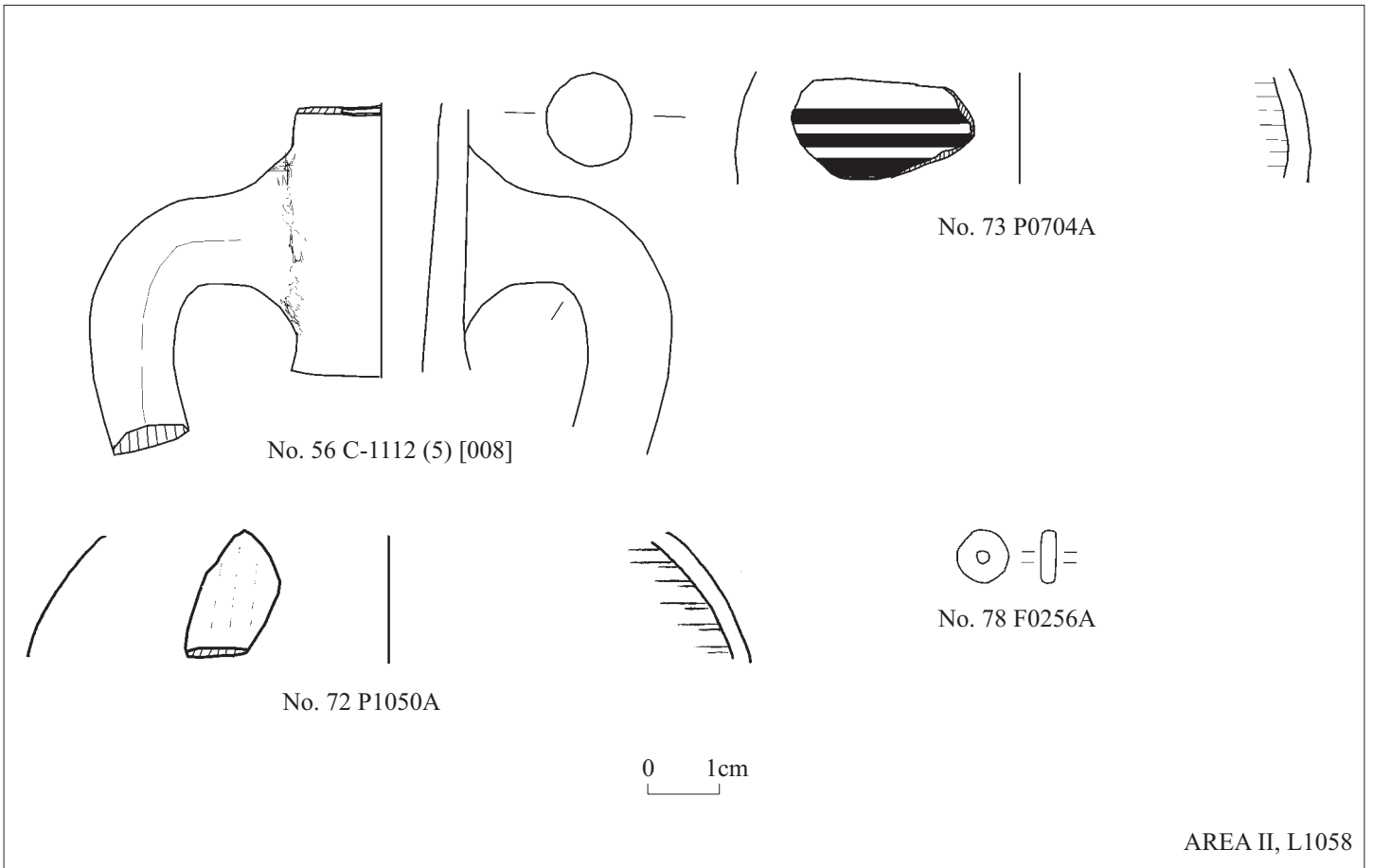


Fig. 51:5



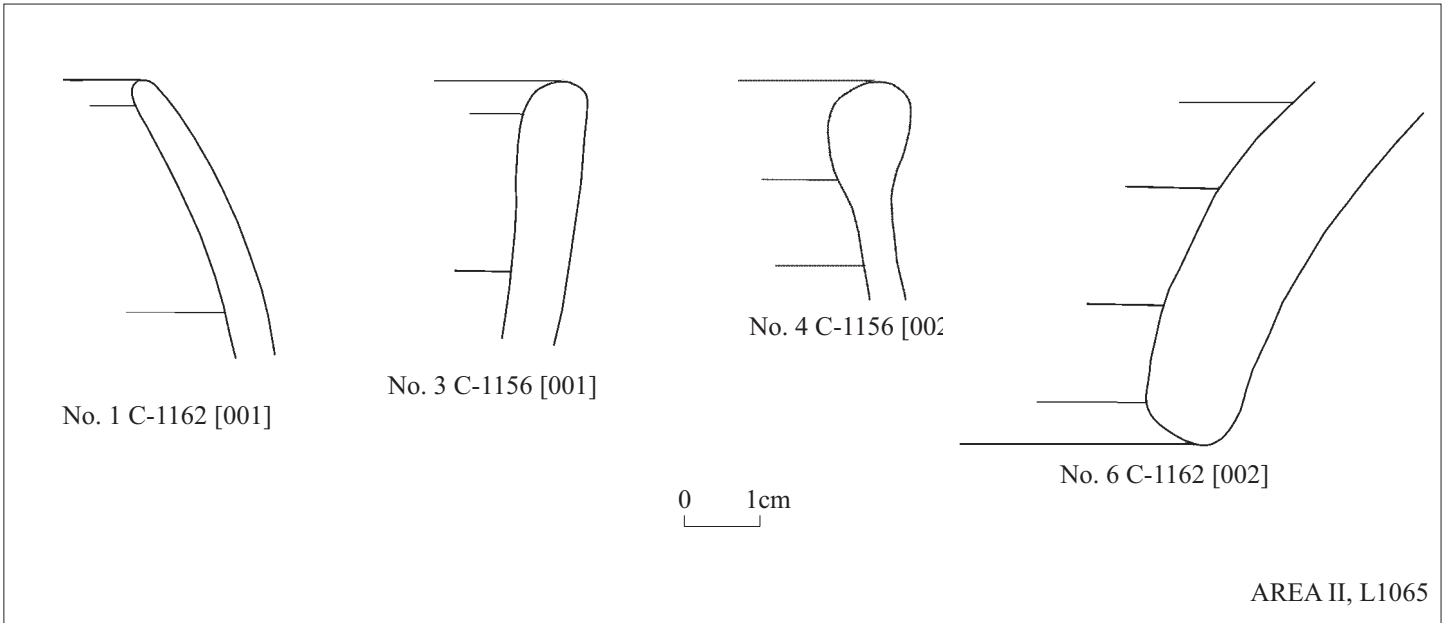


Fig. 52

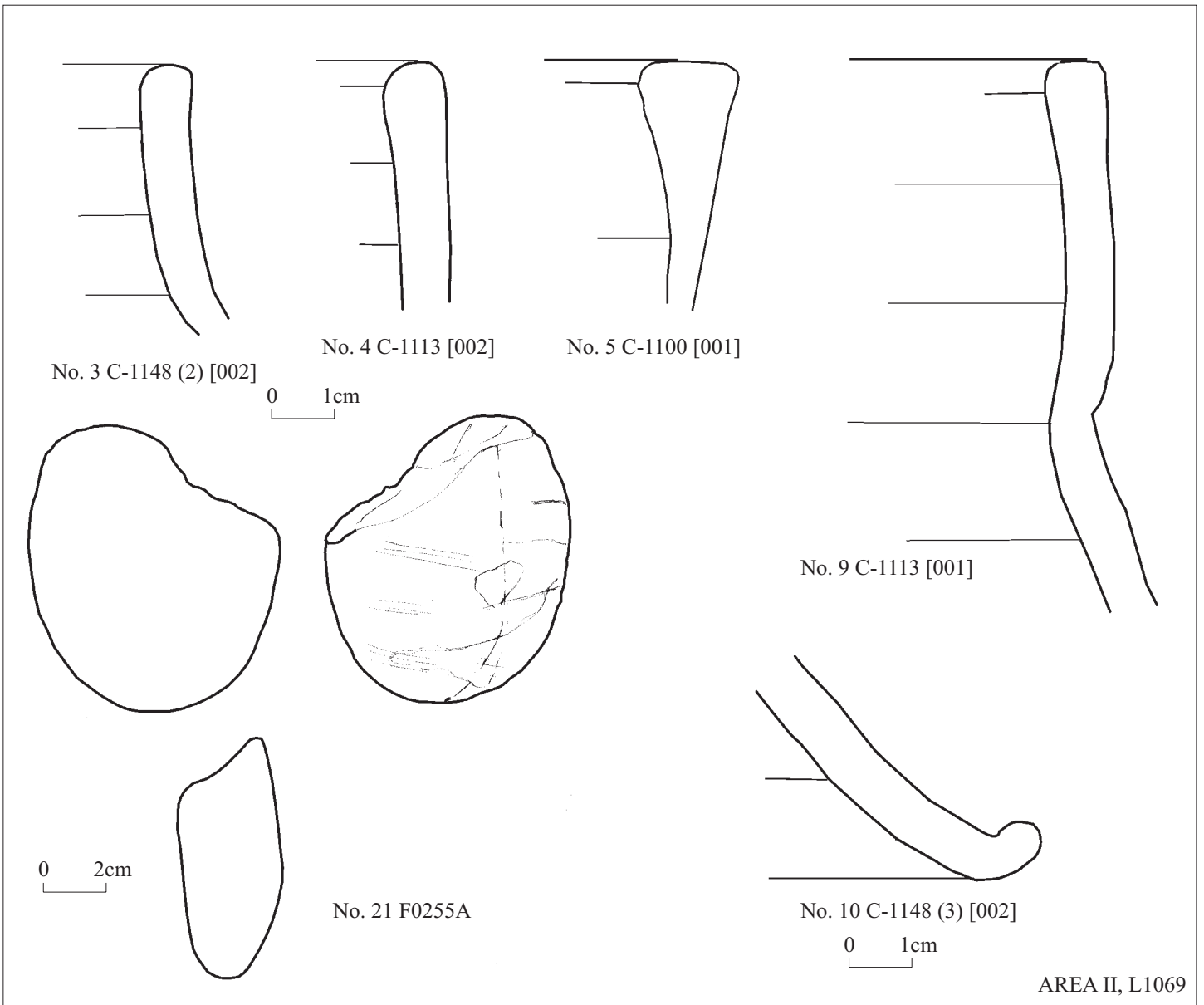
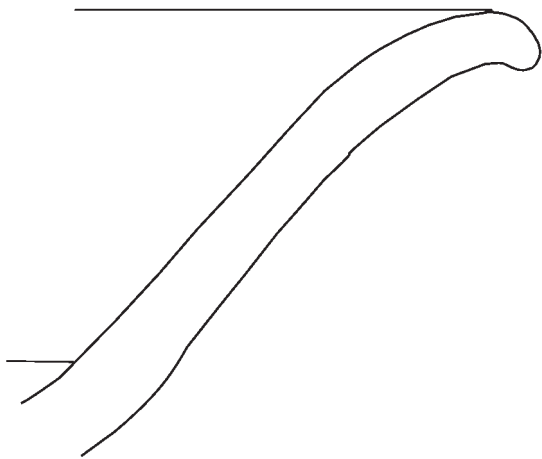
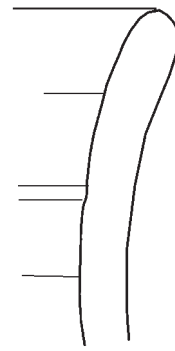


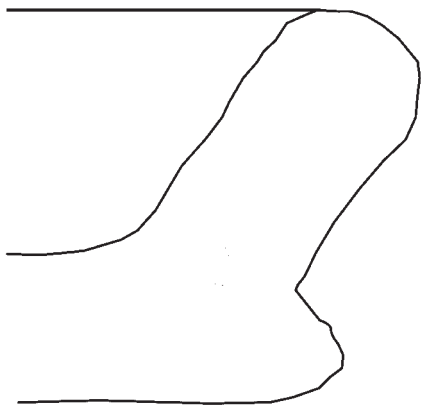
Fig. 53



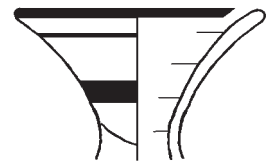
No. 1 C-1216 [001]



No. 5 C-1216 [002]

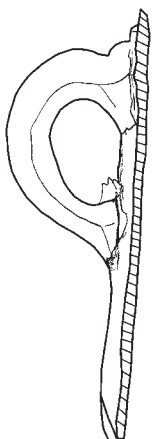


No. 9 C-9077 [001]



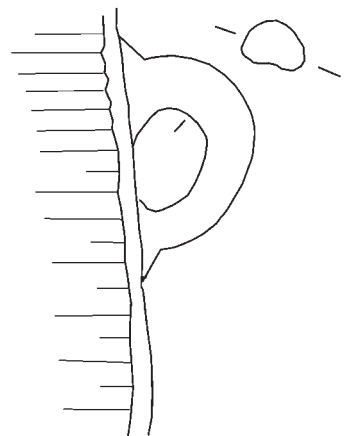
No. 17 P2039A

0 1cm



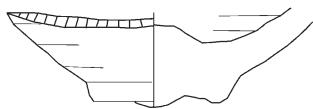
No. 11 P1121A

0 2cm



AREA II, L1084

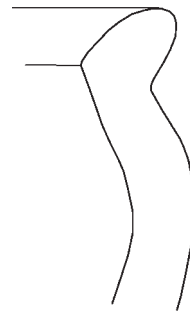
Fig. 54



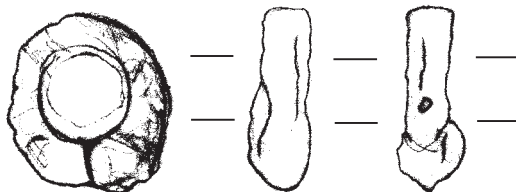
No. 1 P7018A



No. 2 C-1152 [002]



No. 3 C-1152 [001]



No. 4 F0277

0 1cm

AREA II, L1090

Fig. 55



No. 1 F0274

AREA II, L1091

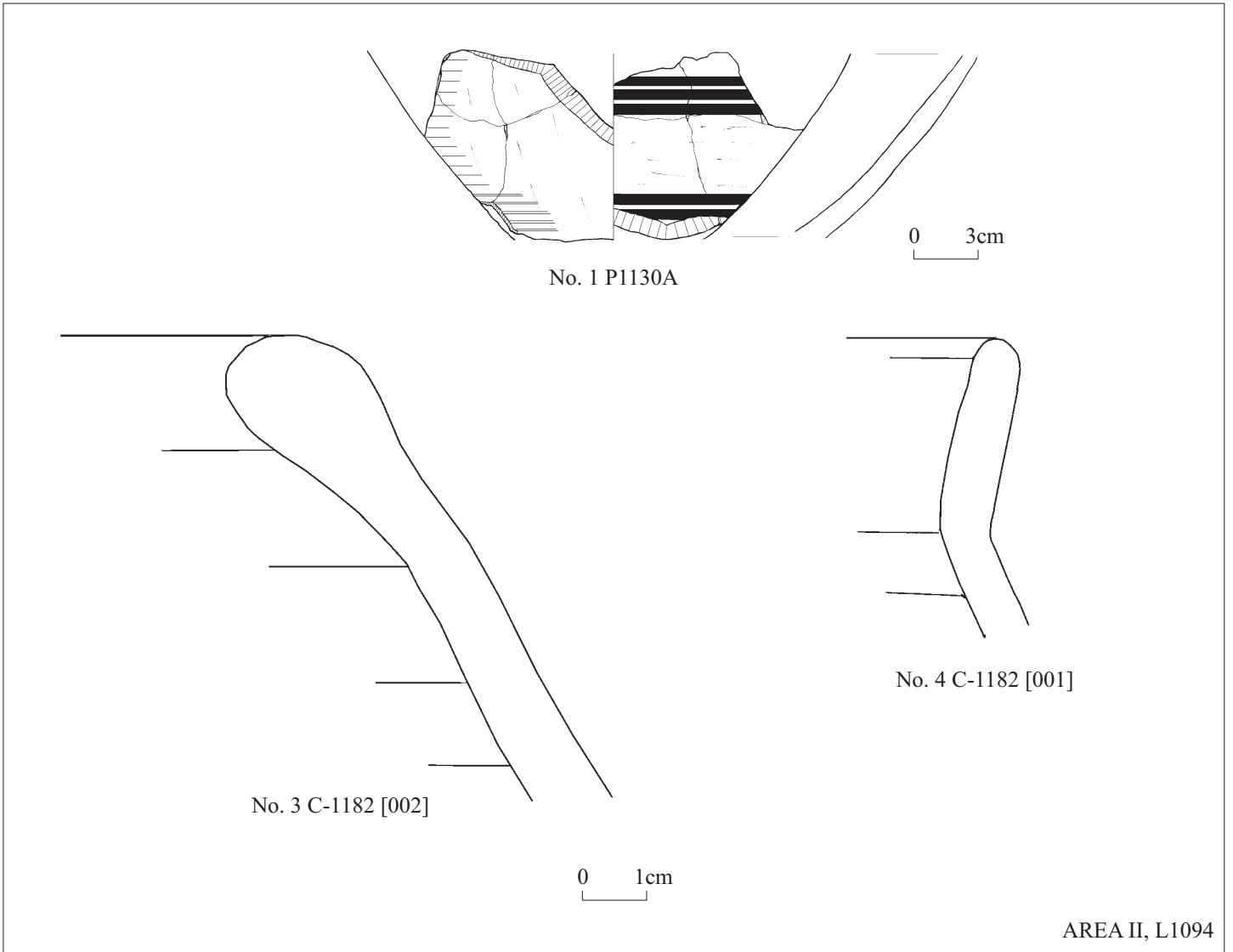


Fig. 56

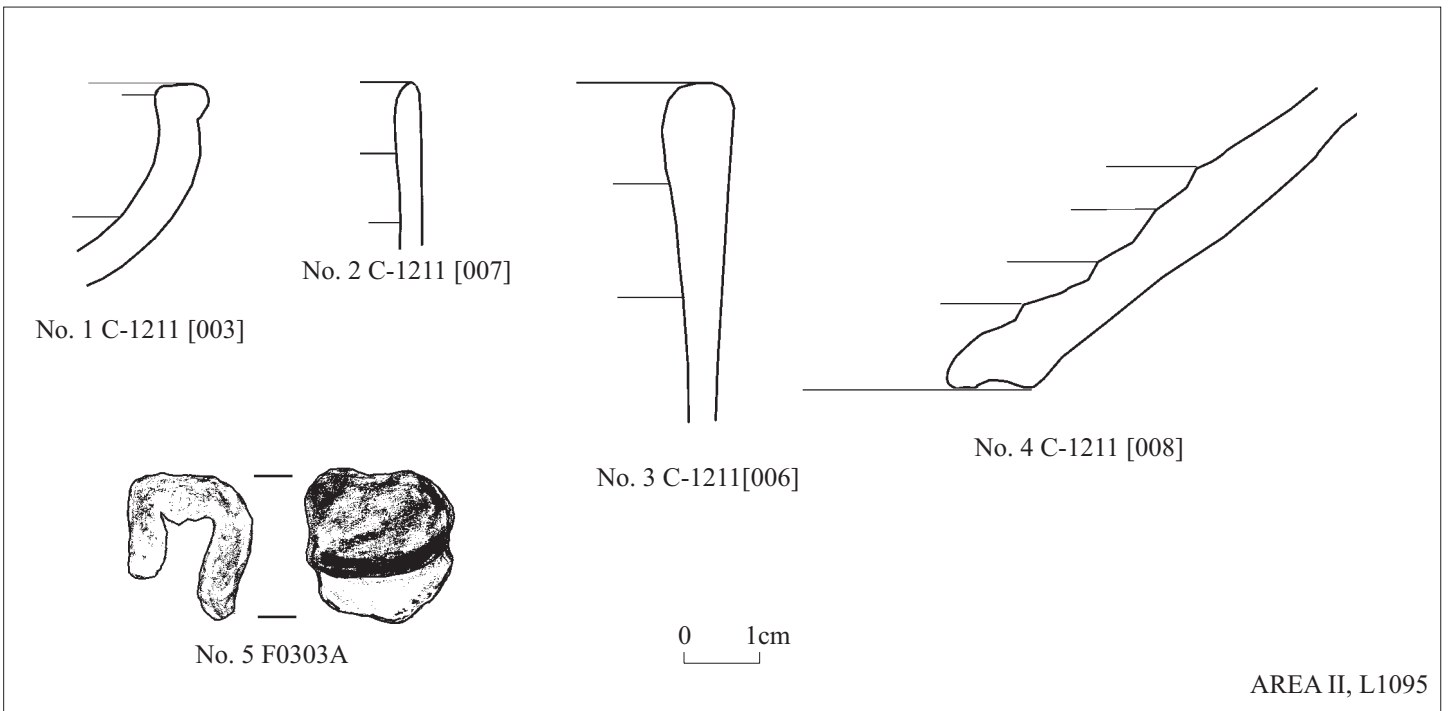
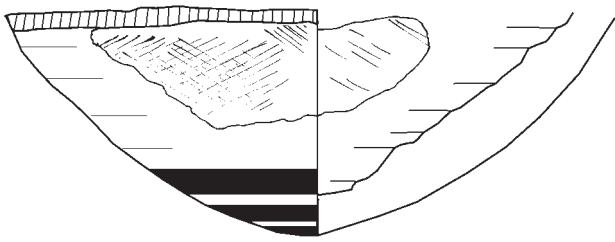


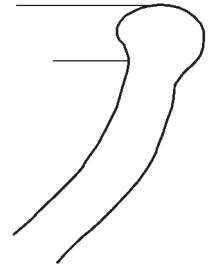
Fig. 57



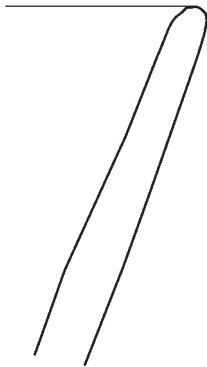
No. 2 P1164A



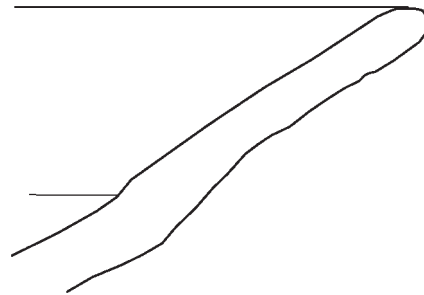
No. 3 C-1007 [003]



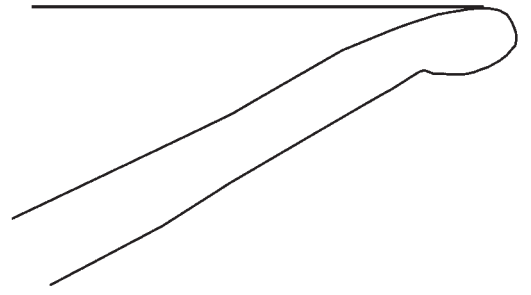
No. 4 C-1002 [003]



No. 5 C-1192 [001]



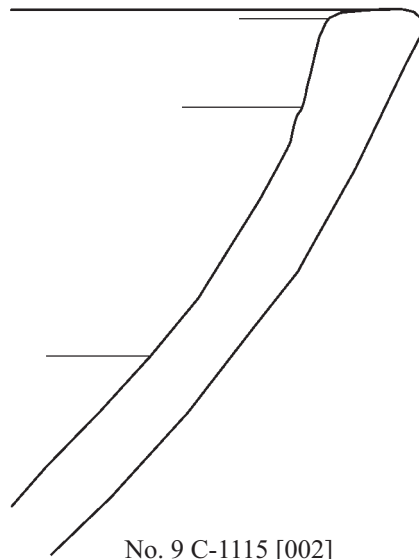
No. 6 C-1158 [005]



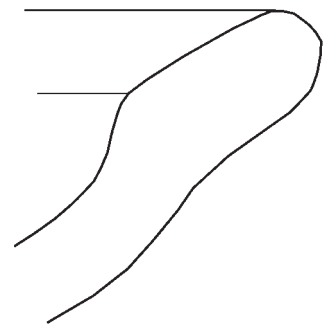
No. 7 C-1115 [038]



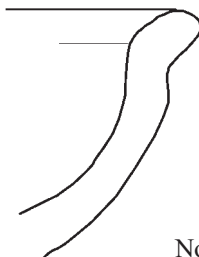
No. 8 C-1104 [021]



No. 9 C-1115 [002]



No. 10 C-1172 [005]



No. 11 C-1172 [036]

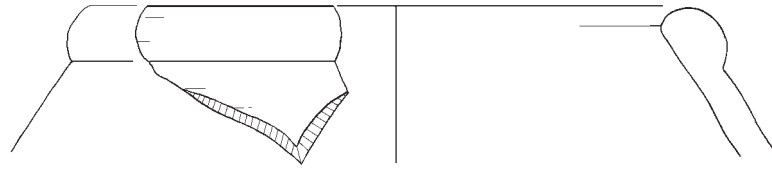


No. 14 C-1104 [014]



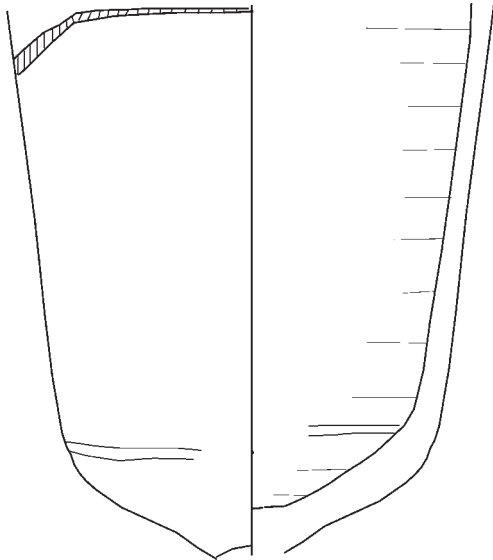
AREA II, L1001=L1004

Fig. 58:1

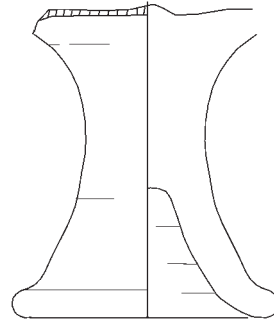


No. 15 P7025A

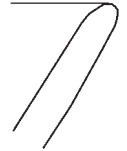
0 2cm



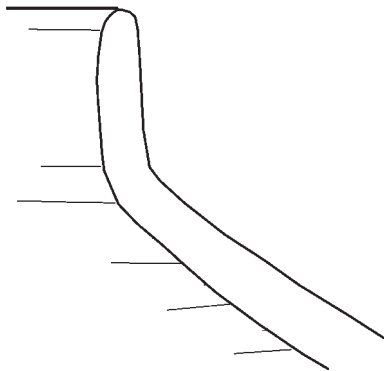
No. 16 P7026A



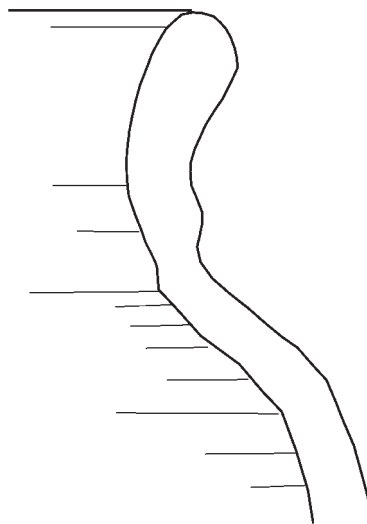
No. 17 P0212A



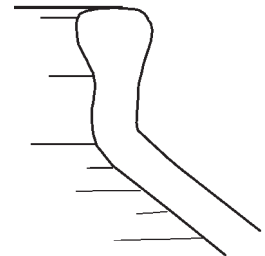
No. 18 C-1171 [003]



No. 21 C-1104 [020]



No. 22 C-1104 (2) [002]

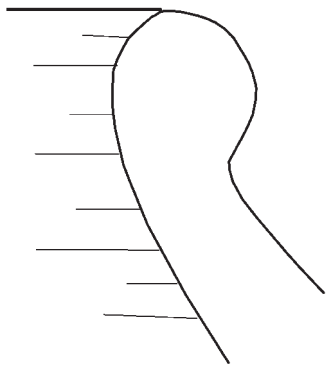


No. 23 C-1115 [014]

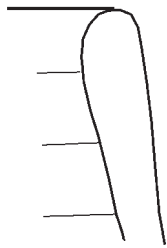
0 1cm

AREA II, L1001=L1004

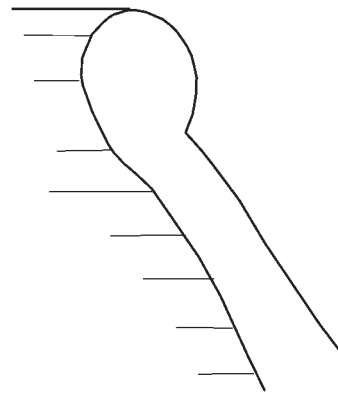
Fig. 58:2



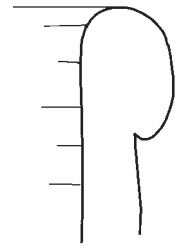
No. 24 C-1172 [015]



No. 25 C-1104 [002]



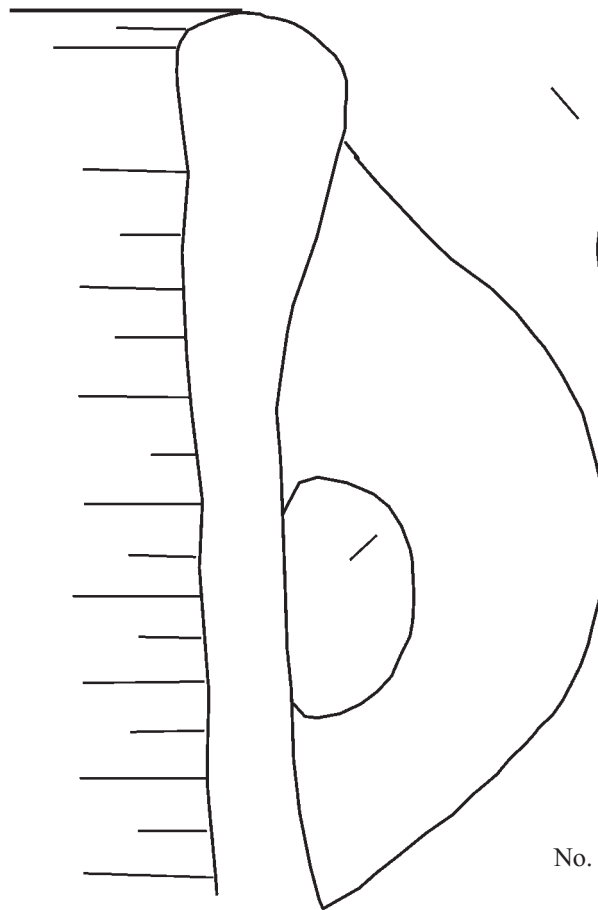
No. 26 C-1104 [019]



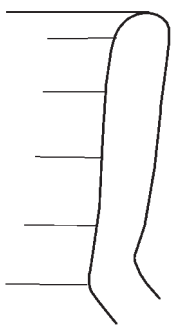
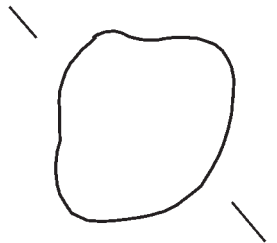
No. 27 C-1007 [002]



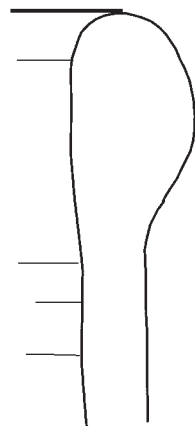
No. 28 C-1172 [008]



No. 29 C-1115 [034]



No. 30 C-1190 [006]

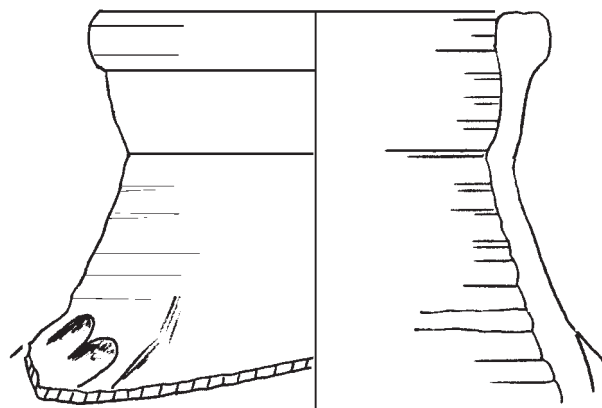


No. 31 C-1115 [004]

0 1cm

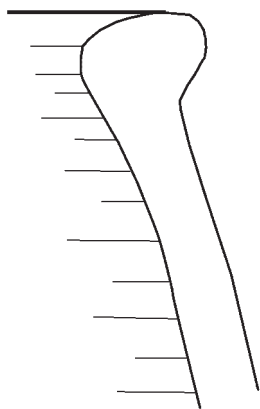
AREA II, L1001=L1004

Fig. 58:3

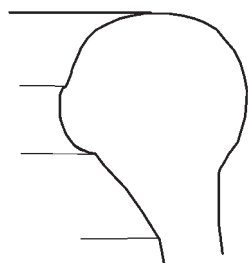


No. 32 P7053A

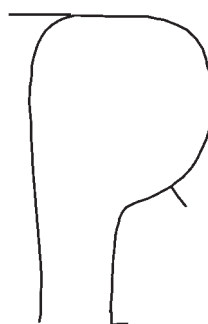
0 3cm



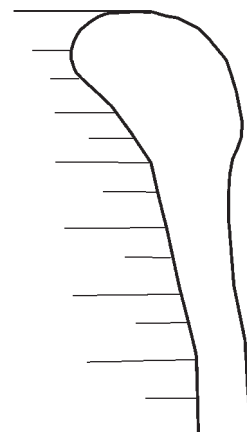
No. 33 C-1115 [029]



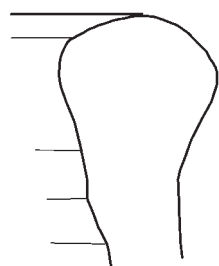
No. 34 C-1104 [006]



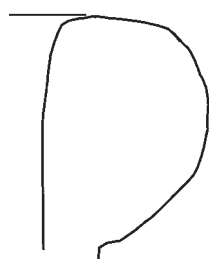
No. 36 C-1104 [026]



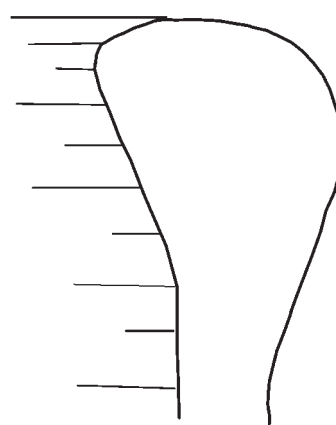
No. 37 C-1190 [002]



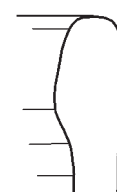
No. 38 C-1115 [044]



No. 39 C-1115 [031]



No. 40 C-1104 [030]

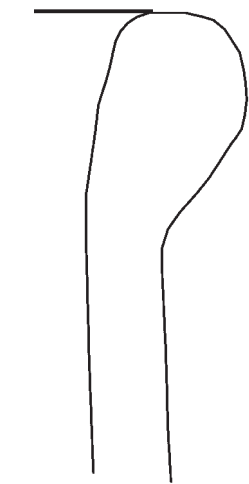


No. 41 C-1115 [032]

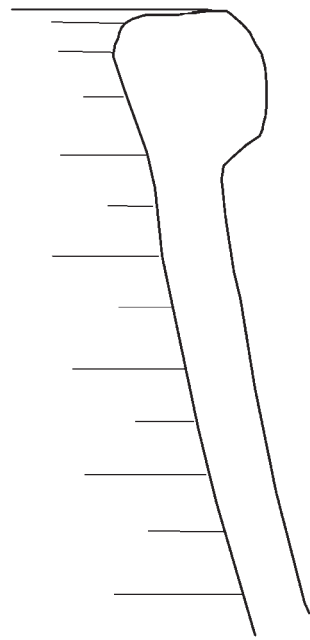
0 1cm

AREA II, L1001=L1004

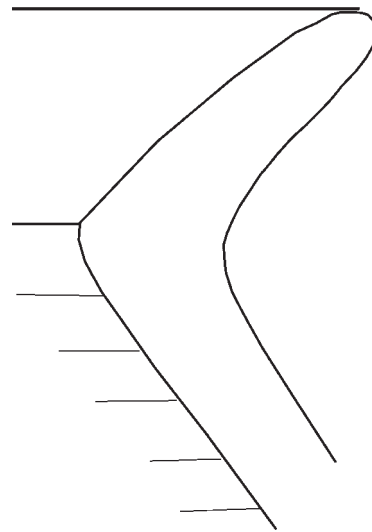
Fig. 58:4



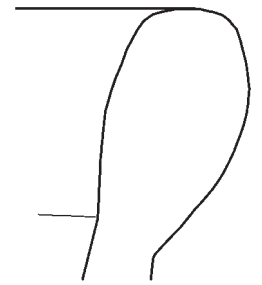
No. 42 C-1172 [012]



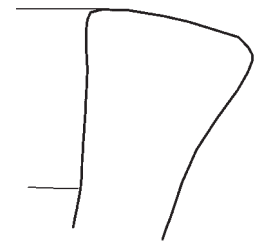
No. 43 C-1190 [001]



No. 44 C-1115 [001]

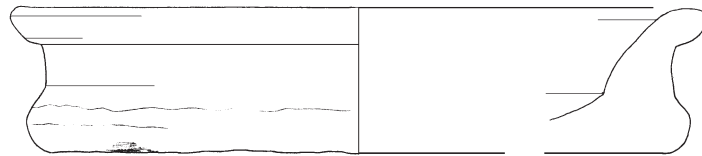


No. 45 C-1117 [002]

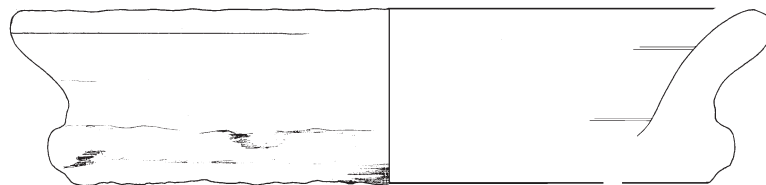


No. 46 C-1115 [003]

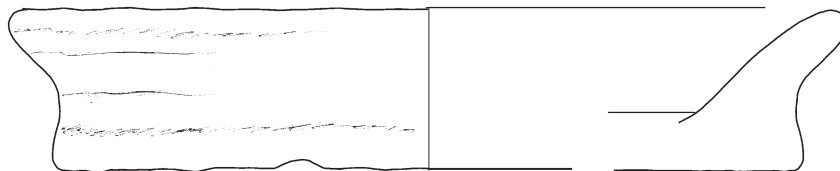
0 1cm



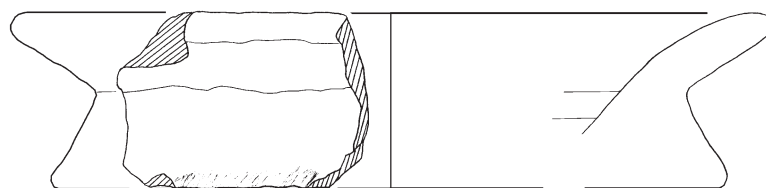
No. 49 P1024A



No. 50 P1030A



No. 51 P1033A

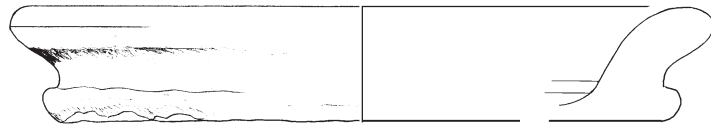


No. 52 P1034A

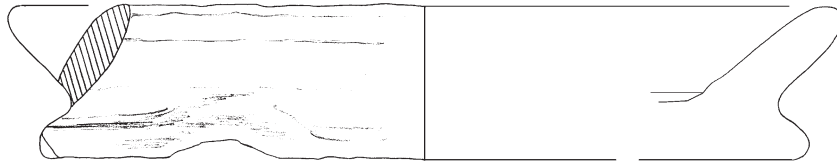
0 2cm

AREA II, L1001=L1004

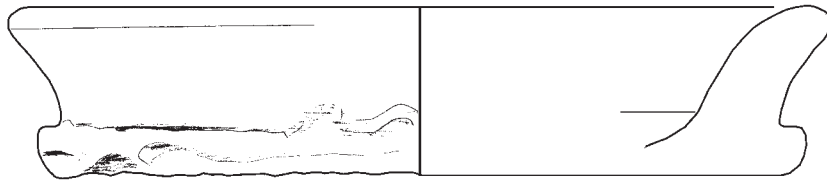
Fig. 58:5



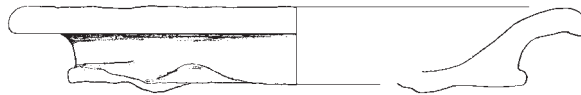
No. 53 P1035A



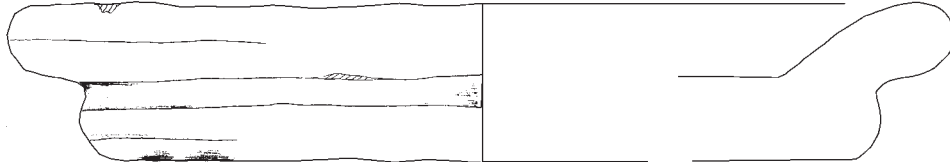
No. 55 P1025A



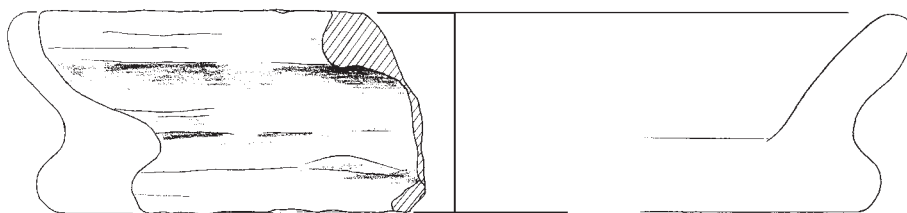
No. 56 P1026A



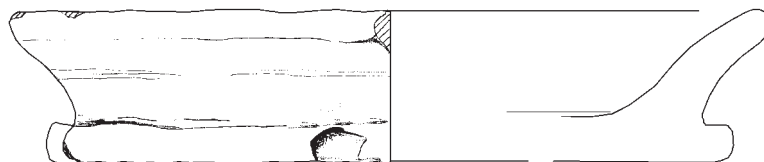
No. 57 P1071A



No. 58 P1307A



No. 60 P1056A

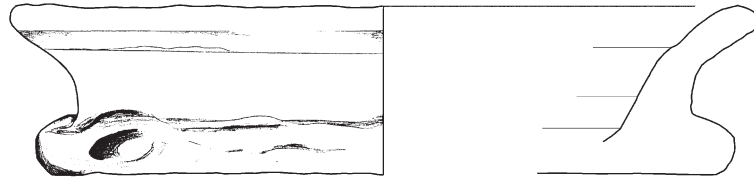


No. 61 P1074A

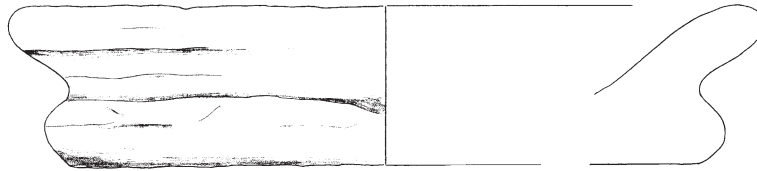
0 2cm

AREA II, L1001=L1004

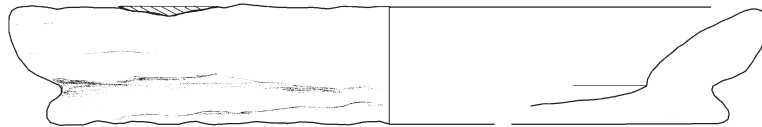
Fig. 58:6



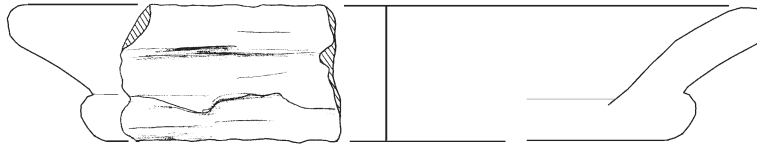
No. 62 P1075A



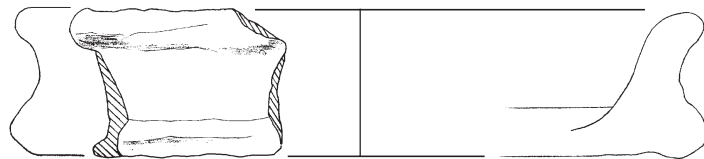
No. 63 P1076A



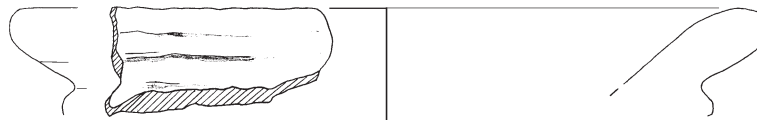
No. 64 P1078A



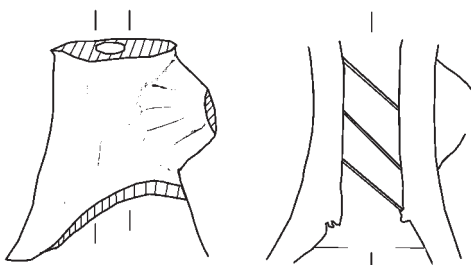
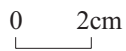
No. 65 P1083A



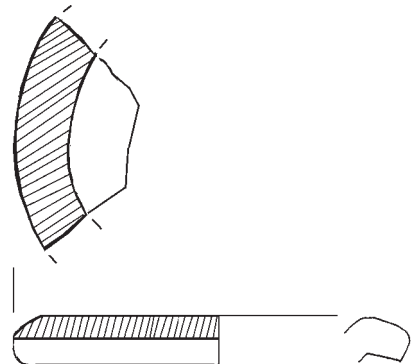
No. 66 P1085A



No. 66bis P1077A



No. 67 P0036A

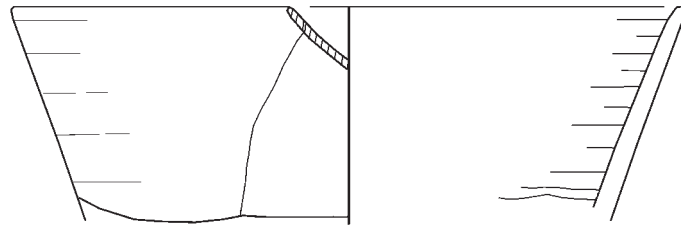


No. 68 P7032A

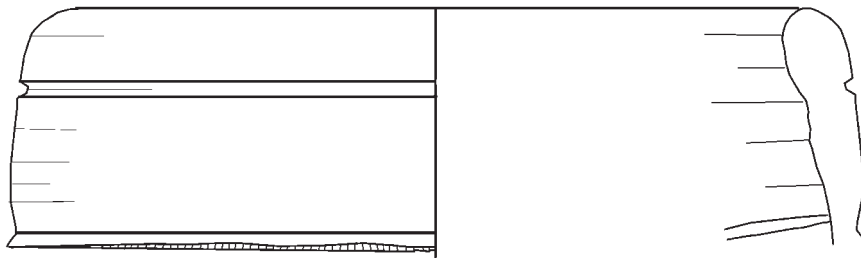


AREA II, L1001=L1004

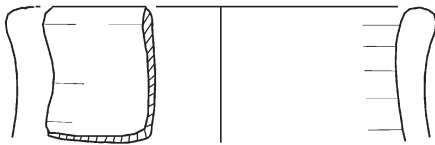
Fig. 58:7



No. 69 P0038A



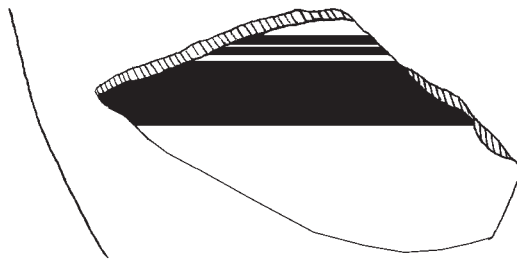
No. 70 P0218A



No. 71 P2019A

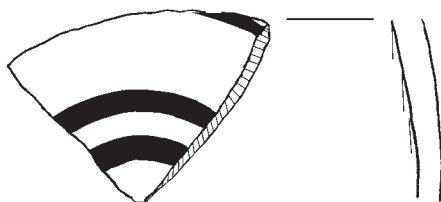


No. 76 P1095A



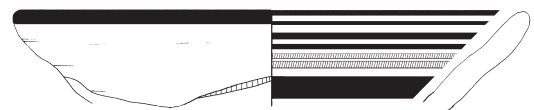
No. 78 P1053A

0 1cm



No. 79 P0030A

0 1cm

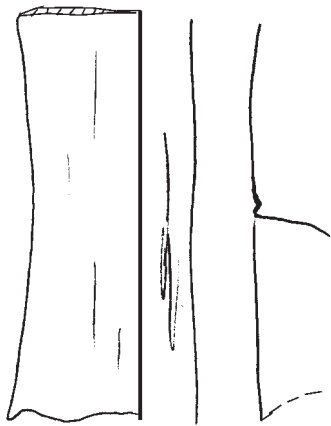


No. 80 P0042A

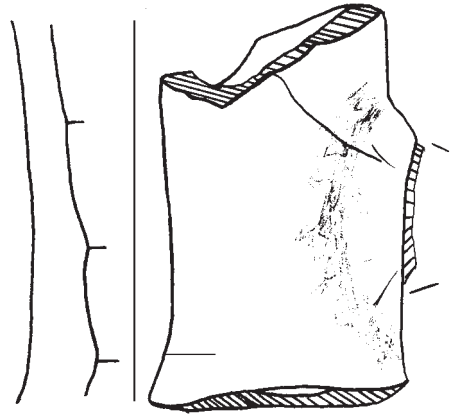
0 2cm

AREA II, L1001=L1004

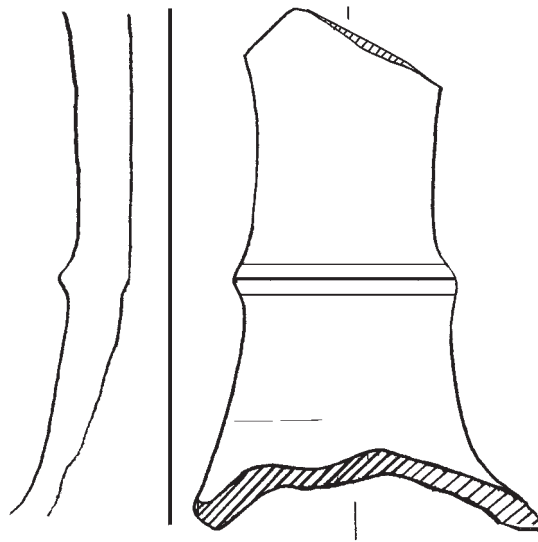
Fig. 58:8



No. 81 P0028A

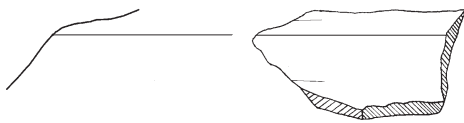


No. 82 P2025A



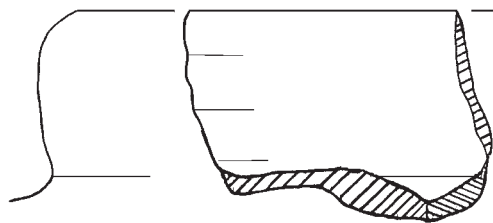
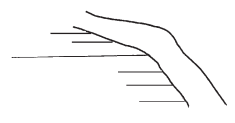
No. 83 P1063A

0 1cm



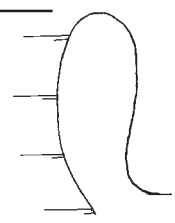
No. 85 P1091A

0 2cm



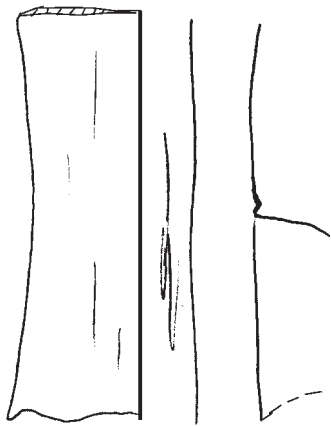
No. 90 P2035A

0 1cm

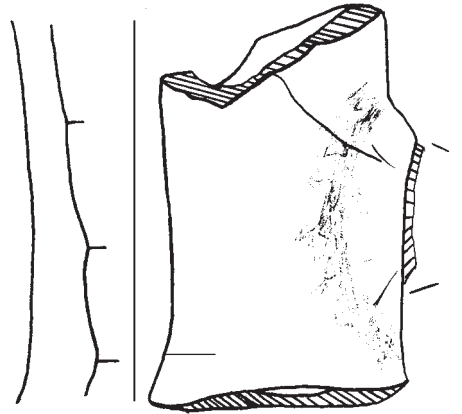


AREA II, L1001=L1004

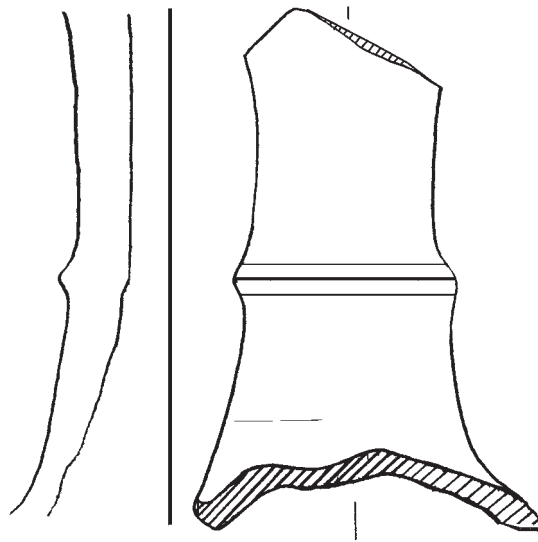
Fig. 58:9



No. 81 P0028A

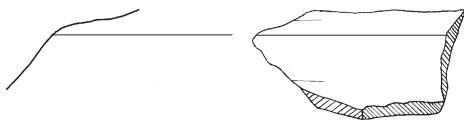


No. 82 P2025A



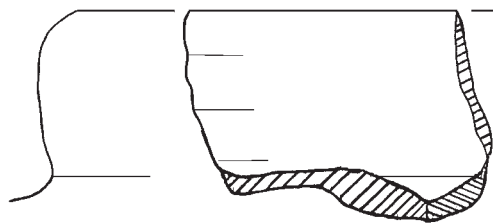
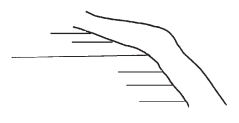
No. 83 P1063A

0 1cm



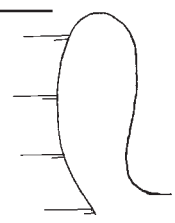
No. 85 P1091A

0 2cm



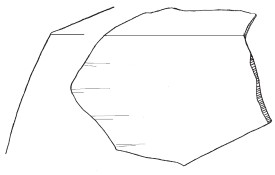
No. 90 P2035A

0 1cm

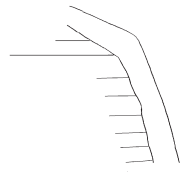


AREA II, L1001=L1004

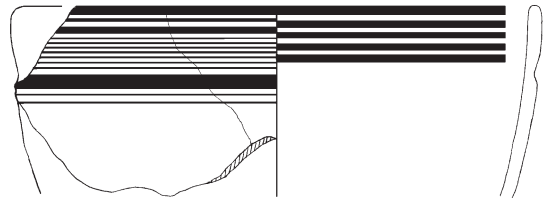
Fig. 58:9



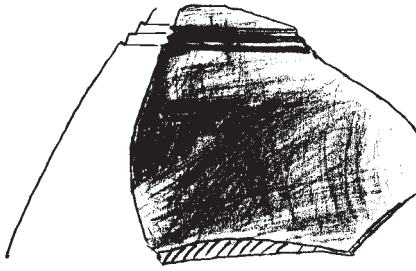
No. 92 P1088A



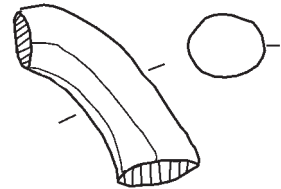
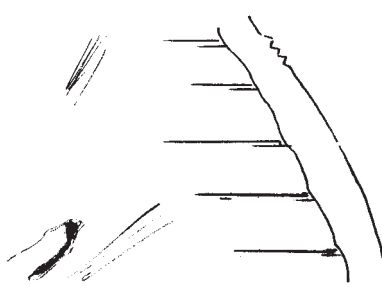
0 2cm



No. 93 P1044A



No. 94 P0024A

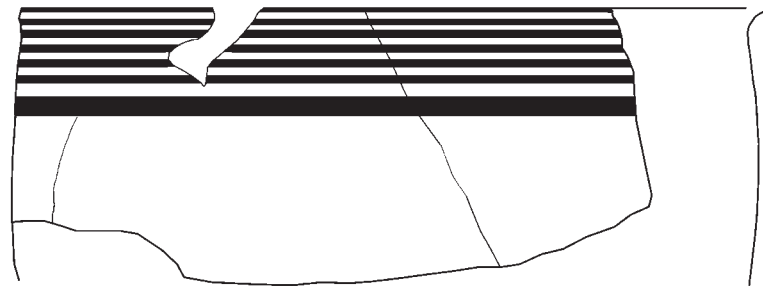
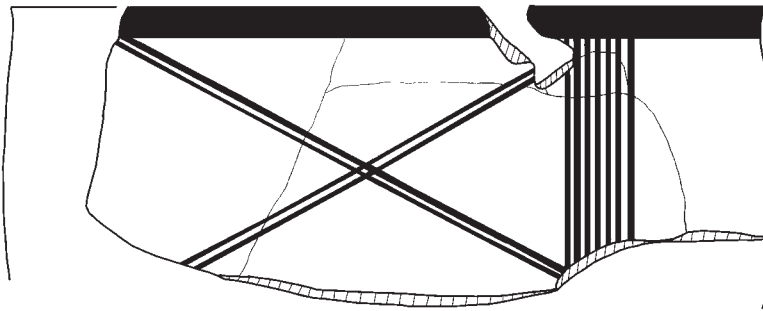
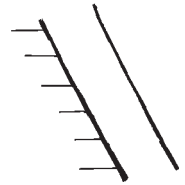


No. 95 P1221A



No. 96 P0228A

0 1cm

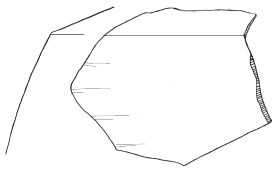


No. 98 P0208A

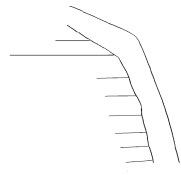
0 2cm

AREA II, L1001=L1004

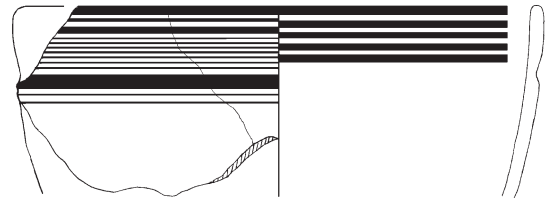
Fig. 58:10



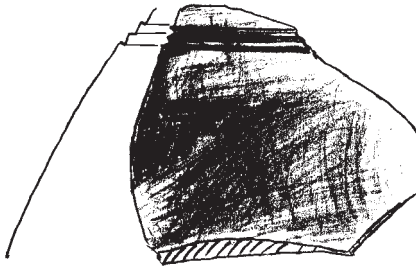
No. 92 P1088A



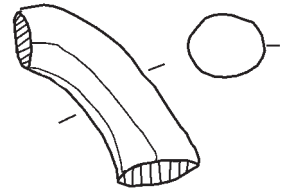
0 2cm



No. 93 P1044A



No. 94 P0024A

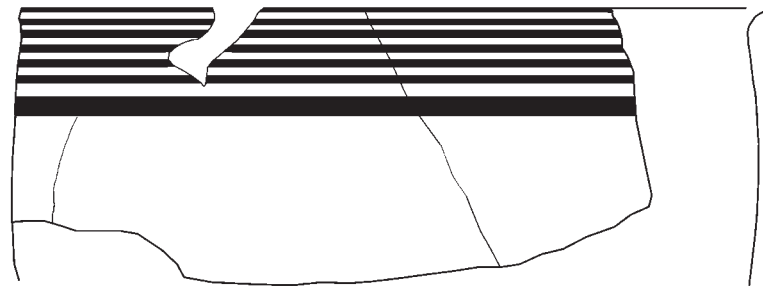
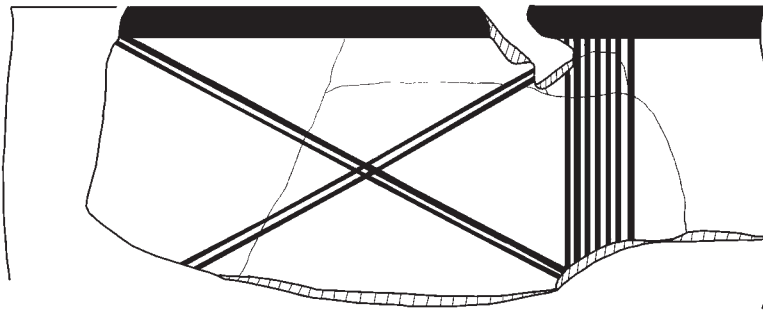
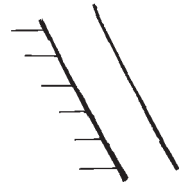


No. 95 P1221A



No. 96 P0228A

0 1cm



No. 98 P0208A

0 2cm

AREA II, L1001=L1004

Fig. 58:10



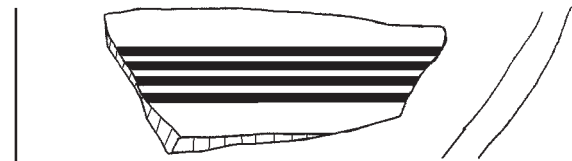
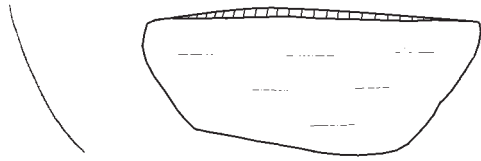
No. 99 P0776A

0 1cm



No. 100 P1040A

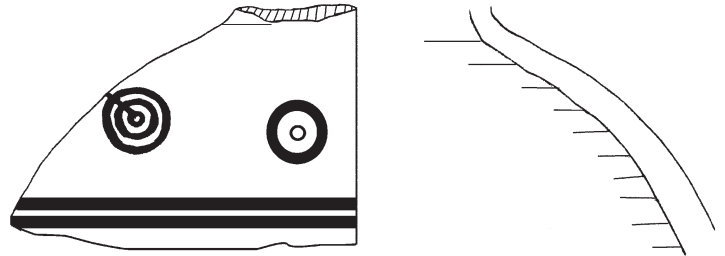
0 2cm



No. 101 P3000A



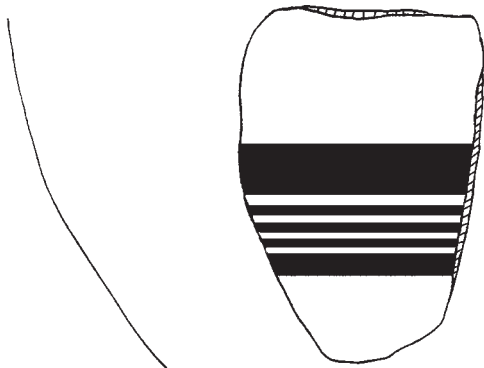
No. 102 P0226A



No. 103 P0367A

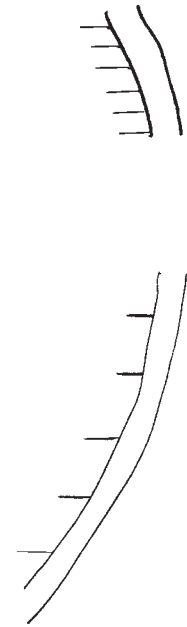


No. 105 P0375A



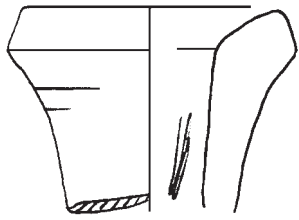
No. 107 P0374A

0 1cm

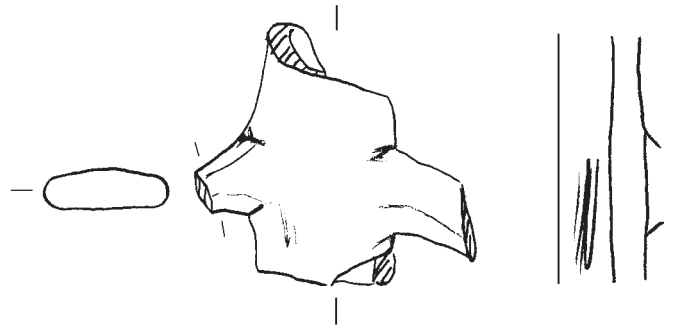


AREA II, L1001=L1004

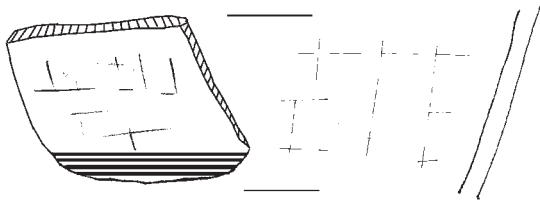
Fig. 58:11



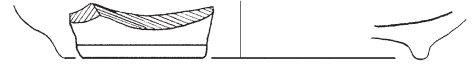
No. 108 P7098A



No. 110 P7008A



No. 112 P7104A



No. 113 P0745A



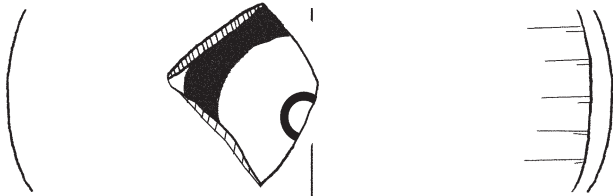
No. 114 P0368A



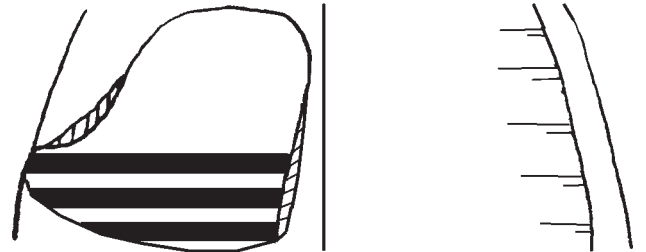
No. 115 P0376A



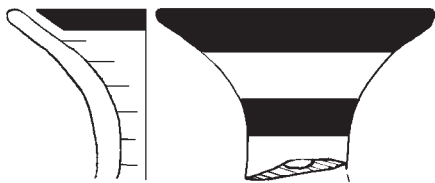
No. 116 P0377A



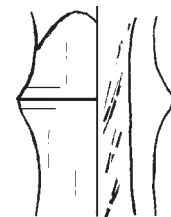
No. 117 P0771A



No. 118 P0775A



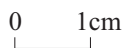
No. 119 P1097A



No. 120 P1179A

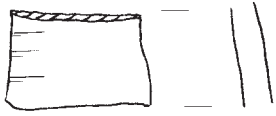


No. 121 P0354A

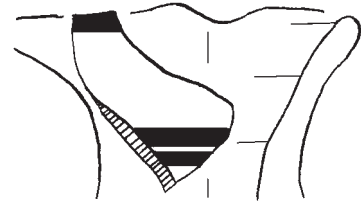


AREA II, L1001=L1004

Fig. 58:12



No. 121bis P1051A



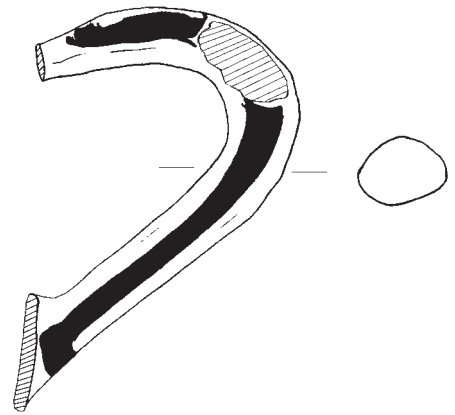
No. 122 P1041A



No. 123 P0773A



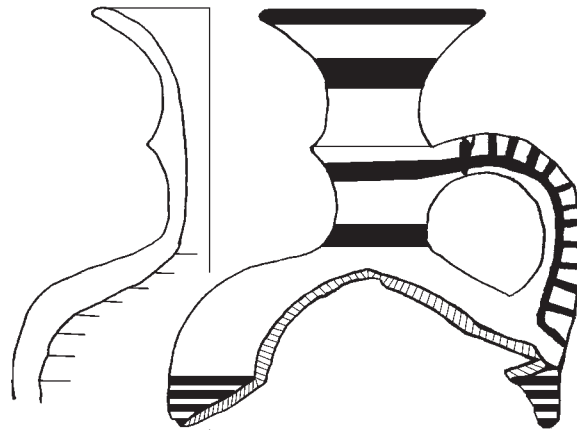
No. 124 P1093A



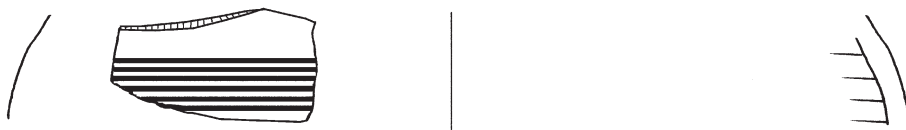
No. 125 P0216A



No. 126 P0219A



No. 127 P0362B



No. 128 P0366A

0 1cm

AREA II, L1001=L1004

Fig. 58:13

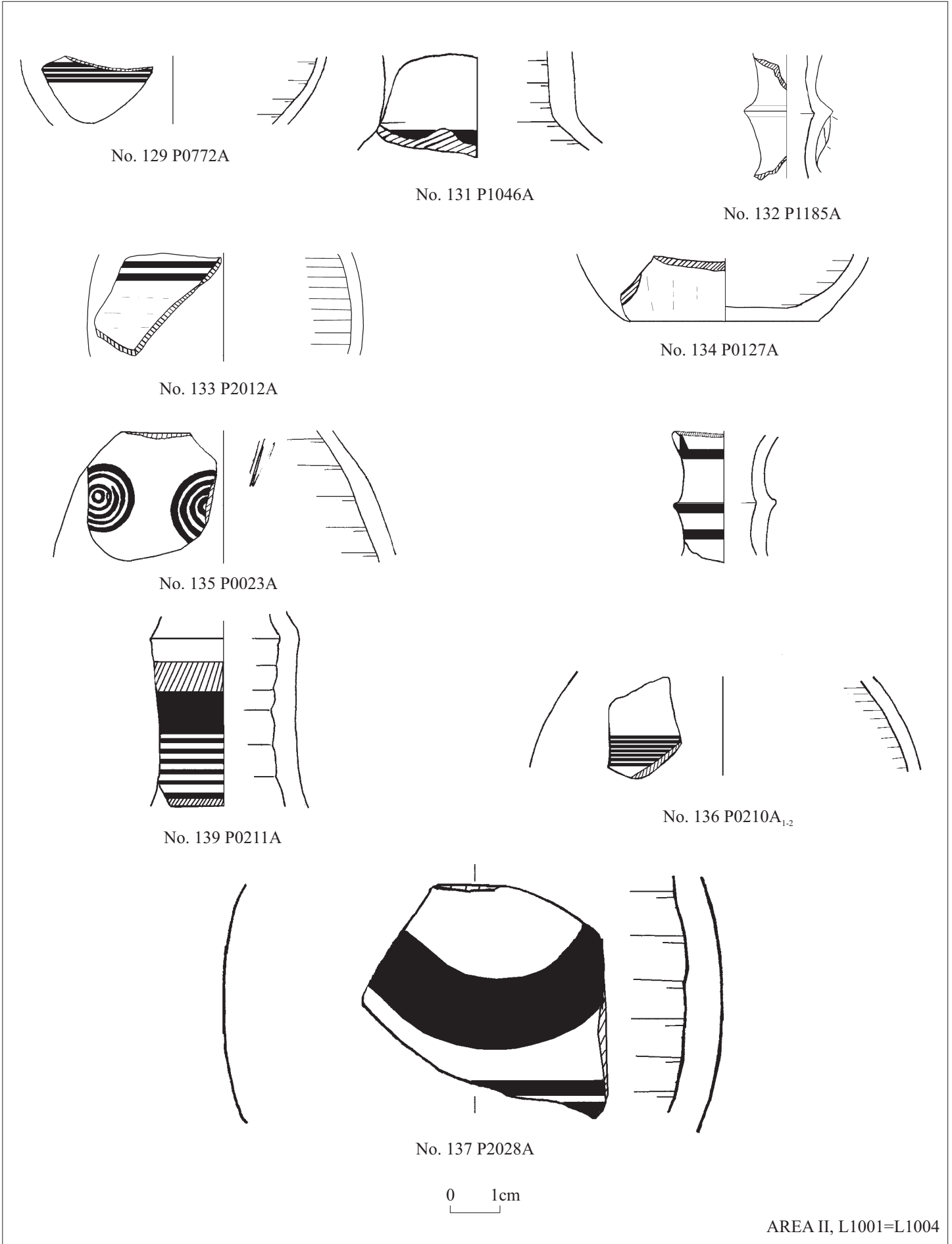


Fig. 58:14

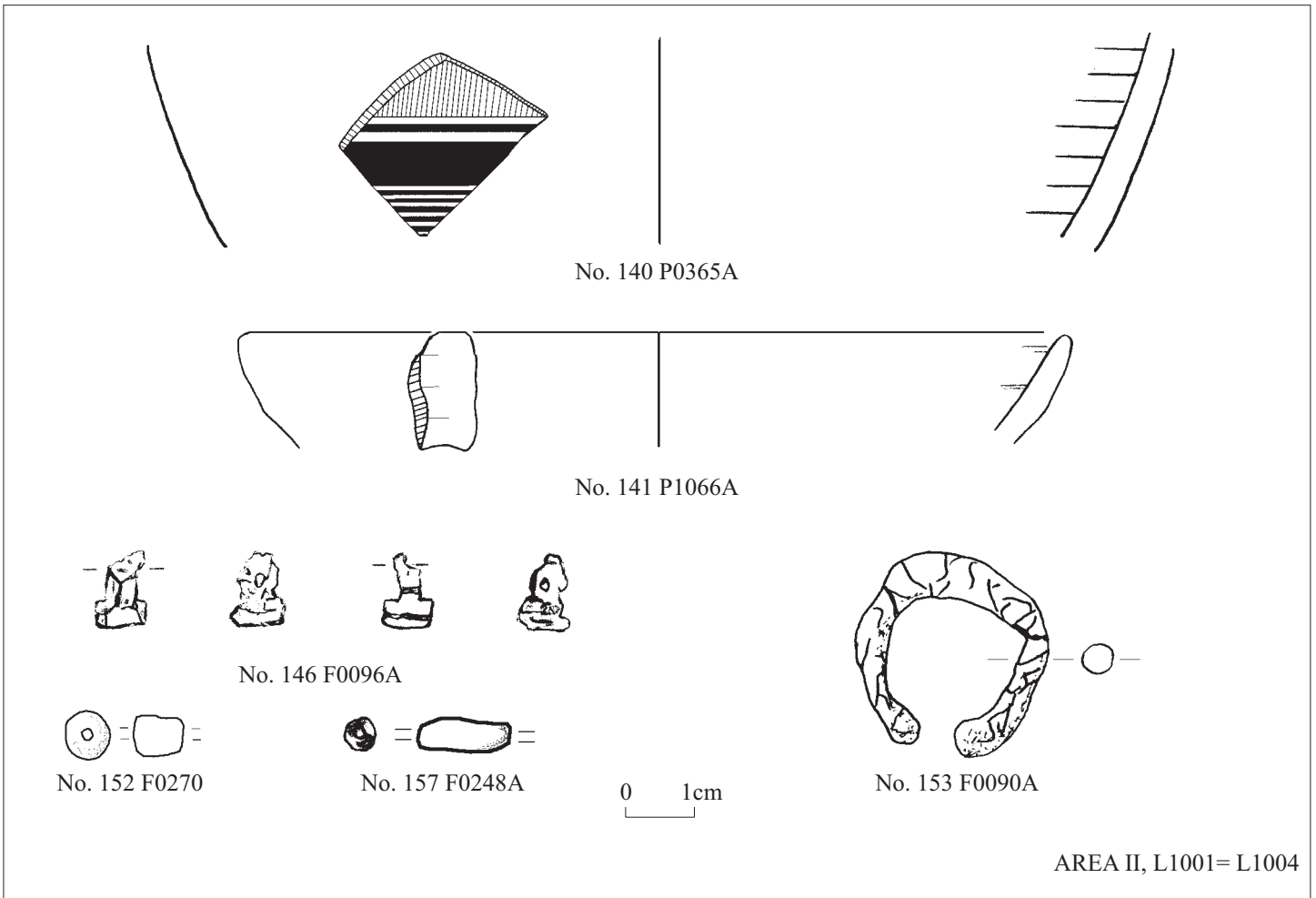
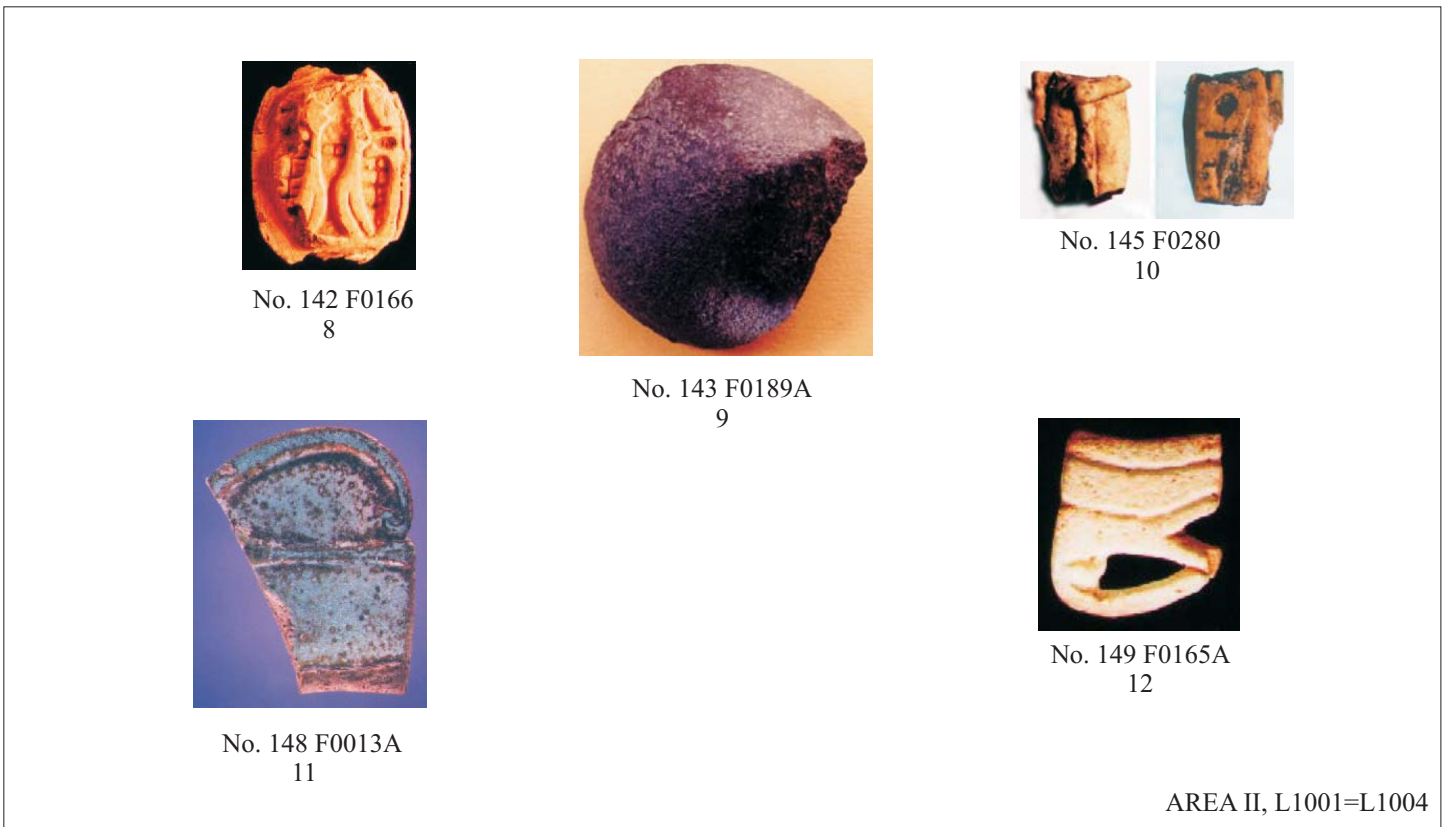
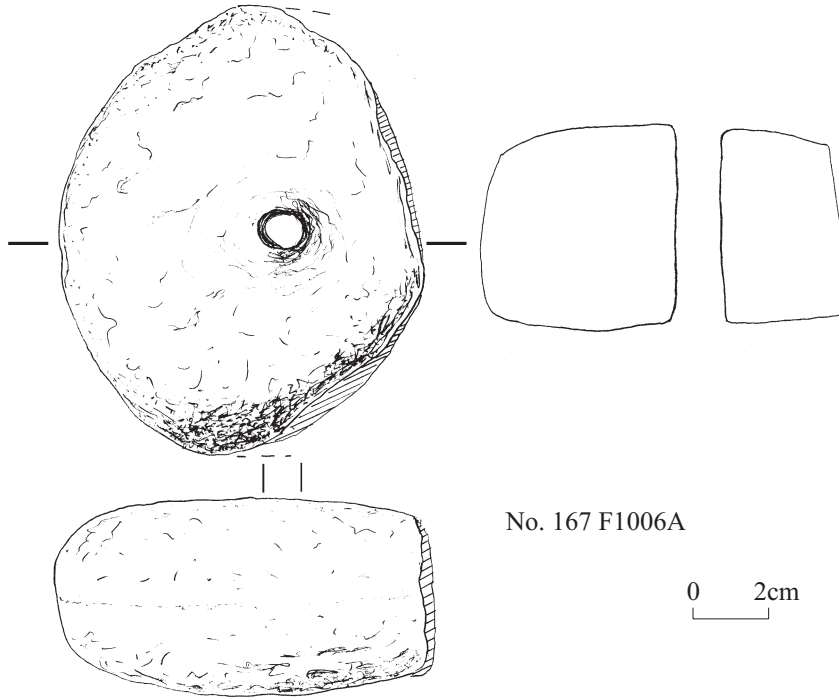
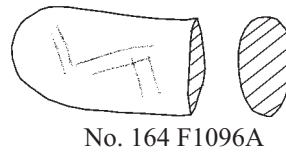
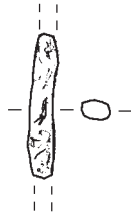
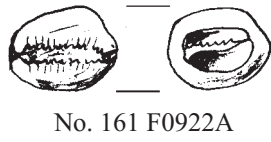
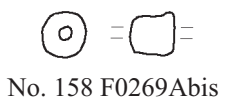
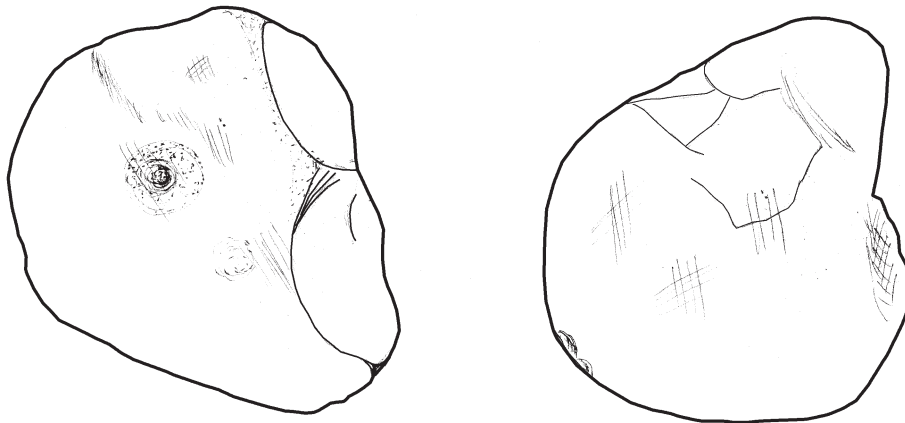


Fig. 58:15



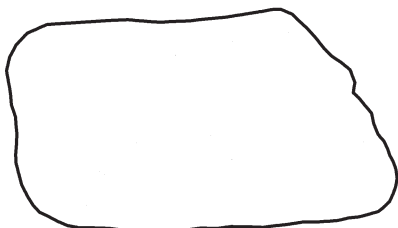


0 2cm



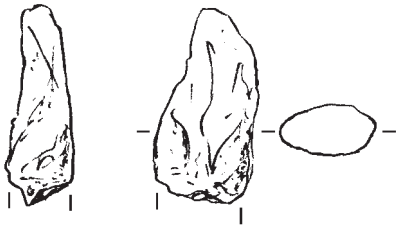
No. 168 F0109A

0 1cm



AREA II, L1001=L1004

Fig. 58:16



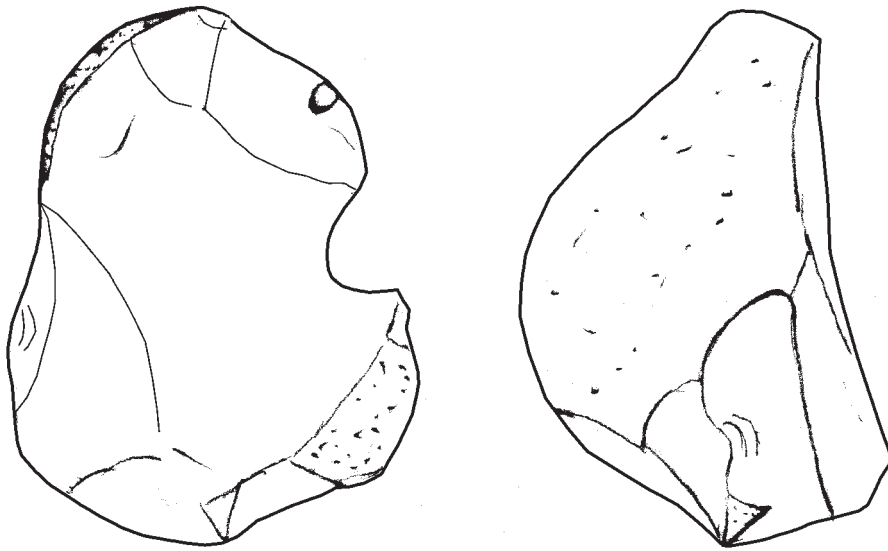
No. 175 F0231A



No. 179 F0553A



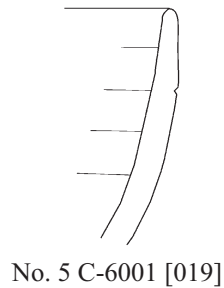
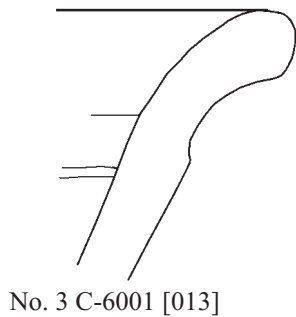
No. 198 F0224



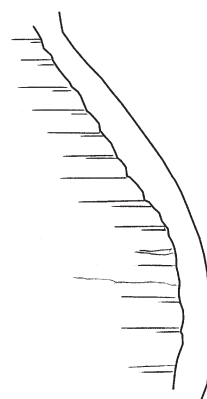
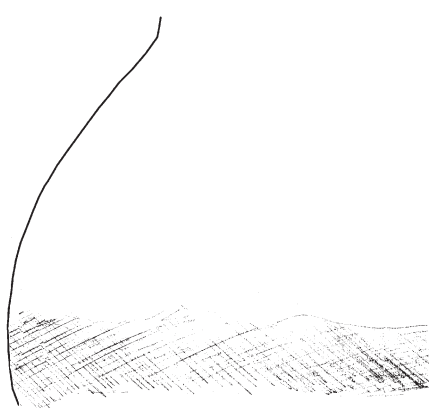
No. 199 F0957A

0 1cm

AREA II, L1001=L1004

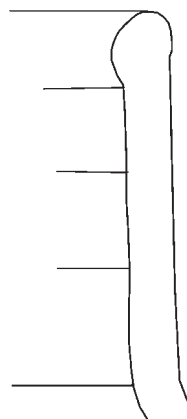
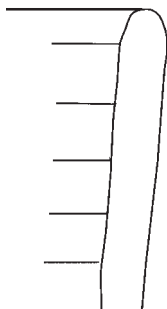
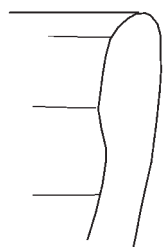


0 1cm



No. 6 C-6001 [022]

0 2cm

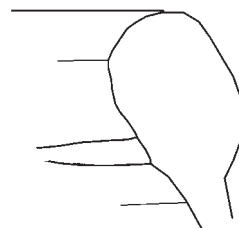
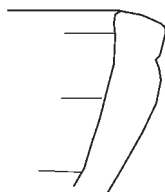
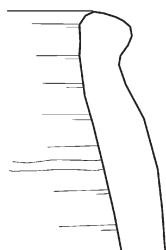


No. 7 C-6001 [016]

No. 8 C-6001 [054]

No. 9 C-6001 [053]

No. 10 C-6001 [055]



No. 11 C-6001 [014]

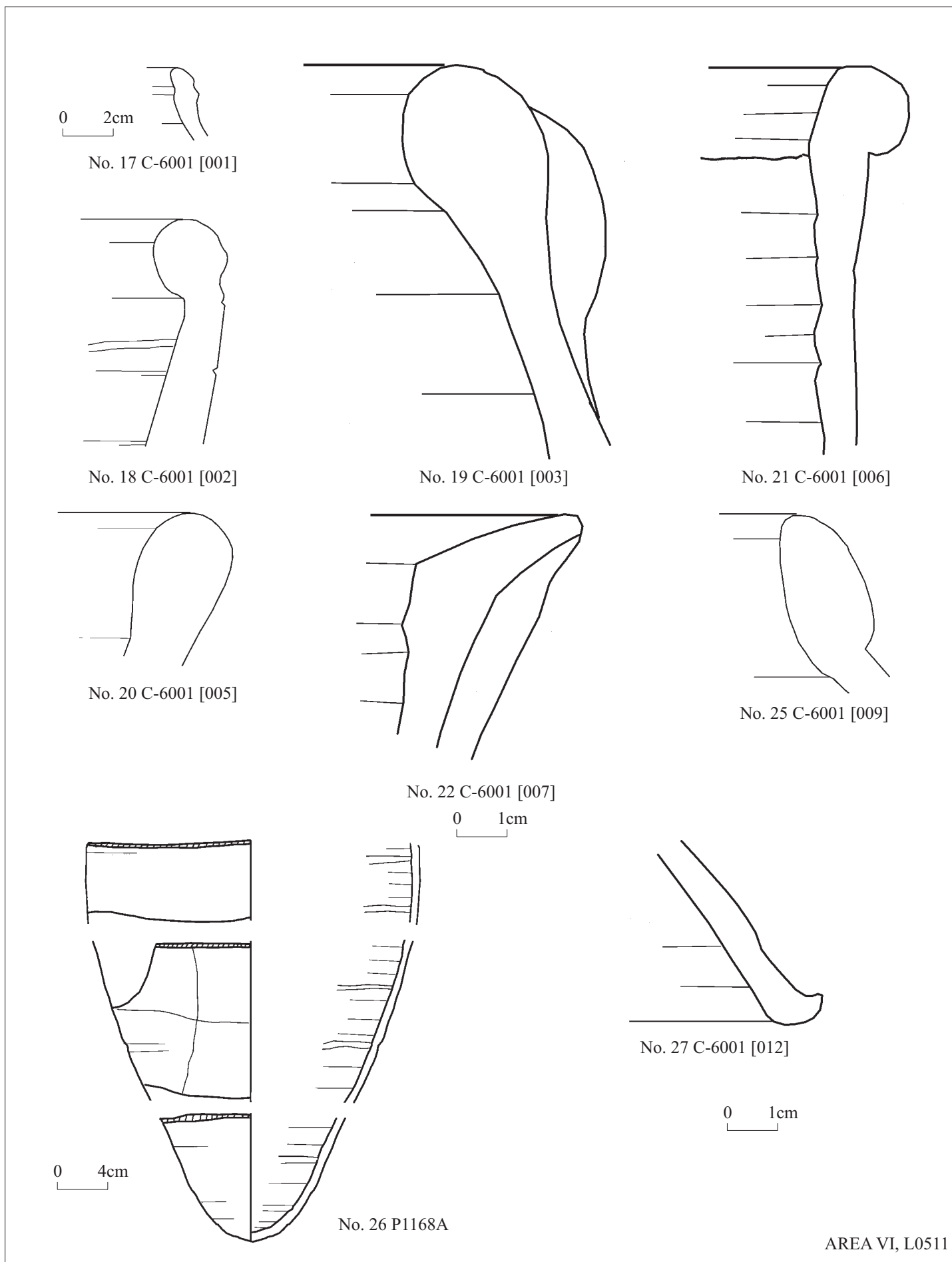
No. 12 C-6001 [017]

No. 15 C-6001 [018]

0 1cm

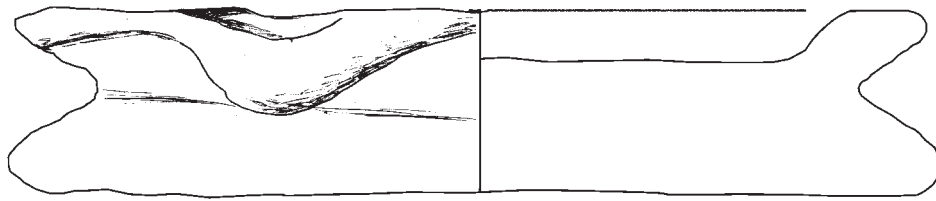
AREA VI, L0511

Fig. 1:1

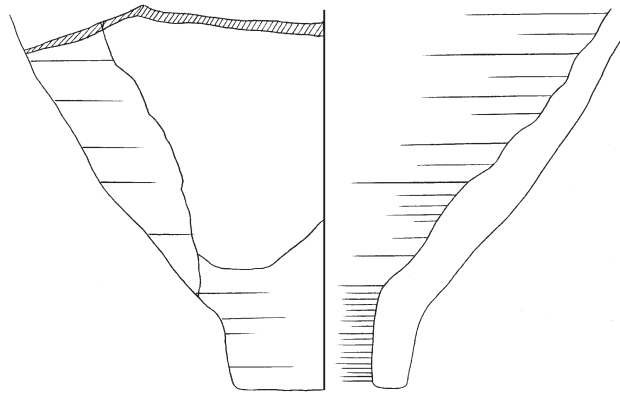


AREA VI, L0511

Fig. 1:2

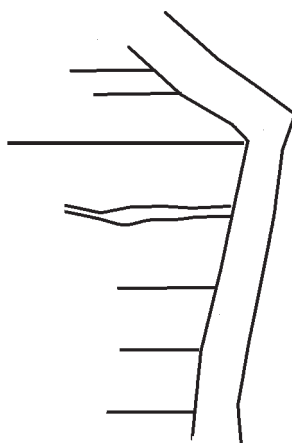


No. 28 P1100A

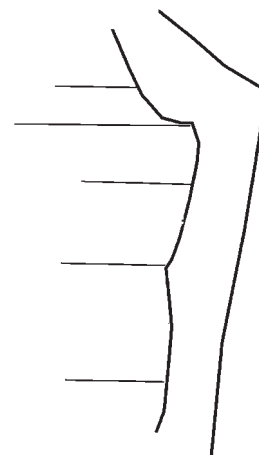


No. 29bis P1162A

0 2cm

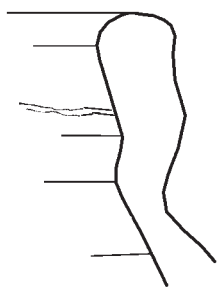


No. 32 C-6001 [040]

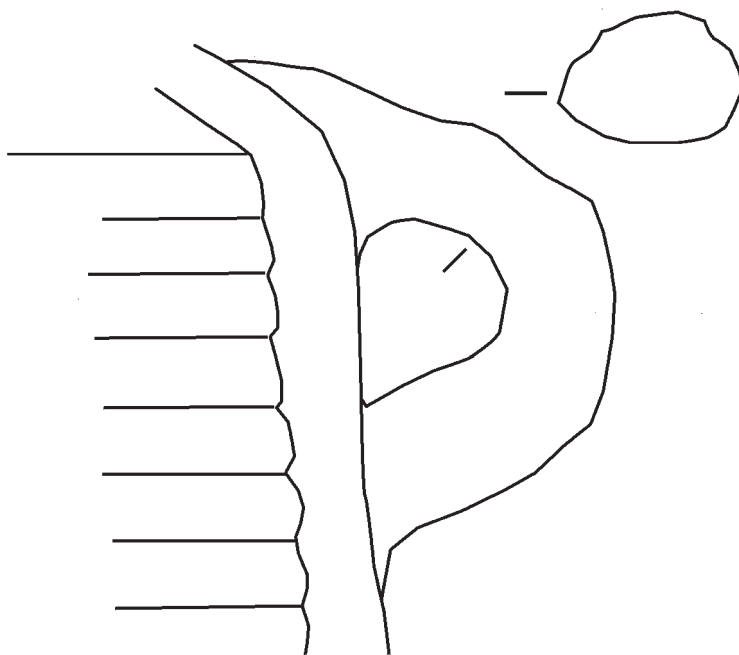


No. 34 C-6001 [024]

0 1cm



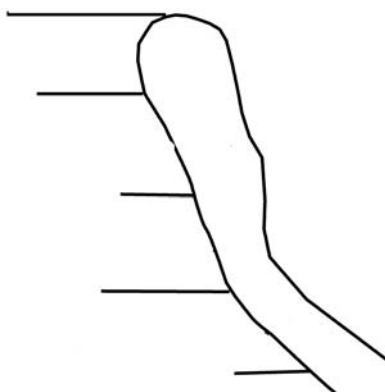
No. 36 C-6001 [028]



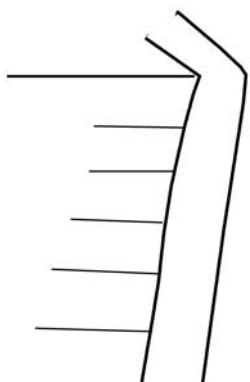
No. 37 C-6001 [036]



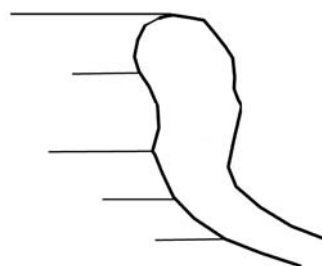
No. 38 C-6001 [037]



No. 42 C-6001 [039]



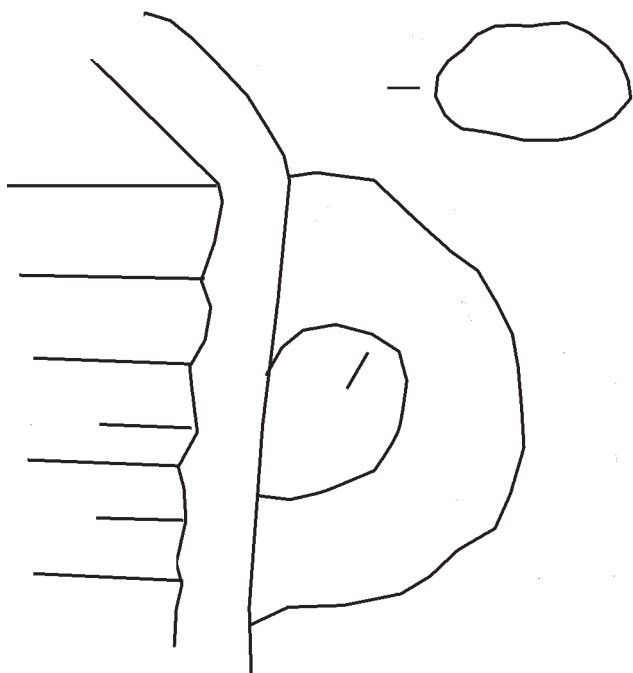
No. 43 C-6001 [030]



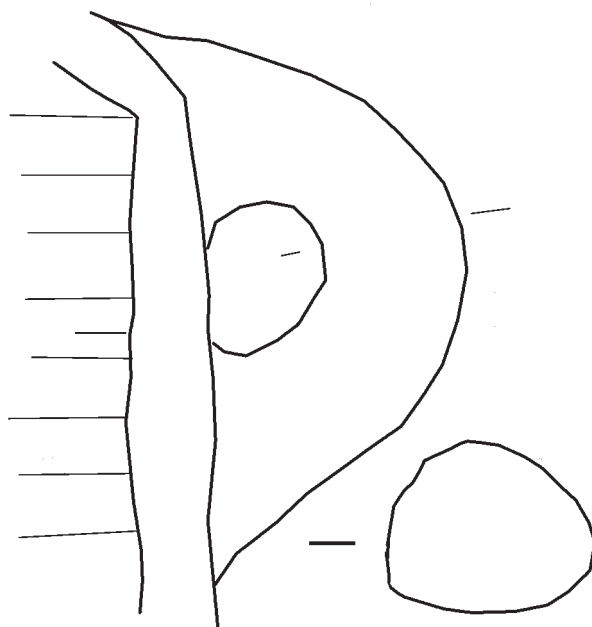
No. 51 C-6001 [025]



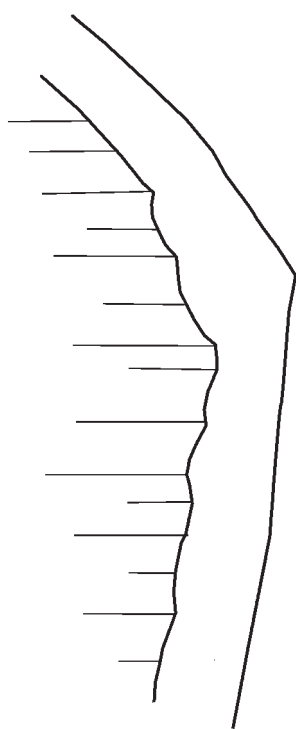
Fig. 1:4



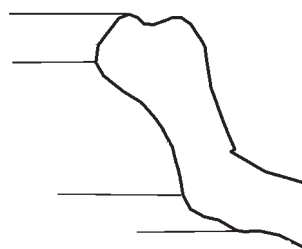
No. 52 C-6001 [038]



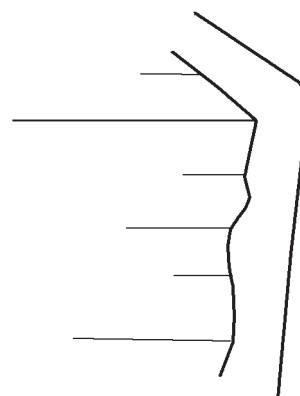
No. 53 C-6001 [033]



No. 54 C-6001 [031]

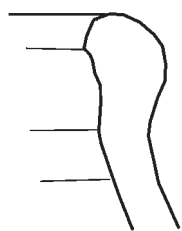


No. 56 C-6001 [027]

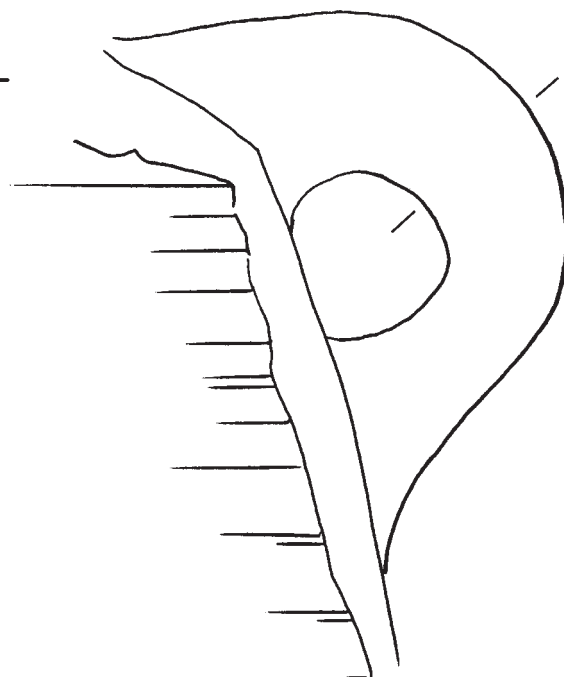


No. 57 C-6001 [029]

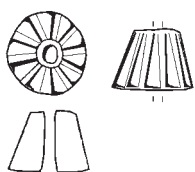
0 1cm



No. 63 C-6001 [026]



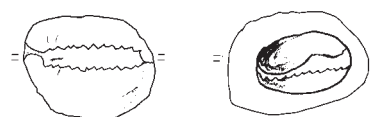
No. 64 C-6001 [032]



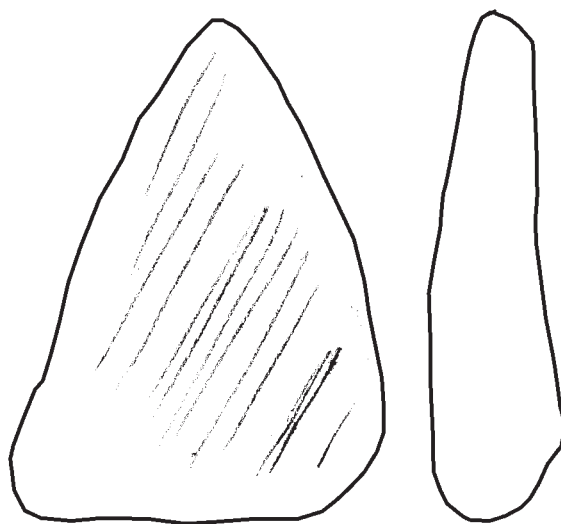
No. 65 F0585



No. 66 F0587A



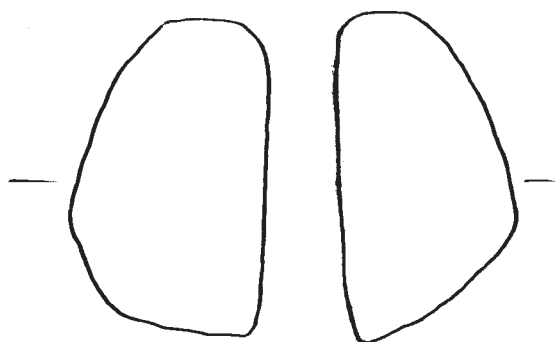
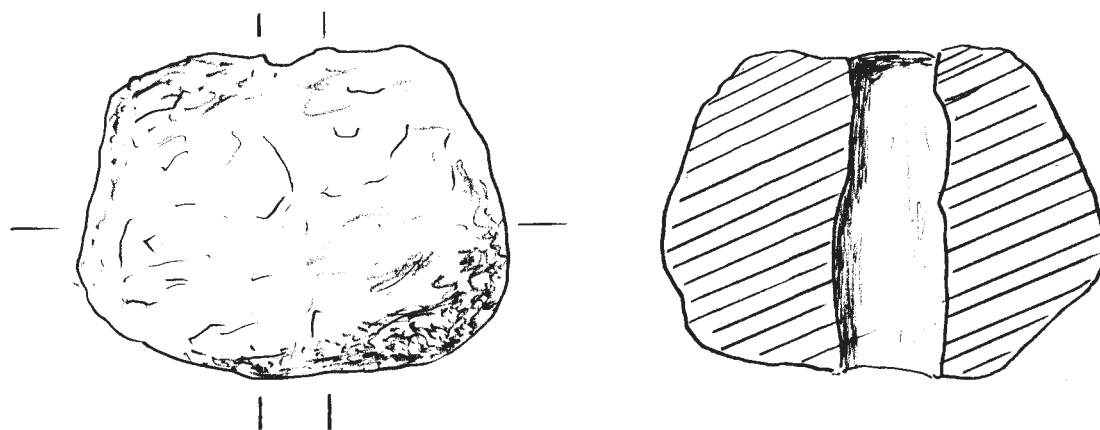
No. 67 F0921A



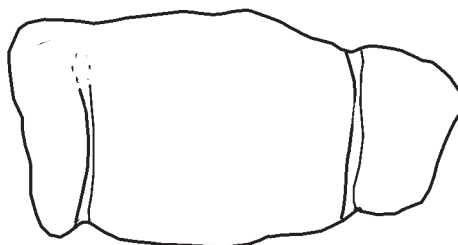
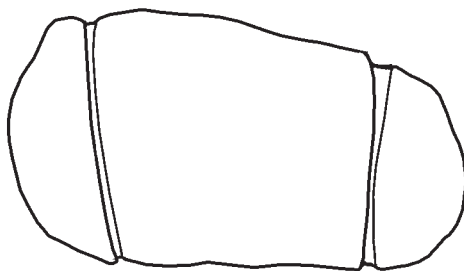
No. 68 F09181A



Fig. 1:6



No. 69 F0816A

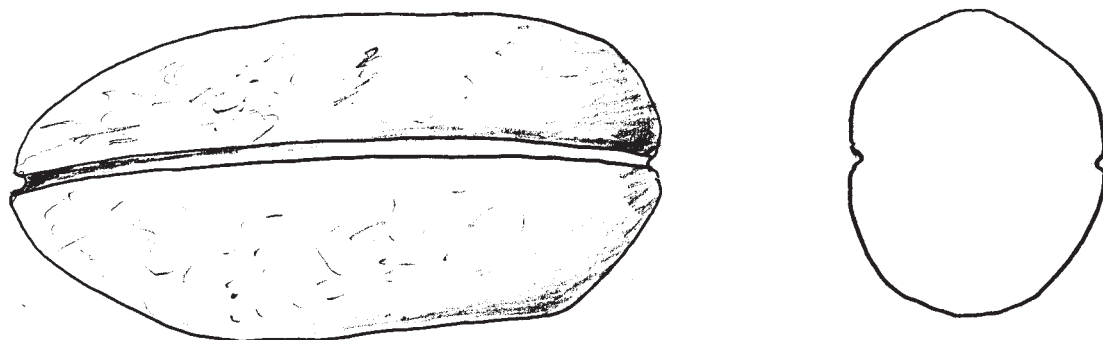


No. 70 F0911A

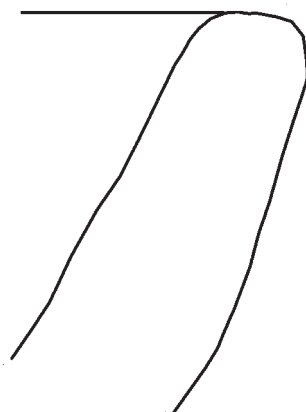
0 1cm

AREA VI, L0511

Fig. 1:7



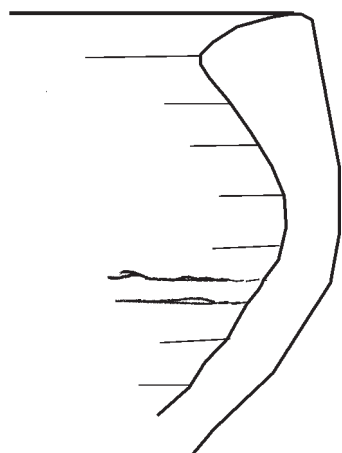
No. 71 F0814



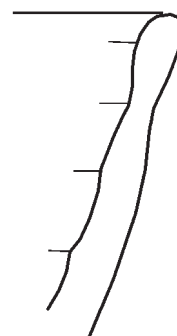
No. 72 F1091A

0 1cm

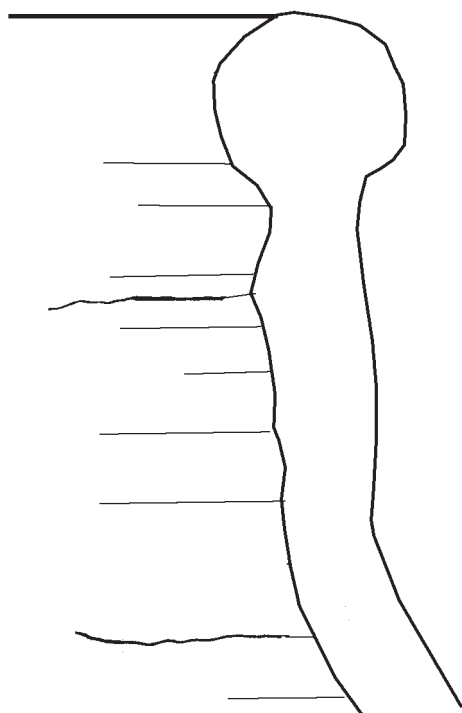
AREA VI, L0511



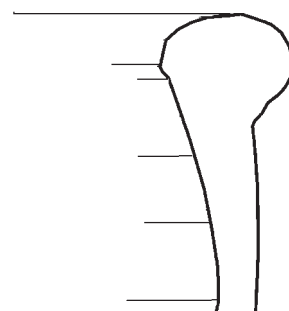
No. 1 C-6020 [002]



No. 2 C-6020 [004]



No. 3 C-6020 [001]



No. 4 C-6020 [003]

0 1cm

Fig. 2

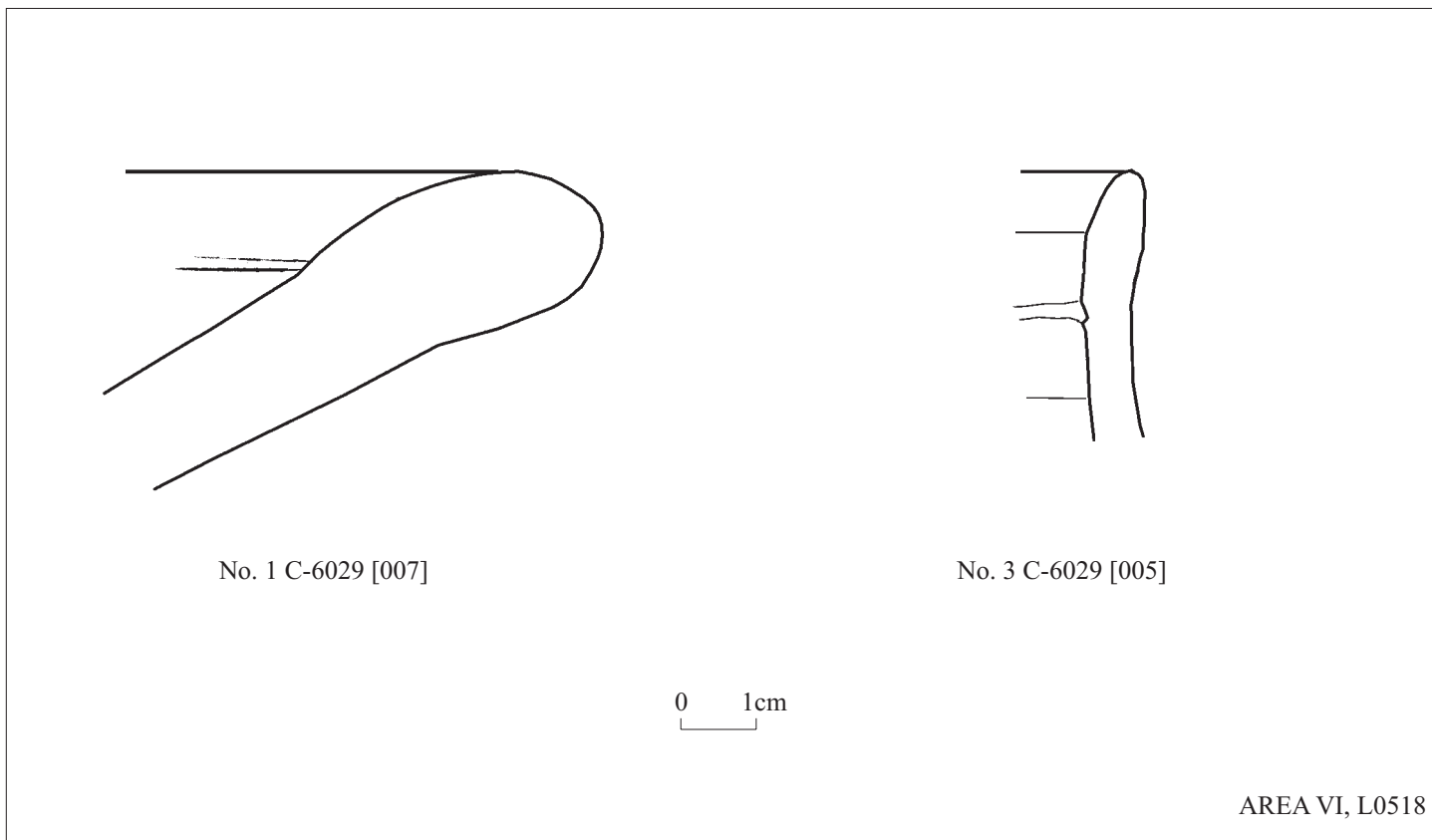


Fig. 3

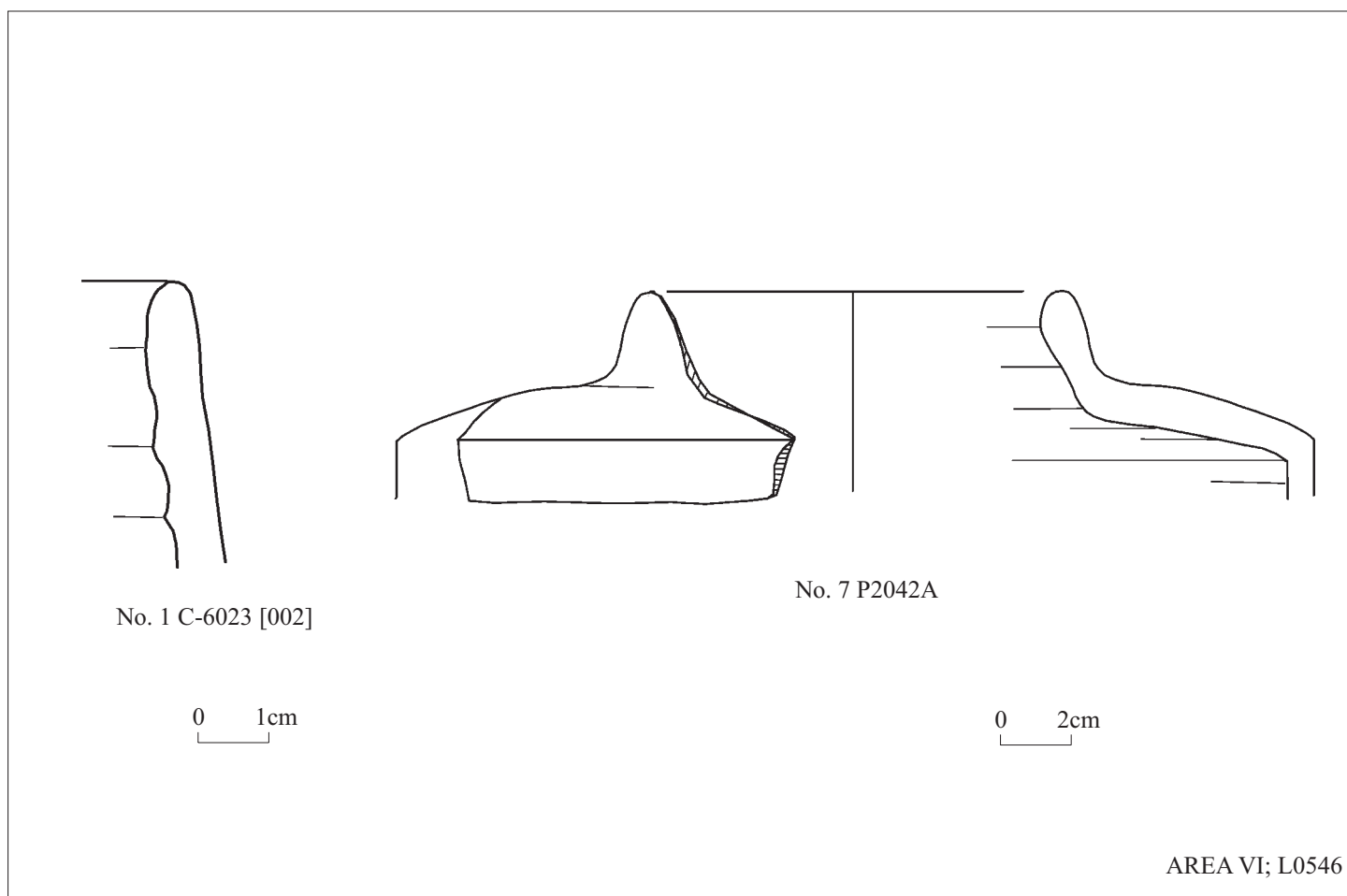
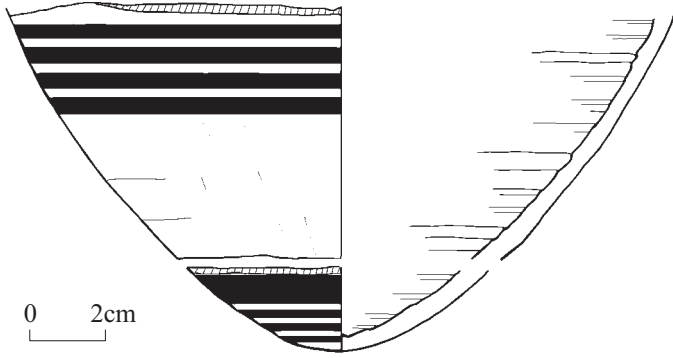
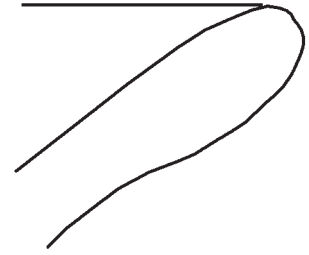


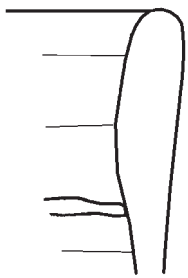
Fig. 4



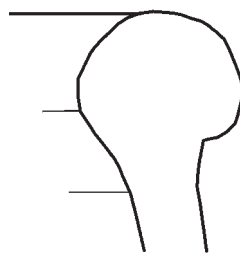
No. 2 P1136A



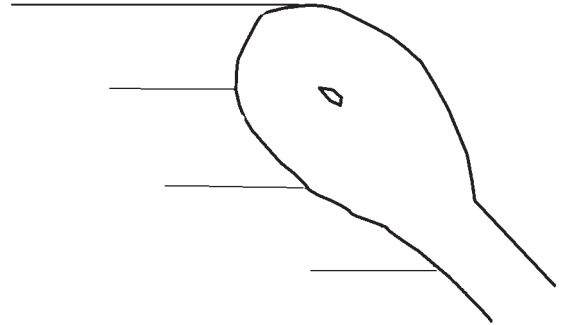
No. 3 C-6021 [004]



No. 4 C-6021 [003]



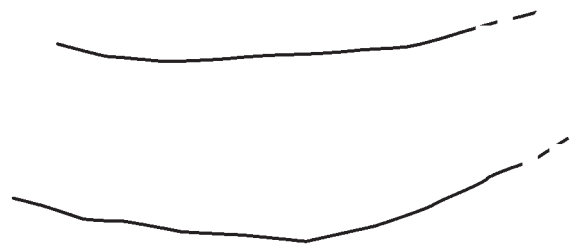
No. 7 C-6021 [006]



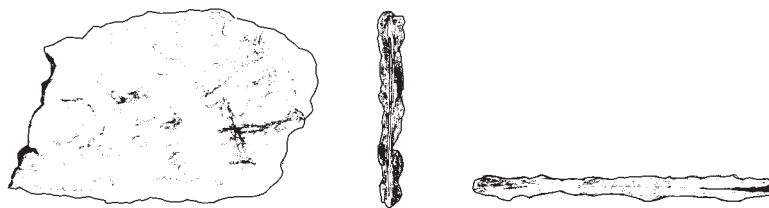
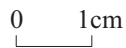
No. 8 C-6021 [005]



No. 13 F0705A



No. 14 C-6004 [013]



No. 16 F0728A

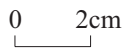
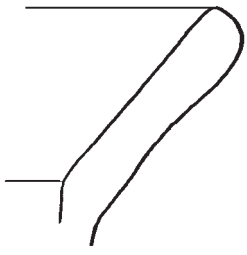
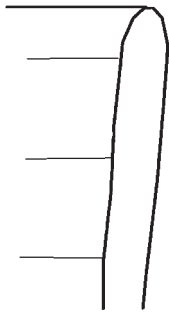


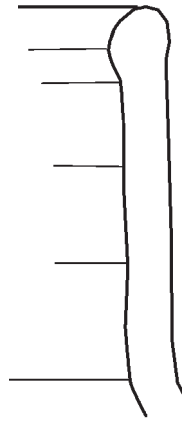
Fig. 5



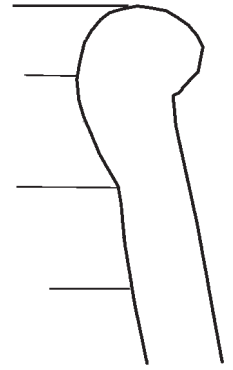
No. 1 C-6004 [009]



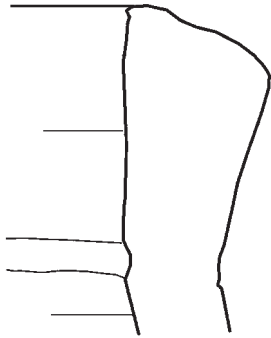
No. 2 C-6004 [008]



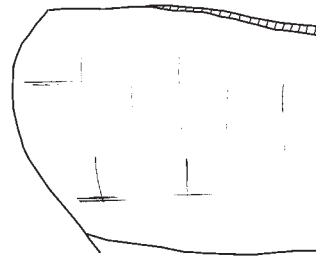
No. 3 C-6004 [004]



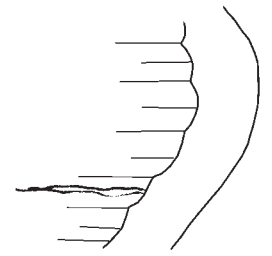
No. 4 C-6004 [007]



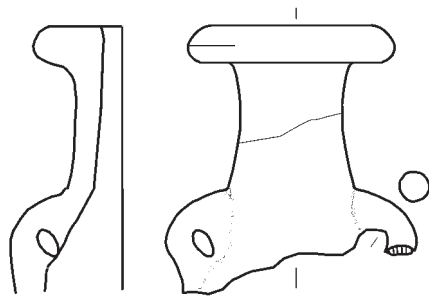
No. 5 C-6004 [006]



No. 10 P7096A



0 1cm



No. 12 P2020A

0 2cm

Fig. 6

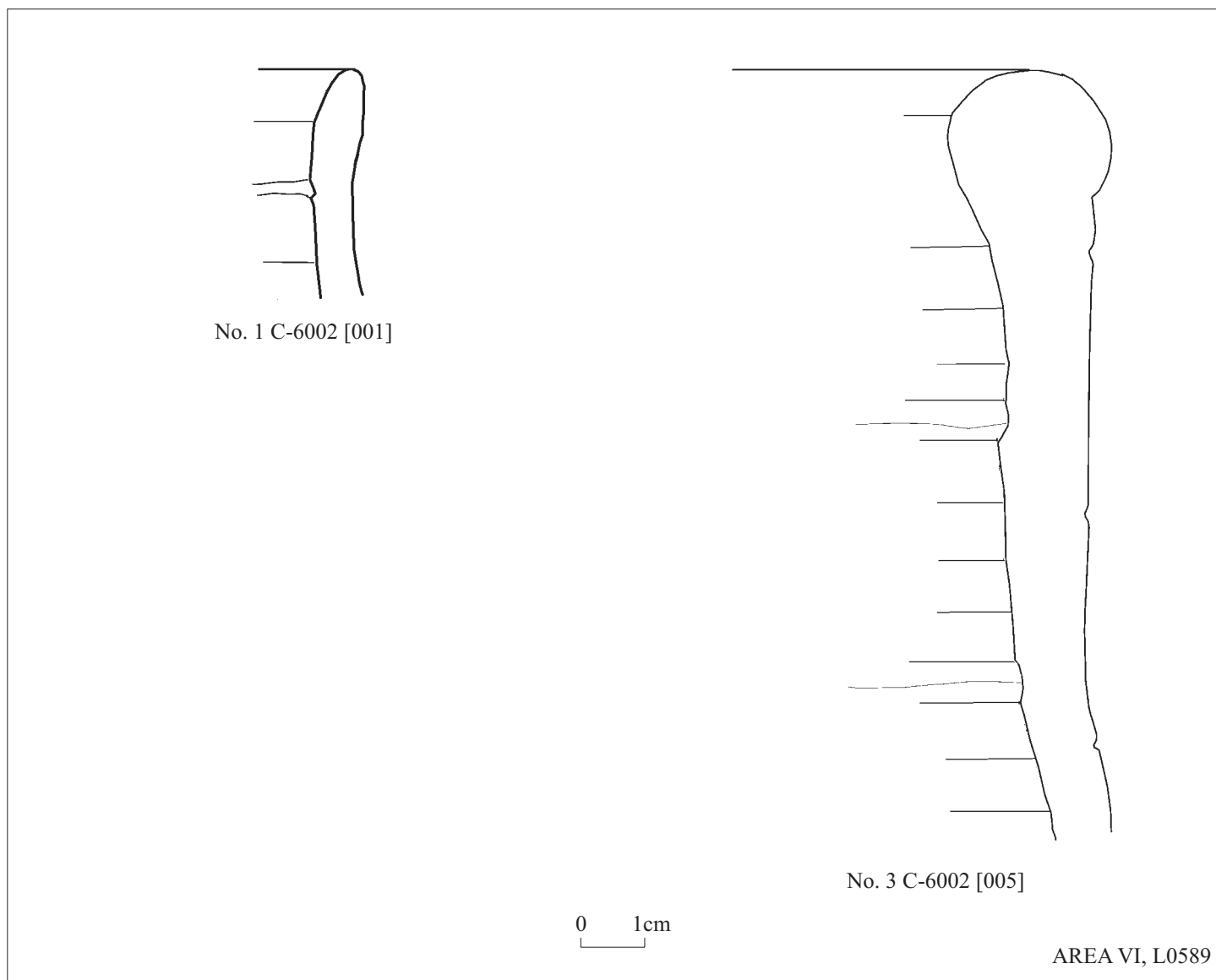


Fig. 7

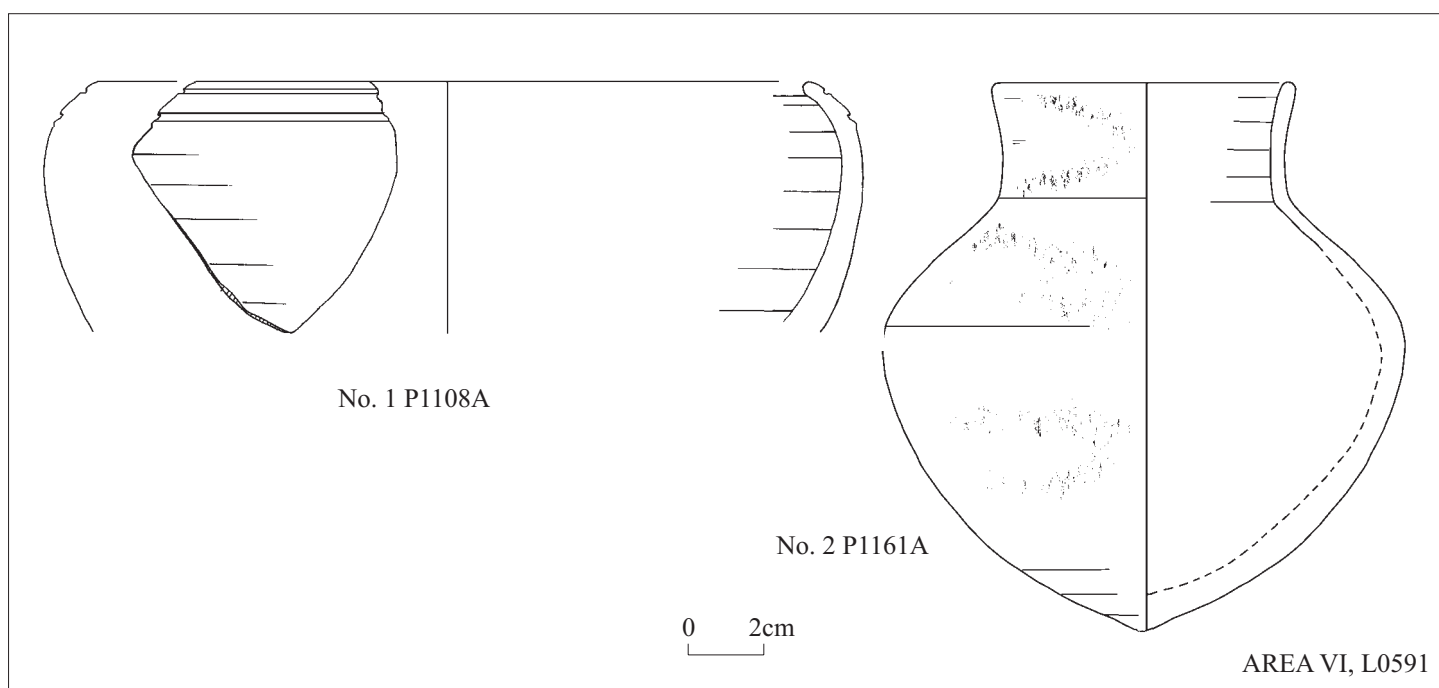
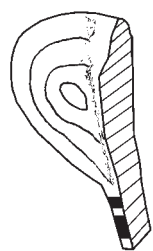
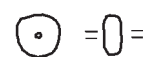
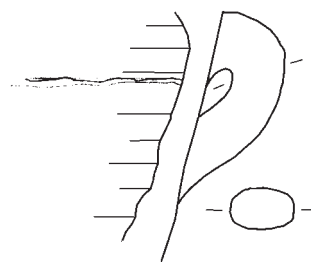


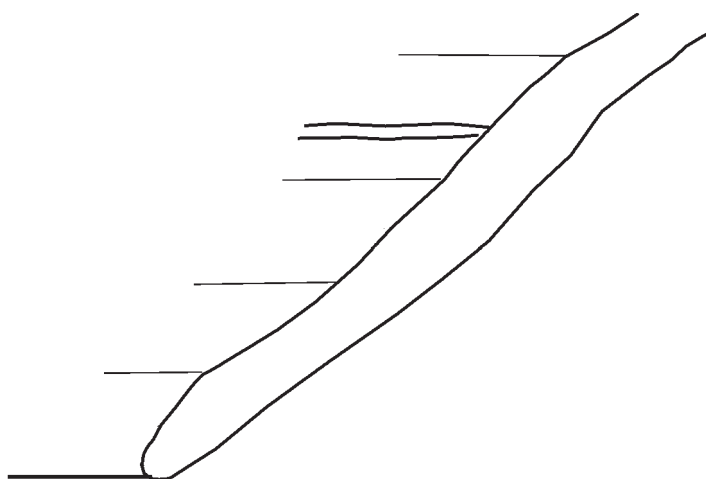
Fig. 8



No. 1 P7097A



No. 9 F0589A



No. 6 C-6014 [001]



No. 10 F0726



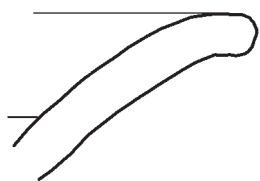
AREA VI, L0503

Fig. 9



No. 10 F0726

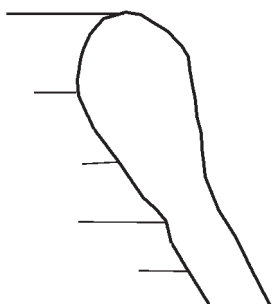
AREA VI, L0503



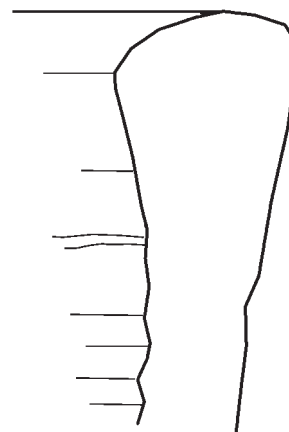
No. 1 C-6019 [003bis]



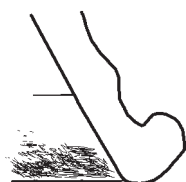
No. 3 C-6019 [002bis]



No. 4 C-6019 [003]



No. 5 C-6019 [001]



No. 6 C-6019 [002]



No. 8 C-6019 [001bis]

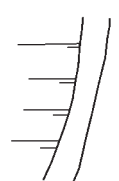
0 1cm

AREA VI, L0516

Fig. 10



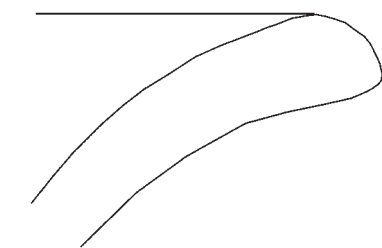
No. 1 P7103A



No. 3 C-6022 [007]



No. 2 P1140A



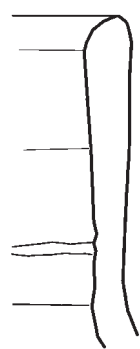
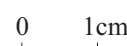
No. 4 C-6022 [009]



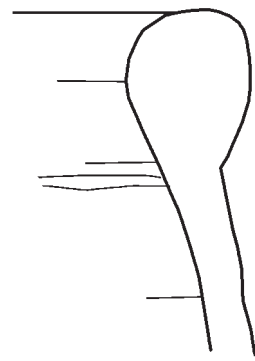
No. 5 C-6022 [010]



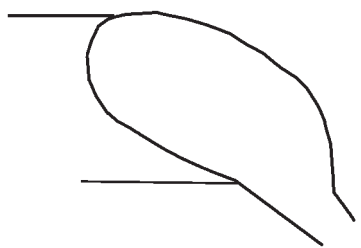
No. 6 C-6011 [01]



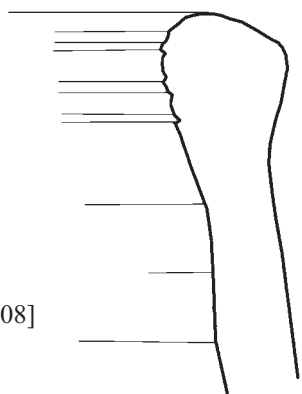
No. 7 C-6011 [010]



No. 9 C-6011 [011]



No. 10 C-6011 [014]

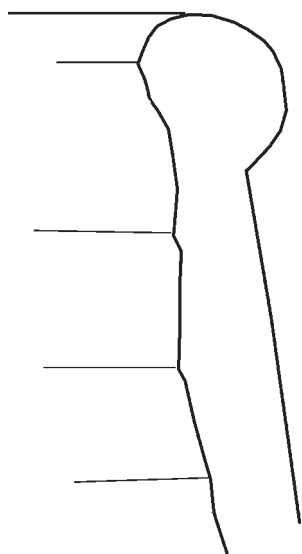


No. 11 C-6011 [008]



AREA VI, L0507

Fig. 11:1



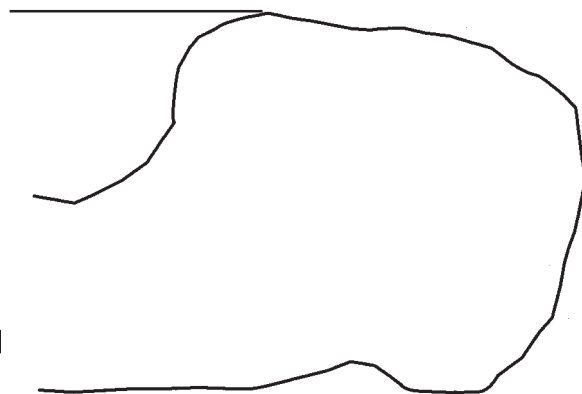
No. 12 C-6011 [005]



No. 16 C-6022 [004]



No. 17 C-6022 [003]



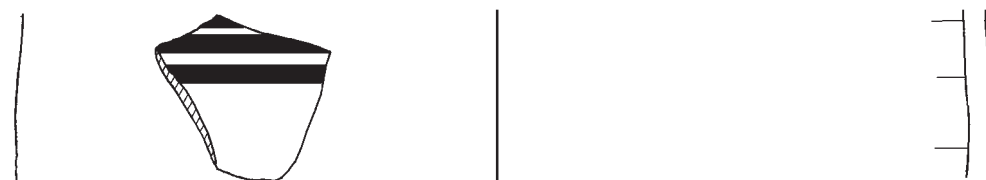
No. 18 C-6011 [001]

0 1cm

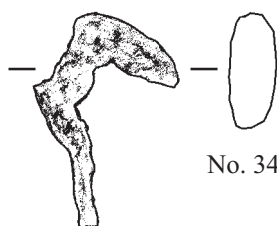


No. 29 P1103A

0 2cm



No. 32 P1180A

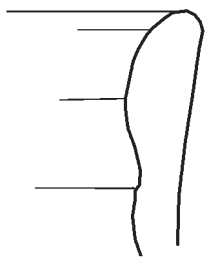


No. 34 F0690A

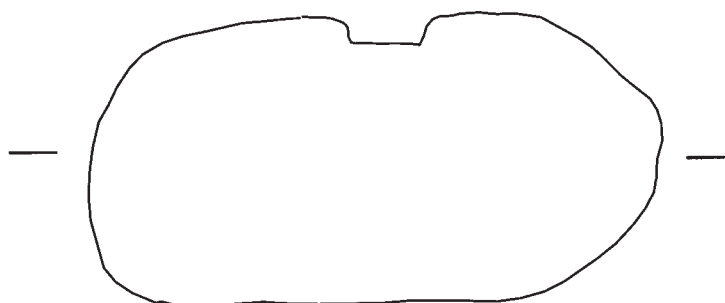
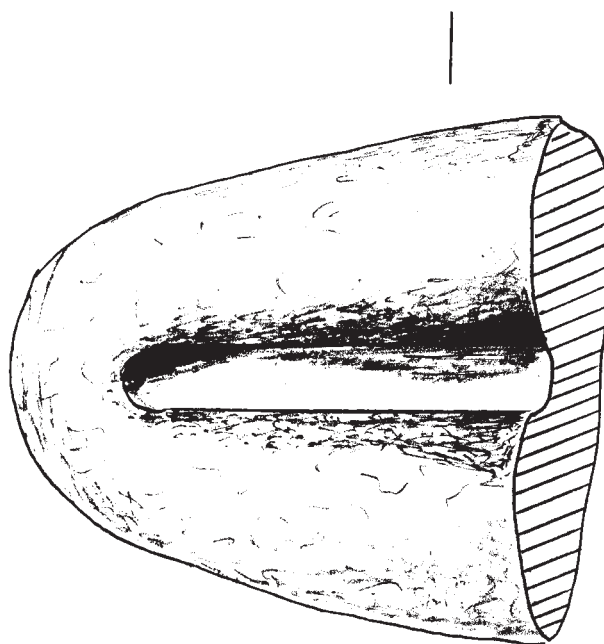
0 1cm

AREA VI, L0507

Fig. 11:2



No. 1 C-6025 [001]

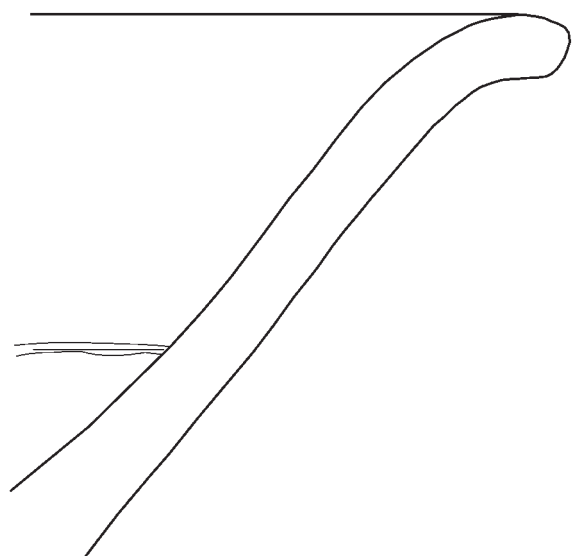


No. 4 F0926A

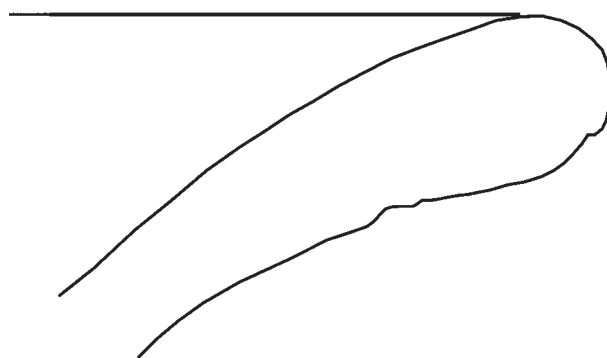
0 1cm

AREA VI, L0508

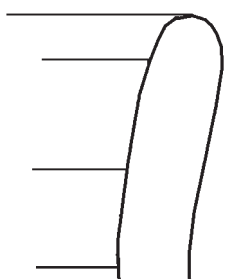
Fig. 12



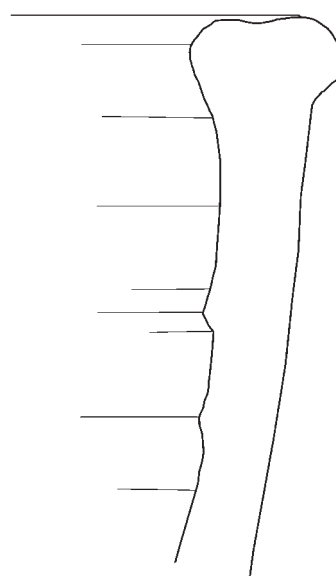
No. 1 C-6013 [004]



No. 2 C-6013 [006]



No. 3 C-6013 [007]

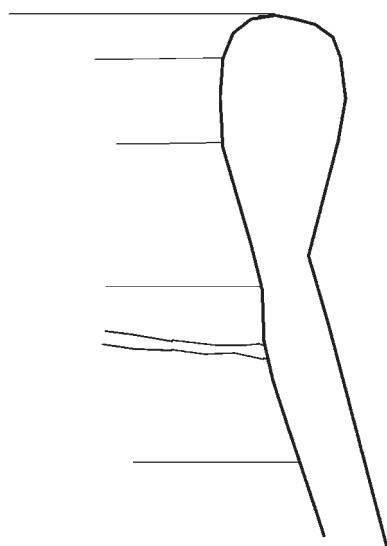


No. 4 C-6013 [010]

0 1cm

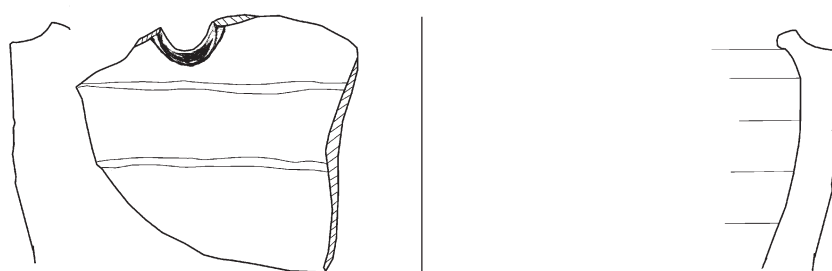
AREA VI, L0512

Fig. 13:1

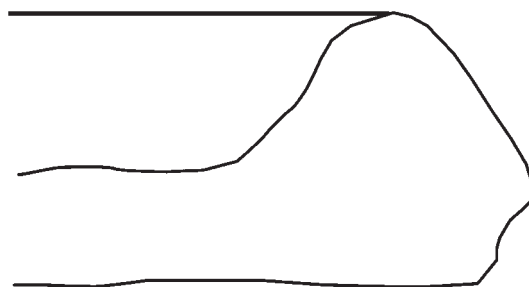


No. 5 C-6013 [009]

0 1cm

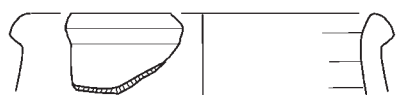


No. 9 C-6013 [001]



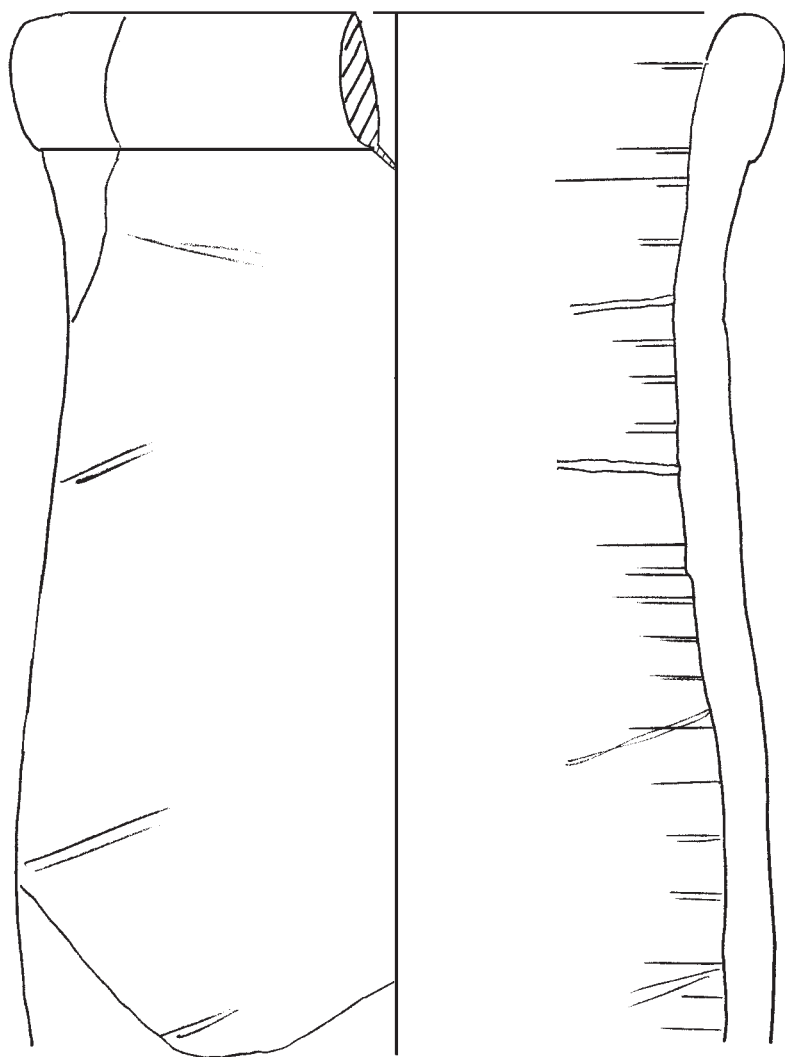
No. 10 C-6013 [014]

0 2cm



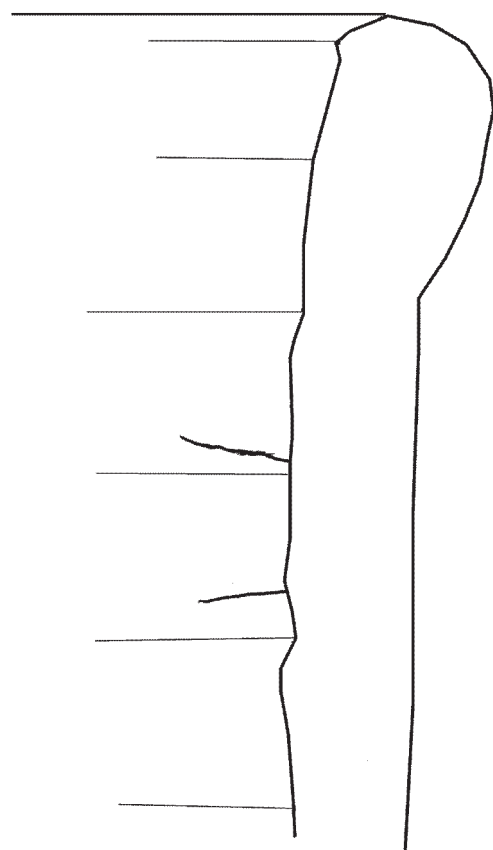
No. 2 P1259A

0 1cm

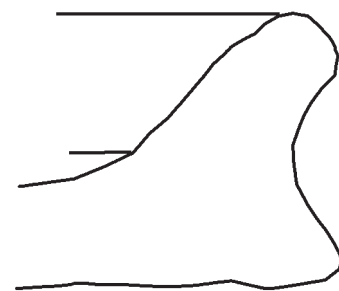


No. 3 P1160A

0 2cm



No. 4 C-6031 [003]

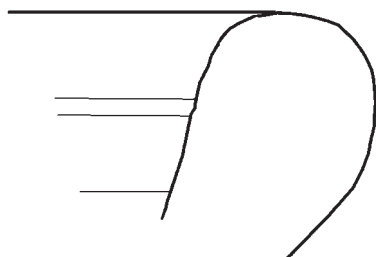


No. 5 C-6031 [002]

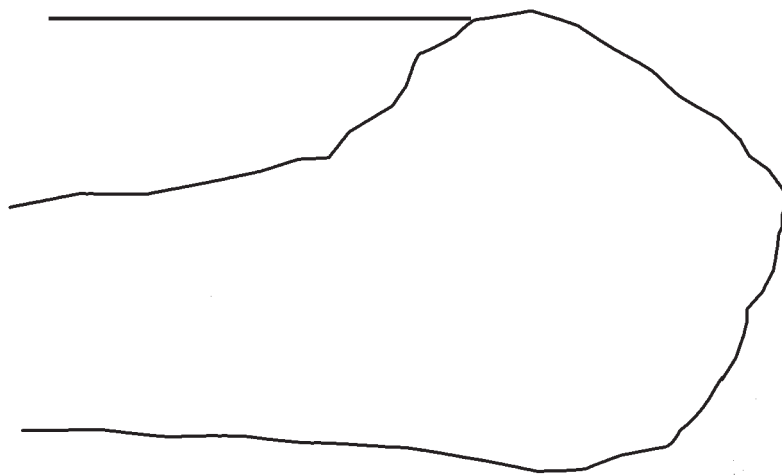
0 1cm

AREA VI, L0519

Fig. 14



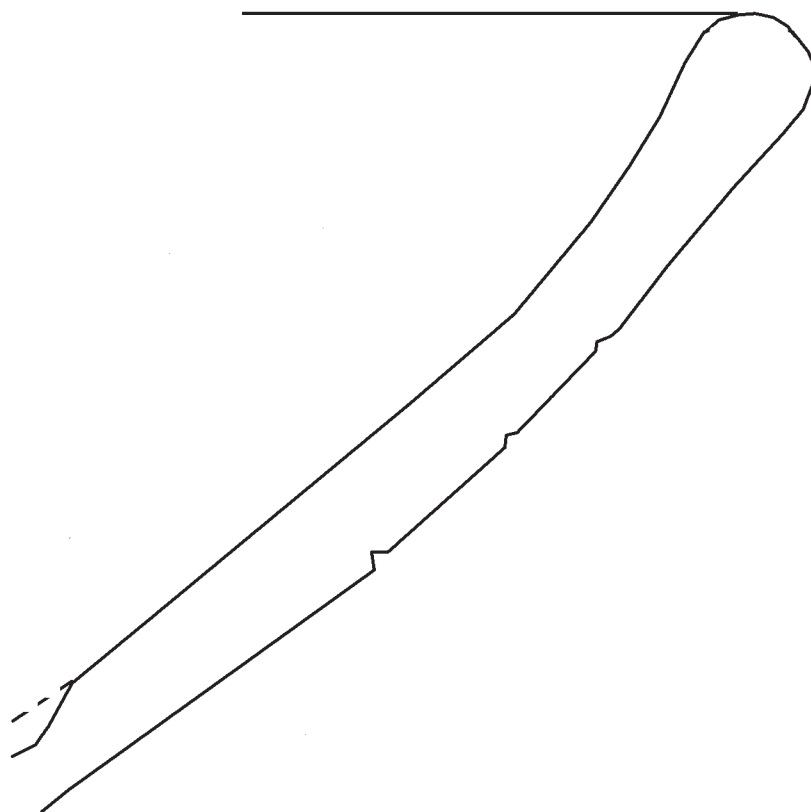
No. 2 C-6033 [002]



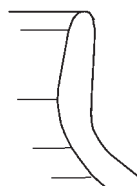
No. 3 C-6033 [001]

0 1cm

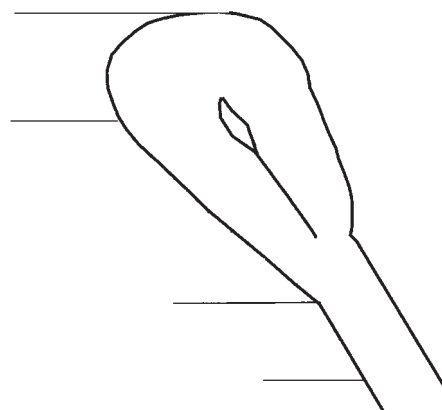
Fig. 15



No. 2 C-6012 [002]



No. 3 C-6012 [016]

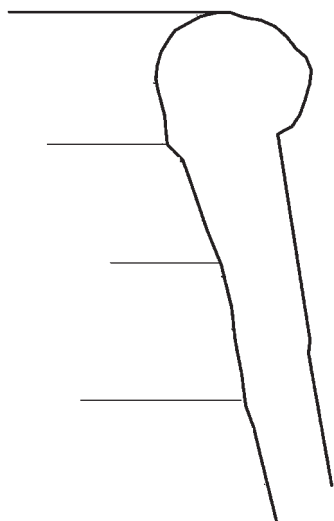


No. 5 C-6012 [010]

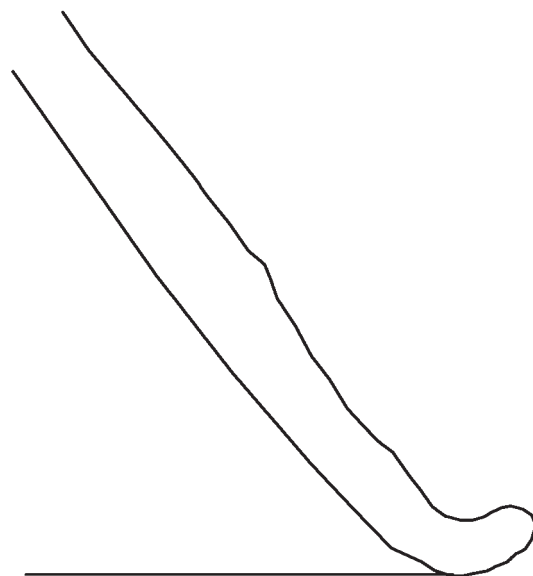
0 1cm

AREA VI, L0551

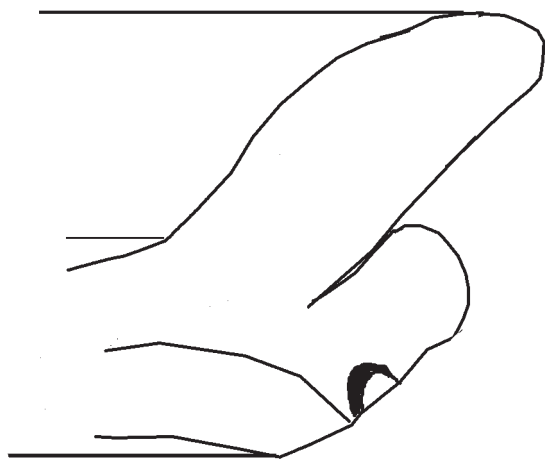
Fig. 16:1



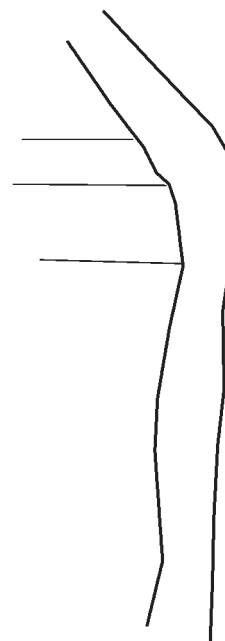
No. 6 C-6012 [009]



No. 10 C-6012 [005]



No. 11 C-6012 [003]

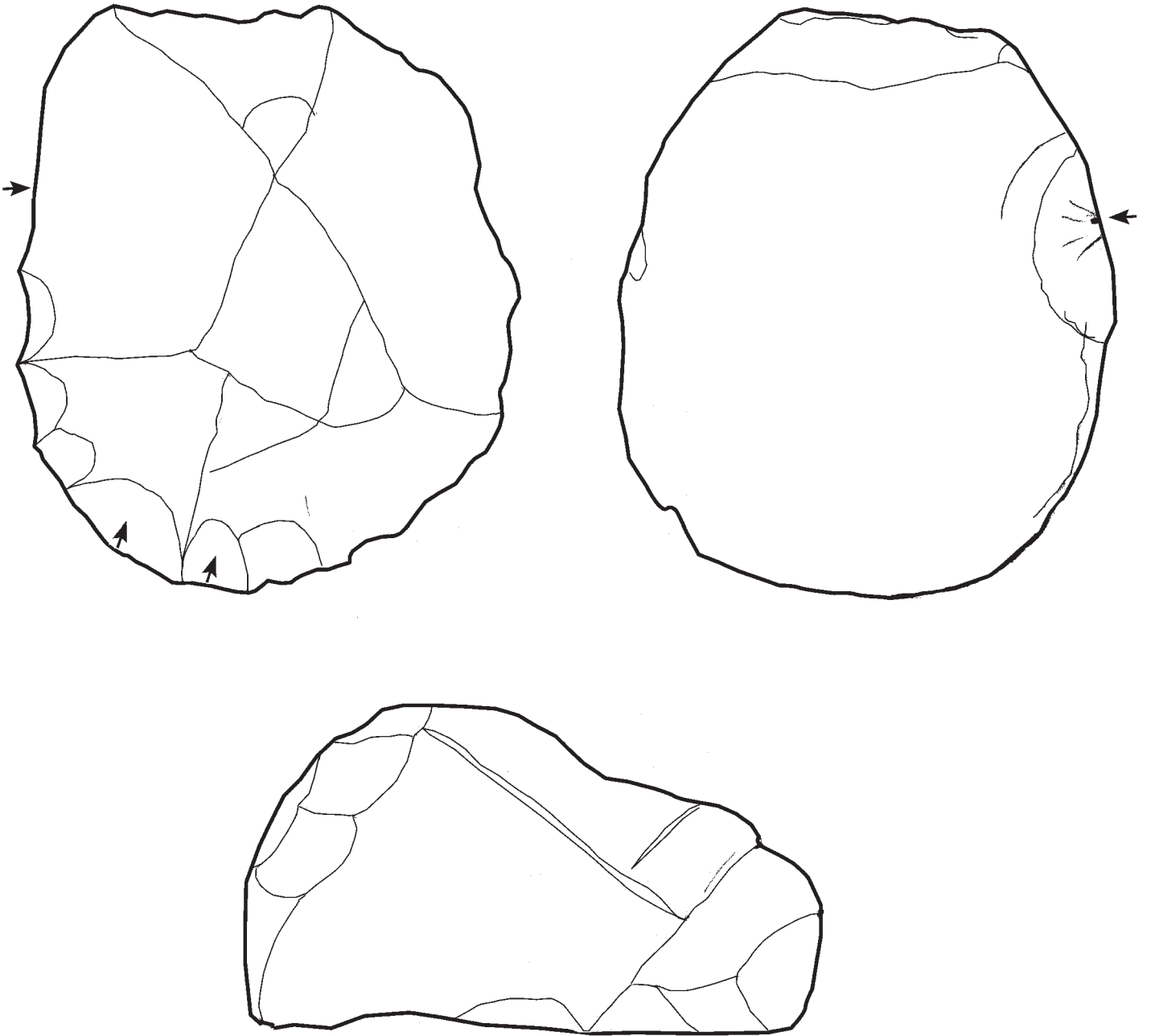


No. 17 C-6012 [017]

0 1cm

AREA VI, L0551

Fig. 16:2

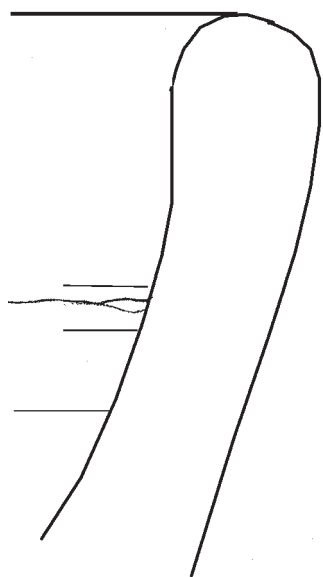


No. 21 F1102A

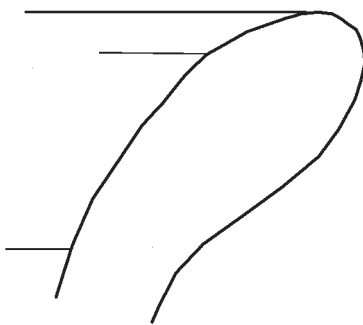
0 1cm

AREA VI, L0551

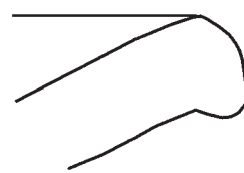
Fig. 16:3



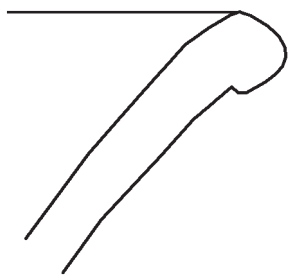
No. 1 C-6000 [020]



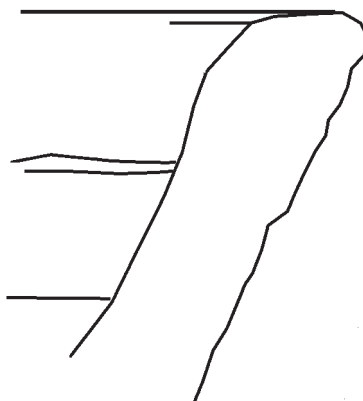
No. 2 C-6000 [044]



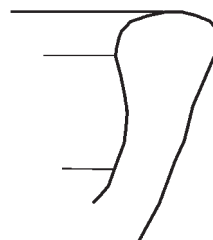
No. 3 C-6000 [028]



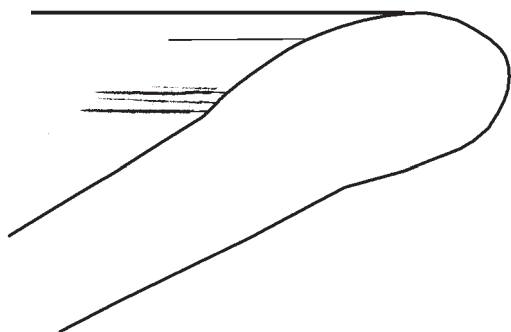
No. 4 C-6000 [046]



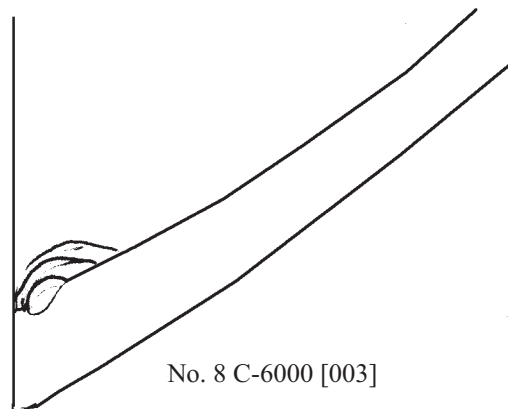
No. 5 C-6000 [022]



No. 7 C-6000 [029]



No. 6 C-6000 [018]

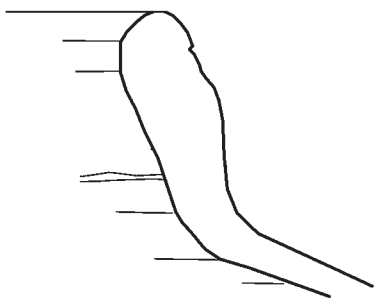


No. 8 C-6000 [003]

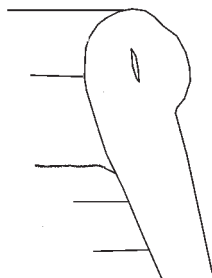
0 1cm

AREA VI, L1001

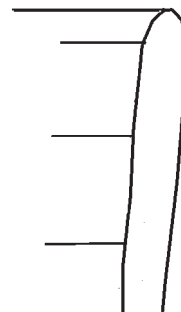
Fig. 17:1



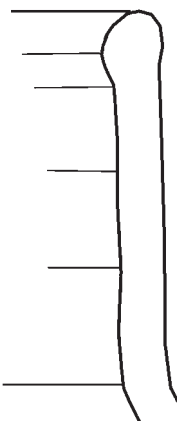
No. 9 C-6000 [047]



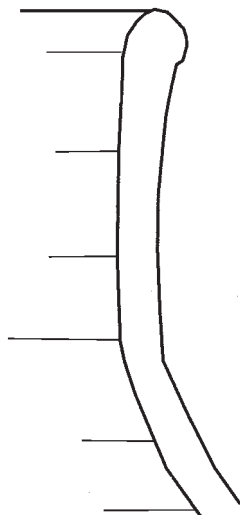
No. 10 C-6000 [048]



No. 11 C-6000 [012]



No. 12 C-6000 [014]



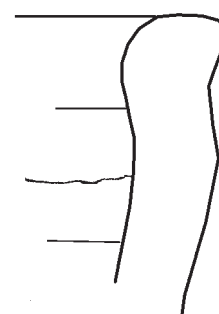
No. 13 C-6000 [011]



No. 14 C-6000 [051]



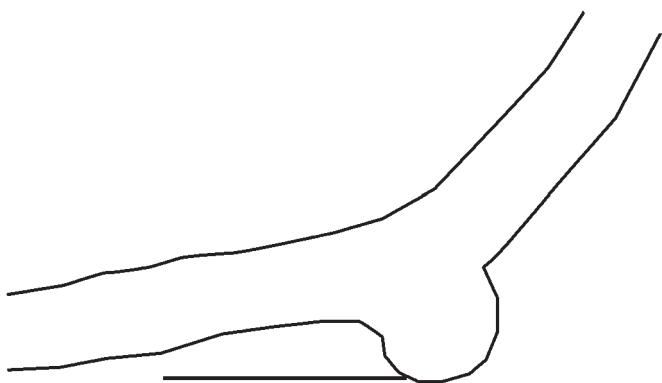
No. 15 C-6000 [013]



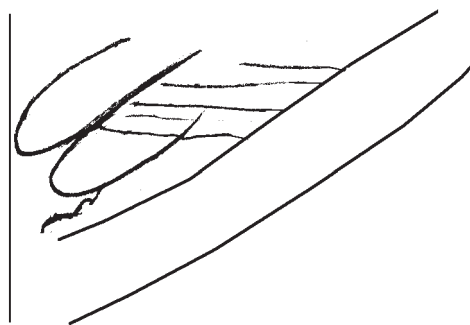
No. 16 C-6000 [010]

0 1cm

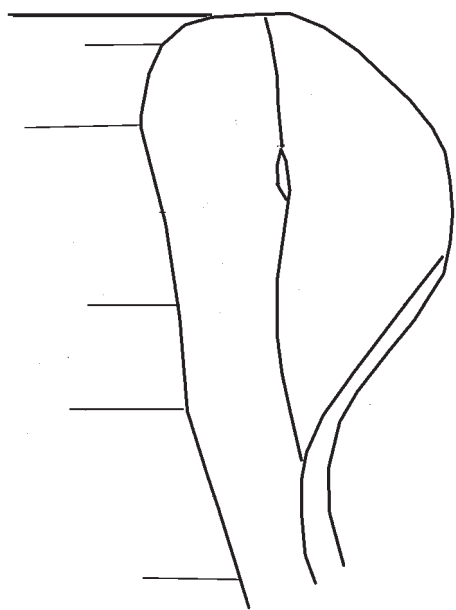
Fig. 17:2



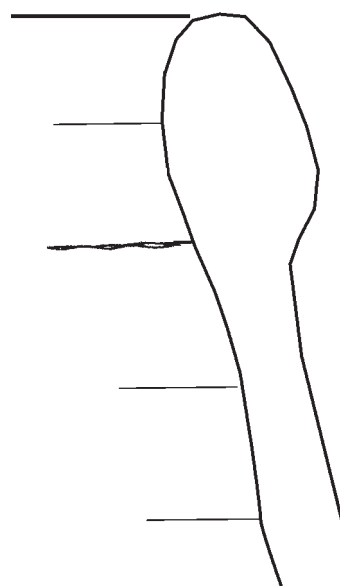
No. 17 C-6000 [001]



No. 18 C-6000 [004]



No. 19 C-6000 [036]

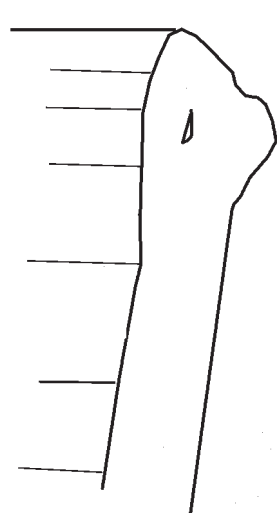


No. 20 C-6000 [037]

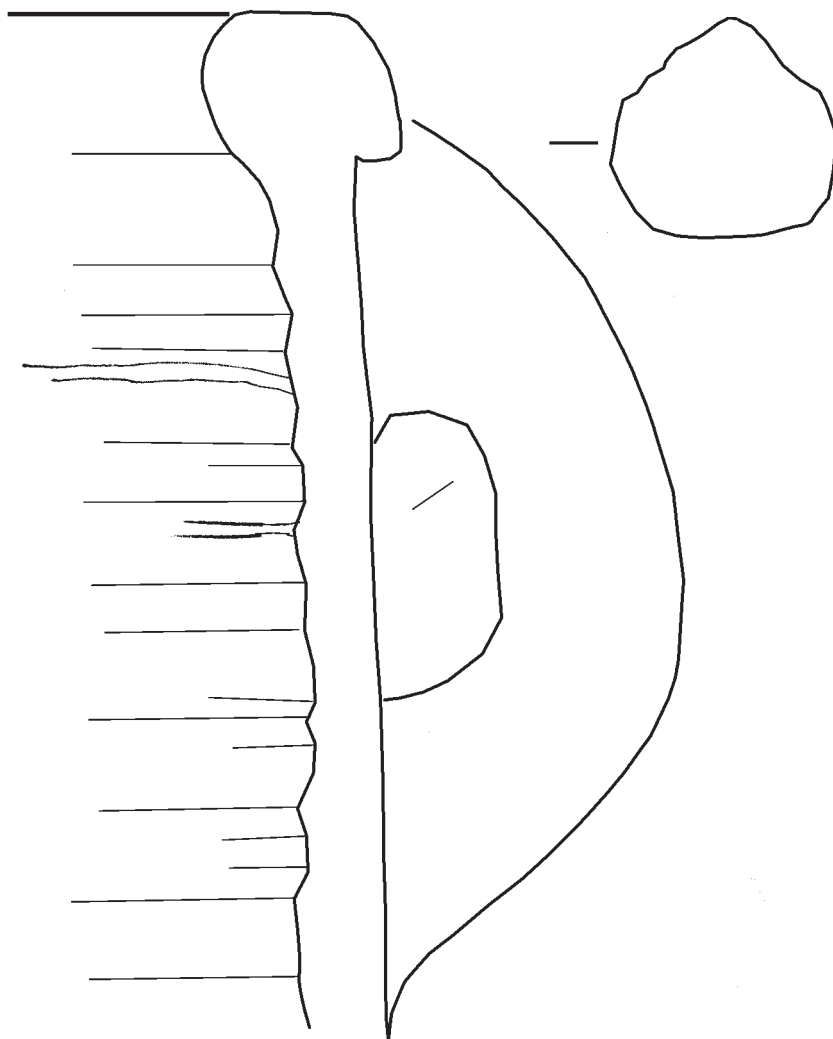
0 1cm

AREA VI, L1001

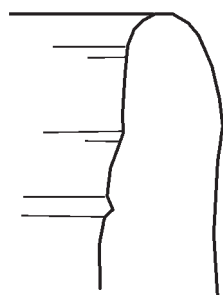
Fig. 17:3



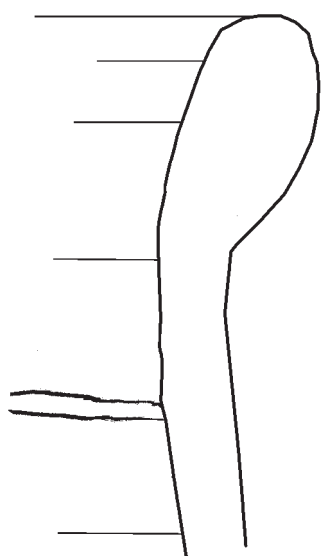
No. 21 C-6000 [030]



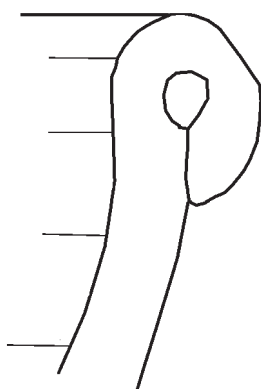
No. 22 C-6000 [032]



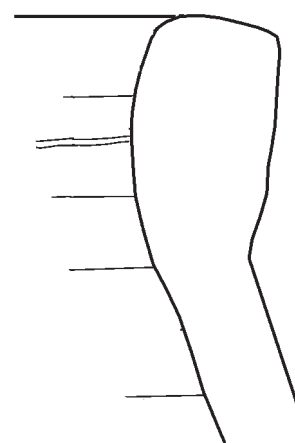
No. 23 C-6000 [052]



No. 24 C-6000 [034]



No. 25 C-6000 [031]

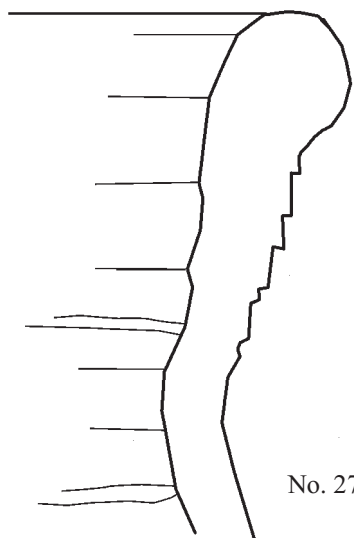


No. 26 C-6000 [040]

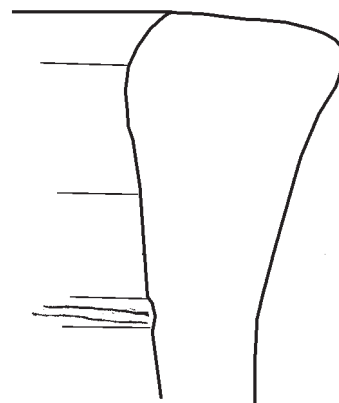
0 1cm

AREA VI, L1001

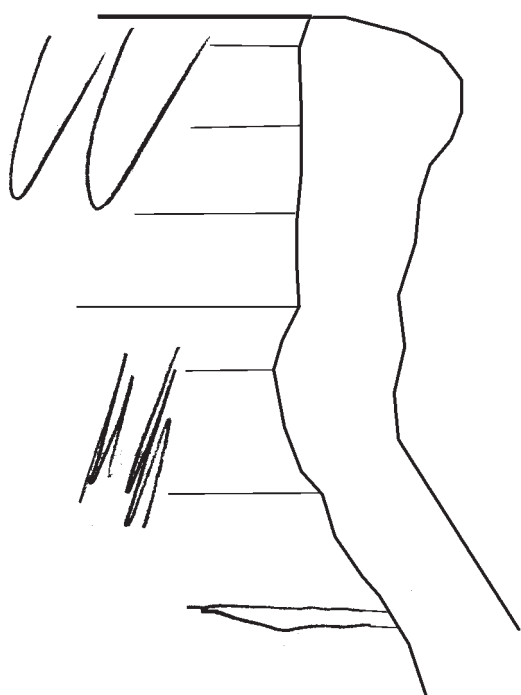
Fig. 17:4



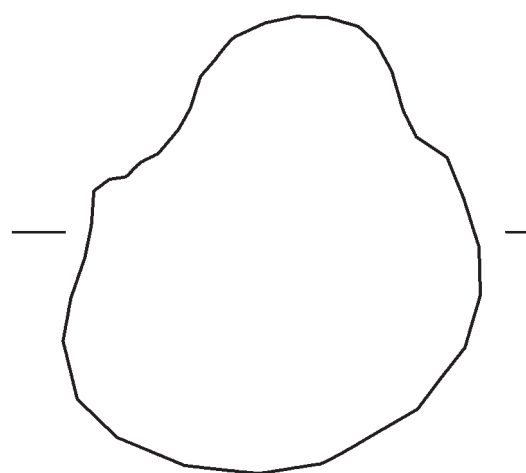
No. 27 C-6000 [008]



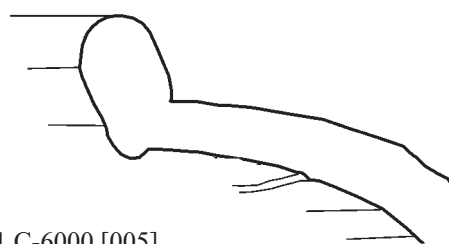
No. 28 C-6000 [017]



No. 29 C-6000 [007]

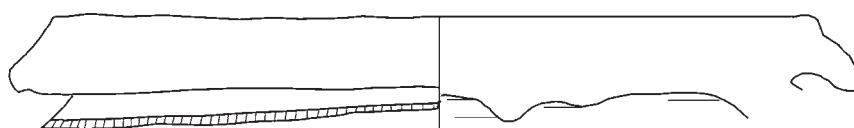


No. 30 C-6000 [039]



No. 31 C-6000 [005]

0 1cm

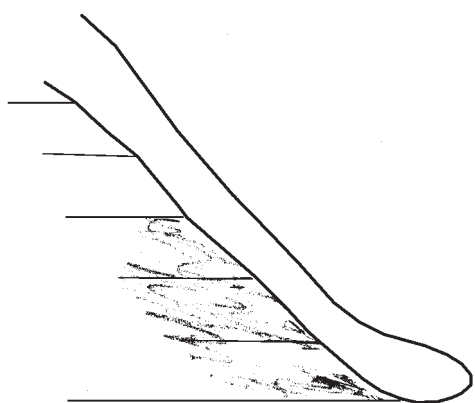


No. 32 P1114A

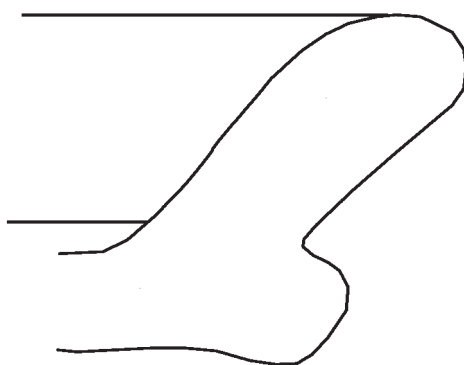
0 2cm

AREA VI, L1001

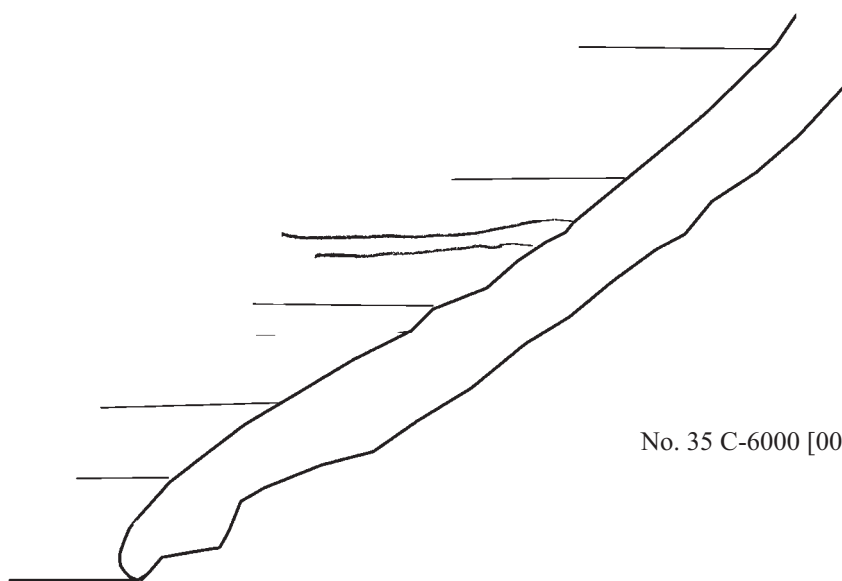
Fig. 17:5



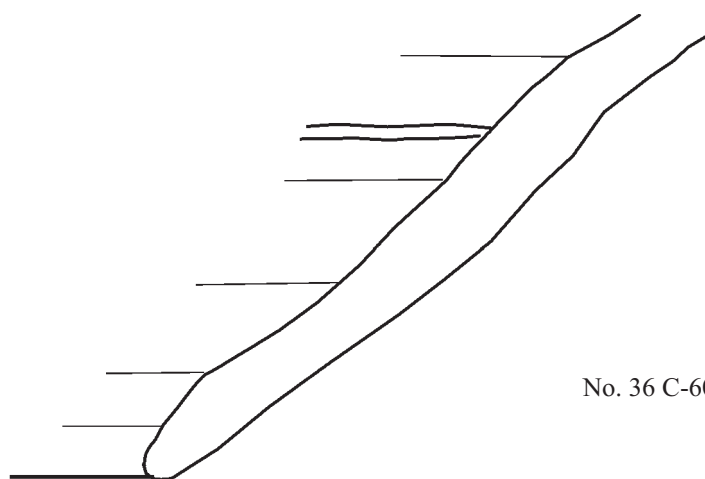
No. 33 C-6000 [006]



No. 34 C-6000 [027]



No. 35 C-6000 [009]

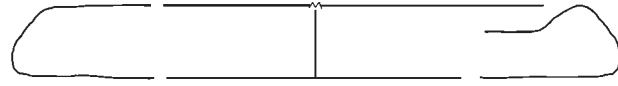


No. 36 C-6000 [016]

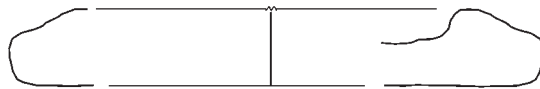
0 1cm

AREA VI, L1001

Fig. 17:6

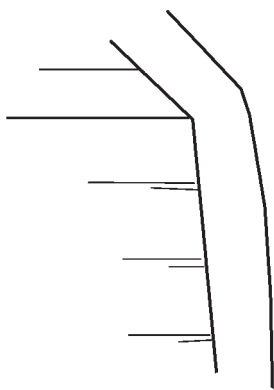


No. 37 P1119A

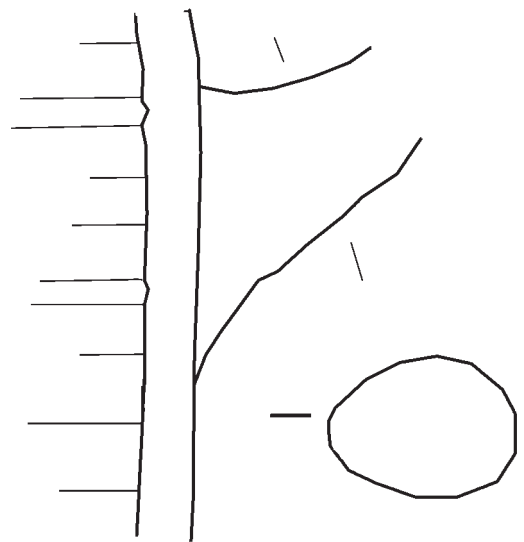


No. 38 P1118A

0 6cm



No. 41 C-6000 [003]

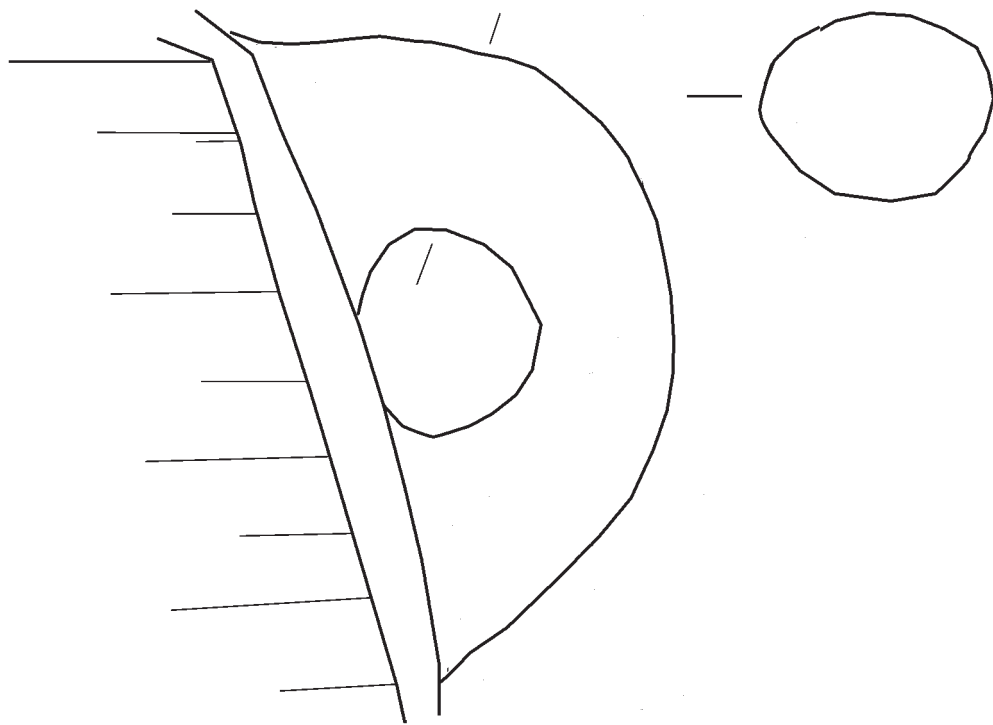


No. 45 C-6000 [054]

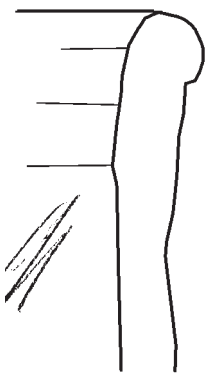
0 1cm

AREA VI, L1001

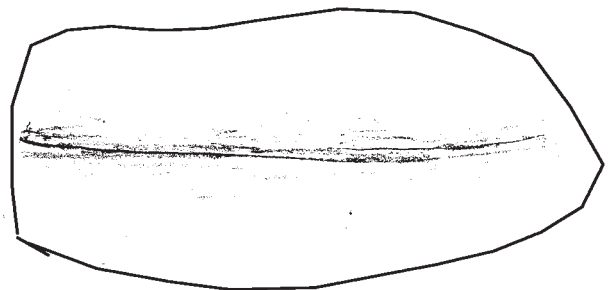
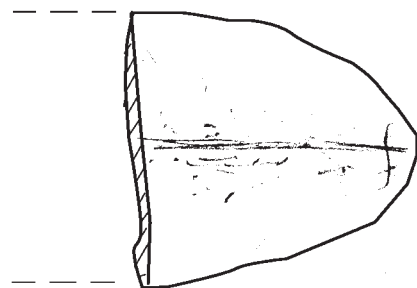
Fig. 17:7



No. 47 C-6000 [056]



No. 51 C-6000 [050]



No. 53 F1113A

0 1cm

AREA VI, L1001

Fig. 17:8